

DRIVELINE COMPONENTS CATALOG END YOKES

**J300P-4
SEPTEMBER 2008**

**Supersedes
Section 4, Dated
February 2005**



Changes from original:

10/16/08 Page 33 6-4-4151 & 6-4-4151-1 - counterbore depth of .250

3/20/09 Page 58 - corrected drawing and enhanced heading for "P"

11/23/10 corrected centerline to hub end for 140-4-331-1X

11/23/10 corrected column spacing on pages 60-61

INCLUDED IN THIS CATALOG

This publication represents the most comprehensive listing of Spicer® splined hole end yokes ever published by Dana. We have included all the part numbers currently being produced. We have also included and noted parts that are now discontinued, parts that will be available until current stock is exhausted, as well as parts that have been superseded. Most current stock will be in inventory at our distribution centers, and any numbers not inventoried can be supplied upon request.

- Spicer Life® Series yokes begin on page 2.
- Listings for round, hex, square, tapered hole and steering shaft yokes are listed in this catalog beginning on page 54.
- A chart showing the configuration and dimensions of all slingers used on end yoke Assemblies begins on page 63.
- Listings have been expanded to assist in the identification of parts, and to help find the correct part or an alternate part for the application.
- All styles of end yokes (bearing plate (BP), bearing strap (BS), cap and bolt (CB), constant velocity (CV), half round (HR), snap ring (SR), inside snap ring (ISR), u-bolt (UB), and winged bearing (WB)) are listed under their corresponding series/spline header, allowing easy substitution of one type for another.
- All of the listings are sorted so that all the individual styles of end yokes, along with the many different seal (hub) diameters and lengths are readily accessible. With this sorting method, alternate style substitutions (u-bolt for bearing strap) or acceptable hub diameter substitutions can be made by looking on only one page of the catalog.
- All footnotes except those regarding part status are listed immediately under the yoke dimensional data, alleviating the need to look at the bottom of the page.

IMPORTANT NOTICE: The data listed herein is correct to the best of our knowledge and belief; having been compiled from reliable and official sources of information. However, WE CANNOT ASSUME ANY RESPONSIBILITY for possible error.



HOW TO USE THIS CATALOG

To identify any end yoke, there are two pieces of required information:

1. Series (Measurements to determine series can be found in each series header.)
2. Center Hole Type and Size

Center hole type is described at the top center of each page, and series designations are listed in ascending order by center hole type. After determining series and center hole size, and turning to the appropriate page, all sizes of center holes will be listed under the series designation, along with the different types of end yokes (snap ring (SR), u-bolt (UB), bearing strap (BS), etc.).

Example: To find a 1310 Series Yoke with a 1.146-26 Involute splined hole (see sample page below)

- ① Find the 1310 Series heading
- ② Find the 1.0700-16 Involute Spline sub-heading
- ③ Find a 1.5520 Ground Hub Diameter dimension
- ④ Find a 1.5000 Length Through Hole dimension
- ⑤ Find a 3.0000 Centerline to End dimension
- ⑥ Find a Bearing Strap Style — BS
- ⑦ Locate the part number. Assemblies include slingers, order when available.

① Major Diameter	R	Q	S	C'Bore Depth	Style	End Yoke Assy. (includes slinger) Order When Listed	Slinger Part Number	Spicer Part Number
	Ground Hub Dia.	Length Thru Hole	Centerline to End					
1310 SERIES (Continued) SR: E-3.469 OTHERS E-3.219, D-1.062 USE KIT 5-153X,5-785X,5-810X								
USES U-BOLT ASSY. 2-94-28X, STRAP ASSY. 2-70-18X								
1.1460-26 Involute Spline								
② 1.1460	1.5130	2.0000	3.3000	—	SR	2-4-8171X	232184	2-4-8161 <i>Coupling shaft yoke</i>
1.1460	③ 1.5520	④ 1.5000	⑤ 3.0000	—	UB	2-4-8091X	41498	2-4-8081
1.1460	1.5520	1.5000	3.0000	—	⑥ BS	⑦ 2-4-8091-1X	41498	2-4-8081-1
1.1460	③ 1.8440	④ 1.3700	⑤ 3.1300	.1200	BS	2-4-8551-1X	232816	2-4-8521-1

Note the following information from the sample above:

2-4-8091-1X (BS style) could easily be substituted for 2-4-8091X (UB style) by using bearing strap assembly 2-70-18X.

• Part is discontinued ■ Part is available until supply is exhausted ▲ Not sold separately



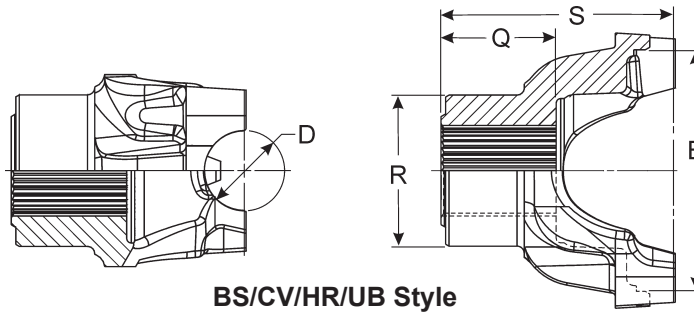

BS/CV/HR/UB Style

Major Diameter	R	Q	S	C'Bore Depth	Style	End Yoke Assy. (includes slinger/plug) Order When Listed	Slinger/Plug Part Number	Spicer Part Number
	Ground Hub Dia.	Length Thru Hole	Centerline to End					
SPL55 SERIES			E-4.188, D-1.375		USE KIT SPL55-1X, SPL55-2X, 5-803X, 5-804X			
USE STRAP ASSY 3-70-38X								
1.567-36 Involute Spline								
1.567	2.618	1.980	4.025	—	BS			55-4-11-1 <i>Coupling shaft yoke</i>
1.790-34 Involute Spline								
1.790	2.375	2.188	4.219	—	BS	55-4-41-1X	233034	55-4-31-1 ▲
1.790	2.564	2.760	4.870	—	BS	55-4-131-1X•	231059	55-4-121-1 ▲ <i>For 9" x 3" Brake</i>
1.790	2.564	2.760	4.870	—	BS	5001480	231059	55-4-201-1 ▲
1.790	2.564	2.760	4.870	—	BS	55-4-101-1X•	231059	55-4-91-1 ▲ <i>For 9" x 3" Brake</i>
2.024-39 Involute Spline								
2.024	3.000	2.281	4.330	.250	BS	55-4-81-1X•	232511	55-4-71-1 ▲
SPL70 SERIES			E-4.964, D-1.375		USE KIT SPL70X, SPL70-1X, 5-808X, 5-809X			
USE STRAP ASSY. 3-70-38X								
1.543-24 Involute Spline								
1.543	2.241	1.844	5.750	—	BS	70-4-271-1X•	—	70-4-261-1 ▲ <i>Flanged yoke w/weight, 7-73-620 bolts</i>
1.750-10 Spline								
1.750	2.500	2.000	5.750	—	BS	70-4-171-1X•	—	70-4-161-1 ▲ <i>Flanged yoke w/weight, 7-73-620 bolts</i>
1.783-34 Involute Spline								
1.783	2.940	2.236	4.244	—	BS			70-4-11-1 <i>Coupling shaft yoke</i>
1.790-34 Involute Spline								
1.790	2.375	2.188	4.000	—	BS	70-4-61-1X	233034	70-4-51-1 ▲
1.790	2.562	2.750	6.650	—	BS	5001789	231059	5001781• <i>Flanged yoke w/four holes in flange</i>
1.790	2.564	2.750	5.530	—	BS	70-4-191-1X•	231059	70-4-181-1 ▲ <i>Flanged yoke w/weight, 7-73-620 bolts;</i>
2.024-39 Involute Spline								
2.024	3.000	1.844	3.878	.250	BS	5006977	5006975	5001782 ▲
2.024	3.000	1.847	3.893	.250	BS	5003330	5006975	5003329 ▲
2.024	3.000	2.281	4.281	.250	BS	70-4-111-1X	232511	70-4-101-1 ▲
2.143-41 Involute Spline								
2.143	2.938	2.500	4.555	—	BS	70-4-151-1X	232604	70-4-141-1 ▲

• Part is discontinued

■ Part is available until supply is exhausted

▲ Not sold separately



END YOKES with SPLINED HOLES

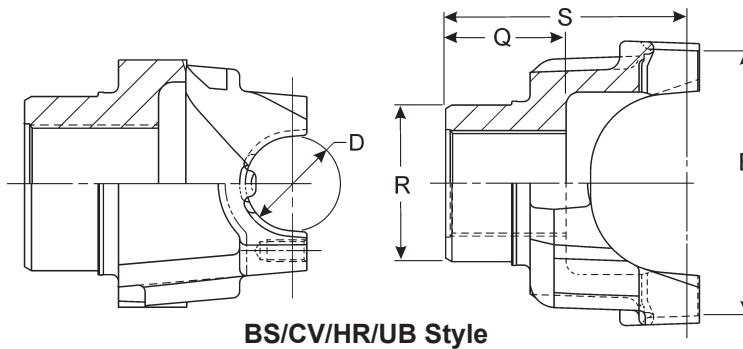

BS/CV/HR/UB Style

Major Diameter	R	Q	S	C'Bore Depth	Style	End Yoke Assy. (includes slinger) Order When Listed	Slinger/Plug Part Number	Spicer Part Number
	Ground Hub Dia.	Length Thru Hole	Centerline to End					
SPL90 SERIES			E-4.957, D-1.625			USE KIT SPL100-1X		
USE STRAP ASSY. 90-70-28X								
1.750-10 Spline								
1.750	2.500	1.938	4.125	—	BS			90-4-371-1
1.774-34 Involute Spline								
1.774	2.500	2.250	4.110	—	BS	90-4-761-1X	231206	90-4-751-1•
1.790-34 Involute Spline								
1.790	2.375	2.188	5.625	—	BS	90-4-551-1X	232198	90-4-541-1•
1.790	2.500	2.250	4.062	—	BS			90-4-11-1 <i>Coupling shaft yoke</i>
1.790	2.562	2.750	5.609	—	BS	90-4-191-1X	231059	90-4-181-1•
1.790	2.562	2.750	5.625	—	BS	90-4-501-1X	231059	90-4-461-1▲
1.962-10 Spline								
1.962	2.625	2.250	5.094	—	BS	90-4-211-1X•	230909	90-4-201-1▲
1.962	2.750	2.781	4.984	—	BS			90-4-381-1
1.998-38 Involute Spline								
1.998	2.750	2.125	4.000	—	BS			90-4-71-1
1.998	2.750	2.125	4.250	—	BS			90-4-391-1
1.998	2.750	2.125	7.562	—	BS			90-4-111-1 <i>Flanged end yoke.</i>
1.998	3.000	2.125	4.250	—	BS	90-4-571-1X	232200	90-4-561-1•
2.000-10 Spline								
2.000	2.750	3.000	4.969	—	BS			90-4-21-1
2.024-39 Spline								
2.024	3.000	2.312	4.625	—	BS	90-4-321-1X	231359	90-4-311-1
2.024-39 Involute Spline								
2.024	2.626	2.245	4.160	—	BS	90-4-631-1X	232039	90-4-621-1▲
2.024	3.000	2.281	4.750	.250	BS	90-4-251-1X	232511	90-4-241-1
2.114-32 Involute Spline								
2.114	3.000	2.250	4.375	.424	BS	90-4-591-1X	232200	90-4-581-1•
2.141-41 Involute Spline								
2.141	2.938	2.500	4.562	—	BS	90-4-691-1X	232604	90-4-471-1▲
<i>90-4-691-1X was replaced by 100-4-1061-1X</i>								
2.178-41 Involute Spline								
2.178	3.543	1.882	4.570	—	BS	5001046	5001045	5001036▲
2.178-43 Involute Spline								
2.178	3.547	2.031	4.625	.157	BS			90-4-791-1
2.250-10 Spline								
2.250	3.750	3.000	5.219	—	BS	90-4-171-1X•	231616	90-4-161-1•
2.281-44 Involute Spline								
2.281	2.938	2.344	4.469	—	BS	100-4-1381-1X	232604	90-4-281-1•

• Part is discontinued ■ Part is available until supply is exhausted ▲ Not sold separately



Important: See Safety Information in General Information Section (J300P-GI)

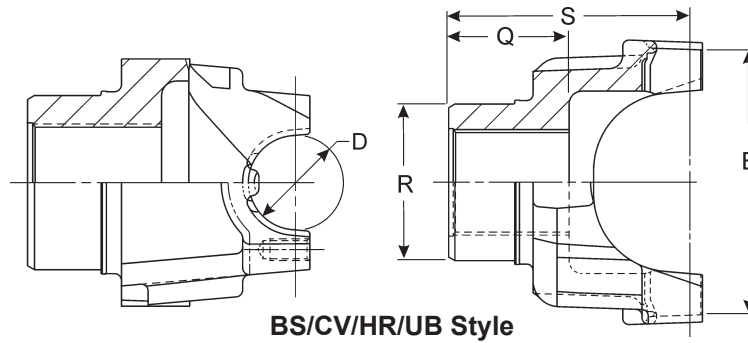

Major Diameter	R	Q	S	C'Bore Depth	Style	End Yoke Assy. (includes slinger/plug) Order When Listed	Slinger/Plug Part Number	Spicer Part Number
	Ground Hub Dia.	Length Thru Hole	Centerline to End					
SPL90 SERIES (Continued) E-4.957, D-1.625						USE KIT SPL100-1X		
USE STRAP ASSY. 90-70-28X								
2.364-36 Involute Spline								
2.364	3.000	2.688	4.812	—	BS	90-4-611-1X	232200	90-4-601-1•
2.374-46 Involute Spline								
2.374	3.250	2.875	5.188	—	BS	90-4-361-1X•	231615	90-4-351-1•
2.390-46 Involute Spline								
2.390	3.250	2.312	4.641	—	BS	90-4-341-1X	231803	90-4-331-1•
2.390-47 Involute Spline								
2.390	3.344	1.781	4.250	—	BS	90-4-531-1X	232195	90-4-521-1▲
SPL100 SERIES E-4.958 D-1.626						USE KIT SPL100-1X		
USE BEARING RETAINER NO. 90-70-28X								
1.771-34 Involute Spline								
1.771	2.750	2.230	4.060	—	BS			100-4-931-1 <i>Coupling shaft yoke</i>
1.790-34 Involute Spline								
1.790	2.562	2.750	5.700	—	BS	100-4-901-1X	231059	100-4-891-1▲ <i>Flanged end yoke.</i>
1.790	2.562	2.755	5.630	—	BS	100-4-1021-1X	231059	100-4-1011-1▲
2.024-39 Involute Spline								
2.024	2.625	2.245	4.160	—	BS	100-4-1081-1X	232167	100-4-1071-1▲
2.024	2.625	2.245	7.295	—	BS	100-4-1331-1X	232039	100-4-1321-1▲
<i>Flanged yoke w/8 tapped holes in flange</i>								
2.024	3.000	1.817	4.150	.250	BS	5006608	5006975	5006607▲
2.024	3.000	2.269	7.295	—	BS	100-4-1371-1X	232511	100-4-1361-1▲ <i>Flanged end yoke</i>
2.024	3.000	2.284	4.750	—	BS	100-4-961-1X•	232511	100-4-951-1▲
2.143-41 Involute Spline								
2.143	3.000	2.166	4.310	.310	BS	5002875	5002871	5002874▲
2.173-26 Involute Spline								
2.173	3.069	1.812	4.330	.197	BS	5003087	5003086	5001694▲
2.195-34 Involute Spline								
2.950	3.543	1.889	3.823	—	BS			5007598▲ <i>OEM only</i>
SPL140 SERIES E-5.457 IN. D-1.938 IN.						USE KIT SPL140X		
USE BEARING RETAINER NO. 140-70-18X								
1.774-34 Spline								
1.774	2.500	2.500	4.950	—	HR	140-4-261-1X	231101	140-4-251-1▲
1.962-10 Spline								
1.962	2.750	2.805	5.810	—	HR			140-4-181-1•
1.998-38 Involute Spline								
1.998	2.750	2.125	4.730	—	HR			140-4-891-1
1.998	2.750	2.125	4.830	—	HR			140-4-111-1

• Part is discontinued

■ Part is available until supply is exhausted

▲ Not sold separately



Major Diameter	R	Q	S	C'Bore Depth	Style	End Yoke Assy. (includes slinger/plug) Order When Listed	Slinger/Plug Part Number	Spicer Part Number
	Ground Hub Dia.	Length Thru Hole	Centerline to End					
SPL140 SERIES (Continued) E-5.457 IN. D-1.938 IN.						USE KIT SPL140X		
USE BEARING RETAINER NO. 140-70-18X								
1.998-38 Involute Spline (Continued)								
1.998	2.750	2.125	4.830	—	HR			140-4-1131-1•
1.998	2.750	2.125	7.728	—	HR			140-4-1021-1• <i>Flanged end yoke.</i>
1.998	2.810	2.745	5.370	—	HR			140-4-11-1 <i>Coupling shaft yoke</i>
1.998	3.000	2.125	4.680	—	HR	140-4-911-1X•	232200	140-4-901-1▲
2.024-39 Spline								
2.024	2.750	2.435	5.250	.090	HR	140-4-1431-1X•	231599	140-4-1421-1•
2.024	3.000	2.312	5.680	.090	HR	140-4-231-1X	231359	140-4-211-1▲
2.024	3.000	2.312	5.680	.090	HR	140-4-241-1X	232182	140-4-211-1▲
2.024-39 Involute Spline								
2.024	3.000	2.284	4.940	—	HR	140-4-1161-1X•	232511	140-4-1151-1▲
2.024	3.000	2.284	4.940	.250	HR	140-4-371-1X	232511	140-4-361-1•
2.024	3.000	2.284	7.587	.250	HR	140-4-1401-1X	232511	140-4-1391-1▲ <i>Metric flanged yoke</i>
2.114-32 Involute Spline								
2.114	3.000	2.250	4.810	.424	HR	140-4-931-1X•	232200	140-4-921-1▲
2.143-41 Involute Spline								
2.143	2.938	2.500	5.560	—	HR	140-4-431-1X	232604	140-4-421-1▲
2.178-43 Involute Spline								
2.178	3.539	2.050	5.100	.157	HR			140-4-761-1•
2.178	3.541	2.047	5.100	.160	HR			140-4-1231-1•
2.195-34 Involute Spline								
2.195	3.543	1.889	4.421	—	HR			5007599▲ <i>OEM only</i>
2.195	3.543	1.889	4.646	—	HR			5007600▲ <i>OEM only</i>
2.250-10 Spline								
2.250	3.500	3.000	6.000	—	HR	140-4-1101-1X•	231616	140-4-1091-1▲
2.274-44 Spline								
2.274	3.000	2.500	5.160	.236	HR	140-4-331-1X	232511	140-4-321-1▲ <i>Metric flanged yoke</i>
2.274-44 Involute Spline								
2.274	2.938	2.344	5.190	—	HR	140-4-1201-1X•	232604	140-4-1191-1▲
2.274	2.938	2.350	5.190	—	HR	140-4-451-1X	232604	140-4-441-1▲
2.274	3.000	2.500	5.160	.236	HR	140-4-1271-1X•	232511	140-4-1261-1▲
2.374-46 Spline								
2.374	3.250	2.875	6.210	.140	HR	140-4-291-1X	231615	140-4-271-1▲
2.390-46 Involute Spline								
2.390	2.375	3.195	6.440	.580	HR	140-4-391-1X	232610	140-4-381-1▲
2.390	3.250	2.323	5.660	.140	HR	5003557	5003552	140-4-301-1▲
2.390	3.250	2.323	5.660	.140	HR	140-4-311-1X	231803	140-4-301-1▲
2.390	3.312	2.750	5.374	.157	HR			140-4-1011-1
2.390	3.500	3.375	5.920	—	HR			140-4-751-1
2.500-10 Spline								
2.500	3.750	3.000	5.960	—	HR	140-4-1121-1X	231616	140-4-1111-1▲
2.500	3.750	3.000	5.960	—	HR	140-4-51-1X	231616	140-4-41-1•
2.544-49 Involute Spline								
2.544	3.750	3.000	5.570	—	HR	140-4-151-1X•	231616	140-4-141-1▲
2.544	4.000	2.750	6.060	.180	HR			140-4-881-1
2.750-10 Spline								
2.750	3.750	3.000	6.570	—	HR	140-4-71-1X	230902	140-4-61-1▲

• Part is discontinued ■ Part is available until supply is exhausted ▲ Not sold separately



Important: See Safety Information in General Information Section (J300P-GI)

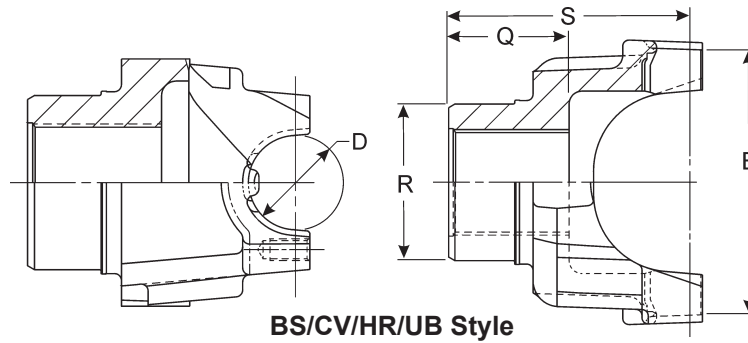

Major Diameter	R	Q	S	C'Bore Depth	Style	End Yoke Assy. (includes slinger/plug) Order When Listed	Slinger/Plug Part Number	Spicer Part Number
	Ground Hub Dia.	Length Thru Hole	Centerline to End					

SPL140 SERIES (Continued) E-5.457 IN. D-1.938 IN. USE KIT SPL140X

USE BEARING RETAINER NO. 140-70-18X

2.750-10 Spline (Continued)

2.750	3.750	3.000	6.570	—	HR	140-4-91-1X	231616	140-4-81-1 ▲
-------	-------	-------	-------	---	----	-------------	--------	--------------

2.794-54 Involute Spline

2.794	—	2.745	6.320	—	HR			140-4-201-1
-------	---	-------	-------	---	----	--	--	-------------

2.795-55 Involute Spline

2.795	4.725	2.047	4.980	.150	HR			140-4-771-1
-------	-------	-------	-------	------	----	--	--	-------------

SPL170 SERIES E-6.456 IN. D-2.166 IN. USE KIT SPL170-3X

USE BEARING RETAINER KIT NO. 170-70-18X

1.774-34 Spline

1.774	2.500	2.250	6.440	.090	HR	5009705	231101	170-4-631-1• High angle yoke
-------	-------	-------	-------	------	----	---------	--------	---------------------------------

1.790-34 Involute Spline

1.790	2.500	2.250	5.030	.090	HR			170-4-921-1
-------	-------	-------	-------	------	----	--	--	-------------

1.790	2.625	2.438	5.600	.250	HR	170-4-121-1X	232166	170-4-111-1•
-------	-------	-------	-------	------	----	--------------	--------	--------------

1.790	2.625	2.438	6.250	.250	HR	170-4-141-1X	232166	170-4-131-1 ▲ High angle yoke
-------	-------	-------	-------	------	----	--------------	--------	----------------------------------

1.989-30 Involute Spline

1.989	3.000	2.685	6.580	.220	HR			170-4-771-1 High angle yoke
-------	-------	-------	-------	------	----	--	--	--------------------------------

1.998-38 Involute Spline

1.998	2.750	2.125	4.844	—	HR			170-4-541-1
-------	-------	-------	-------	---	----	--	--	-------------

2.024-39 Spline

2.024	2.750	2.000	5.370	.120	HR	170-4-1261-1X	232042-2	170-4-1251-1 High angle yoke
-------	-------	-------	-------	------	----	---------------	----------	---------------------------------

2.024	3.000	2.312	5.090	.105	HR	170-4-651-1X	231359	170-4-641-1
-------	-------	-------	-------	------	----	--------------	--------	-------------

2.024	3.000	2.312	5.090	.105	HR	170-4-701-1X•	232182	170-4-641-1
-------	-------	-------	-------	------	----	---------------	--------	-------------

2.024	3.000	2.312	5.090	.105	HR	170-4-681-1X•	231102	170-4-641-1
-------	-------	-------	-------	------	----	---------------	--------	-------------

2.024	3.000	2.312	6.391	.105	HR	170-4-691-1X	232182	170-4-661-1• High angle yoke
-------	-------	-------	-------	------	----	--------------	--------	---------------------------------

2.024	3.000	2.312	6.391	.105	HR	170-4-671-1X	231359	170-4-661-1• High angle yoke
-------	-------	-------	-------	------	----	--------------	--------	---------------------------------

2.024-39 Involute Spline

2.024	2.625	2.250	4.938	.250	HR	170-4-161-1X■	232167	170-4-151-1 ▲
-------	-------	-------	-------	------	----	---------------	--------	---------------

2.024	2.625	2.250	6.016	.250	HR	170-4-181-1X■	232167	170-4-171-1 ▲ High angle yoke
-------	-------	-------	-------	------	----	---------------	--------	----------------------------------

2.024	2.625	2.500	5.266	.250	HR	170-4-221-1X	232514	170-4-211-1•
-------	-------	-------	-------	------	----	--------------	--------	--------------

2.024	2.625	2.500	5.750	.250	HR	5008578	232514	5001768•
-------	-------	-------	-------	------	----	---------	--------	----------

2.024	2.625	2.500	6.500	.250	HR	170-4-1651-1X•	232514	170-4-1641-1 ▲
-------	-------	-------	-------	------	----	----------------	--------	----------------

2.024	2.625	2.500	6.500	.250	HR	170-4-241-1X	232514	170-4-231-1• High angle yoke
-------	-------	-------	-------	------	----	--------------	--------	---------------------------------

2.024	3.000	2.250	5.031	.280	HR	170-4-861-1X	232200	170-4-841-1
-------	-------	-------	-------	------	----	--------------	--------	-------------

2.024	3.000	2.250	5.031	.280	HR	170-4-851-1X	232199	170-4-841-1
-------	-------	-------	-------	------	----	--------------	--------	-------------

• Part is discontinued ■ Part is available until supply is exhausted ▲ Not sold separately



END YOKES with SPLINED HOLES



Major Diameter	R	Q	S	C'Bore Depth	Style	End Yoke Assy. (includes slinger/plug) Order When Listed	Slinger/Plug Part Number	Spicer Part Number
	Ground Hub Dia.	Length Thru Hole	Centerline to End					
SPL170 SERIES (Continued)				E-6.456 IN. D-2.166 IN.			USE KIT SPL170-3X	
USE BEARING RETAINER KIT NO. 170-70-18X								
2.024-39 Involute Spline (Continued)								
2.024	3.000	2.250	6.250	.306	HR	170-4-811-1X	232200	170-4-801-1■ <i>High angle yoke</i>
2.024	3.000	2.281	5.156	.250	HR	170-4-261-1X	232511	170-4-251-1•
2.024	3.000	2.281	5.540	.250	HR	5008577	232511	5001766•
2.024	3.000	2.281	6.240	.250	HR	170-4-1631-1X•	232511	170-4-1621-1▲
2.024	3.000	2.281	6.240	.250	HR	170-4-281-1X	232511	170-4-271-1▲ <i>High angle yoke</i>
2.024	3.000	2.500	5.280	.280	HR			170-4-821-1
2.024	3.000	2.500	6.500	.280	HR			170-4-831-1 <i>High angle yoke</i>
2.114-32 Involute Spline								
2.114	3.000	2.250	5.000	.424	HR	170-4-901-1X	232200	170-4-891-1▲
2.114	3.000	2.250	6.312	.424	HR	170-4-961-1X	232200	170-4-951-1• <i>High angle yoke</i>
2.143-41 Involute Spline								
2.143	2.938	2.500	5.320	—	HR	170-4-361-1X	232604	170-4-351-1▲
2.143	2.938	2.500	6.680	—	HR	170-4-381-1X	232604	170-4-371-1▲ <i>High angle yoke</i>
2.143	2.938	3.000	5.800	.380	HR	170-4-341-1X	232609	170-4-331-1•
2.143	2.938	3.000	7.190	.380	HR	5008448	232168	170-4-1901-1▲
2.143	2.938	3.000	7.190	.380	HR	170-4-321-1X	232609	170-4-311-1▲ <i>High angle yoke</i>
2.178-43 Involute Spline								
2.178	3.540	2.050	5.340	.157	HR			170-4-1081-1
2.225-6 Spline								
2.225	3.000	3.250	6.030	—	HR			170-4-1441-1
2.250-10 Spline								
2.250	3.500	3.000	5.750	—	HR	170-4-461-1X•	231616	170-4-451-1
2.274-44 Involute Spline								
2.274	2.938	2.350	5.094	—	HR	170-4-31-1X	232604	170-4-21-1▲
2.274	2.938	2.500	5.281	—	HR	170-4-101-1X•	232168	170-4-91-1▲
2.274	3.000	2.500	5.270	.236	HR	170-4-201-1X	232511	170-4-191-1•
2.364-18 Involute Spline								
2.364	3.500	3.375	6.350	—	HR			170-4-1061-1•
2.364-36 Involute Spline								
2.364	3.000	2.685	5.470	—	HR	170-4-1021-1X•	232200	170-4-1011-1▲
2.364	3.000	2.685	6.780	—	HR	170-4-791-1X•	232200	170-4-781-1▲ <i>High angle yoke</i>
2.364	3.500	2.485	5.270	.306	HR	170-4-1041-1X	232201	170-4-1031-1
2.374-46 Spline								
2.374	3.250	2.875	5.760	.140	HR	170-4-581-1X•	231179	170-4-571-1■
2.374	3.250	2.875	5.760	.140	HR	170-4-591-1X	231615	170-4-571-1■
2.374	3.250	2.875	7.250	.140	HR	170-4-611-1X	231615	170-4-601-1▲ <i>High angle yoke</i>
2.374	3.500	2.406	5.880	—	HR	170-4-1221-1X	232042-10	170-4-1211-1•
2.374	3.500	2.406	6.688	—	HR	170-4-1291-1X	232042-10	170-4-1281-1• <i>High angle yoke</i>
2.374	3.750	2.406	5.190	—	HR	170-4-1191-1X		170-4-1171-1▲ <i>Assy includes electronic speedometer gear #231528</i>
2.390-46 Involute Spline								
2.390	2.879	2.750	5.590	.157	HR			170-4-1271-1 <i>Coupling shaft yoke</i>
2.390	3.250	2.328	5.100	.140	HR	170-4-721-1X	231803	170-4-711-1•

• Part is discontinued ■ Part is available until supply is exhausted ▲ Not sold separately



Important: See Safety Information in General Information Section (J300P-GI)

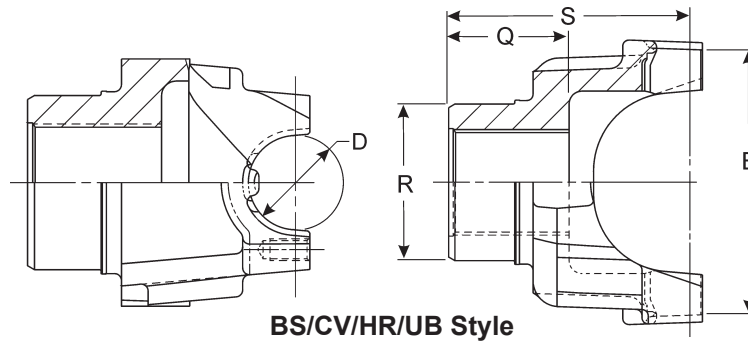

Major Diameter	R	Q	S	C'Bore Depth	Style	End Yoke Assy. (includes slinger/plug) Order When Listed	Slinger/Plug Part Number	Spicer Part Number
	Ground Hub Dia.	Length Thru Hole	Centerline to End					

SPL170 SERIES (Continued) E-6.456 IN. D-2.166 IN. USE KIT SPL170-3X

USE BEARING RETAINER KIT NO. 170-70-18X

2.390-46 Involute Spline (Continued)

2.390	3.250	2.328	5.100	.140	HR	5003558	5003552	170-4-711-1•
2.390	3.250	2.328	6.438	.140	HR	170-4-741-1X	231803	170-4-731-1 ▲ <i>High angle yoke</i>
2.390	3.250	2.875	5.760	.140	HR			170-4-1681-1
2.390	3.375	3.195	6.531	.580	HR	170-4-301-1X	232610	170-4-291-1•

2.500-10 Spline

2.500	3.500	2.406	5.188	—	HR	170-4-1351-1X	232042-11	170-4-1341-1•
2.500	3.750	3.000	5.750	—	HR	170-4-481-1X	231616	170-4-471-1■ <i>Hub machined for speedometer gear</i>

2.544-49 Involute Spline

2.544	3.750	3.000	6.000	—	HR	170-4-421-1X	231616	170-4-411-1 ▲ <i>Hub machined for speedometer gear</i>
2.544	3.818	2.125	6.260	.120	HR	5008451	5008437	170-4-1911-1 ▲ <i>131434K = 5008451 yoke assy & nut# 131095; Spicer axles only</i>
2.544	3.820	2.135	5.530	.120	HR	5008458	5008437	170-4-1891-1• <i>131433K = 5008458 yoke assy & nut# 131095; Spicer axles only</i>
2.544	3.820	2.675	6.810	.240	HR	5008461	5008437	5006714 ▲ <i>132931K = 5008461 yoke assy & nut# 131095; Spicer axles only</i>
2.544	3.820	2.682	6.040	.240	HR	5008444	5008437	5005217 ▲ <i>132863K = 5008444 yoke assy & nut# 131095; Spicer axles only</i>
2.544	4.000	2.750	6.050	.180	HR			170-4-1161-1

2.750-10 Spline

2.750	—	3.000	5.850	—	HR			170-4-531-1• <i>Hub diameter not ground.</i>
2.750	3.500	2.992	6.000	—	HR			170-4-1711-1
2.750	3.750	3.000	5.850	—	HR	170-4-501-1X	230902	170-4-491-1•
2.750	3.750	3.000	5.850	—	HR	170-4-521-1X	231616	170-4-511-1
2.750	4.000	2.935	5.800	—	HR			170-4-1141-1•

2.794-54 Involute Spline

2.794	—	2.750	5.600	—	HR			170-4-561-1 <i>Hub diameter not ground.</i>
-------	---	-------	-------	---	----	--	--	--

2.795-55 Involute Spline

2.795	4.725	2.047	5.200	.150	HR			170-4-1091-1•
-------	-------	-------	-------	------	----	--	--	---------------

SPL250 SERIES E-6.412 IN. D-2.362 IN. USE KIT SPL250X

USE BEARING RETAINED NO. 250-70-18X

2.024-39 Involute Spline

2.024	3.000	2.245	5.240	.280	HR	250-4-391-1X	232199	250-4-381-1•
-------	-------	-------	-------	------	----	--------------	--------	--------------

2.114-32 Involute Spline

2.114	3.000	2.245	5.240	.424	HR	250-4-421-1X	232200	250-4-411-1 ▲
-------	-------	-------	-------	------	----	--------------	--------	---------------

2.143-41 Involute Spline

2.143	2.938	2.500	5.490	—	HR	250-4-141-1X	232604	250-4-131-1 ▲
-------	-------	-------	-------	---	----	--------------	--------	---------------

• Part is discontinued ■ Part is available until supply is exhausted ▲ Not sold separately



END YOKES with SPLINED HOLES



Major Diameter	R	Q	S	C'Bore Depth	Style	End Yoke Assy. (includes slinger/plug) Order When Listed	Slinger/Plug Part Number	Spicer Part Number
	Ground Hub Dia.	Length Thru Hole	Centerline to End					
SPL250 SERIES (Continued)			E-6.412 IN. D-2.362 IN.			USE KIT SPL250X		
USE BEARING RETAINED NO. 250-70-18X								
2.225-6 Spline								
2.225	3.000	3.250	6.240	—	HR	250-4-541-1X	829-W	250-4-531-1 ▲
2.225	3.000	3.250	6.250	—	HR			250-4-811-1
2.274-44 Involute Spline								
2.274	2.938	2.350	5.328	—	HR	250-4-41-1X	232604	250-4-31-1 ▲
2.274	2.938	2.500	5.484	—	HR	250-4-61-1X	232168	250-4-51-1 ▲
2.274	3.000	2.500	5.490	.236	HR	250-4-81-1X	232511	250-4-71-1•
2.364-36 Involute Spline								
2.364	3.000	2.685	5.680	—	HR	250-4-371-1X■	232199	250-4-361-1
2.374-46 Spline								
2.374	3.250	2.625	5.610	—	HR	250-4-781-1X•	231179	250-4-771-1 ▲
2.374	3.250	2.875	5.870	.140	HR	250-4-301-1X	231615	250-4-281-1 ▲
2.374	3.250	2.875	5.870	.140	HR	250-4-291-1X	231179	250-4-281-1 ▲
2.374	3.500	2.406	6.140	—	HR	250-4-651-1X	232042-10	250-4-641-1
2.374	3.750	2.400	6.650	—	HR	250-4-801-1X		250-4-791-1 ▲
2.374	3.750	2.406	5.410	—	HR	250-4-621-1X		250-4-601-1 ▲
<i>Assy includes electronic speedometer gear #231528</i>								
<i>Assy includes electronic speedometer gear #231528</i>								
2.390-46 Involute Spline								
2.390	3.250	2.312	5.312	.140	HR	250-4-351-1X	231803	250-4-341-1•
2.390	3.250	2.312	5.312	.140	HR	5003560	5003552	250-4-341-1•
2.390	3.344	2.750	5.750	—	HR			250-4-21-1
<i>Coupling shaft yoke</i>								
2.390	3.375	3.195	6.760	.580	HR	250-4-101-1X	232610	250-4-91-1 ▲
2.390	3.500	3.375	6.560	—	HR			250-4-471-1•
2.500-10 Spline								
2.500	3.500	2.406	5.500	—	HR	250-4-711-1X	232042-11	250-4-701-1 ▲
2.500	3.750	3.000	6.062	—	HR	250-4-201-1X	231616	250-4-191-1■
<i>Hub machined for speedometer gear</i>								
2.500	3.750	3.000	6.250	—	HR			250-4-561-1
<i>Hub machined for speedometer gear</i>								
2.544-49 Involute Spline								
2.544	3.750	3.000	6.250	—	HR	250-4-161-1X	231616	250-4-151-1 ▲
<i>Hub machined for speedometer gear</i>								
2.544	3.819	2.125	5.830	.120	HR	5008459	5008437	250-4-1021-1 ▲
<i>131435K = 5008459 yoke assy & nut# 131095; Spicer axles only</i>								
2.544	3.819	2.692	6.200	.240	HR	5008445	5008437	250-4-1031-1 ▲
<i>131446K = 5008445 yoke assy & nut# 131095; Spicer axles only</i>								
2.635-20 Involute Spline								
2.635	3.750	2.750	6.270	—	HR	250-4-521-1X	231745	250-4-511-1•
<i>Hub machined for speedometer gear</i>								
2.750-10 Spline								
2.750	—	3.000	6.310	—	HR			250-4-251-1•
2.750	3.500	3.000	6.312	—	HR	250-4-761-1X	230674	250-4-751-1•
2.750	3.750	3.000	6.297	—	HR	250-4-241-1X	231616	250-4-231-1•
2.750	3.750	3.000	6.300	—	HR	250-4-221-1X	230902	250-4-211-1 ▲
2.750	4.000	2.935	6.370	—	HR			250-4-551-1
<i>Hub machined for speedometer gear</i>								
2.794-54 Involute Spline								
2.794	—	2.750	5.703	—	HR			250-4-271-1
<i>Hub diameter not ground.</i>								
2.794	3.750	2.770	6.330	—	HR			250-4-901-1•
2.795-55 Involute Spline								
2.795	4.725	2.047	5.413	.150	HR			250-4-501-1•

• Part is discontinued ■ Part is available until supply is exhausted ▲ Not sold separately



Important: See Safety Information in General Information Section (J300P-GI)

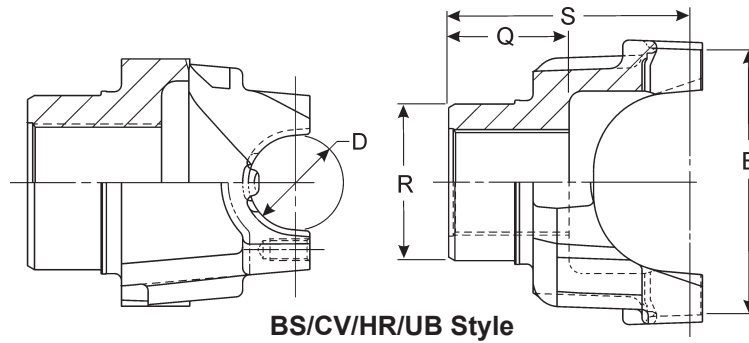

Major Diameter	R	Q	S	C'Bore Depth	Style	End Yoke Assy. (includes slinger/plug) Order When Listed	Slinger/Plug Part Number	Spicer Part Number
	Ground Hub Dia.	Length Thru Hole	Centerline to End					
SPL250 SERIES (Continued)				E-6.412 IN. D-2.362 IN.		USE KIT SPL250X		

USE BEARING RETAINED NO. 250-70-18X

2.922-22 Involute Spline

2.922 4.067 2.645 6.030 .400 HR

250-4-911-1

3.124-48 Involute Spline

3.045 4.250 1.955 5.079 — HR

5005681[▲]
OEM only

• Part is discontinued ■ Part is available until supply is exhausted ▲ Not sold separately



END YOKES with SPLINED HOLES

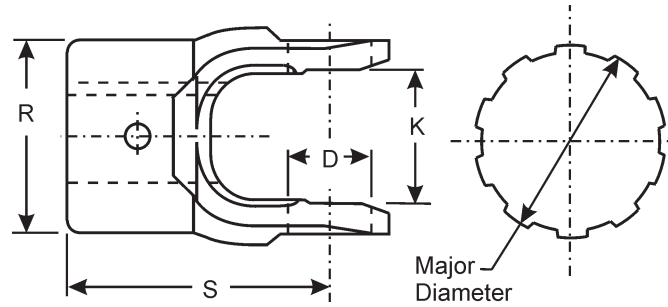

Major Diameter	R	Set Screw Diameter	Pin Hole Diameter	Location Viewed From Hub	S	Spicer Part Number
	Hub Dia.				Centerline to End of Hub	
1000 SERIES	K-1.500	D-.938				USE KIT 5-170X
.875-13 Spline						
1.500	.250	—	6	3.812	10-4-641	
1.625	.375	—	6	2.500	10-4-481	
1.000-6 Spline						
1.625	.375	—	3	2.500	10-4-101	.375 Dia. set screw @ 3 or 9
1.125-6 Spline						
1.625	—	.328	THRU HUB	2.500	10-4-11	.328 dia. pin hole thru hub
1.250-6 Spline						
1.625	—	.328	THRU HUB	2.500	10-4-21	.328 dia. pin hole thru hub
1.375-6 Spline						
2.000	—	.328	THRU HUB	2.500	10-4-31	.328 dia. pin hole thru hub

• Part is discontinued ■ Part is available until supply is exhausted ▲ Not sold separately



Important: See Safety Information in General Information Section (J300P-GI)

END YOKES with SPLINED HOLES

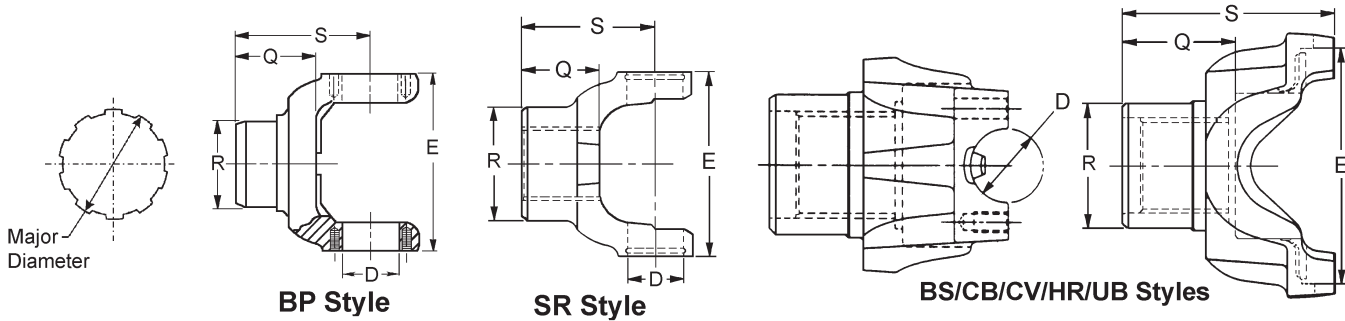

Major Diameter	R Ground Hub Dia.	Q Length Thru Hole	S Centerline to End	C'Bore Depth	Style	End Yoke Assy. (includes slinger) Order When Listed	Slinger/Plug Part Number	Spicer Part Number
1100 SERIES			E-2.656	D-.938			USE KIT 5-101X OR 5-111X	
.878-13 Involute Spline								
.878	2.000	1.250	2.250	—	SR			1-4-1201
1210 SERIES			E-2.438	D-1.062			USE KIT 5-443X	
USES U-BOLT ASSY. 2-94-28X, STRAP ASSY. 2-70-18X								
.984-22 Involute Spline								
.984	1.547	1.297	3.305	—	BS	2-4-7221-1X	42735	2-4-7111-1•
1.031-23 Involute Spline								
1.031	1.562	1.500	3.063	—	BS	2-4-5921-1X	41498	2-4-5911-1•
1.146-26 Involute Spline								
1.146	1.594	1.594	2.938	—	BS	2-4-6731-1X	231596	2-4-6721-1•
								<i>Coupling shaft yoke</i>
1.146	1.625	1.156	2.750	—	BS			2-4-5901-1
1.146	1.625	1.156	3.375	—	CV			2-4-5891•
1.146	1.750	1.375	2.938	—	BS			2-4-6191-1
								<i>Hub diameter not ground.</i>
1310 SERIES			SR: E-3.469	OTHERS E-3.219, D-1.062			USE KIT 5-153X,5-785X,5-810X	
USES U-BOLT ASSY. 2-94-28X, STRAP ASSY. 2-70-18X								
.878-13 Involute Spline								
.878	2.000	1.567	2.562	—	SR			2-4-3331
								<i>.375 Diameter set screw. Hub diameter not ground</i>
.970-29 Involute Spline								
.970	1.500	1.500	3.000	.299	BS			2-4-8031-1•
.984-10 Spline								
.984	1.562	1.938	3.656	—	UB			2-4-1721
1.010-15 Involute Spline								
1.010	1.594	2.656	3.562	—	SR			2-4-4931
1.010	2.120	1.240	2.312	—	SR			2-4-4921
								<i>Hub diameter not ground.</i>
1.010	2.120	1.470	2.500	—	SR			2-4-8241
								<i>.375 Diameter set screw. Hub diameter not ground</i>
1.026-23 Involute Spline								
1.026	1.552	1.500	3.000	—	BS	2-4-6131-1X	41498	2-4-6121-1•
1.070-16 Involute Spline								
1.070	1.625	1.750	3.219	.201	BS	2-4-6981-1X•	—	2-4-6661-1▲
								<i>Assembly includes Balance Disc #231901</i>
1.125-10 Spline								
1.125	1.552	1.500	3.000	—	UB	2-4-2821X•	15099	2-4-2791•
1.125	1.552	1.500	3.000	—	BS	2-4-2821-1X	15099	2-4-2791-1▲
1.125	1.552	1.500	3.000	—	BS	2-4-2801-1X	31875	2-4-2791-1▲
1.125	1.552	1.500	3.000	.310	BS	2-4-2851-1X•	330851	2-4-2841-1•
1.125	1.552	1.500	3.000	.311	CV	2-4-4061X	330699	2-4-4051•

• Part is discontinued ■ Part is available until supply is exhausted ▲ Not sold separately



Major Diameter	R	Q	S	C'Bore Depth	Style	End Yoke Assy. (includes slinger/plug) Order When Listed	Slinger/Plug Part Number	Spicer Part Number
	Ground Hub Dia.	Length Thru Hole	Centerline to End					
1310 SERIES (Continued) SR: E-3.469 OTHERS E-3.219, D-1.062 USE KIT 5-153X,5-785X,5-810X								
USES U-BOLT ASSY. 2-94-28X, STRAP ASSY. 2-70-18X								
1.146-26 Involute Spline								
1.146	1.375	1.750	3.125	—	SR			2-4-3161
1.146	1.453	1.500	3.000	—	BS	2-4-6411-1X•	231877	2-4-6401-1• <i>Coupling shaft yoke</i>
1.146	1.467	1.500	3.000	—	BS	2-4-6181-1X•	231579	2-4-6171-1▲ <i>Coupling shaft yoke</i>
1.146	1.469	1.465	3.500	—	BS	2-4-8191-1X•	231579	2-4-8181-1▲ <i>High angle yoke</i>
1.146	1.469	1.484	3.500	—	BS	2-4-7501-1X	231579	2-4-7491-1• <i>Coupling shaft yoke</i>
1.146	1.484	1.484	3.000	—	BS	2-4-7291-1X	232020	2-4-7401-1▲ <i>Coupling shaft yoke</i>
1.146	1.500	1.465	3.000	—	BS	2-4-8701-1X•	231970	2-4-8691-1▲ <i>Coupling shaft yoke</i>
1.146	1.500	1.469	3.000	—	BS			2-4-7021-1 <i>Coupling shaft yoke; Hub diameter not ground</i>
1.146	1.500	1.736	3.270	—	BS	2-4-8541-1X•	232911-1	2-4-8531-1▲ <i>Coupling shaft yoke; Hub diameter not ground</i>
1.146	1.513	2.000	3.300	—	SR	2-4-8171X•	232184	2-4-8161• <i>Coupling shaft yoke</i>
1.146	1.552	1.495	2.995	—	BS			2-4-6561-1
1.146	1.552	1.500	2.914	—	BS			2-4-8321-1•
1.146	1.552	1.500	3.000	—	CV			2-4-4341
1.146	1.552	1.500	3.000	—	BS			2-4-6641-1
1.146	1.552	1.500	3.000	—	BS			2-4-6781-1
1.146	1.552	1.500	3.000	—	UB			2-4-7871•
1.146	1.552	1.500	3.000	—	BS			2-4-7871-1•
1.146	1.552	1.500	3.000	—	UB	2-4-8091X	41498	2-4-8081•
1.146	1.552	1.500	3.000	—	BS	2-4-8091-1X	41498	2-4-8081-1•
1.146	1.552	1.500	3.406	—	UB	2-4-5251X•	41498	2-4-5241▲ <i>Spec. yoke w/1.125 dia. brg. caps</i>
1.146	1.552	1.500	3.156	—	BS	2-4-5331X	15099	2-4-5321• <i>Attaching hardware by OEM</i>
1.146	1.552	1.500	3.000	—	BS			2-4-2271-1
1.146	1.844	1.370	3.130	.120	BS	2-4-8551-1X	232816	2-4-8521-1•
1.146	1.844	1.370	3.235	.120	BS			2-4-8311-1
1.146	1.844	1.375	2.938	.120	BS			2-4-4601-1
1.146	1.844	1.375	2.938	.120	BS	2-4-6901-1X	42779	2-4-6891-1▲
1.172-27 Involute Spline								
1.172	1.688	1.062	2.750	—	BS			2-4-5851-1
1.172-9 Based On 10 Spline								
1.172	1.250	1.438	2.469	—	SR			2-4-1921 <i>Hub diameter not ground.</i>
1.183-6 Spline								
1.183	1.620	1.500	2.935	—	UB			2-4-1301 <i>.188 Dia drilled hole thru hub</i>
1.215-18 Involute Spline								
1.215	2.120	1.500	2.562	—	SR			2-4-6301 <i>Hub diameter not ground.</i>
1.229-28 Involute Spline								
1.229	1.844	1.375	2.938	.120	BS			2-4-3741-1
1.229	1.844	1.375	2.938	.120	BS	2-4-7371-1X■	231935-1	2-4-6161-1 <i>Zinc plated slinger</i>

• Part is discontinued ■ Part is available until supply is exhausted ▲ Not sold separately



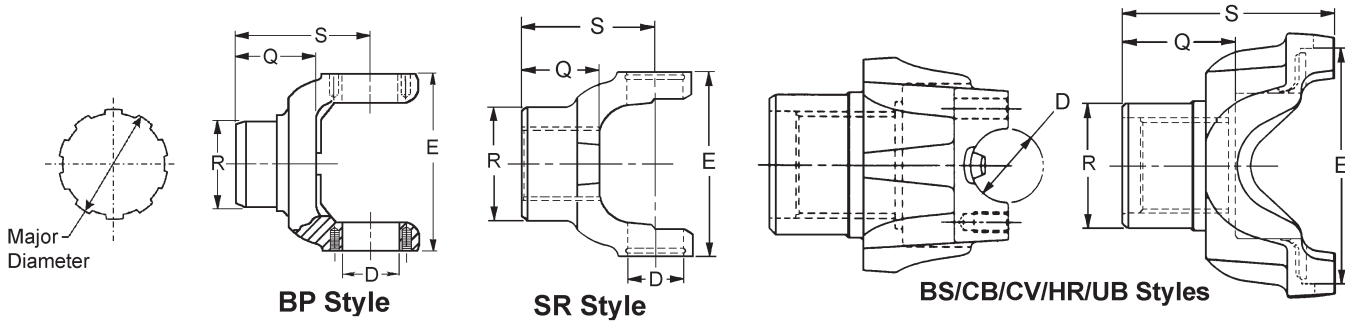

Major Diameter	R	Q	S	C'Bore Depth	Style	End Yoke Assy. (includes slinger) Order When Listed	Slinger/Plug Part Number	Spicer Part Number
	Ground Hub Dia.	Length Thru Hole	Centerline to End					

1310 SERIES (Continued) SR: E-3.469 OTHERS E-3.219, D-1.062 USE KIT 5-153X,5-785X,5-810X
USES U-BOLT ASSY. 2-94-28X, STRAP ASSY. 2-70-18X

1.250-10 Spline

1.250	1.750	2.000	3.375	—	CV	2-4-4021X	230881	2-4-4011•
1.250	1.750	2.000	3.625	—	UB			2-4-1831
1.250	1.875	1.500	2.938	—	BS	2-4-1991-1X	30798	2-4-1981-1▲
1.250	1.875	1.500	2.938	—	UB	2-4-2611X	230421	2-4-2601•
1.250	1.875	1.500	2.938	—	BS	2-4-2611-1X	230421	2-4-2601-1•
1.250	2.000	1.750	3.281	—	UB	2-4-4471X	500166-24	2-4-2901
1.250	2.000	1.750	3.625	—	UB			2-4-7731•

1.268-14 Involute Spline

1.268	2.000	2.500	3.688	—	SR			2-4-5411
								.375 Dia.set screw @ 6 OR 12, hub diameter not ground.
1.268	2.120	1.500	2.562	—	SR			2-4-1741
1.268	2.125	1.953	3.453	—	BS			2-4-7141-1

1.274-19 Involute Spline

1.274	2.000	1.344	2.500	—	SR			2-4-6341
								Hub diameter not ground.

1.276-29 Involute Spline

1.276	1.875	1.500	2.531	—	UB	2-4-3781X	30798	2-4-3771•
1.276	1.875	1.500	2.938	—	UB	2-4-3801X	34592	2-4-3791•
1.276	1.875	1.500	2.938	—	BS	2-4-3801-1X	34592	2-4-3791-1•
1.276	1.875	1.500	2.996	—	BS	2-4-8391-1X	34592	2-4-8331-1•

1.326-30 Involute Spline

1.326	1.750	2.000	3.375	—	CV	2-4-5421X	230881	2-4-4801•
-------	-------	-------	-------	---	----	-----------	--------	-----------

1.375-10 Spline

1.375	2.000	2.000	3.438	.250	UB			2-4-2371
1.375	1.719	1.500	2.938	—	UB			2-4-411
1.375	1.750	1.750	3.219	—	UB			2-4-2671
								Hub diameter not ground. Coupling shaft yoke
1.375	2.125	1.156	2.594	—	BS			2-4-6001-1
1.375	2.125	1.375	2.938	—	UB			2-4-6011
1.375	2.125	1.375	2.938	—	UB			2-4-7151
1.375	2.125	2.000	3.438	—	UB			2-4-1731
								Hub diameter not ground.
1.375	2.125	2.000	3.438	—	UB	2-4-2411X•	230421	2-4-2401•
1.375	2.125	2.000	3.438	—	BS	2-4-2411-1X	230421	2-4-2401-1
1.375	2.125	2.000	3.469	—	BS			2-4-6671-1•

1.375-6 Spline

1.375	2.125	1.500	2.969	—	UB			2-4-1311
-------	-------	-------	-------	---	----	--	--	----------

1.377-21 Involute Spline

1.377	2.125	1.469	2.562	—	SR			2-4-5781
								Hub diameter not ground.

• Part is discontinued

■ Part is available until supply is exhausted

▲ Not sold separately



Major Diameter	R	Q	S	C'Bore Depth	Style	End Yoke Assy. (includes slinger/plug) Order When Listed	Slinger/Plug Part Number	Spicer Part Number
	Ground Hub Dia.	Length Thru Hole	Centerline to End					
1310 SERIES (Continued) SR: E-3.469 OTHERS E-3.219, D-1.062 USE KIT 5-153X,5-785X,5-810X								
USES U-BOLT ASSY. 2-94-28X, STRAP ASSY. 2-70-18X								
1.383-21 Involute Spline								
1.383	2.250	1.650	3.115	—	BS			2-4-7801-1 <i>Hub diameter not ground.</i>
1.400-32 Involute Spline								
1.400	2.125	2.000	3.438	—	BS			2-4-4191-1
1.401-32 Involute Spline								
1.401	1.875	2.000	3.875	—	CV			2-4-5341
1.403-21 Involute Spline								
1.403	1.620	1.562	3.000	—	CV			2-4-5091 <i>Hub diameter not ground. Flats on hub, slot thru hub, drilled hole thru hub</i>
1.403	2.125	1.125	2.594	—	BS			2-4-5991-1
1.500-10 Spline								
1.500	2.125	1.734	3.500	—	BS			2-4-7181-1 <i>Hub diameter not ground.</i>
1330 SERIES SR: E-3.875 OTHERS: E-3.625, D-1.062 USE KIT 5-213X,5-790X, 5-812X								
USES U-BOLT ASSY. 2-94-28X, STRAP ASSY. 2-70-18X								
1.118-27 Involute Spline								
1.118	1.970	1.785	3.772	.276	BS	5003952	5003953	5002013▲
1.146-26 Involute Spline								
1.146	1.552	1.500	3.000	—	BS	2-4-3581-1X	41498	2-4-3571-1▲
1.146	1.844	1.375	3.562	.120	BS			2-4-7631-1 <i>High angle yoke</i>
1.200-29 Involute Spline								
1.200	1.653	1.799	3.772	.335	BS	5003950	5003951	5002012▲
1.200	1.653	1.799	3.772	.335	BS	5003954	5003955	5002015▲
1.202-17 Involute Spline								
1.202	1.688	1.719	3.188	.460	BS	2-4-5691-1X•	231302	2-4-5681-1•
1.229-28 Involute Spline								
1.229	1.844	1.375	2.938	.120	BS	2-4-7031-1X	231935-1	2-4-6851-1■ <i>Zinc plated slinger</i>
1.276-29 Involute Spline								
1.276	1.875	1.500	2.938	—	BS	2-4-4291-1X	34592	2-4-4031-1
1.276	1.875	1.500	2.938	—	BS	2-4-8051-1X	41195	2-4-8041-1▲
1.276	1.875	1.500	3.188	—	BS			2-4-8421-1
1.401-32 Involute Spline								
1.401	1.875	2.000	3.875	—	CV			2-4-5441
1.401	2.125	2.000	3.438	—	BS			2-4-5521-1
1.403-21 Involute Spline								
1.403	1.906	1.719	3.594	—	CV			2-4-6221 <i>Flats on hub, slot thru hub, drilled hole thru hub</i>
1.403	2.000	2.531	4.062	.240	CV			2-4-6231• <i>Hub diameter not ground.</i>
1330-F SERIES SR: E-3.875 OTHERS E-3.625 D-1.125 USE KIT 5-1204X, 5-792X								
USES U-BOLT ASSY NO. 2-94-58X								
1.146-26 Involute Spline								
1.146	1.562	1.500	3.000	—	UB	2-4-6111X	41498	2-4-6101•
1.276-29 Involute Spline								
1.276	1.875	1.500	2.938	—	UB	2-4-5311X	34592	2-4-5301•
1.276	1.875	1.500	2.938	—	UB	2-4-8051X■	41195	2-4-8041▲
1340 SERIES E-3.953 D-1.250 USE KIT NO. 5-243X								
1.375-6 Spline								
1.375	2.375	1.750	3.875	—	SR			3-4-5341•
1.375	2.375	1.875	3.875	—	SR			3-4-5101■

• Part is discontinued ■ Part is available until supply is exhausted ▲ Not sold separately



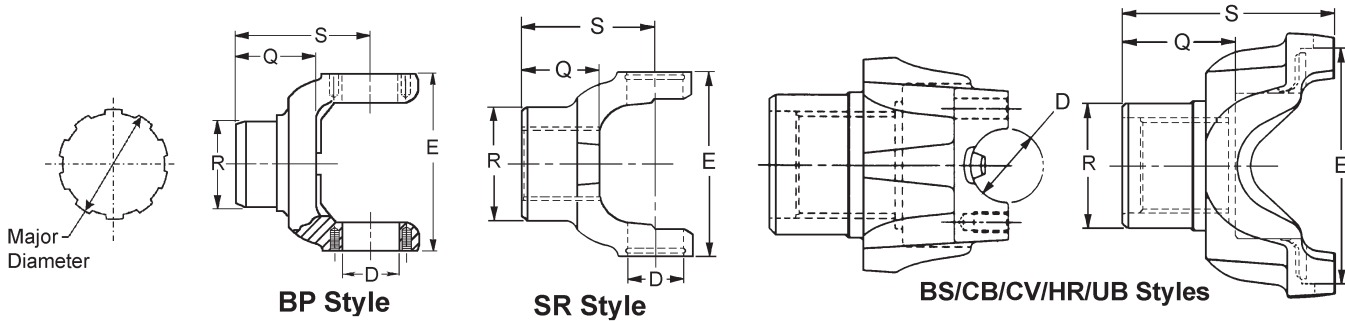

Major Diameter	R	Q	S	C'Bore Depth	Style	End Yoke Assy. (includes slinger) Order When Listed	Slinger/Plug Part Number	Spicer Part Number
	Ground Hub Dia.	Length Thru Hole	Centerline to End					
1350 SERIES								
SR: E-3.875 OTHERS: E-3.625, D-1.188						USE KIT 5-178X, 5-799X		
USES U-BOLT ASSY. 3-94-18X, STRAP ASSY. 3-70-28X								
.970-29 Involute Spline								
.970	1.500	1.500	3.547	.299	BS			3-4-11721-1
1.125-10 Spline								
1.125	1.552	1.500	3.000	—	BS			3-4-2111-1
1.146-26 Involute Spline								
1.146	1.550	1.500	3.000	—	BS			3-4-13761-1
1.146	1.562	1.500	3.000	—	BS	3-4-5761-1X	15099	3-4-5751-1 ▲
1.181-10 Spline								
1.181	1.875	1.656	3.125	—	BS			3-4-2051-1
1.194-46 Involute Spline								
1.194	2.000	2.203	3.938	—	BS			3-4-9821-1
1.209-27 Involute Spline								
1.209	1.516	1.469	3.250	.290	BS	3-4-11911-1X	232064	3-4-9941-1
1.209	1.516	1.469	3.328	.290	BS	3-4-11231-1X•	231636	3-4-11221-1 ▲
1.229-28 Involute Spline								
1.229	1.844	1.375	3.031	.120	BS	3-4-11931-1X	231935-1	3-4-11901-1• <i>Zinc plated slinger</i>
1.250-10 Spline								
1.250	2.125	1.750	3.312	—	UB			3-4-2781•
1.268-14 Involute Spline								
1.268	—	—	2.688	—	SR			3-4-13161
1.276-29 Involute Spline								
1.276	1.810	1.495	2.995	—	BS			3-4-14621-1 <i>Coupling shaft yoke</i>
1.276	1.875	1.500	3.000	—	BS			3-4-12211-1■
1.276	1.875	1.500	3.000	—	BS	3-4-13031-1X•	45799	3-4-12771-1•
1.276	1.875	1.500	3.000	—	BS	3-4-12781-1X▲	34592	3-4-12771-1•
1.276	1.875	1.500	3.000	—	BS	3-4-13031-2X	45799	3-4-12771-2▲ <i>Attaching hardware by OEM</i>
1.276	1.875	1.500	3.000	—	BS	3-4-14541-1X▲	34592	3-4-14531-1
1.276	1.875	1.500	3.000	—	BS	3-4-14701-1X•	52392	3-4-14671-1▲
1.276	1.875	1.500	3.000	—	BS	3-4-5731-1X	34592	3-4-5721-1
1.282-15 Involute Spline								
1.282	1.810	1.450	3.030	—	BS			3-4-11421-1• <i>Hub diameter not ground.</i>
1.282	1.812	1.600	3.031	—	BS			3-4-11441-1• <i>Hub diameter not ground.</i>
1.282	1.970	2.250	3.875	—	BS			3-4-13601-1 <i>Hub diameter not ground.</i>

• Part is discontinued

■ Part is available until supply is exhausted

▲ Not sold separately



Major Diameter	R	Q	S	C'Bore Depth	Style	End Yoke Assy. (includes slinger/plug) Order When Listed	Slinger/Plug Part Number	Spicer Part Number
	Ground Hub Dia.	Length Thru Hole	Centerline to End					
1350 SERIES (Continued) SR: E-3.875 OTHERS: E-3.625, D-1.188						USE KIT 5-178X, 5-799X		
USES U-BOLT ASSY. 3-94-18X, STRAP ASSY. 3-70-28X								
1.284-14 Involute Spline								
1.284	2.000	1.438	2.688	—	SR	3-4-5391X	230859	3-4-5301
1.284	2.000	1.719	2.688	—	SR			3-4-7401
						<i>.375 Dia.set screw @ 6 OR 12, hub diameter not ground.</i>		
1.312-30 Involute Spline								
1.312	1.938	1.156	3.125	—	BS	3-4-8691-1X	231356	3-4-8681-1
1.375-10 Spline								
1.375	1.703	1.375	2.922	—	BS			3-4-11711-1
1.375	1.719	1.781	3.281	—	BS	3-4-178-1X	98-1473	3-4-2171-1•
						<i>Coupling shaft yoke</i>		
1.375	1.719	2.000	3.500	—	BS			3-4-1261-1
1.375	1.750	1.812	3.312	—	BS			3-4-1111-1
1.375	2.000	2.000	3.500	.250	BS			3-4-1211-1
1.375	2.000	2.188	4.281	.250	UB	3-4-1371-1	—	3-4-1371•
1.375	2.125	2.000	3.500	—	BS			3-4-3951-1
1.375	2.125	2.000	3.688	—	BS			3-4-3291-1
1.378-31 Based On 32 Spline								
1.378	1.885	4.094	5.594	—	BS			3-4-13211-1
						<i>Uses GM brg. strap</i>		
1.378	1.885	4.094	5.594	—	BS			3-4-13731-1
						<i>Nickel plated; uses GM brg. strap</i>		
1.378-32 Involute Spline								
1.378	2.000	1.375	3.000	—	SR			3-4-12611•
1.401-32 Involute Spline								
1.401	2.125	2.000	3.500	—	BS			3-4-6211-1
1.401	2.125	2.719	4.750	—	UB			3-4-7241•
1.401	2.125	2.719	4.750	—	BS			3-4-7241-1
1.403-21 Involute Spline								
1.403	1.938	1.938	3.844	—	BS	3-4-13011-1X	2-68-104	3-4-13001-1•
1.403	1.938	2.045	3.835	—	BS			3-4-14461-1
1.403	2.000	1.234	2.953	—	BS			3-4-10591-1
1.403	2.000	2.245	4.285	—	BS			3-4-14451-1
1.498-29 Involute Spline								
1.498	1.969	1.828	3.922	—	BS			3-4-10281-1•
1.498	1.969	2.837	4.984	1.026	BS			3-4-12461-1
1.500-10 Spline								
1.500	1.810	2.000	3.695	—	BS			3-4-13881-1
						<i>Coupling shaft yoke; Hub diameter not ground</i>		
1.500	2.250	2.000	3.500	—	BS			3-4-1441-1
1.500	2.250	2.063	3.530	—	BS			3-4-1501-1
1.500	2.253	2.185	3.905	—	BS	3-4-3671-1X•	230386	3-4-2231-1
1.500	2.500	2.000	3.766	.540	BS			3-4-8511-1
1.511-14 Involute Spline								
1.511	2.125	2.531	4.500	—	BS			3-4-8501-1
1.511	2.375	1.828	3.312	—	BS			3-4-8491-1•
1.625-10 Spline								
1.625	2.375	2.125	3.969	—	UB	3-4-9001X•	230895	3-4-3931•
1.625	2.375	2.125	3.969	—	BS	3-4-9001-1X•	230895	3-4-3931-1•
1.750-10 Spline								
1.750	2.375	1.812	3.500	—	BS			3-4-3801-1
1.750	2.375	2.188	4.000	—	BS			3-4-2351-1

• Part is discontinued ■ Part is available until supply is exhausted ▲ Not sold separately



Important: See Safety Information in General Information Section (J300P-GI)

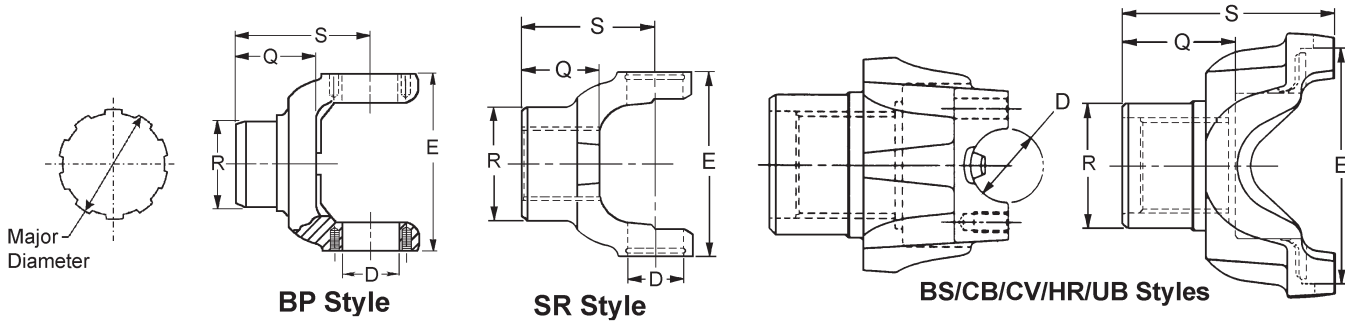

Major Diameter	R	Q	S	C'Bore Depth	Style	End Yoke Assy. (includes slinger) Order When Listed	Slinger/Plug Part Number	Spicer Part Number
	Ground Hub Dia.	Length Thru Hole	Centerline to End					
1410 SERIES			SR: E-4.438 OTHERS: E-4.188, D-1.188			USE KIT 5-160X, 5-801X		
USES U-BOLT ASSY, 3-94-18X, STRAP KIT 3-70-28X								
1.250-10 Spline								
1.250	1.875	1.500	3.188	—	BS	3-4-4451-1X	30798	3-4-4441-1 ▲
1.260-23 Involute Spline								
1.260	1.565	1.609	3.562	.360	BS			3-4-10941-1
1.268-14 Involute Spline								
1.268	1.516	1.750	2.750	—	SR			3-4-5321
								<i>Hub diameter not ground.</i>
1.268	2.250	2.125	4.031	—	BS	3-4-9561-1X	2-68-293	3-4-9551-1 w/zerk fitting
1.268	2.375	2.250	4.031	—	BS			3-4-7721-1
								<i>.375 Dia.set screw @ 6 OR 12, hub diameter not ground.</i>
1.276-29 Involute Spline								
1.276	1.810	1.500	3.200	—	BS			3-4-14591-1
								<i>Coupling shaft yoke</i>
1.276	1.874	1.420	3.185	—	BS	3-4-11891-1X	34592	3-4-11851-1
1.276	1.875	1.500	3.188	—	BS	3-4-5711-1X	34592	3-4-5701-1•
1.276	1.875	1.500	3.188	—	BS			3-4-8731-1
1.276	1.875	1.500	3.200	—	BS	3-4-14711-1X	52392	3-4-14681-1 ▲
								<i>Attaching hardware by OEM</i>
1.375-10 Spline								
1.375	1.719	1.781	3.469	—	BS	3-4-2851-1X	98-1473	3-4-2841-1•
								<i>Hub diameter not ground.</i>
1.375	1.719	2.000	3.703	—	BS			3-4-1471-1
1.375	1.875	1.688	3.500	—	BS	3-4-12541-1X•	2-68-164	3-4-12531-1 ▲
1.375	1.938	2.000	3.688	—	BS			3-4-1481-1
1.375	2.125	2.000	3.685	—	BS			3-4-2271-1
1.375	2.500	1.938	5.750	—	BS			3-4-7141
								<i>Flanged end yoke, strap kit not furnished by Dana</i>
1.375-32 Involute Spline								
1.375	1.886	2.000	3.675	—	BS			3-4-13511-1
								<i>Uses GM brg. strap</i>
1.383-21 Involute Spline								
1.383	2.625	3.312	4.641	1.190	BS			3-4-11471-1
1.400-32 Involute Spline								
1.400	2.125	2.000	3.688	—	BS			3-4-10951-1
1.498-29 Involute Spline								
1.498	1.969	1.828	3.938	—	BS			3-4-10571-1•
1.498	2.000	1.609	3.688	—	BS			3-4-10931-1
1.500-10 Spline								
1.500	1.812	2.000	3.719	—	BS	3-4-6631-1X	231004	3-4-6561-1
								<i>Coupling shaft yoke</i>
1.500	2.125	2.000	3.688	.250	BS			3-4-1901-1

• Part is discontinued ■ Part is available until supply is exhausted ▲ Not sold separately



END YOKES with SPLINED HOLES



Major Diameter	R	Q	S	C'Bore Depth	Style	End Yoke Assy. (includes slinger/plug) Order When Listed	Slinger/Plug Part Number	Spicer Part Number
	Ground Hub Dia.	Length Thru Hole	Centerline to End					
1410 SERIES (Continued) SR: E-4.438 OTHERS: E-4.188, D-1.188						USE KIT 5-160X, 5-801X		
USES U-BOLT ASSY, 3-94-18X, STRAP KIT 3-70-28X								
1.500-10 Spline (Continued)								
1.500	2.125	2.000	3.688	—	BS			3-4-3961-1
1.500	2.125	2.188	3.875	—	UB			3-4-6531■
1.500	2.250	1.750	3.750	—	BS			3-4-1911-1•
1.500	2.250	2.188	3.875	—	BS			3-4-2241-1
1.500	2.312	2.000	3.688	—	BS	3-4-7321-1X	230124	3-4-2941-1
1.500	2.406	2.000	3.688	—	UB			3-4-6751•
1.500	2.625	2.000	3.844	—	BS			3-4-10551-1 <i>Coupling shaft yoke</i>
1.500-10 Involute Spline								
1.500	1.810	2.000	3.690	—	BS			3-4-13871-1■ <i>Coupling shaft yoke; Hub diameter not ground</i>
1.506-23 Involute Spline								
1.506	2.375	1.406	3.500	.240	BS			3-4-11811-1
1.525-35 Involute Spline								
1.525	2.125	2.000	3.688	—	BS			3-4-5191-1
1.525	2.500	1.938	3.750	—	BS			3-4-9251-2 <i>Attaching hardware by OEM</i>
1.525	2.500	1.938	5.750	—	BS			3-4-7151 <i>Flanged end yoke, strap kit not furnished by Dana</i>
1.527-22 Based On 23 Spline								
1.527	1.889	2.678	4.425	.080	BS			3-4-11741-1•
1.527	1.890	1.605	3.500	—	BS			3-4-11591-1
1.527	1.890	1.614	3.500	—	BS			3-4-10231-1■
1.588-24 Involute Spline								
1.588	2.250	2.125	4.000	.470	BS	3-4-11701-1X	3-68-124	3-4-8701-1•
1.590-30 Involute Spline								
1.590	2.200	1.625	3.719	—	BS	3-4-8001-1X	232037	3-4-7991-1•
1.609-15 Involute Spline								
1.609	2.125	1.938	3.750	—	BS			3-4-7311-1
1.609-37 Involute Spline								
1.609	2.500	2.000	4.300	.240	BS	3-4-14721-1X•	84406	3-4-14371-1
1.609	2.500	2.000	4.300	.240	BS	3-4-14391-1X	232895	3-4-14371-1
1.609	2.500	2.000	4.312	.240	BS	3-4-11081-1X	231872	3-4-9931-1•
1.625-10 Spline								
1.625	2.375	2.125	3.938	—	BS			3-4-3491-1
1.625	2.375	2.125	4.188	—	BS	3-4-5921-1X	230895	3-4-2131-1•
1.650-16 Involute Spline								
1.650	2.375	2.000	3.812	—	UB			3-4-2281•
1.750-10 Spline								
1.750	2.250	2.188	4.188	—	UB			3-4-3351•
1.750	2.359	2.094	4.203	—	BS			3-4-11761-1
1.750	2.375	1.938	3.969	—	BS			3-4-8031-1
1.750	2.375	2.188	4.188	—	BS			3-4-1161-1
1.750	2.375	2.188	4.188	—	BS			3-4-1841-1
1.750	2.500	1.938	5.750	—	BS			3-4-7131 <i>Flanged end yoke, strap kit not furnished by Dana</i>
1.750	2.501	2.000	4.000	.250	BS			3-4-13911-1
1.750	2.625	2.188	4.000	—	BS	3-4-5881-1X	230909	3-4-3041-1 <i>.250 deep spline chamfer</i>
1.750	2.625	2.188	4.250	—	BS			3-4-2511-1 <i>.250 deep spline chamfer</i>
1.750	2.625	2.188	4.250	—	BS			3-4-7031-1 <i>.250 deep spline chamfer</i>

• Part is discontinued ■ Part is available until supply is exhausted ▲ Not sold separately



Important: See Safety Information in General Information Section (J300P-GI)

END YOKES with SPLINED HOLES

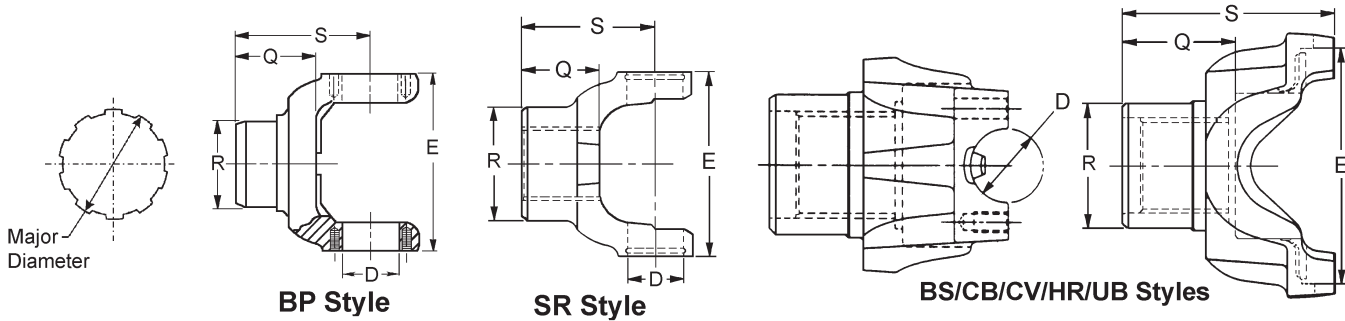

Major Diameter	R	Q	S	C'Bore Depth	Style	End Yoke Assy. (includes slinger) Order When Listed	Slinger/Plug Part Number	Spicer Part Number
	Ground Hub Dia.	Length Thru Hole	Centerline to End					

1410 SERIES (Continued) SR: E-4.438 OTHERS: E-4.188, D-1.188 USE KIT 5-160X, 5-801X

USES U-BOLT ASSY, 3-94-18X, STRAP KIT 3-70-28X

1.751-27 Involute Spline

1.751	2.625	1.438	3.465	—	BS			3-4-10541-1•
1.751	2.780	2.060	4.230	—	BS			5004785

Hub diameter not ground.

1.774-34 Involute Spline

1.774	2.500	2.250	4.188	—	UB	3-4-8061X	231206	3-4-7551
-------	-------	-------	-------	---	----	-----------	--------	----------

3-4-7551 was replaced by 3-4-8061X

1.784-27 Involute Spline

1.784	2.625	2.000	4.000	—	BS			3-4-8721-1
-------	-------	-------	-------	---	----	--	--	------------

Flanged end yoke.

1.790-34 Involute Spline

1.790	2.625	2.188	4.031	—	BS	3-4-10461-1X	232039	3-4-10251-1
-------	-------	-------	-------	---	----	--------------	--------	-------------

1.878-14 Involute Spline

1.878	2.564	2.015	4.219	—	UB			3-4-8071•
1.878	2.564	2.015	4.219	—	BS			3-4-8071-1•

1.972-10 Spline

1.972	2.594	1.844	3.969	—	BS			3-4-2251-1
-------	-------	-------	-------	---	----	--	--	------------

1480 SERIES SR: E-4.438 OTHERS: E-4.188, D-1.375 USE KIT 5-188X, 5-803X

USES U-BOLT ASSY NO.3-94-28X, STRAP ASSY. 3-70-38X

1.276-29 Involute Spline

1.276	1.875	1.500	3.500	—	BS	3-4-13391-1X	34592	3-4-9531-1•
-------	-------	-------	-------	---	----	--------------	-------	-------------

1.375-10 Spline

1.375	2.125	2.000	3.859	—	SR			3-4-13021•
1.375	2.125	2.000	4.031	—	BS			3-4-6701-1
1.375	2.125	2.000	4.031	—	UB			3-4-6701•

1.500-10 Spline

1.500	1.810	2.000	4.025	—	BS			3-4-13921-1•
<i>Coupling shaft yoke; Hub diameter not ground</i>								
1.500	1.810	2.000	4.031	—	BS	3-4-7391-1X•	231004	3-4-6901-1
1.500	1.810	2.000	4.031	—	BS			3-4-6901-2
<i>Attaching hardware by OEM</i>								
1.500	1.938	2.000	4.031	—	BS	3-4-4421-1X	230124	3-4-3091-1
<i>Coupling shaft yoke</i>								
1.500	2.062	2.000	4.031	—	UB	3-4-3331X•	230207	3-4-3081•
<i>Coupling shaft yoke; Hub diameter not ground</i>								
1.500	2.062	2.000	4.031	—	BS	3-4-3331-1X•	230207	3-4-3081-1
<i>Coupling shaft yoke; Hub diameter not ground</i>								
1.500	2.125	2.000	4.219	.250	BS			3-4-3111-1
1.500	2.125	2.120	3.660	—	BS			3-4-7781•
<i>Flanged end yoke.</i>								

• Part is discontinued

■ Part is available until supply is exhausted

▲ Not sold separately



END YOKES with SPLINED HOLES



Major Diameter	R	Q	S	C'Bore Depth	Style	End Yoke Assy. (includes slinger/plug) Order When Listed	Slinger/Plug Part Number	Spicer Part Number
	Ground Hub Dia.	Length Thru Hole	Centerline to End					
1480 SERIES (Continued) SR: E-4.438 OTHERS: E-4.188, D-1.375							USE KIT 5-188X, 5-803X	
USES U-BOLT ASSY NO.3-94-28X, STRAP ASSY. 3-70-38X								
1.500-10 Spline (Continued)								
1.500	2.125	2.188	4.250	—	UB	3-4-6261X•	230895	3-4-6251•
1.500	2.250	2.188	4.200	—	BS	3-4-6221-1X	230895	3-4-3781-1
1.500	2.250	2.188	4.406	—	BS			3-4-3241-1
1.506-23 Involute Spline								
1.506	2.375	1.403	3.500	.240	BS			3-4-14031-1
1.525-35 Involute Spline								
1.525	2.500	1.938	5.750	—	UB			3-4-7161• <i>Flanged end yoke.</i>
1.533-17 Involute Spline								
1.533	2.120	1.950	4.000	—	BS			3-4-13791-1•
1.605-15 Involute Spline								
1.605	2.125	1.938	4.000	—	BS			3-4-9301-1
1.609-37 Involute Spline								
1.609	2.500	2.000	4.328	.240	BS	3-4-14731-1X•	84406	3-4-11171-1▲
1.609	2.500	2.000	4.328	.240	BS	3-4-11281-1X	231872	3-4-11171-1▲
1.625-10 Spline								
1.625	2.375	2.125	4.188	—	BS	3-4-5781-1X•	230895	3-4-3141-1▲
1.625	2.375	2.125	4.312	—	UB			3-4-3771•
1.625-26 Involute Spline								
1.625	1.938	2.000	4.688	—	UB			3-4-9031•
1.750-10 Spline								
1.750	2.250	2.188	4.250	—	BS	3-4-6241-1X•	230895	3-4-6231-1•
1.750	2.250	2.188	4.406	—	BS			3-4-7361-1
1.750	2.362	2.120	4.215	—	BS			3-4-13821-1
1.750	2.362	2.125	4.214	—	BS			3-4-14551-1
1.750	2.375	2.188	4.219	—	BS			3-4-3191-1
1.750	2.375	2.188	4.219	—	BS			3-4-3571-1
1.750	2.500	1.922	3.859	—	UB			3-4-5911•
1.750	2.500	1.922	5.109	—	BS			3-4-11561-1
1.750	2.500	1.938	4.000	—	BS			<i>Flanged end yoke, strap kit not furnished by Dana</i> 3-4-11871-2
1.750	2.500	1.938	5.750	—	BS			<i>Attaching hardware by OEM</i> 3-4-7171
1.750	2.500	1.953	4.000	—	BS			<i>Flanged end yoke, strap kit not furnished by Dana</i> 3-4-9271-1
1.750	2.500	1.953	4.000	—	BS			3-4-9271-2
1.750	2.500	2.000	4.000	—	BS			<i>Attaching hardware by OEM</i> 3-4-13901-1
1.750	2.500	2.250	4.281	—	BS			3-4-6411-1•
1.750	2.625	1.938	3.969	—	UB			3-4-4051
1.750	2.625	2.188	4.281	—	BS	3-4-5811-1X	230909	3-4-3391-1•
1.750	2.625	2.188	4.750	—	BS			<i>250 deep spline chamfer</i> 3-4-10301-1
1.750	2.625	2.250	4.281	—	BS	3-4-5791-1X	230909	<i>Flanged yoke w/.250 deep spline chamfer</i> 3-4-3061-1
1.750	2.625	2.250	4.469	—	BS			<i>.250 deep spline chamfer</i> 3-4-3121-1
1.750	2.685	2.245	4.276	—	BS			3-4-3541-1
1.750	2.750	2.250	4.281	.500	UB			3-4-9621
1.751-27 Involute Spline								
1.751	2.500	2.063	4.125	—	BS			3-4-11181-1•
1.751	2.625	2.281	4.250	—	BS			3-4-11161-1•

• Part is discontinued ■ Part is available until supply is exhausted ▲ Not sold separately



Important: See Safety Information in General Information Section (J300P-GI)

END YOKES with SPLINED HOLES

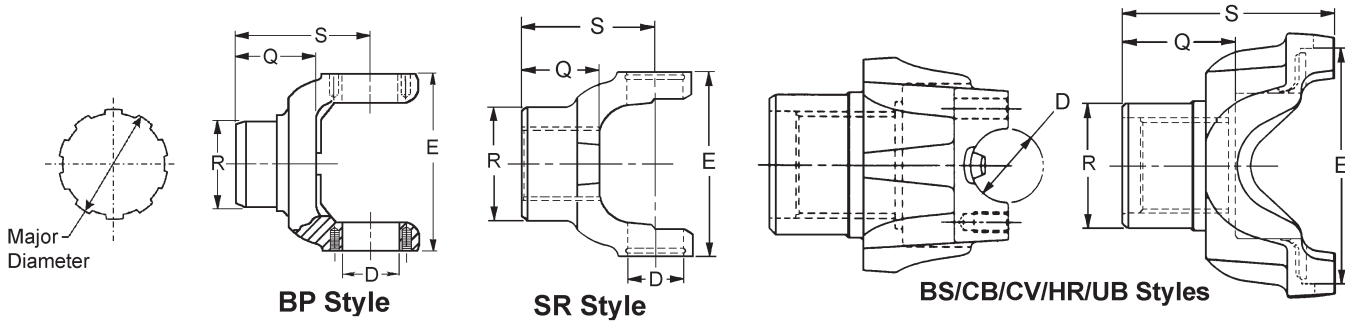

Major Diameter	R	Q	S	C'Bore Depth	Style	End Yoke Assy. (includes slinger) Order When Listed	Slinger/Plug Part Number	Spicer Part Number
	Ground Hub Dia.	Length Thru Hole	Centerline to End					
1480 SERIES (Continued) SR: E-4.438 OTHERS: E-4.188, D-1.375 USE KIT 5-188X, 5-803X								
USES U-BOLT ASSY NO.3-94-28X, STRAP ASSY. 3-70-38X								
1.751-27 Involute Spline (Continued)								
1.751	3.000	2.469	4.500	.490	BS			3-4-9981-1•
1.774-34 Spline								
1.774	2.500	2.250	4.469	—	BS	3-4-8051-1X	231206	3-4-7541-1▲
1.774	2.500	2.250	4.469	—	BS			3-4-7541-2■
<i>Attaching hardware by OEM</i>								
1.790-34 Involute Spline								
1.790	2.375	2.188	4.219	—	BS	3-4-12101-1X	232198	3-4-12091-1•
1.790	2.562	2.750	5.125	—	BS	3-4-9241-1X•	231059	3-4-9231-1•
<i>Attaching hardware by OEM</i>								
1.790	2.562	2.750	5.125	—	BS	3-4-9241-2X•	231059	3-4-9231-2•
<i>Attaching hardware by OEM</i>								
1.790	2.562	2.750	5.562	—	BS	3-4-7261-1X	231059	3-4-7251-1▲
<i>Flanged end yoke, strap kit not furnished by Dana</i>								
1.790	2.567	2.750	4.885	—	BS	3-4-11621-1X	231059	3-4-11551-1•
<i>Flanged end yoke, strap kit not furnished by Dana</i>								
1.790	2.625	2.188	4.281	—	UB	3-4-10471X•	232039	3-4-10261•
1.790	2.625	2.188	4.281	—	BS	3-4-10471-1X	232039	3-4-10261-1
1.790	2.625	2.188	4.281	—	BS	3-4-11921-1X•	231935	3-4-10261-1
1.790	2.625	2.188	4.281	—	BS			3-4-13931-1
1.875-10 Spline								
1.875	2.750	2.375	4.406	—	BS	3-4-6671-1X■	230900	3-4-3901-1▲
1.922-14 Involute Spline								
1.922	2.375	2.188	4.438	—	BS			3-4-11071-1
1.922	2.375	2.188	4.438	—	BS			3-4-7571-1
1.964-10 Spline								
1.964	2.500	2.000	4.688	—	UB			3-4-4211
1.969-10 Spline								
1.969	2.625	2.250	4.406	—	BS	3-4-5821-1X	230897	3-4-3861-1•
<i>.250 deep spline chamfer</i>								
1.972-10 Spline								
1.972	2.594	1.859	4.500	—	BS			3-4-5441-1
1.972	2.598	1.859	4.525	—	BS			3-4-3051-1
1.998-38 Involute Spline								
1.998	2.750	2.125	4.156	—	BS			3-4-8781-1
1.998	3.000	2.125	4.281	—	BS	3-4-12121-1X•	232200	3-4-12111-1•
2.008-31 Involute Spline								
2.008	2.750	2.441	4.526	.240	BS			3-4-11771-1•
2.008	2.750	3.386	5.710	—	BS			3-4-11121-1•
<i>Flanged end yoke.</i>								

• Part is discontinued

■ Part is available until supply is exhausted

▲ Not sold separately



Major Diameter	R	Q	S	C'Bore Depth	Style	End Yoke Assy. (includes slinger/plug) Order When Listed	Slinger/Plug Part Number	Spicer Part Number
	Ground Hub Dia.	Length Thru Hole	Centerline to End					
1480 SERIES (Continued) SR: E-4.438 OTHERS: E-4.188, D-1.375						USE KIT 5-188X, 5-803X		
USES U-BOLT ASSY NO.3-94-28X, STRAP ASSY. 3-70-38X								
2.024-39 Involute Spline								
2.024	2.625	2.250	4.344	—	BS	3-4-11061-1X	232039	3-4-11051-1
2.024	2.625	2.250	4.344	.250	BS	3-4-13061-1X	232167	3-4-13051-1 ▲
2.024	3.000	1.832	3.878	.250	BS	5006976	5006975	3-4-14781-1 ▲
2.024	3.000	1.832	3.878	.250	BS	3-4-14791-1X	232511	3-4-14781-1 ▲
2.024	3.000	1.832	3.878	.250	BS	3-4-14841-1X ■	233051	3-4-14781-1 ▲
2.024	3.000	2.281	4.344	.250	BS	3-4-13081-1X	232511	3-4-13071-1
2.114-32 Involute Spline								
2.114	3.000	2.250	4.281	.424	BS	3-4-13351-1X	232200	3-4-13341-1•
1550 SERIES SR:E=5.250, ALL OTHERS:E-4.964 D-1.375						USE KIT 5-155X, 5-808X		
USES U-BOLT ASSY. 3-94-28X, STRAP ASSY. 3-70-38X								
1.500-10 Spline								
1.500	2.312	2.000	3.775	—	BS			4-4-2051-1 <i>Coupling shaft yoke</i>
1.500	2.562	2.000	3.812	—	BS			4-4-4211-1 <i>Coupling shaft yoke</i>
1.500	2.562	2.000	3.812	—	BS			4-4-4211-2 <i>Coupling shaft yoke. Attaching hdwr by OEM</i>
1.506-23 Involute Spline								
1.506	2.375	1.403	4.345	—	BS			4-4-6711-1
1.605-15 Involute Spline								
1.605	2.125	1.938	4.000	—	BS			4-4-5601-1
1.605	2.125	1.953	4.000	—	BS			4-4-6331-1
1.609-37 Involute Spline								
1.609	2.500	2.016	4.406	.240	BS	4-4-6851-1X	231872	4-4-6841-1•
1.625-10 Spline								
1.625	2.375	2.125	3.938	—	BS			4-4-1921-1
1.625	2.750	1.750	3.750	—	BS			4-4-5571-1•
1.750-10 Spline								
1.750	2.375	2.188	4.000	—	BS			4-4-2041-1
1.750	2.375	2.250	4.281	—	BS			4-4-5111-1•
1.750	2.500	1.915	4.115	—	BS			4-4-6791-2 <i>Attaching hardware by OEM</i>
1.750	2.500	1.938	4.125	—	BS			4-4-4781-1
1.750	2.500	1.938	4.125	—	BS			4-4-4781-2 <i>Attaching hardware by OEM</i>
1.750	2.500	2.000	4.125	—	BS			4-4-4171-1•
1.750	2.500	2.000	5.750	—	BS	4-4-7861-1X	—	4-4-7421-1 ▲ <i>Flanged yoke w/eight 7-73-620 bolts</i>
1.750	2.500	2.250	4.188	—	BS			4-4-2511-1
1.750	2.500	2.260	4.290	—	BS			4-4-5251-1•
1.750	2.625	2.188	4.281	—	BS			4-4-3841-1•
1.750	2.625	2.234	4.672	—	BS	4-4-3581-1X	230909	4-4-1901-1 <i>.250 deep spline chamfer</i>
1.750	2.625	2.250	4.281	—	BS			4-4-2091-1
1.750	2.750	2.245	4.652	—	BS			4-4-3811-1
1.750	2.750	2.250	4.281	—	BS			4-4-1931-1
1.750	2.750	2.250	4.812	—	BS			4-4-5721-1•
1.751-27 Involute Spline								
1.751	2.500	2.094	4.125	—	BS			4-4-6141-1•
1.751	2.750	2.400	4.250	—	BS			4-4-5991-1 <i>.250 deep spline chamfer</i>

• Part is discontinued ■ Part is available until supply is exhausted ▲ Not sold separately



Important: See Safety Information in General Information Section (J300P-GI)

END YOKES with SPLINED HOLES

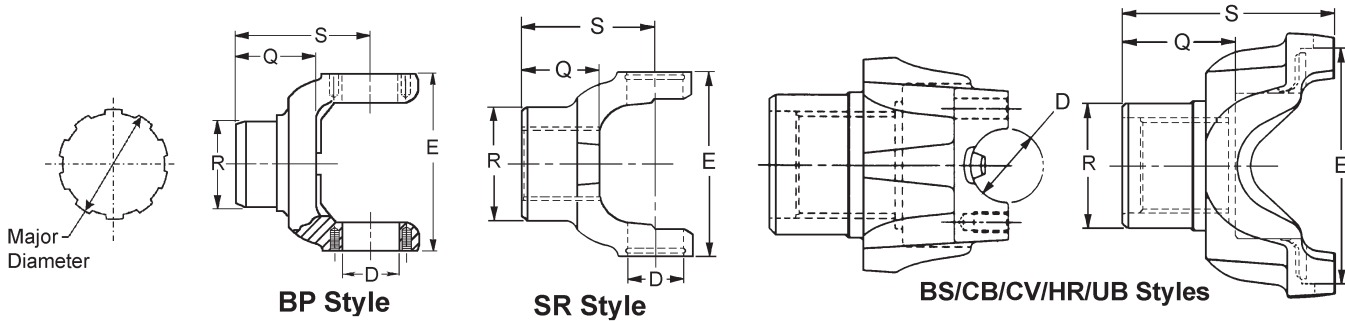

Major Diameter	R	Q	S	C'Bore Depth	Style	End Yoke Assy. (includes slinger) Order When Listed	Slinger/Plug Part Number	Spicer Part Number
	Ground Hub Dia.	Length Thru Hole	Centerline to End					
1550 SERIES (Con't) SR:E=5.250, ALL OTHERS:E=4.964 D=1.375 USE KIT 5-155X, 5-808X								
USES U-BOLT ASSY. 3-94-28X, STRAP ASSY. 3-70-38X								
1.755-13 Involute Spline								
1.755	2.375	2.250	4.031	—	BS			4-4-2931-1
1.755	2.375	2.250	4.063	—	BS	4-4-5241-1X [■]	4-68-58X	4-4-5231-1 [▲]
<i>Hub diameter not ground; Contains plug w/zerk fitting #4-68-58X</i>								
1.774-34 Spline								
1.774	2.500	2.260	4.700	—	BS	4-4-4111-1X	231206	4-4-4101-1
1.790-34 Involute Spline								
1.790	2.375	2.200	4.000	—	BS	4-4-6961-1X	232198	4-4-6951-1 [•]
1.790	2.562	2.750	5.156	—	BS	4-4-4801-1X	231059	4-4-4791-1 [•]
1.790	2.562	2.750	5.156	—	BS	4-4-4801-2X	231059	4-4-4791-2 [•]
<i>Attaching hardware by OEM</i>								
1.790	2.562	2.750	5.531	—	BS	4-4-7871-1X	231059	4-4-7431-1 [▲]
<i>Flanged end yoke</i>								
1.790	2.562	2.790	5.125	—	BS	4-4-3861-1X	231059	4-4-3851-1 [•]
1.790	2.625	2.185	4.275	—	BS	4-4-5611-1X	232039	4-4-5551-1 [•]
1.875-10 Spline								
1.875	2.750	2.375	4.406	—	UB			4-4-1941 [•]
1.875	2.750	2.375	4.406	—	BS			4-4-1941-1 [•]
1.922-14 Involute Spline								
1.922	2.375	2.203	4.641	—	BS			4-4-4811-1
1.962-10 Spline								
1.962	2.625	2.266	4.266	—	BS	4-4-4071-1X	230897	4-4-2431-1 [•]
1.962	2.625	2.266	4.266	—	BS	4-4-4071-2X [•]	230897	4-4-2431-2 [•]
<i>Attaching hardware by OEM</i>								
1.962	2.750	2.812	5.000	—	BS			4-4-4191-1
1.962	2.750	2.812	5.000	—	BS			4-4-4771-2
<i>Attaching hardware by OEM</i>								
1.962	2.750	2.812	5.000	—	BS			4-4-6781-2 [■]
<i>Attaching hardware by OEM</i>								
1.962	2.938	2.530	4.585	—	BS			4-4-5061-1
1.972-10 Spline								
1.972	2.750	2.375	4.422	—	BS			4-4-2381-1
1.998-38 Involute Spline								
1.998	2.750	1.984	4.156	—	UB			4-4-4611
1.998	2.750	1.984	4.156	—	BS			4-4-4611-1 [•]
1.998	2.750	1.984	4.156	—	BS			4-4-4611-2
<i>Attaching hardware by OEM</i>								
1.998	2.750	2.125	4.047	—	BS			4-4-4491-1
1.998	2.750	2.125	4.141	—	BS			4-4-7341-1
1.998	2.750	2.125	7.031	—	BS			4-4-6101-1
<i>Flanged end yoke.</i>								
1.998	3.000	2.125	4.500	—	BS	4-4-6981-1X	232200	4-4-6971-1 [•]

• Part is discontinued

■ Part is available until supply is exhausted

▲ Not sold separately



END YOKES with SPLINED HOLES



Major Diameter	R	Q	S	C'Bore Depth	Style	End Yoke Assy. (includes slinger/plug) Order When Listed	Slinger/Plug Part Number	Spicer Part Number
	Ground Hub Dia.	Length Thru Hole	Centerline to End					
1550 SERIES (Con't) SR:E=5.250, ALL OTHERS:E-4.964 D-1.375 USE KIT 5-155X, 5-808X								
USES U-BOLT ASSY. 3-94-28X, STRAP ASSY. 3-70-38X								
2.000-10 Spline								
2.000	2.484	2.453	4.500	—	BS			4-4-2451-1
2.000	2.625	2.125	4.203	—	BS			4-4-2401-1
2.000	2.625	2.250	4.281	.384	BS			4-4-6211-1•
2.000	2.750	2.000	4.406	—	BS			4-4-2481-1
2.000	2.750	3.000	5.063	—	UB			4-4-2941•
2.000	3.031	3.000	5.125	—	BS	4-4-5171-1X•	231620	4-4-5161-1▲ <i>Flanged end yoke w/notched slinger for magnetic pick-up.</i>
2.005-15 Involute Spline								
2.005	2.875	2.680	4.655	.620	BS			4-4-4421-1
2.008-31 Involute Spline								
2.008	2.375	1.406	3.188	—	BS			4-4-4371-1•
2.008	2.625	2.297	4.165	.380	BS	4-4-5941-1X	232189	4-4-5841-1▲
2.008	2.750	3.386	6.078	—	BS			4-4-6641-1• <i>Flanged end yoke.</i>
2.008	3.000	2.766	4.938	.490	BS			4-4-5091-1
2.024-39 Involute Spline								
2.024	2.625	2.250	4.266	.250	BS	4-4-7551-1X	232167	4-4-6471-1▲
2.024	2.625	2.255	4.281	—	BS	4-4-5691-1X	232039	4-4-5621-1•
2.024	3.000	2.297	4.281	.250	BS	4-4-7571-1X	232511	4-4-7561-1▲
2.024	3.000	2.312	5.000	—	BS	4-4-6731-1X•	231359	4-4-5261-1
2.070-32 Involute Spline								
2.070	2.875	2.781	2.875	—	BS	4-4-7251-1X	4-68-94	4-4-7241-1•
2.114-32 Involute Spline								
2.114	3.000	2.250	4.312	.424	BS	4-4-7001-1X	232200	4-4-6991-1•
2.125-16 Involute Spline								
2.125	3.000	3.047	5.094	—	BS			4-4-4361-1
2.143-41 Involute Spline								
2.143	2.938	2.500	4.500	—	BS	4-4-5701-1X•	231028	4-4-5581-1•
2.250-10 Spline								
2.250	3.000	3.000	5.047	—	BS			4-4-3931-2 <i>Attaching hardware by OEM</i>
2.250	3.500	3.000	5.125	—	BS			4-4-3501-1
2.364-18 Involute Spline								
2.364	3.000	2.765	4.777	—	BS			4-4-2531-1•
2.364-36 Involute Spline								
2.364	3.000	2.688	5.078	—	BS	4-4-7111-1X	232200	4-4-7011-1•
2.372-46 Involute Spline								
2.372	3.000	3.375	5.500	.787	BS	4-4-4451-1X	232189	4-4-4381-1▲
2.372	3.020	3.734	6.193	.790	BS			4-4-7211-1M <i>Flanged yoke; Flange has 8 threaded metric holes.</i>

• Part is discontinued ■ Part is available until supply is exhausted ▲ Not sold separately



Important: See Safety Information in General Information Section (J300P-GI)

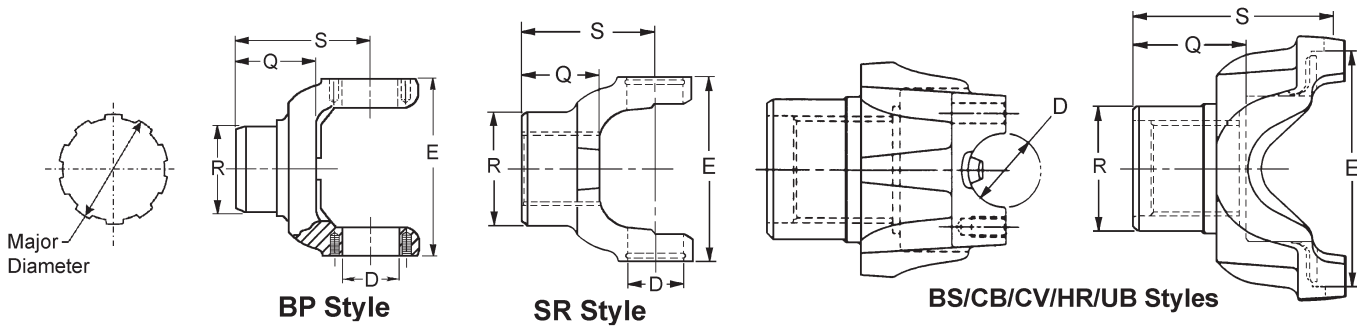

Major Diameter	R	Q	S	C'Bore Depth	Style	End Yoke Assy. (includes slinger/plug) Order When Listed	Slinger/Plug Part Number	Spicer Part Number
	Ground Hub Dia.	Length Thru Hole	Centerline to End					
1610 SERIES			E-5.312	D-1.875	USE KIT 5-279X, 5-674X			

FOR HR STYLE USE STRAP KIT 5-70-28X
1.618-18 Involute Spline

1.618	2.200	2.160	4.125	—	BP			5-4-8041
-------	-------	-------	-------	---	----	--	--	----------

1.625-10 Spline

1.625	2.375	2.125	4.125	—	BP			5-4-2401
1.625	2.375	2.185	4.190	—	BP			5-4-9741•

Four slots across end of hub
1.750-10 Spline

1.750	2.188	2.250	4.125	.500	BP			5-4-1721
1.750	2.188	2.250	4.125	.500	HR	<i>Forge version does not have counterbore; Coupling shaft yoke</i>		
								5-4-1721-1
								<i>Coupling shaft yoke</i>
1.750	2.375	2.250	4.906	.250	HR			5-4-6941-1
1.750	2.484	3.000	5.000	—	BP			5-4-871•
1.750	2.500	1.938	4.125	—	BP			5-4-5711
1.750	2.500	1.953	4.125	—	HR			5-4-7631-1•
1.750	2.500	2.188	4.875	—	HR			5-4-7031-1•
1.750	2.500	2.250	4.125	.250	BP			5-4-1051
1.750	2.500	2.250	4.720	—	HR			5-4-7581-1•
1.750	2.625	2.250	4.125	—	BP			5-4-781
1.750	2.625	2.250	4.750	.250	BP	5-4-5111X	230909	5-4-2081
1.750	2.625	2.250	4.750	.250	HR	5-4-5111-1X	230909	5-4-2081-1•
1.750	2.625	2.250	5.062	.250	BP			5-4-2521•
1.750	2.625	2.250	5.344	—	BP			5-4-4461
1.750	2.625	2.250	5.344	—	HR			5-4-4461-1•
1.750	2.625	2.250	5.344	—	BP			5-4-4571
1.750	2.625	2.250	6.000	.250	BP	5-4-4761X	230909	5-4-3901•
								<i>High angle yoke</i>
1.750	2.750	2.250	4.750	—	BP	5-4-3601X	230794	5-4-1931•
1.750	2.750	2.250	5.000	—	BP			5-4-3621
1.750	2.750	2.250	6.000	—	BP	5-4-4441X•	230794	5-4-3861■
								<i>High angle yoke</i>

1.750-27 Involute Spline

1.750	2.125	1.891	4.750	—	HR			5-4-6981-1•
-------	-------	-------	-------	---	----	--	--	-------------

1.774-34 Spline

1.774	2.500	2.250	4.875	—	HR	5-4-5621-1X	231206	5-4-5571-1
1.774	2.500	2.250	5.438	.120	BP	5-4-5081X	231101	5-4-6261■
1.774	2.500	2.250	5.438	.120	HR			5-4-6261-1
1.774	2.500	2.250	6.062	.120	BP	5-4-4901X•	231101	5-4-6251■
								<i>High angle yoke</i>

• Part is discontinued

■ Part is available until supply is exhausted

▲ Not sold separately



END YOKES with SPLINED HOLES



Major Diameter	R	Q	S	C'Bore Depth	Style	End Yoke Assy. (includes slinger/plug) Order When Listed	Slinger/Plug Part Number	Spicer Part Number
	Ground Hub Dia.	Length Thru Hole	Centerline to End					
1610 SERIES (Continued) E-5.312 D-1.875						USE KIT 5-279X, 5-674X		
FOR HR STYLE USE STRAP KIT 5-70-28X								
1.790-34 Involute Spline								
1.790	2.188	2.250	4.125	.500	HR			5-4-7171-1 <i>Coupling shaft yoke</i>
1.790	2.375	2.203	4.125	—	HR	5-4-8571-1X	232198	5-4-8561-1 ▲
1.790	2.500	2.250	5.438	—	HR			5-4-8911-1
1.790	2.562	2.750	5.312	—	BP	5-4-4841X	231059	5-4-4831•
1.790	2.562	2.750	5.312	—	HR	5-4-4841-1X	231059	5-4-4831-1•
1.790	2.562	2.750	5.312	—	HR	5-4-8061-1X	231059	5-4-7781-1•
1.790	2.567	2.830	5.310	—	BP	5-4-5231X•	231059	5-4-5221•
1.790	2.625	2.188	4.750	—	BP			5-4-7261•
1.790	2.625	2.188	4.750	—	HR	5-4-7301-1X	232039	5-4-7261-1■
1.790	2.625	2.188	5.880	—	HR			5-4-7941-1•
1.790	2.625	2.422	4.938	.250	HR	5-4-8501-1X	232166	5-4-8491-1•
1.790	2.625	2.438	4.938	—	BP			5-4-6341
1.790	2.625	2.438	6.188	—	BP			5-4-6351 <i>High angle yoke</i>
1.790	2.625	2.438	6.188	.250	BP	5-4-8441X	232166	5-4-8001• <i>High angle yoke</i>
1.875-10 Spline								
1.875	2.750	2.000	4.469	—	HR			5-4-7701-1■
1.875	2.750	2.375	5.000	—	BP			5-4-2501•
1.939-30 Involute Spline								
1.939	3.000	2.250	4.750	—	BP			5-4-4391
1.960-10 Spline								
1.960	2.438	3.000	5.500	—	BP			5-4-4721• <i>Coupling shaft yoke</i>
1.960	2.750	2.625	5.125	—	BP	5-4-5281X	98-1362	5-4-3681•
1.960-6 Spline								
1.960	2.750	3.000	5.000	—	BP	5-4-2031X	330287	5-4-1431•
1.962-10 Spline								
1.962	2.500	2.000	4.500	—	BP			5-4-2541•
1.962	2.625	2.250	4.719	.250	BP	5-4-5121X	230909	5-4-1641•
1.962	2.625	2.250	4.719	.250	HR	5-4-5121-1X•	230909	5-4-1641-1 ▲
1.962	2.625	2.250	4.906	—	HR			5-4-7111-1•
1.962	2.625	2.250	5.062	.250	BP			5-4-3241
1.962	2.625	2.250	5.312	—	HR	5-4-6361-1X	230909	5-4-4471-1•
1.962	2.625	2.250	5.312	.250	HR	5-4-8901-1X	230909	5-4-8851-1 <i>Chamfered Counterbore</i>
1.962	2.625	2.250	6.000	.250	BP	5-4-4771X	230909	5-4-3911• <i>High angle yoke</i>
1.962	2.750	2.625	5.938	—	BP	5-4-5321X	98-1362	5-4-4221•
1.962	2.750	2.812	5.281	—	HR			5-4-7041-1
1.962	2.750	2.812	5.281	—	HR			5-4-8361-1
1.962	2.940	2.570	5.120	.310	HR			5-4-9511-1
1.962	3.000	2.250	4.750	—	BP			5-4-2531 <i>Chamfered Counterbore</i>
1.962	3.000	2.250	5.375	—	BP			5-4-4541
1.964-10 Spline								
1.964	2.500	2.000	5.219	—	BP			5-4-4551
1.964	2.750	2.812	5.000	—	BP			5-4-5091
1.989-30 Involute Spline								
1.989	3.000	2.688	6.000	.220	BP	5-4-7251X	231750	5-4-5721
1.989	3.000	2.688	6.000	.220	HR	5-4-8671-1X	232199	5-4-8661-1• <i>High angle yoke</i>

• Part is discontinued ■ Part is available until supply is exhausted ▲ Not sold separately



Important: See Safety Information in General Information Section (J300P-GI)

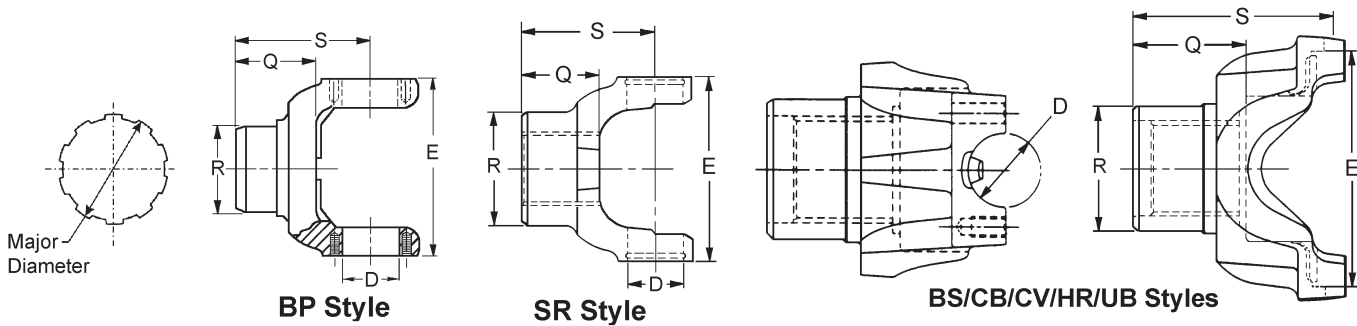

Major Diameter	R	Q	S	C'Bore Depth	Style	End Yoke Assy. (includes slinger/plug) Order When Listed	Slinger/Plug Part Number	Spicer Part Number
	Ground Hub Dia.	Length Thru Hole	Centerline to End					

1610 SERIES (Continued) E-5.312 D-1.875
USE KIT 5-279X, 5-674X
FOR HR STYLE USE STRAP KIT 5-70-28X
1.998-38 Involute Spline

1.998	2.750	1.969	4.156	—	BP			5-4-6481•
1.998	2.750	1.969	4.156	—	HR			5-4-6481-1
1.998	2.750	2.125	4.000	—	HR			5-4-6321-1
1.998	2.750	2.125	4.000	—	HR			5-4-8971-1
1.998	2.750	2.125	4.125	—	BP			5-4-6321
1.998	2.750	2.125	7.562	—	HR			5-4-7601-1 <i>Flanged end yoke.</i>
1.998	3.000	2.125	4.844	—	BP	5-4-7121X	231750	5-4-6131■
1.998	3.000	2.125	4.844	—	BP	5-4-5861X	231347	5-4-6131■
1.998	3.000	2.125	4.844	—	HR	5-4-8591-1X	232200	5-4-8581-1•

2.000-10 Spline

2.000	2.750	2.000	4.688	—	BP			5-4-1831
2.000	2.750	2.000	4.688	—	HR			5-4-7061-1
2.000	2.750	2.469	5.781	.125	BP			5-4-4381•
2.000	2.750	3.000	5.188	—	BP			5-4-1661
2.000	2.750	3.000	5.469	—	HR			5-4-1661-1
2.000	2.938	2.562	5.188	—	BP	5-4-5131X	98-1361	5-4-1631•
2.000	2.938	3.000	5.000	—	BP			5-4-1221■
2.000	2.938	3.000	5.000	—	BP			5-4-1521
2.000	2.938	3.000	5.625	—	BP			5-4-1391
2.000	3.031	3.000	5.609	—	HR	5-4-7101-1X•	231620	5-4-6541-1• <i>Flanged end yoke w/notched slinger for magnetic pick-up.</i>

2.008-31 Involute Spline

2.008	—	2.031	4.953	—	HR			5-4-8961-1 <i>Hub diameter not ground.</i>
2.008	2.625	2.312	3.969	—	HR	5-4-7691-1X•	232189	5-4-7481-1•

2.024-39 Spline

2.024	2.750	2.000	4.500	—	BP			5-4-5881
2.024	2.750	2.438	5.938	.120	BP	5-4-6961X	231599	5-4-5441• <i>High angle yoke</i>
2.024	2.750	2.438	6.250	.120	BP	5-4-6871X•	231599	5-4-5461 <i>High angle yoke</i>
2.024	2.750	2.438	6.250	.120	BP			5-4-5461 <i>High angle yoke</i>
2.024	2.750	2.453	5.125	—	BP	5-4-6951X	231599	5-4-5421•
2.024	3.000	2.312	4.875	—	BP	5-4-6431X	231102	5-4-6421•
2.024	3.000	2.312	4.875	—	HR	5-4-6431-1X	231102	5-4-6421-1•
2.024	3.000	2.312	4.875	—	HR	5-4-6441-1X	231359	5-4-6421-1•
2.024	3.000	2.312	5.531	.090	BP	5-4-6281X	231359	5-4-6271■

• Part is discontinued

■ Part is available until supply is exhausted

▲ Not sold separately



END YOKES with SPLINED HOLES



Major Diameter	R	Q	S	C'Bore Depth	Style	End Yoke Assy. (includes slinger/plug) Order When Listed	Slinger/Plug Part Number	Spicer Part Number	
	Ground Hub Dia.	Length Thru Hole	Centerline to End						
1610 SERIES (Continued) E-5.312 D-1.875							USE KIT 5-279X, 5-674X		
FOR HR STYLE USE STRAP KIT 5-70-28X									
2.024-39 Spline (Continued)									
2.024	3.000	2.312	6.219	.090	BP	5-4-6291X	231359	5-4-6241 <i>High angle yoke</i>	
2.024	3.000	2.312	6.219	.090	HR	5-4-6291-1X	231359	5-4-6241-1• <i>High angle yoke</i>	
2.024-39 Involute Spline									
2.024	2.625	2.234	4.719	—	HR	5-4-8131-1X	232039	5-4-7981-1▲	
2.024	2.625	2.250	4.910	.250	HR	5-4-9441-1X	232167	5-4-9431-1•	
2.024	2.625	2.250	5.312	—	BP	5-4-5991X	230909	5-4-5981■	
2.024	2.625	2.250	5.312	.250	BP	5-4-8411X	232167	5-4-7971•	
2.024	2.625	2.250	5.312	.250	HR	5-4-8411-1X	232167	5-4-7971-1•	
2.024	2.625	2.250	6.000	—	BP	5-4-5971X	230909	5-4-5961 <i>High angle yoke</i>	
2.024	2.625	2.250	6.000	.250	BP	5-4-8421X	232167	5-4-7991• <i>High angle yoke</i>	
2.024	2.625	2.500	6.000	.250	BP	5-4-9271X•	232514	5-4-8301• <i>High angle yoke</i>	
2.024	3.000	2.250	6.000	.280	HR	5-4-9311-1X	232200	5-4-9291-1• <i>High angle yoke</i>	
2.024	3.000	2.281	4.875	.250	HR	5-4-9231-1X	232511	5-4-9221-1▲	
2.024	3.000	2.281	6.000	.250	HR	5-4-9241-1X	232511	5-4-8261-1• <i>High angle yoke</i>	
2.024	3.000	2.281	6.000	.250	BP	5-4-9241X■	232511	5-4-8261 <i>High angle yoke</i>	
2.024	3.000	2.500	5.594	.280	HR			5-4-9351-1	
2.032-10 Spline									
2.032	2.750	2.000	4.500	.120	BP			5-4-4401	
2.114-32 Involute Spline									
2.114	3.000	2.234	5.375	.424	HR	5-4-8611-1X	232200	5-4-8601-1	
2.114	3.000	2.234	6.000	.424	HR	5-4-8691-1X	232200	5-4-8681-1 <i>High angle yoke</i>	
2.114	3.000	2.250	5.375	.424	BP	5-4-7221X	231750	5-4-5751	
2.114	3.000	2.250	6.000	.424	BP	5-4-7181X	231750	5-4-5731	
2.143-41 Involute Spline									
2.143	2.938	2.500	5.250	—	HR	5-4-7311-1X	231028	5-4-7271-1•	
2.143	2.938	2.500	5.250	—	HR	5-4-9111-1X	232604	5-4-7271-1•	
2.143	2.938	2.500	6.000	—	BP	5-4-9121X•	232604	5-4-7561•	
2.143	2.938	2.500	6.000	—	BP	5-4-7571X	231028	5-4-7561•	
2.143	2.938	2.500	6.000	—	HR	5-4-9121-1X•	232604	5-4-7561-1•	
2.143	2.938	2.500	6.000	—	HR	5-4-7571-1X•	231028	5-4-7561-1•	
2.143	2.938	3.000	6.500	.380	HR	5-4-9131-1X•	232609	5-4-7551-1•	
2.143	2.939	2.500	5.660	—	HR	5-4-9451-1X	232604	5-4-9421-1▲	
2.143	3.000	2.188	4.680	.310	HR	5002873	5002871	5002872▲	
2.149-16 Spline									
2.149	2.938	3.000	5.660	.380	BP	5-4-6591-1X	231028	5-4-6581-1▲	
2.149	2.938	3.000	6.250	.380	BP	5-4-5161X	231028	5-4-5031• <i>High angle yoke</i>	
2.149	2.938	3.000	6.250	.380	HR	5-4-5161-1X	231028	5-4-5031-1•	
2.149	2.938	3.000	6.500	.380	BP	5-4-5511X	231028	5-4-5501• <i>High angle yoke</i>	
2.149	2.938	3.000	6.500	.380	BP	5-4-8711X	232367	5-4-5501• <i>High angle yoke</i>	

• Part is discontinued ■ Part is available until supply is exhausted ▲ Not sold separately



Important: See Safety Information in General Information Section (J300P-GI)

END YOKES with SPLINED HOLES

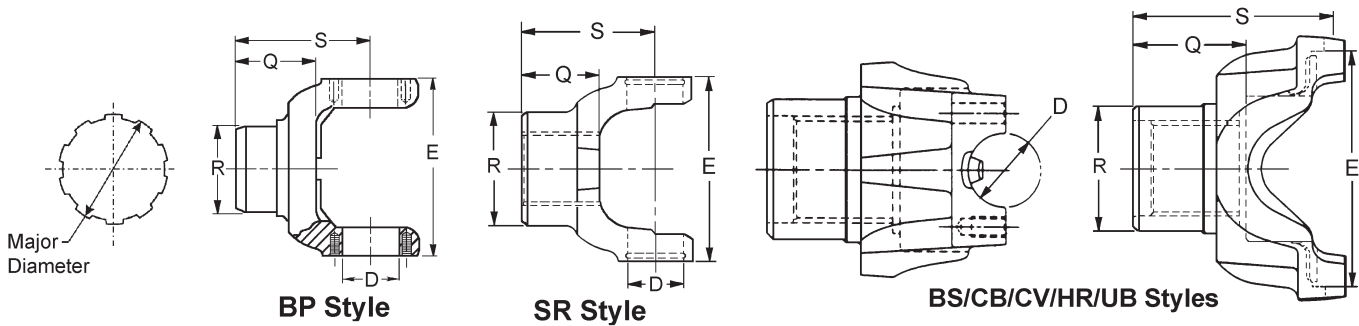

Major Diameter	R	Q	S	C'Bore Depth	Style	End Yoke Assy. (includes slinger/plug) Order When Listed	Slinger/Plug Part Number	Spicer Part Number
	Ground Hub Dia.	Length Thru Hole	Centerline to End					

1610 SERIES (Continued) E-5.312 D-1.875 USE KIT 5-279X, 5-674X

FOR HR STYLE USE STRAP KIT 5-70-28X

2.178-43 Involute Spline

2.178	3.531	2.031	5.406	.157	BP			5-4-9141
2.178	3.531	2.031	5.406	.157	HR			5-4-9141-1
2.178	3.547	2.047	5.219	.157	HR			5-4-8461-1•

2.195-34 Involute Spline

2.195	3.543	1.889	4.441	—	HR			5008270 [▲] OEM only
-------	-------	-------	-------	---	----	--	--	----------------------------------

2.225-6 Spline

2.225	3.000	3.250	5.719	—	BP	5-4-4751X	829W	5-4-4741 [▲]
-------	-------	-------	-------	---	----	-----------	------	-----------------------

2.250-10 Spline

2.250	3.000	3.000	5.625	.250	BP	5-4-6891X	230921	5-4-3141•
2.250	3.500	3.000	5.750	—	BP			5-4-4961
2.250	3.500	3.000	5.750	—	HR			5-4-4961-1■
2.250	3.750	3.000	5.750	—	HR	5-4-7391-1X	231616	5-4-7381-1•

2.260-6 Spline

2.260	3.250	2.250	4.938	—	BP			5-4-1891
2.260	3.250	2.250	4.938	—	HR	5-4-8211-1X	232042-6	5-4-1891-1•

2.274-44 Involute Spline

2.274	2.938	2.328	4.844	—	HR	5-4-9101-1X	232604	5-4-8021-1•
2.274	2.938	2.328	4.844	—	HR	5-4-8031-1X	231022	5-4-8021-1•
2.274	2.938	2.500	5.000	—	BP	5-4-6381X•	231022	5-4-6371•
2.274	2.938	2.500	5.000	—	HR	5-4-6381-1X	231022	5-4-6371-1•
2.274	2.938	2.500	5.000	—	HR	5-4-8431-1X	232168	5-4-8321-1 [▲]
2.274	3.000	2.500	5.000	.236	BP	5-4-9261-1X•	232511	5-4-8311-1•

2.320-36 Involute Spline

2.320	3.000	3.040	5.420	—	HR	5004358 [▲]		5004159
-------	-------	-------	-------	---	----	----------------------	--	---------

OEM only; Assy includes o-ring 232849, welch plug 6-68-134 & snap ring

2.343-45 Involute Spline

2.343	3.750	3.000	5.750	—	HR	5-4-7651-1X•	231616	5-4-7641-1•
-------	-------	-------	-------	---	----	--------------	--------	-------------

2.364-36 Involute Spline

2.364	3.000	2.688	5.156	—	BP	5-4-7201X	231750	5-4-5631■
2.364	3.000	2.688	5.156	—	BP	5-4-7211X•	231755	5-4-7191 [▲]
2.364	3.000	2.688	5.156	—	HR	5-4-8631-1X	232200	5-4-8621-1•
2.364	3.000	2.688	5.156	—	HR	5-4-8651-1X	231755	5-4-8641-1•
2.364	3.000	2.703	6.000	—	BP	5-4-7231X	231750	5-4-5741•

2.372-46 Involute Spline

2.372	2.938	3.375	6.234	.500	HR			5-4-6521-1 Flanged end yoke
2.372	3.000	3.000	4.547	.120	HR	5-4-7441-1X	500166-46	5-4-7431-1 [▲]

• Part is discontinued

■ Part is available until supply is exhausted

▲ Not sold separately



END YOKES with SPLINED HOLES



Major Diameter	R	Q	S	C'Bore Depth	Style	End Yoke Assy. (includes slinger/plug) Order When Listed	Slinger/Plug Part Number	Spicer Part Number
	Ground Hub Dia.	Length Thru Hole	Centerline to End					
1610 SERIES (Continued) E-5.312 D-1.875						USE KIT 5-279X, 5-674X		
FOR HR STYLE USE STRAP KIT 5-70-28X								
2.372-46 Involute Spline (Continued)								
2.372	3.000	3.165	5.890	—	HR			5-4-9191-1M <i>Metric bolt holes</i>
2.372	3.000	3.391	5.740	.500	HR			5-4-6161-1•
2.372	3.000	3.500	5.891	.500	HR	5-4-6151-1X•	500166-46	5-4-6141-1•
2.372	3.000	3.550	5.890	—	HR	5-4-9631-1X	232638	5-4-9621-1▲
2.374-46 Spline								
2.374	3.250	2.312	4.940	—	HR	5-4-9541-1X	232746	5-4-9581-1▲
2.374	3.250	2.891	4.547	—	HR	5-4-7361-1X•	231615	5-4-7351-1▲
2.387-18 Involute Spline								
2.387	3.000	2.891	5.203	—	HR			5-4-5851-1
2.387	3.000	3.094	4.562	.120	HR	5-4-6101-1X•	500166-46	5-4-5831-1•
2.390-46 Involute Spline								
2.390	3.250	2.312	4.938	.140	HR	5-4-7341-1X	231803	5-4-7331-1•
2.390	3.500	3.391	6.125	—	BP			5-4-4861
2.390	3.500	3.391	6.125	—	HR			5-4-4861-1
2.422-18 Involute Spline								
2.422	3.250	2.500	5.260	—	HR			5-4-9571-1
2.422	3.375	3.000	6.125	.380	HR	5-4-5491-1X•	231013	5-4-5361-1•
2.500-10 Spline								
2.500	3.250	3.000	5.688	—	HR	5-4-8351-1X	231179	5-4-8341-1•
2.500	3.750	3.000	6.125	—	BP			5-4-4971 <i>Hub machined for speedometer gear</i>
2.547-49 Involute Spline								
2.547	4.000	2.750	5.500	.560	HR			5-4-7951-1•
2.588-40 Involute Spline								
2.588	3.625	2.640	5.280	—	HR	5004899▲	5001780	5004898▲ <i>OEM only</i>
2.625-20 Involute Spline								
2.625	3.750	2.750	5.062	—	HR			5-4-6531-1• <i>Hub machined for speedometer gear</i>
1650 SERIES E-5.594 D-1.625						USE KIT 5-165X		
USES CAP & BOLT ASSY. 5-70-18X								
1.750-10 Spline								
1.750	2.625	2.250	4.375	.250	CB	5-4-4161X•	230909	5-4-2141• <i>Chamfered Counterbore</i>
2.000-10 Spline								
2.000	2.625	2.125	4.375	—	CB			5-4-2331
2.000-15 Involute Spline								
2.000	3.000	3.250	5.406	.105	CB			5-4-4701■
2.359-18 Involute Spline								
2.359	2.875	2.688	5.281	.460	CB			5-4-5821•
2.359	3.000	2.781	5.219	.432	CB			5-4-2341•
1710 SERIES E-6.094 (6.190 FOR HR STYLE) D-1.938						USE KIT 5-280X, & 5-675X		
FOR HR STYLE USE STRAP KIT 6.5-70-18X								
1.625-10 Spline								
1.625	2.375	2.125	4.750	—	HR			6-4-7751-1•
1.750-10 Spline								
1.750	2.625	2.250	4.500	.250	BP	6-4-5581X■	230909	6-4-2081• <i>Chamfered Counterbore</i>
1.750	2.625	2.250	4.500	.250	HR	6-4-5581-1X•	230909	6-4-2081-1▲ <i>Chamfered Counterbore</i>

• Part is discontinued ■ Part is available until supply is exhausted ▲ Not sold separately



Important: See Safety Information in General Information Section (J300P-GI)

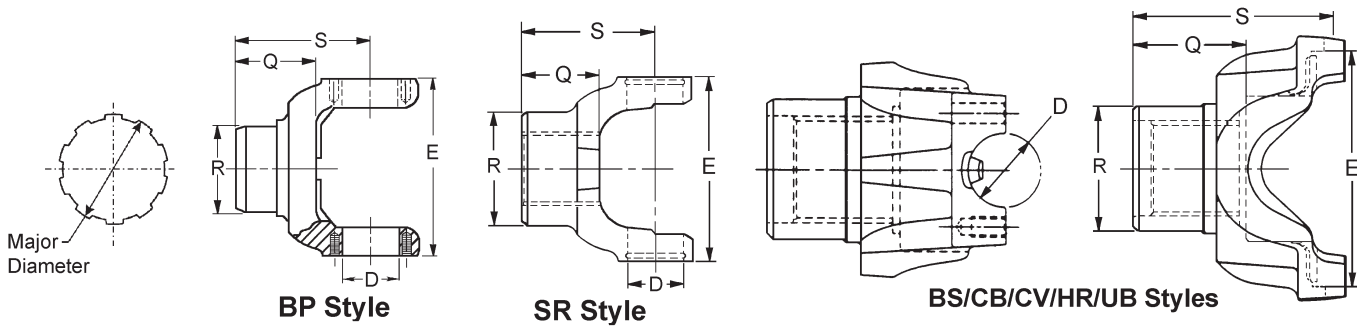

Major Diameter	R	Q	S	C'Bore Depth	Style	End Yoke Assy. (includes slinger/plug) Order When Listed	Slinger/Plug Part Number	Spicer Part Number
	Ground Hub Dia.	Length Thru Hole	Centerline to End					

1710 SERIES (Continued) E-6.094 (6.190 FOR HR STYLE) D-1.938 USE KIT 5-280X, & 5-675X

FOR HR STYLE USE STRAP KIT 6.5-70-18X

1.750-10 Spline (Continued)

1.750	2.625	2.250	5.250	.250	BP	6-4-4301X	230909	6-4-3391• <i>Chamfered Counterbore</i>
1.750	2.625	2.250	6.125	.250	BP	6-4-4861X	230909	6-4-4141■ <i>Chamfered Counterbore; High angle yoke</i>
1.750	2.750	2.250	4.875	.060	BP			6-4-2381

1.774-34 Spline

1.774	2.500	2.250	4.875	.090	BP	6-4-5131X	231101	6-4-6331
1.774	2.500	2.250	4.875	.090	HR	6-4-5131-1X	231101	6-4-6331-1■
1.774	2.500	2.250	5.969	.090	BP	6-4-5111X	231101	6-4-6321 <i>High angle yoke</i>
1.774	2.500	2.250	5.969	.090	HR			6-4-6321-1 <i>High angle yoke</i>

1.775-16 Involute Spline

1.775	2.375	2.000	4.750	.190	BP			6-4-4271
-------	-------	-------	-------	------	----	--	--	----------

1.790-34 Involute Spline

1.790	2.500	2.250	4.875	.090	HR			6-4-9021-1
1.790	2.562	2.750	5.594	—	HR	6-4-5041-1X	231059	6-4-5031-1■
1.790	2.562	2.750	7.188	—	BP	6-4-5041X	231059	6-4-5031• <i>High angle yoke</i>
1.790	2.625	2.188	5.438	—	HR	6-4-7581-1X	232039	6-4-7571-1
1.790	2.625	2.438	5.438	.250	BP			6-4-6481
1.790	2.625	2.438	5.438	.250	BP	6-4-8511X	232166	6-4-8081
1.790	2.625	2.438	5.438	.250	HR	6-4-8511-1X	232166	6-4-8081-1■
1.790	2.625	2.438	6.312	.250	BP			6-4-6451 <i>High angle yoke</i>
1.790	2.625	2.438	6.312	.250	HR			6-4-6451-1 <i>High angle yoke</i>
1.790	2.625	2.438	6.312	.250	BP	6-4-8521X	232166	6-4-8001 <i>High angle yoke</i>
1.790	2.625	2.438	6.312	.250	HR	6-4-8521-1X	232166	6-4-8001-1▲ <i>High angle yoke</i>

1.939-30 Involute Spline

1.939	3.000	2.250	4.562	—	BP			6-4-4371
-------	-------	-------	-------	---	----	--	--	----------

1.960-10 Spline

1.960	2.625	2.000	5.000	—	BP			6-4-2391
1.960	2.750	2.625	5.250	—	BP	6-4-4361X	231541	6-4-3221•
1.960	2.750	2.625	6.500	—	BP	6-4-4481X	98-1362	6-4-4131■ <i>High angle yoke</i>
1.960	2.812	3.000	5.000	—	BP			6-4-1981 <i>Coupling shaft yoke</i>

• Part is discontinued

■ Part is available until supply is exhausted

▲ Not sold separately



Major Diameter	R	Q	S	C'Bore Depth	Style	End Yoke Assy. (includes slinger/plug) Order When Listed	Slinger/Plug Part Number	Spicer Part Number
	Ground Hub Dia.	Length Thru Hole	Centerline to End					
1710 SERIES (Continued) E-6.094 (6.190 FOR HR STYLE) D-1.938 USE KIT 5-280X, & 5-675X								
FOR HR STYLE USE STRAP KIT 6.5-70-18X								
1.960-10 Spline (Continued)								
1.960	2.812	3.000	5.000	.500	HR			6-4-1981-1 <i>Coupling shaft yoke</i>
1.960	2.938	2.219	4.500	.094	BP			6-4-2061
1.962-10 Spline								
1.962	2.500	2.000	6.000	—	BP			6-4-4261 <i>High angle yoke</i>
1.962	2.625	2.250	4.500	.250	BP	6-4-4731X▪	230998	6-4-4721• <i>Chamfered Counterbore</i>
1.962	2.625	2.250	4.500	.250	HR	6-4-4731-1X	230998	6-4-4721-1• <i>Chamfered counterbore</i>
1.962	2.625	2.250	5.250	—	BP	6-4-5151X	230909	6-4-5141•
1.962	2.625	2.250	6.125	.250	BP	6-4-4851X	230909	6-4-4151• <i>High angle yoke</i>
1.962	2.625	2.250	6.125	.250	HR	6-4-4851-1X•	230909	6-4-4151-1• <i>High angle yoke</i>
1.962	2.750	2.812	5.156	—	BP			6-4-3831
1.962	2.750	2.812	5.156	—	HR			6-4-3831-1
1.964-10 Spline								
1.964	2.625	2.250	4.500	.250	BP			6-4-2211 <i>Chamfered counterbore</i>
1.964	2.750	2.750	5.250	—	BP			6-4-3901
1.964	3.000	2.250	4.562	—	BP			6-4-3291
1.989-30 Involute Spline								
1.989	3.000	2.700	6.280	.220	BP	6-4-7231X	231750	6-4-5781• <i>High angle yoke</i>
1.989	3.000	2.703	6.281	.220	HR	6-4-8741-1X	232199	6-4-8731-1 <i>High angle yoke</i>
1.998-38 Involute Spline								
1.998	2.750	2.125	5.250	—	BP			6-4-7301
1.998	2.750	2.125	5.250	—	HR			6-4-7301-1
1.998	2.810	3.000	5.000	.500	BP			6-4-7141 <i>Coupling shaft yoke</i>
1.998	2.810	3.000	5.000	.500	HR			6-4-7141-1 <i>Coupling shaft yoke</i>
1.998	3.000	2.125	4.840	.425	HR	6-4-9961-1X	232948	6-4-9951-1▲
1.998	3.000	2.125	4.844	—	BP	6-4-7291X	231751	6-4-6201•
1.998	3.000	2.125	4.844	—	HR	6-4-8661-1X	232200	6-4-8651-1▲
2.000-10 Spline								
2.000	2.750	2.000	5.000	—	BP			6-4-2371
2.000	2.750	2.562	5.188	—	BP	6-4-4391X	230794	6-4-3271▲
2.000	2.750	3.000	5.250	—	BP			6-4-2361
2.000	2.750	3.000	5.250	—	BS			6-4-2361-1▪
2.000	2.938	2.562	5.188	—	BP	6-4-4291X	98-1361	6-4-3241
2.000	2.938	2.562	5.188	—	BP	6-4-4741X	231015	6-4-3241
2.000	2.938	3.000	5.625	—	BP			6-4-2191
2.000	2.938	3.000	5.625	—	HR	6-4-7741-1X•	98-1361	6-4-2191-1•
2.000	3.250	3.000	5.625	—	BP			6-4-2001
2.000-15 Involute Spline								
2.000	3.250	2.375	4.250	—	BP			6-4-3131 <i>Tapered spline.</i>
2.000	3.250	2.688	4.562	.690	BP			6-4-5291
2.002-15 Spline								
2.002	2.625	2.375	4.250	—	BP			6-4-4871

• Part is discontinued ■ Part is available until supply is exhausted ▲ Not sold separately



Important: See Safety Information in General Information Section (J300P-GI)

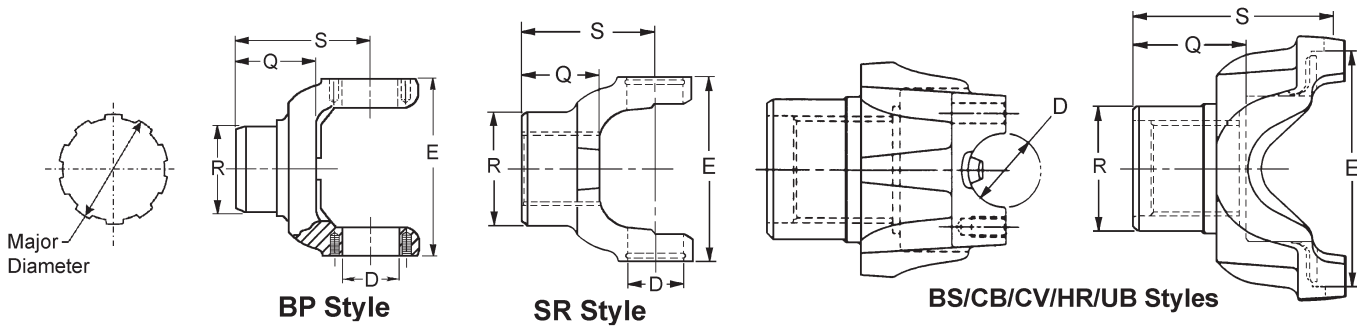

Major Diameter	R	Q	S	C'Bore Depth	Style	End Yoke Assy. (includes slinger/plug) Order When Listed	Slinger/Plug Part Number	Spicer Part Number
	Ground Hub Dia.	Length Thru Hole	Centerline to End					

1710 SERIES (Continued) E-6.094 (6.190 FOR HR STYLE) D-1.938 USE KIT 5-280X, & 5-675X

FOR HR STYLE USE STRAP KIT 6.5-70-18X

2.005-15 Involute Spline

2.005	2.875	2.500	5.375	.250	BP			6-4-3001
-------	-------	-------	-------	------	----	--	--	----------

2.024-39 Spline

2.024	2.750	2.000	5.000	.120	BP	6-4-8331X	232042-2	6-4-5851
2.024	2.750	2.000	5.000	.120	HR	6-4-8331-1X	232042-2	6-4-5851-1
2.024	2.750	2.000	5.875	.120	BP	6-4-8361X	232042-2	6-4-6571■ High angle yoke
2.024	2.750	2.000	5.875	.120	HR	6-4-8361-1X	232042-2	6-4-6571-1• High angle yoke
2.024	2.750	2.438	4.812	.090	BP	6-4-6941X	231599	6-4-5541•
2.024	2.750	2.438	5.250	.090	BP	6-4-6951X	231599	6-4-5521
2.024	2.750	2.438	5.250	.090	HR	6-4-6951-1X	231599	6-4-5521-1
2.024	2.750	2.438	6.500	.090	BP	6-4-6871X	231599	6-4-5501
2.024	2.750	2.438	6.500	.090	HR	6-4-6871-1X	231599	6-4-5501-1• High angle yoke
2.024	3.000	2.312	5.156	.090	HR	6-4-7631-1X	231102	6-4-7621-1
2.024	3.000	2.312	5.156	.090	HR	6-4-8601-1X■	232182	6-4-7621-1
2.024	3.000	2.312	5.156	.090	HR	6-4-7641-1X	231359	6-4-7621-1
2.024	3.000	2.312	6.250	.090	BP	6-4-8571X	232182	6-4-6371 High angle yoke
2.024	3.000	2.312	6.250	.090	BP	6-4-6381X	231102	6-4-6371 High angle yoke
2.024	3.000	2.312	6.250	.090	BP	6-4-6391X	231359	6-4-6371 High angle yoke
2.024	3.000	2.312	6.250	.090	HR	6-4-8571-1X	232182	6-4-6371-1 High angle yoke
2.024	3.000	2.312	6.250	.090	HR	6-4-6391-1X	231359	6-4-6371-1 High angle yoke
2.024	3.000	2.327	5.156	.090	BP	6-4-6421X	231359	6-4-6401
2.024	3.000	2.327	5.156	.090	BP	6-4-6411X	231102	6-4-6401
2.024	3.000	2.327	5.156	.090	HR	6-4-6421-1X	231866	6-4-6401-1■
2.024	3.000	2.438	5.188	.120	BP	6-4-5101X	231102	6-4-4901■
2.024	3.000	2.438	6.281	.120	BP			6-4-4971 High angle yoke
2.024	3.000	2.500	5.438	.280	HR			6-4-9411-1

2.024-39 Involute Spline

2.024	2.625	2.250	5.250	.250	BP	6-4-6001X	230909	6-4-5991 Chamfered counterbore
2.024	2.625	2.250	5.250	.250	BP	6-4-8531X	232167	6-4-7991
2.024	2.625	2.250	5.250	.250	HR	6-4-8231-1X	232039	6-4-7991-1•

• Part is discontinued ■ Part is available until supply is exhausted ▲ Not sold separately



END YOKES with SPLINED HOLES



Major Diameter	R	Q	S	C'Bore Depth	Style	End Yoke Assy. (includes slinger/plug) Order When Listed	Slinger/Plug Part Number	Spicer Part Number
	Ground Hub Dia.	Length Thru Hole	Centerline to End					
1710 SERIES (Continued) E-6.094 (6.190 FOR HR STYLE) D-1.938 USE KIT 5-280X, & 5-675X								
FOR HR STYLE USE STRAP KIT 6.5-70-18X								
2.024-39 Involute Spline (Continued)								
2.024	2.625	2.250	5.250	.250	HR	6-4-8531-1X	232167	6-4-7991-1•
2.024	2.625	2.250	6.125	.250	BP	6-4-6021X	230909	6-4-6011 <i>High angle yoke; Chamfered counterbore</i>
2.024	2.625	2.250	6.125	.250	HR	6-4-6021-1X	230909	6-4-6011-1 ▲ <i>High angle yoke; Chamfered counterbore</i>
2.024	2.625	2.250	6.125	.250	BP	6-4-8541X	232167	6-4-7981 <i>High angle yoke</i>
2.024	2.625	2.250	6.125	.250	HR	6-4-8541-1X	232167	6-4-7981-1• <i>High angle yoke</i>
2.024	2.625	2.500	5.250	.250	BP	6-4-9041X	232514	6-4-8441
2.024	2.625	2.500	5.250	.250	HR	6-4-9041-1X	232514	6-4-8441-1
2.024	2.625	2.500	6.125	.250	BP	6-4-9001X	232514	6-4-8431
2.024	2.625	2.500	6.125	.250	HR	6-4-9001-1X	232514	6-4-8431-1
2.024	3.000	2.250	4.656	.280	HR	6-4-9441-1X•	232199	6-4-9421-1•
2.024	3.000	2.250	4.656	.280	HR	6-4-9431-1X	232200	6-4-9421-1•
2.024	3.000	2.250	6.000	.280	HR	6-4-9301-1X	232200	6-4-9291-1 ▲ <i>High angle yoke</i>
2.024	3.000	2.281	5.250	.250	BP	6-4-9031X	232511	6-4-8421
2.024	3.000	2.281	5.250	.250	HR	6-4-9031-1X	232511	6-4-8421-1
2.024	3.000	2.281	6.125	.250	BP	6-4-8991X	232511	6-4-8411 <i>High angle yoke</i>
2.024	3.000	2.281	6.125	.250	HR	6-4-8991-1X	232511	6-4-8411-1
2.024	3.000	2.500	6.120	.280	HR			6-4-9281-1
2.032-10 Spline								
2.032	2.750	2.000	5.000	.120	BP			6-4-3791
2.032	2.750	2.391	5.375	.500	BP			6-4-2431
2.114-32 Involute Spline								
2.114	3.000	2.250	4.562	.424	BP	6-4-7221X	231750	6-4-5811■
2.114	3.000	2.250	4.562	.424	HR	6-4-8681-1X	232200	6-4-8671-1
2.114	3.000	2.250	6.062	.424	HR	6-4-8761-1X	232200	6-4-8751-1• <i>High angle yoke</i>
2.114	3.000	2.250	6.250	.424	BP	6-4-7171X	231750	6-4-5791 <i>High angle yoke</i>
2.126-33 Involute Spline								
2.126	3.000	2.500	4.562	—	BP			6-4-5471
2.143-41 Involute Spline								
2.143	2.938	2.500	5.190	—	BP	6-4-9171X	232604	6-4-7311•
2.143	2.938	2.500	5.190	—	HR	6-4-7321-1X	231028	6-4-7311-1
2.143	2.938	2.500	5.190	—	HR	6-4-9171-1X	232604	6-4-7311-1
2.143	2.938	2.500	6.125	—	BP	6-4-9181X	232604	6-4-7551 <i>High angle yoke</i>
2.143	2.938	2.500	6.125	—	BP	6-4-7561X	231028	6-4-7551 <i>High angle yoke</i>
2.143	2.938	2.500	6.125	—	HR	6-4-9181-1X	232604	6-4-7551-1 ▲ <i>High angle yoke</i>
2.143	2.938	2.500	6.125	—	HR	6-4-7561-1X	231028	6-4-7551-1 ▲ <i>High angle yoke</i>
2.143	2.938	3.000	6.620	.380	BP	5008446	232168	6-4-10301 ▲ <i>131449K = 5008446 yoke assy & nut# 128049; Spicer axles only; High angle yoke</i>
2.143	2.938	3.000	6.625	.380	BP	6-4-7651X	231028	6-4-7541 <i>High angle yoke</i>
2.143	2.938	3.000	6.625	.380	BP	6-4-9191X	232609	6-4-7541 <i>High angle yoke</i>

• Part is discontinued ■ Part is available until supply is exhausted ▲ Not sold separately



Important: See Safety Information in General Information Section (J300P-GI)

END YOKES with SPLINED HOLES

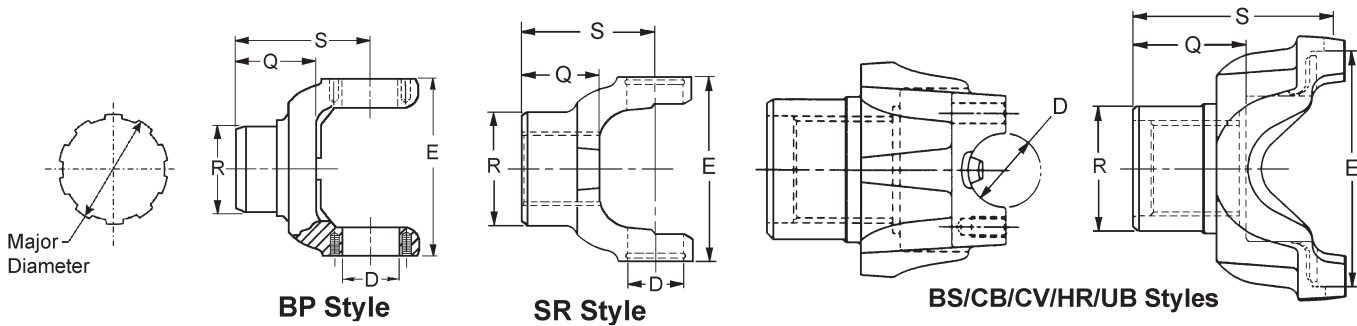

Major Diameter	R	Q	S	C'Bore Depth	Style	End Yoke Assy. (includes slinger/plug) Order When Listed	Slinger/Plug Part Number	Spicer Part Number
	Ground Hub Dia.	Length Thru Hole	Centerline to End					

1710 SERIES (Continued) E-6.094 (6.190 FOR HR STYLE) D-1.938 USE KIT 5-280X, & 5-675X

FOR HR STYLE USE STRAP KIT 6.5-70-18X

2.143-41 Involute Spline (Continued)

2.143	2.938	3.000	6.625	.380	HR	6-4-7651-1X	231028	6-4-7541-1 <i>High angle yoke</i>
2.143	2.938	3.000	6.625	.380	HR	6-4-9191-1X	232609	6-4-7541-1 <i>High angle yoke</i>
2.143	3.000	2.166	5.380	.310	HR	5002877	5002871	5002876 [▲] <i>High angle yoke</i>

2.149-16 Spline

2.149	2.938	2.500	5.188	—	BP	6-4-5061X	231022	6-4-4961•
2.149	2.938	3.000	5.500	.380	BP	6-4-4171X	231028	6-4-2181■
2.149	2.938	3.000	5.500	.380	HR	6-4-4171-1X	231028	6-4-2181-1•
2.149	2.938	3.000	6.625	.380	BP	6-4-5481X	231028	6-4-4591 <i>High angle yoke</i>
2.149	2.938	3.000	6.625	.380	BP	6-4-9841X	232367	6-4-4591 <i>High angle yoke</i>
2.149	2.938	3.000	6.625	.380	HR	6-4-9841-1X•	232367	6-4-4591-1• <i>High angle yoke</i>
2.149	3.000	2.500	4.940	.380	BP			6-4-3491

2.170-34 Involute Spline

2.170	3.543	1.889	4.441	—	HR			5007193 [▲] <i>OEM only</i>
-------	-------	-------	-------	---	----	--	--	---

2.178-43 Involute Spline

2.178	3.539	2.047	4.875	.157	HR			6-4-8561-1
2.178	3.539	2.047	4.875	.157	SR			6-4-9221
2.178	3.539	2.047	4.875	.157	HR			6-4-9221-1

2.225-6 Spline

2.225	2.875	3.250	5.312	—	BP	6-4-2601X•	98-1361	6-4-2331•
2.225	3.000	3.250	5.312	—	BP	6-4-3041X	829-W	6-4-3031
2.225	3.000	3.250	5.312	—	BP	6-4-3461X	330499	6-4-3031
2.225	3.000	3.250	5.438	—	HR	6-4-3041-1X	829-W	6-4-3031-1•

2.250-10 Spline

2.250	3.000	2.875	5.250	—	BP			6-4-2511
2.250	3.000	3.000	5.250	—	BP			6-4-3871
2.250	3.000	3.000	6.062	.250	BP	6-4-4411X	230921	6-4-1991
2.250	3.000	3.000	6.062	.250	HR	6-4-4411-1X•	230921	6-4-1991-1•
2.250	3.000	3.000	7.188	.250	BP	6-4-6891X	230921	6-4-4121• <i>High angle yoke</i>
2.250	3.125	2.250	5.250	—	BP			6-4-2441
2.250	3.250	2.250	5.250	—	BP			6-4-1971
2.250	3.250	3.000	5.250	.250	BP	6-4-4681X	230746	6-4-2501•

• Part is discontinued

■ Part is available until supply is exhausted

▲ Not sold separately



Major Diameter	R	Q	S	C'Bore Depth	Style	End Yoke Assy. (includes slinger/plug) Order When Listed	Slinger/Plug Part Number	Spicer Part Number
	Ground Hub Dia.	Length Thru Hole	Centerline to End					
1710 SERIES (Continued) E-6.094 (6.190 FOR HR STYLE) D-1.938 USE KIT 5-280X, & 5-675X								
FOR HR STYLE USE STRAP KIT 6.5-70-18X								
2.250-10 Spline (Continued)								
2.250	3.500	3.000	5.250	—	BP	6-4-6771X	230674	6-4-2141
2.250	3.500	3.000	5.250	—	HR	6-4-6901-1X	231616	6-4-6861-1•
2.250	3.750	3.000	5.250	—	HR	6-4-7381-1X	231616	6-4-7371-1▲
2.260-6 Spline								
2.260	3.250	2.250	5.300	—	HR	6-4-8291-1X	232042-6	6-4-3501-1▲
2.274-44 Involute Spline								
2.274	2.938	2.359	5.031	—	BP	6-4-7971X	231022	6-4-7961•
2.274	2.938	2.359	5.031	—	BP	6-4-9161X•	232604	6-4-7961•
2.274	2.938	2.359	5.031	—	HR	6-4-7971-1X	231022	6-4-7961-1
2.274	2.938	2.359	5.031	—	HR	6-4-9161-1X	232604	6-4-7961-1
2.274	2.938	2.500	5.188	—	BP	6-4-6041X	231022	6-4-8461
2.274	2.938	2.500	5.188	—	BP	6-4-8551X	232168	6-4-8461
2.274	2.938	2.500	5.188	—	HR	6-4-8551-1X	232168	6-4-8461-1
2.274	2.938	2.500	5.188	—	HR	6-4-6041-1X	231022	6-4-8461-1
2.274	3.000	2.500	5.190	.236	BP	6-4-8981X•	232511	6-4-8451
2.274	3.000	2.500	5.190	.236	HR	6-4-8981-1X	232511	6-4-8451-1
2.343-45 Involute Spline								
2.343	3.750	3.000	5.250	—	BP	6-4-7271X•	231616	6-4-7251▲
2.343	3.750	3.000	5.250	—	HR	6-4-7271-1X	231616	6-4-7251-1•
2.350-16 Spline								
2.350	3.312	2.750	4.938	—	BP	6-4-5071X	230746	6-4-4601 <i>Coupling shaft yoke</i>
2.350	3.750	2.750	5.188	—	BP			6-4-5341 <i>Hub machined for speedometer gear</i>
2.351-16 Spline								
2.351	3.750	2.750	5.188	—	BP			6-4-4531 <i>Hub machined for speedometer gear</i>
2.360-18 Involute Spline								
2.360	3.500	3.375	6.094	—	BP			6-4-5271•
2.364-18 Involute Spline								
2.364	3.000	2.750	5.281	.440	BP			6-4-5831
2.364	3.500	3.375	5.750	—	BP			6-4-4561
2.364	3.500	3.375	5.750	—	HR			6-4-4561-1
2.364	3.500	3.375	6.062	—	BP			6-4-6671•
2.364	3.750	2.344	5.094	—	BP			6-4-6971 <i>Hub machined for speedometer gear</i>
2.364	3.750	2.344	5.094	—	BP			6-4-6971-1• <i>Hub machined for speedometer gear</i>
2.364-23 Involute Spline								
2.364	3.378	1.785	5.312	—	HR			6-4-9521-1
2.364-36 Involute Spline								
2.364	3.000	2.688	5.438	—	BP	6-4-7191X	231750	6-4-5711■
2.364	3.000	2.688	5.438	—	BP	6-4-7211X	231755	6-4-7201•
2.364	3.000	2.688	5.438	—	HR	6-4-8701-1X	232200	6-4-8691-1
2.364	3.000	2.688	5.438	—	HR	6-4-8721-1X	232199	6-4-8711-1▲
2.364	3.000	2.688	6.500	—	BP	6-4-7241X	231750	6-4-5801 <i>High angle yoke</i>
2.364	3.000	2.703	6.500	—	HR	6-4-8781-1X	232200	6-4-8771-1▲ <i>High angle yoke</i>
2.364	3.500	2.500	5.234	.306	HR	6-4-8801-1X	232201	6-4-8791-1•

• Part is discontinued ■ Part is available until supply is exhausted ▲ Not sold separately



Important: See Safety Information in General Information Section (J300P-GI)

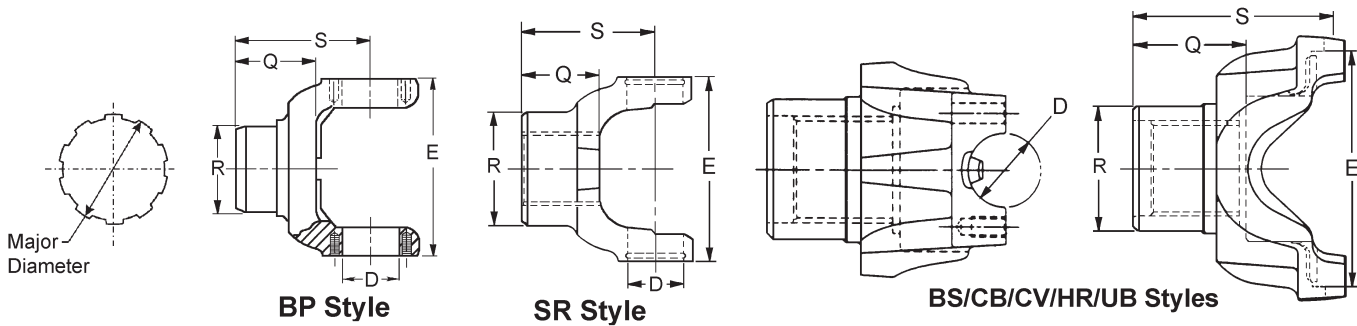

Major Diameter	R	Q	S	C'Bore Depth	Style	End Yoke Assy. (includes slinger/plug) Order When Listed	Slinger/Plug Part Number	Spicer Part Number
	Ground Hub Dia.	Length Thru Hole	Centerline to End					

1710 SERIES (Continued) E-6.094 (6.190 FOR HR STYLE) D-1.938 USE KIT 5-280X, & 5-675X

FOR HR STYLE USE STRAP KIT 6.5-70-18X

2.372-46 Involute Spline

2.372	3.000	3.484	5.734	.490	HR	6-4-7731-1X	231305	6-4-6991-1•
2.372	3.000	3.500	5.750	—	HR	6-4-9321-1XM•	232646	6-4-9311-1M•
								<i>Metric yoke; Part is proprietary to OEM</i>
2.372	3.000	3.875	6.344	—	HR	6-4-9791-1X	232638	6-4-9781-1▲
2.372	3.000	4.000	6.344	—	HR	6-4-6241-1X•	500166-46	6-4-6211-1▲
2.372	3.250	3.220	6.625	.550	HR			6-4-9971-1M
								<i>Metric flanged yoke</i>
2.372	3.125	3.385	6.800	.500	HR			6-4-6231-1
								<i>Flanged end yoke.</i>

2.373-36 Involute Spline

2.373	3.000	1.844	4.250	.300	BP			6-4-5741•
2.373	3.000	2.094	4.250	.310	HR			6-4-10011-1
2.373	3.000	2.094	4.250	.310	HR			6-4-8831-1•
2.373	3.375	2.500	5.094	—	HR			6-4-7081-1•

2.374-46 Spline

2.374	3.250	2.625	5.688	—	BP	6-4-5461X	231179	6-4-5451■
2.374	3.250	2.625	5.688	—	HR	6-4-5461-1X	231179	6-4-5451-1•
2.374	3.250	2.875	5.938	.140	BP	6-4-5961X	231179	6-4-5931•
2.374	3.250	2.875	5.938	.140	BP	6-4-6961X	231615	6-4-5931•
2.374	3.250	2.875	5.938	.140	HR	6-4-6961-1X	231615	6-4-5931-1▲
2.374	3.250	2.875	5.938	.140	HR	6-4-5961-1X■	231179	6-4-5931-1▲
2.374	3.250	2.891	6.938	.140	BP	6-4-7851X	231615	6-4-7831▲
								<i>High angle yoke</i>
2.374	3.250	2.891	6.938	.140	HR	6-4-7851-1X	231615	6-4-7831-1▲
								<i>High angle yoke</i>
2.374	3.500	2.406	5.156	—	BP	6-4-8341X	232042-10	6-4-5841■
2.374	3.500	2.406	5.156	—	HR	6-4-8341-1X	232042-10	6-4-5841-1•
2.374	3.752	2.422	4.938	—	BP	6-4-7881X	231527	6-4-6601
								<i>Hub machined for speedometer gear; Assy inc. mech. speedo gear</i>
2.374	3.752	2.422	4.938	—	HR	6-4-7881-1X	231527	6-4-6601-1
								<i>Hub machined for speedometer gear; Assy inc. mech. speedo gear</i>
2.374	3.752	2.422	4.938	—	HR	6-4-7891-1X	231528	6-4-6601-1
								<i>Hub machined for speedometer gear; Assy inc. elec. speedo gear</i>

2.375-16 Spline

2.375	3.125	2.812	5.312	.690	BP			6-4-3081•
-------	-------	-------	-------	------	----	--	--	-----------

2.390-46 Spline

2.390	3.250	2.312	5.125	.140	HR	6-4-9531-1X	232746	6-4-9911-1▲
2.390	3.250	2.328	5.391	.140	BP	6-4-7181X	231803	6-4-7161▲

• Part is discontinued ■ Part is available until supply is exhausted ▲ Not sold separately



END YOKES with SPLINED HOLES



Major Diameter	R	Q	S	C'Bore Depth	Style	End Yoke Assy. (includes slinger/plug) Order When Listed	Slinger/Plug Part Number	Spicer Part Number
	Ground Hub Dia.	Length Thru Hole	Centerline to End					
1710 SERIES (Continued) E-6.094 (6.190 FOR HR STYLE) D-1.938 USE KIT 5-280X, & 5-675X								
FOR HR STYLE USE STRAP KIT 6.5-70-18X								
2.390-46 Spline (Continued)								
2.390	3.250	2.328	5.391	.140	HR	6-4-7181-1X	231803	6-4-7161-1
2.390	3.250	2.328	5.391	.140	HR	5003553	5003552	6-4-7161-1
2.390	3.250	2.344	6.500	.140	BP	6-4-7771X	231803	6-4-7761• <i>High angle yoke</i>
2.390	3.250	2.344	6.500	.140	HR	6-4-7771-1X	231803	6-4-7761-1▲ <i>High angle yoke</i>
2.390-46 Involute Spline								
2.390	2.875	2.750	4.938	.500	HR			6-4-7481-1 <i>Coupling shaft yoke</i>
2.390	3.250	2.875	5.938	.140	HR			6-4-9131-1
2.390	3.375	3.188	6.000	.580	BP	6-4-7531X	231013	6-4-7511
2.390	3.375	3.188	6.000	.580	HR	6-4-7531-1X	231013	6-4-7511-1•
2.390	3.375	3.188	6.000	.580	HR	6-4-9201-1X	232610	6-4-7511-1•
2.390	3.500	3.375	5.750	—	BP			6-4-4771
2.390	3.500	3.375	5.750	—	HR			6-4-4771-1
2.422-18 Involute Spline								
2.422	3.375	3.000	5.250	—	BP			6-4-3161
2.422	3.375	3.000	5.812	.380	BP	6-4-4751X	231013	6-4-4581
2.422	3.375	3.000	5.812	.380	HR	6-4-4751-1X	231013	6-4-4581-1•
2.423-18 Involute Spline								
2.423	3.146	2.047	5.125	—	HR			6-4-7491-1•
2.450-47 Involute Spline								
2.450	3.900	2.428	5.190	.750	BP			6-4-8471•
2.500	3.250	3.000	4.875	—	BP	6-4-6761X	231179	6-4-2251
2.500	3.250	3.000	5.000	—	HR	6-4-6761-1X	231179	6-4-2251-1▲
2.500	3.250	3.000	5.750	—	BP	6-4-9151X•	231179	6-4-9141▲
2.500	3.500	2.406	5.156	—	BP	6-4-8321X•	232042-10	6-4-4421
2.500	3.500	2.406	5.156	—	HR	6-4-8321-1X	232042-10	6-4-4421-1■
2.500	3.500	2.406	5.156	—	HR	6-4-8351-1X	232042-11	6-4-4421-1■
2.500	3.500	3.000	5.750	—	BP			6-4-4781
2.500	3.750	3.000	5.625	—	BP	6-4-6921X	231616	6-4-6611 <i>Hub machined for speedometer gear</i>
2.500	3.750	3.000	5.625	—	HR	6-4-6921-1X	231616	6-4-6611-1 <i>Hub machined for speedometer gear</i>
2.500-24 Involute Spline								
2.500	3.000	2.422	4.672	—	HR			6-4-8841-1•
2.544-49 Involute Spline								
2.544	3.755	3.000	5.625	—	BP	6-4-7041X	231616	6-4-7051 <i>Hub machined for speedometer gear</i>
2.544	3.755	3.000	5.625	—	HR	6-4-7041-1X	231616	6-4-7051-1■ <i>Hub machined for speedometer gear</i>
2.544	3.819	2.125	5.570	.120	BP	5008452	5008437	6-4-10291▲ <i>131442K = 5008452 yoke assy & nut# 131095; Spicer axles only</i>
2.544	3.819	2.125	5.570	.120	HR	5008453	5008437	6-4-10291-1▲ <i>131437K = 5008453 yoke assy & nut# 131095; Spicer axles only</i>
2.544	3.819	2.125	6.260	.120	BP	5008449	5008437	6-4-10311▲ <i>131439K = 5008449 yoke assy & nut# 131095; Spicer axles only</i>
2.544	3.819	2.125	6.260	.120	HR	5008450	5008437	6-4-10311-1▲ <i>131438K = 5008450 yoke assy & nut# 131095; Spicer axles only</i>
2.544	3.819	2.677	6.050	.240	BP	5008438	5008437	5005579▲ <i>131530K = 5008438 yoke assy & nut# 131095; Spicer axles only</i>
2.544	3.819	2.677	6.050	.240	HR	5008439	5008437	5005580• <i>131519K = 5008439 yoke assy & nut# 131095; Spicer axles only</i>

• Part is discontinued ■ Part is available until supply is exhausted ▲ Not sold separately



Important: See Safety Information in General Information Section (J300P-GI)

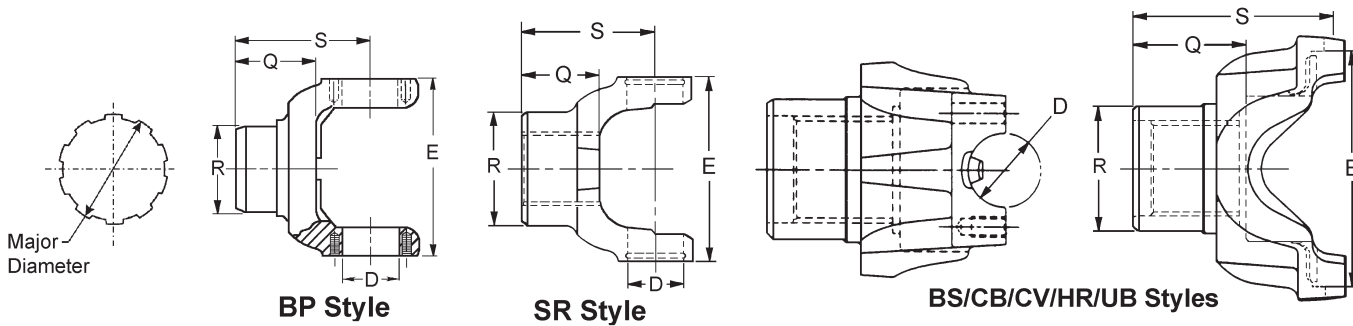

Major Diameter	R	Q	S	C'Bore Depth	Style	End Yoke Assy. (includes slinger/plug) Order When Listed	Slinger/Plug Part Number	Spicer Part Number
	Ground Hub Dia.	Length Thru Hole	Centerline to End					
1710 SERIES (Continued) E-6.094 (6.190 FOR HR STYLE) D-1.938 USE KIT 5-280X, & 5-675X								
FOR HR STYLE USE STRAP KIT 6.5-70-18X								
2.544-49 Involute Spline (Continued)								
2.544	4.000	2.750	5.188	.180	BP			6-4-7691• <i>Hub machined for speedometer gear</i>
2.544	4.000	2.750	5.188	.180	HR			6-4-7691-1 <i>Hub machined for speedometer gear</i>
2.588-40 Involute Spline								
2.588	4.000	3.510	6.340	—	HR	6-4-9751-1XM•	232760	6-4-9741-1M▲
2.588	4.000	3.640	6.340	—	HR	6-4-9571-1XM•	232759	6-4-9561-1M▲
2.631-25 Involute Spline								
2.631	3.625	2.562	5.250	1.000	BP			6-4-4921
2.631	3.625	3.000	5.250	—	BP			6-4-3021
2.635-20 Involute Spline								
2.635	3.750	2.750	5.188	—	BP	6-4-7071X	231745	6-4-5351■ <i>Hub Dia. 3.000 if used on Spicer 1241 Aux. Trans.; Hub machined for speedometer gear</i>
2.635	3.750	2.750	5.188	—	HR	6-4-7071-1X	231745	6-4-5351-1■ <i>Hub Dia. 3.000 if used on Spicer 1241 Aux. Trans.; Hub machined for speedometer gear</i>
2.750-10 Spline								
2.750	3.500	3.000	5.750	—	BP	6-4-5251X	230674	6-4-4551
2.750	3.500	3.000	5.750	—	HR			6-4-4551-1
2.750	3.750	3.000	5.750	—	BP	6-4-6841X	230902	6-4-6631•
2.750	3.750	3.000	5.750	—	HR	6-4-6841-1X	230902	6-4-6631-1▲
2.750	3.750	3.000	5.750	—	BP	6-4-6931X	231616	6-4-6821▲
2.750	3.750	3.000	5.750	—	HR	6-4-6931-1X	231616	6-4-6821-1
2.750	3.812	3.000	5.750	—	HR			6-4-7661-1• <i>Hub diameter not ground.</i>
2.750	4.000	2.938	5.312	—	BP			6-4-4651 <i>Hub machined for speedometer gear</i>
2.750	4.000	2.938	5.312	—	HR			6-4-4651-1 <i>Hub machined for speedometer gear</i>
2.781-21 Involute Spline								
2.781	3.500	3.000	5.812	—	BP			6-4-3671
2.784-55 Involute Spline								
2.784	4.725	2.047	5.000	—	BP			6-4-8851 <i>Metric spline-.120"</i>
2.784	4.725	2.047	5.000	—	HR			6-4-8851-1 <i>Metric spline-.120"</i>
2.794-54 Involute Spline								
2.794	—	2.750	5.625	—	BP			6-4-9231
2.794	—	2.750	5.625	—	HR			6-4-9231-1
2.922-22 Involute Spline								
2.922	3.500	2.625	5.250	—	BP			6-4-5201
2.922	3.750	2.641	5.000	—	HR			6-4-8821-1•

• Part is discontinued

■ Part is available until supply is exhausted

▲ Not sold separately



END YOKES with SPLINED HOLES



Major Diameter	R	Q	S	C'Bore Depth	Style	End Yoke Assy. (includes slinger/plug) Order When Listed	Slinger/Plug Part Number	Spicer Part Number
	Ground Hub Dia.	Length Thru Hole	Centerline to End					
1710 SERIES (Continued) E-6.094 (6.190 FOR HR STYLE) D-1.938 USE KIT 5-280X, & 5-675X								
FOR HR STYLE USE STRAP KIT 6.5-70-18X								
3.003-23 Involute Spline								
3.003	4.000	3.000	4.844	—	BP	6-4-9701X	232193	6-4-9691 ▲
3.003	4.000	3.031	4.844	—	BP			6-4-3141
1760 SERIES E-7.000 (7.094 FOR HR STYLE) D-1.938 USE KIT 5-407X, 5-677X								
FOR HR STYLE USE STRAP KIT 6.5-70-18X								
1.939-30 Involute Spline								
1.939	3.000	2.250	5.250	—	BP			6.3-4-431
1.964-10 Spline								
1.964	2.625	2.250	5.625	.250	BP	6.3-4-221X	230998	6.3-4-111 <i>Chamfered counterbore</i>
1.998-38 Involute Spline								
1.998	3.000	2.125	4.844	—	HR	6.3-4-1501-1X•	232200	6.3-4-1491-1 ▲
2.000-10 Spline								
2.000	2.938	2.562	5.375	—	BP	6.3-4-181X	98-1361	6.3-4-71•
2.024-39 Spline								
2.024	3.000	2.312	5.188	.125	BP	6.3-4-541X	231047	6.3-4-531
2.024	3.000	2.312	5.188	.125	BP	6.3-4-1141-1X•	231866	6.3-4-531-1
2.024	3.000	2.312	5.188	.125	HR	6.3-4-1341-1X•	232028	6.3-4-531-1
2.024	3.000	2.312	5.188	.125	HR	6.3-4-541-1X	231047	6.3-4-531-1
2.024	3.000	2.438	5.188	.120	BP	6.3-4-191X•	231047	6.3-4-81•
2.024-39 Involute Spline								
2.024	3.000	2.250	5.625	.280	HR	6.3-4-1711-1X	232199	6.3-4-1701-1•
2.032-10 Spline								
2.032	2.750	2.000	5.000	—	BP	6.3-4-1261X	232042-2	6.3-4-421•
2.114-32 Involute Spline								
2.114	3.000	2.250	5.000	.424	HR	6.3-4-1521-1X	232200	6.3-4-1511-1
2.143-41 Involute Spline								
2.143	2.938	2.500	5.250	—	BP	6.3-4-1071X	231028	6.3-4-1061•
2.143	2.938	2.500	5.250	—	HR	6.3-4-1631-1X•	232604	6.3-4-1061-1■
2.143	2.938	2.500	5.250	—	HR	6.3-4-1071-1X•	231028	6.3-4-1061-1■
2.143	2.938	3.000	5.812	—	BP	6.3-4-1641X•	232609	6.3-4-1171•
2.149-16 Spline								
2.149	2.938	2.500	5.250	—	BP	6.3-4-231X	231022	6.3-4-121•
2.149	2.938	3.000	5.812	.380	BP	6.3-4-251X■	231028	6.3-4-141•
2.149	2.938	3.000	5.812	.380	HR	6.3-4-251-1X•	231028	6.3-4-141-1▲
2.170-34 Involute Spline								
2.170	3.543	1.889	4.598	—	HR			5007597 ▲ <i>OEM only</i>
2.178-43 Involute Spline								
2.178	3.539	2.050	5.500	.157	HR			6.3-4-1591-1
2.225-6 Spline								
2.225	3.000	3.250	6.000	—	BP	6.3-4-171X	829W	6.3-4-51▲
2.225	3.000	3.250	6.000	—	HR	6.3-4-171-1X	829-W	6.3-4-51-1▲
2.250-10 Spline								
2.250	3.000	3.000	5.844	.250	BP	6.3-4-731X	230921	6.3-4-91■
2.250	3.000	3.000	5.844	.250	HR	6.3-4-731-1X	230921	6.3-4-91-1▲
2.250	3.750	3.000	5.625	—	HR	6.3-4-1101-1X•	231616	6.3-4-1091-1•
2.274-44 Involute Spline								
2.274	2.938	2.328	5.094	—	BP	6.3-4-1621X•	232604	6.3-4-1321▲
2.274	2.938	2.328	5.094	—	BP	6.3-4-1331X	231022	6.3-4-1321▲
2.274	2.938	2.328	5.094	—	HR	6.3-4-1331-1X	231022	6.3-4-1321-1•

• Part is discontinued ■ Part is available until supply is exhausted ▲ Not sold separately



Important: See Safety Information in General Information Section (J300P-GI)

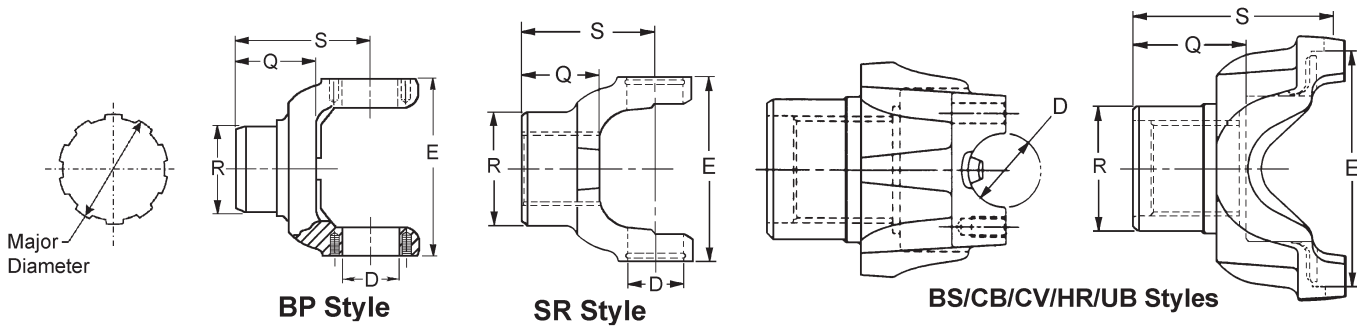

Major Diameter	R	Q	S	C'Bore Depth	Style	End Yoke Assy. (includes slinger/plug) Order When Listed	Slinger/Plug Part Number	Spicer Part Number
	Ground Hub Dia.	Length Thru Hole	Centerline to End					

1760 SERIES (Cont'd) E-7.000 (7.094 FOR HR STYLE) D-1.938 USE KIT 5-407X, 5-677X

FOR HR STYLE USE STRAP KIT 6.5-70-18X

2.274-44 Involute Spline (Continued)

2.274	2.938	2.328	5.094	—	HR	6.3-4-1621-1X	232604	6.3-4-1321-1•
2.274	2.938	2.500	5.250	—	BP	6.3-4-331X	231022	6.3-4-1421
2.274	2.938	2.500	5.250	—	BP	6.3-4-1481X	232168	6.3-4-1421
2.274	2.938	2.500	5.250	—	HR	6.3-4-331-1X	231022	6.3-4-1421-1
2.274	2.938	2.500	5.250	—	HR	6.3-4-1481-1X	232168	6.3-4-1421-1
2.274	3.000	2.500	5.250	.236	BP	6.3-4-5221X	232511	6.3-4-1411
2.274	3.000	2.500	5.250	.236	HR	6.3-4-5221-1X	232511	6.3-4-1411-1•

2.343-45 Involute Spline

2.343	3.750	3.000	5.656	—	HR	6.3-4-901-1X•	231616	6.3-4-841-1•
-------	-------	-------	-------	---	----	---------------	--------	--------------

2.350-16 Spline

2.350	2.875	2.750	5.500	—	BP			6.3-4-161 Coupling shaft yoke
2.350	2.875	2.750	5.500	—	HR			6.3-4-161-1 Coupling shaft yoke

2.364-18 Involute Spline

2.364	3.500	3.375	6.125	—	BP			6.3-4-271
2.364	3.500	3.375	6.125	—	HR			6.3-4-271-1
2.364	3.750	2.328	5.500	—	HR			6.3-4-751-1• <i>Hub machined for speedometer gear</i>

2.364-36 Involute Spline

2.364	3.000	2.688	5.438	—	HR	6.3-4-1541-1X	232200	6.3-4-1531-1▲
2.364	3.000	2.688	5.438	—	HR	6.3-4-1561-1X	232199	6.3-4-1551-1■
2.364	3.000	2.688	5.438	—	BP	6.3-4-1021X	231750	6.3-4-441•
2.364	3.000	2.688	5.438	—	BP	6.3-4-851X	231755	6.3-4-831▲
2.364	3.500	2.485	5.230	.306	HR	6.3-4-1611-1X	232201	6.3-4-1601-1•

2.374-46 Spline

2.374	3.250	2.625	5.438	—	BP	6.3-4-211X	231179	6.3-4-101•
2.374	3.250	2.625	5.438	—	HR	6.3-4-211-1X	231179	6.3-4-101-1•
2.374	3.250	2.875	5.625	.140	BP	6.3-4-861X	231615	6.3-4-291•
2.374	3.250	2.875	5.625	.140	BP	6.3-4-301X	231179	6.3-4-291•
2.374	3.250	2.875	5.625	.140	HR	6.3-4-301-1X	231179	6.3-4-291-1•
2.374	3.250	2.875	5.625	.140	HR	6.3-4-861-1X	231615	6.3-4-291-1•
2.374	3.500	2.406	5.375	—	BP	6.3-4-1391X	232042-10	6.3-4-391
2.374	3.500	2.406	5.375	—	HR	6.3-4-1391-1X	232042-10	6.3-4-391-1•
2.374	3.750	2.422	5.406	—	BP	6.3-4-1281X		6.3-4-641
								<i>Assy includes electronic speedometer #231528</i>
2.374	3.750	2.422	5.406	—	HR	6.3-4-1281-1X		6.3-4-641-1
								<i>Assy includes electronic speedometer #231528</i>

• Part is discontinued

■ Part is available until supply is exhausted

▲ Not sold separately



END YOKES with SPLINED HOLES



Major Diameter	R	Q	S	C'Bore Depth	Style	End Yoke Assy. (includes slinger/plug) Order When Listed	Slinger/Plug Part Number	Spicer Part Number
	Ground Hub Dia.	Length Thru Hole	Centerline to End					
1760 SERIES (Cont'd) E-7.000 (7.094 FOR HR STYLE) D-1.938						USE KIT 5-407X, 5-677X		
FOR HR STYLE USE STRAP KIT 6.5-70-18X								
2.374-46 Spline (Continued)								
2.374	3.750	2.422	5.406	—	HR	6.3-4-1271-1X <i>Assy includes mechanical speedometer drive gear #231527</i>		6.3-4-641-1
2.390-46 Involute Spline								
2.390	2.875	2.750	5.500	—	HR			6.3-4-821-1 <i>Coupling shaft yoke</i>
2.390	3.250	2.328	5.062	.140	BP	6.3-4-1041X	231803	6.3-4-1031•
2.390	3.250	2.328	5.062	.140	HR	6.3-4-1041-1X	231803	6.3-4-1031-1
2.390	3.250	2.328	5.062	.140	HR	5003555	5003552	6.3-4-1031-1
2.390	3.375	3.188	6.000	.580	BP	6.3-4-1161X	231013	6.3-4-1151•
2.390	3.375	3.188	6.000	.580	BP	6.3-4-1651X•	232610	6.3-4-1151•
2.390	3.375	3.188	6.000	.580	HR	6.3-4-1161-1X	231013	6.3-4-1151-1•
2.390	3.375	3.188	6.000	.580	HR	6.3-4-1651-1X	232610	6.3-4-1151-1•
2.390	3.500	3.375	6.000	—	BP			6.3-4-381
2.390	3.500	3.375	6.000	—	HR			6.3-4-381-1
2.422-18 Involute Spline								
2.422	3.375	3.000	6.000	.380	BP	6.3-4-241X	231013	6.3-4-131•
2.422	3.375	3.000	6.000	.380	HR	6.3-4-241-1X•	231013	6.3-4-131-1▲
2.500-10 Spline								
2.500	3.500	2.406	5.406	—	BP	6.3-4-1401X	232042-11	6.3-4-151■
2.500	3.500	2.406	5.406	—	HR	6.3-4-1401-1X	232042-11	6.3-4-151-1•
2.500	3.750	3.000	6.000	—	BP	6.3-4-781X	231616	6.3-4-651 <i>Hub machined for speedometer gear</i>
2.500	3.750	3.000	6.031	—	HR	6.3-4-781-1X	231616	6.3-4-651-1 <i>Hub machined for speedometer gear</i>
2.503-19 Involute Spline								
2.503	3.344	3.000	5.938	—	BP			6.3-4-521
2.544-49 Involute Spline								
2.544	3.750	3.000	6.031	—	BP	6.3-4-771X	231616	6.3-4-811• <i>Hub machined for speedometer gear</i>
2.544	3.750	3.000	6.031	—	HR	6.3-4-771-1X	231616	6.3-4-811-1▲ <i>Hub machined for speedometer gear</i>
2.544	3.818	2.141	5.200	.120	BP	5008454	5008437	6.3-4-1861▲ <i>131441K = 5008454 yoke assy & nut# 131095; Spicer axles only</i>
2.544	3.818	2.141	5.200	.120	HR	5008455	5008437	6.3-4-1861-1▲ <i>131440K = 5008455 yoke assy & nut# 131095; Spicer axles only</i>
2.544	3.819	2.677	5.750	.240	BP	5008440	5008437	5005581▲ <i>131518K = 5008440 yoke assy & nut# 131095; Spicer axles only</i>
2.544	3.819	2.677	6.050	.240	HR	5008441	5008437	5005582▲ <i>131482K = 5008441 yoke assy & nut# 131095; Spicer axles only</i>
2.544	4.000	2.750	5.562	.180	BP			6.3-4-1251•
2.544	4.000	2.750	5.562	.180	HR			6.3-4-1251-1
2.635-20 Involute Spline								
2.635	3.750	2.750	5.562	—	BP	6.3-4-871X	231745	6.3-4-41• <i>Hub machined for speedometer gear</i>
2.635	3.750	2.750	5.562	—	HR	6.3-4-871-1X	231745	6.3-4-41-1■ <i>Hub machined for speedometer gear</i>
2.750-10 Spline								
2.750	3.750	3.000	5.969	—	BP	6.3-4-721X	230902	6.3-4-661▲
2.750	3.750	3.000	5.969	—	HR	6.3-4-721-1X	230902	6.3-4-661-1■
2.750	3.750	3.000	5.969	—	BP	6.3-4-791X	231616	6.3-4-711
2.750	3.750	3.000	5.969	—	HR	6.3-4-791-1X	231616	6.3-4-711-1
2.750	4.000	2.938	6.000	—	BP			6.3-4-61 <i>Hub machined for speedometer gear</i>

• Part is discontinued ■ Part is available until supply is exhausted ▲ Not sold separately



Important: See Safety Information in General Information Section (J300P-GI)

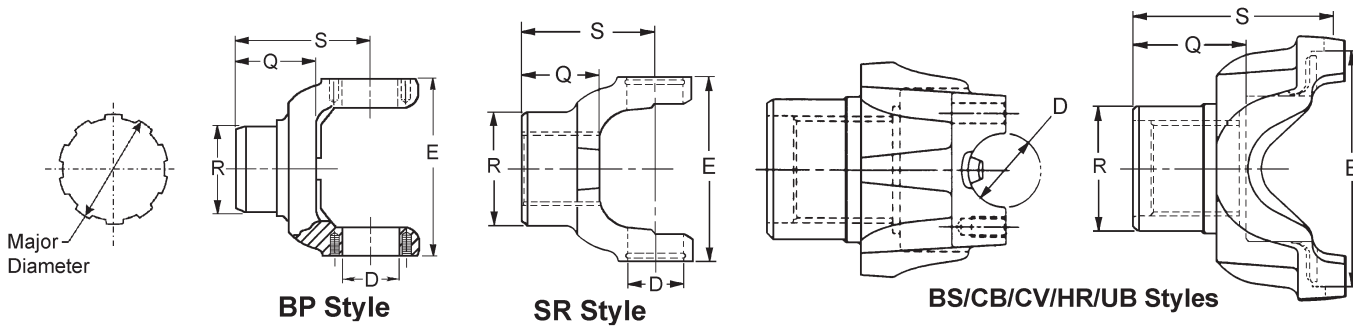

Major Diameter	R	Q	S	C'Bore Depth	Style	End Yoke Assy. (includes slinger/plug) Order When Listed	Slinger/Plug Part Number	Spicer Part Number
	Ground Hub Dia.	Length Thru Hole	Centerline to End					
1760 SERIES (Cont'd) E-7.000 (7.094 FOR HR STYLE) D-1.938						USE KIT 5-407X, 5-677X		

FOR HR STYLE USE STRAP KIT 6.5-70-18X

2.750-10 Spline (Continued)

2.750	4.000	2.938	6.000	—	HR			6.3-4-61-1 <i>Hub machined for speedometer gear</i>
2.794-54 Involute Spline								
2.794	—	2.750	5.625	—	BP			6.3-4-1681 <i>Hub diameter not ground.</i>
2.794	—	2.750	5.625	—	HR			6.3-4-1681-1 <i>Hub diameter not ground.</i>
2.794	3.750	3.000	5.970	—	HR			6.3-4-1051-1•
2.798-21 Involute Spline								
2.798	3.531	2.078	4.844	.080	HR			6.3-4-1191-1
3.045-48 Involute Spline								
3.045	4.250	1.955	4.882	—	HR			5005679▲ <i>OEM only</i>

1800 SERIES E-6.594 D-2.312 USE KIT 5-124X

2.002-15 Involute Spline

2.002	3.250	2.703	4.938	.687	BP			6.5-4-2961
-------	-------	-------	-------	------	----	--	--	------------

1810 SERIES E-7.547 (7.643 FOR HR STYLE) D-1.938 USE KIT 5-281X, 5-676X

FOR HR STYLE USE STRAP KIT 6.5-70-18X

1.939-30 Involute Spline

1.939	3.000	2.250	5.375	—	BP			6.5-4-2051
-------	-------	-------	-------	---	----	--	--	------------

1.964-10 Spline

1.964	2.625	2.250	5.625	.250	BP	6.5-4-2351X	230998	6.5-4-2001 <i>Chamfered counterbore</i>
-------	-------	-------	-------	------	----	-------------	--------	--

2.000-10 Spline

2.000	2.938	2.562	5.375	—	BP	6.5-4-2341X	98-1361	6.5-4-1921•
-------	-------	-------	-------	---	----	-------------	---------	-------------

2.005-15 Involute Spline

2.005	2.875	2.500	5.250	.250	BP			6.5-4-2911
-------	-------	-------	-------	------	----	--	--	------------

2.005	3.250	2.375	5.281	—	BP			6.5-4-2821 <i>Tapered spline.</i>
-------	-------	-------	-------	---	----	--	--	--------------------------------------

2.024-39 Spline

2.024	2.750	2.000	5.188	.125	BP	6.5-4-4281X	232042-2	6.5-4-3261
2.024	2.750	2.000	5.188	.125	HR	6.5-4-4281-1X	232042-2	6.5-4-3261-1
2.024	2.750	2.438	5.531	.090	BP	6.5-4-3571X	231599	6.5-4-2781•
2.024	2.750	2.438	5.625	.090	HR	6.5-4-3571-1X•	231599	6.5-4-2781-1▲
2.024	3.000	2.312	5.190	.120	BP	6.5-4-3381X	231047	6.5-4-3371
2.024	3.000	2.312	5.190	.120	HR	6.5-4-4191-1X•	232028	6.5-4-3371-1
2.024	3.000	2.312	5.190	.120	HR	6.5-4-3381-1X	231047	6.5-4-3371-1
2.024	3.000	2.312	5.750	.120	HR	6.5-4-3881-1X	231047	6.5-4-3861-1▲

• Part is discontinued

■ Part is available until supply is exhausted

▲ Not sold separately



END YOKES with SPLINED HOLES



Major Diameter	R	Q	S	C'Bore Depth	Style	End Yoke Assy. (includes slinger/plug) Order When Listed	Slinger/Plug Part Number	Spicer Part Number	
	Ground Hub Dia.	Length Thru Hole	Centerline to End						
1810 SERIES (Cont'd) E-7.547 (7.643 FOR HR STYLE) D-1.938							USE KIT 5-281X, 5-676X		
FOR HR STYLE USE STRAP KIT 6.5-70-18X									
2.024-39 Spline (Continued)									
2.024	3.000	2.320	5.188	.090	HR	6.5-4-3851-1X	231047	6.5-4-3841-1 ▲	
2.024	3.000	2.438	5.188	.120	BP	6.5-4-2491X	231047	6.5-4-2471•	
2.024-39 Involute Spline									
2.024	3.000	2.250	5.000	.280	HR	6.5-4-4661-1X	232199	6.5-4-4651-1•	
2.031-10 Spline									
2.031	2.750	2.000	5.250	.125	BP	6.5-4-4251X	232042-2	6.5-4-2261■	
2.114-32 Involute Spline									
2.114	3.000	2.250	5.000	.424	HR	6.5-4-4461-1X	232200	6.5-4-4451-1 ▲	
2.143-41 Involute Spline									
2.143	2.938	2.500	5.250	—	BP	6.5-4-4601X■	232604	6.5-4-3681•	
2.143	2.938	2.500	5.250	—	BP	6.5-4-3691X	231028	6.5-4-3681•	
2.143	2.938	2.500	5.250	—	HR	6.5-4-4601-1X•	232604	6.5-4-3681-1 ▲	
2.143	2.938	2.500	5.250	—	HR	6.5-4-3691-1X•	231028	6.5-4-3681-1 ▲	
2.143	2.938	3.000	5.812	.380	BP	6.5-4-4621X•	232609	6.5-4-3931	
2.143	2.938	3.000	5.812	.380	BP			6.5-4-3931	
2.143	2.938	3.000	6.620	.380	HR	5008447	232168	6.4-10301-1 ▲	
<i>131450K = 5008447 yoke assy & nut# 131095; Spicer axles only</i>									
2.149-16 Spline									
2.149	2.938	2.500	5.219	—	BP	6.5-4-2451X	231022	6.5-4-2441■	
2.149	2.938	3.000	5.812	.380	BP	6.5-4-2401X	231028	6.5-4-2291•	
2.149	2.938	3.000	5.812	.380	HR	6.5-4-2401-1X•	231028	6.5-4-2291-1 ▲	
2.225-6 Spline									
2.225	3.000	3.250	6.000	—	BP	6.5-4-2831X	330499	6.5-4-1971	
2.225	3.000	3.250	6.000	—	BP	6.5-4-2271X	829-W	6.5-4-1971	
2.225	3.000	3.250	6.000	—	HR			6.5-4-1971-1	
2.250-10 Spline									
2.250	2.875	3.000	5.875	.312	BP			6.5-4-2131	
2.250	3.000	3.000	5.844	.250	BP	6.5-4-2551X	230921	6.5-4-1911■	
2.250	3.125	2.250	5.375	—	HR	6.5-4-4221-1X•	232042-3	6.5-4-2141-1 ▲	
2.250	3.312	2.250	5.375	—	HR	6.5-4-4241-1X	232042-6	6.5-4-4231-1•	
2.250	3.500	3.000	5.844	—	BP			6.5-4-2021	
2.274-44 Involute Spline									
2.274	2.938	2.344	5.090	—	HR	6.5-4-4591-1X	232604	6.5-4-4081-1	
2.274	2.938	2.344	5.090	—	HR	6.5-4-4091-1X	231022	6.5-4-4081-1	
2.274	2.938	2.500	5.250	—	BP	6.5-4-4351X	232168	6.5-4-4321	
2.274	2.938	2.500	5.250	—	BP	6.5-4-3281X	231022	6.5-4-4321	
2.274	2.938	2.500	5.250	—	HR	6.5-4-4351-1X	232168	6.5-4-4321-1	
2.274	2.938	2.500	5.250	—	HR	6.5-4-3281-1X	231022	6.5-4-4321-1	
2.274	3.000	2.500	5.250	.236	BP	6.5-4-4571X	232511	6.5-4-4311	
2.274	3.000	2.500	5.250	.236	HR	6.5-4-4571-1X	232511	6.5-4-4311-1	
2.350-16 Spline									
2.350	2.875	2.750	5.500	—	BP	6.5-4-2531X	230746	6.5-4-1891 <i>Coupling shaft yoke</i>	
2.350	2.875	2.750	5.500	—	HR			6.5-4-1891-1 <i>Coupling shaft yoke</i>	
2.350	3.750	2.750	5.562	—	BP			6.5-4-3011 <i>Hub machined for speedometer gear</i>	
2.364-18 Involute Spline									
2.364	3.500	3.375	6.125	—	BP			6.5-4-2581	
2.364	3.500	3.375	6.125	—	HR			6.5-4-2581-1	
2.364	3.750	2.344	5.625	—	HR			6.5-4-4211-1 <i>Hub machined for speedometer gear</i>	

• Part is discontinued ■ Part is available until supply is exhausted ▲ Not sold separately



Important: See Safety Information in General Information Section (J300P-GI)

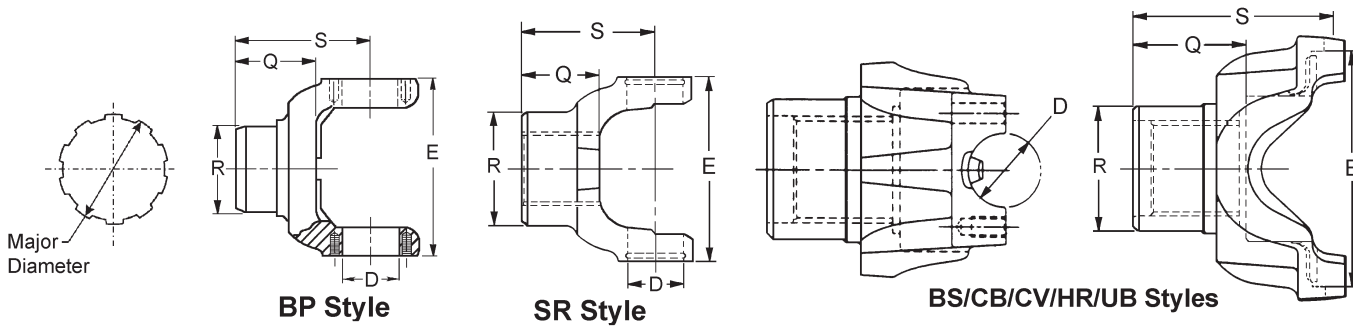

Major Diameter	R	Q	S	C'Bore Depth	Style	End Yoke Assy. (includes slinger/plug) Order When Listed	Slinger/Plug Part Number	Spicer Part Number
	Ground Hub Dia.	Length Thru Hole	Centerline to End					

1810 SERIES (Cont'd) E-7.547 (7.643 FOR HR STYLE) D-1.938 USE KIT 5-281X, 5-676X

FOR HR STYLE USE STRAP KIT 6.5-70-18X

2.364-36 Involute Spline

2.364	3.000	2.688	5.438	—	BP	6.5-4-3651X	231750	6.5-4-3161■
2.364	3.000	2.688	5.438	—	BP	6.5-4-3641X	231755	6.5-4-3631▲
2.364	3.000	2.688	5.438	—	HR	6.5-4-4421-1X	232200	6.5-4-4411-1•
2.364	3.000	2.688	5.438	—	HR	6.5-4-4441-1X	232199	6.5-4-4431-1▲
2.364	3.500	2.500	5.230	.300	HR	6.5-4-4481-1X	232201	6.5-4-4471-1•

2.374-46 Spline

2.374	3.250	2.625	5.438	—	BP	6.5-4-2711X	231179	6.5-4-2701
2.374	3.250	2.625	5.438	—	HR	6.5-4-2711-1X	231179	6.5-4-2701-1•
2.374	3.250	2.875	5.688	.140	BP	6.5-4-3581X	231615	6.5-4-3201•
2.374	3.250	2.875	5.688	.140	BP	6.5-4-3221X	231179	6.5-4-3201•
2.374	3.250	2.875	5.688	.140	HR	6.5-4-3581-1X	231615	6.5-4-3201-1■
2.374	3.250	2.875	5.688	.140	HR	6.5-4-3221-1X	231179	6.5-4-3201-1■
2.374	3.500	2.406	5.406	—	BP	6.5-4-4271X	232042-10	6.5-4-3251
2.374	3.500	2.406	5.406	—	HR	6.5-4-4271-1X	232042-10	6.5-4-3251-1
2.374	3.750	2.406	5.219	—	BP	6.5-4-4001X•		6.5-4-3441
<i>Assy includes electronic speedometer gear #231528</i>								
2.374	3.750	2.406	5.219	—	BP	6.5-4-4011X	231528	6.5-4-3441
<i>Assy includes mechanical speedometer drive gear #231527</i>								
2.374	3.750	2.406	5.219	—	HR	6.5-4-4011-1X		6.5-4-3441-1▲
<i>Assy includes electronic speedometer gear #231528</i>								
2.374	3.750	2.406	5.219	—	HR	6.5-4-4001-1X		6.5-4-3441-1▲
<i>Assy includes mechanical speedometer drive gear #231527</i>								

2.390-46 Involute Spline

2.390	2.875	2.750	5.500	—	HR			6.5-4-3591-1 <i>Coupling shaft yoke</i>
2.390	3.250	2.312	5.156	.140	BP	6.5-4-3731X	231803	6.5-4-3721▲
2.390	3.250	2.312	5.156	.140	HR	5003556	5003552	6.5-4-3721-1
2.390	3.250	2.312	5.156	.140	HR	6.5-4-4511-1X	211831X	6.5-4-3721-1
2.390	3.250	2.312	5.156	.140	HR	6.5-4-3731-1X	231803	6.5-4-3721-1
2.390	3.250	2.312	5.156	.140	HR	6.5-4-4721-1X	232747	6.5-4-3721-1
2.390	3.375	3.188	6.000	.580	BP	6.5-4-4611X	232610	6.5-4-3911
2.390	3.375	3.188	6.000	.580	BP	6.5-4-3921X	231013	6.5-4-3911
2.390	3.375	3.188	6.000	.580	HR	6.5-4-4611-1X	232610	6.5-4-3911-1
2.390	3.375	3.188	6.000	.580	HR	6.5-4-3921-1X	231013	6.5-4-3911-1
2.390	3.500	3.375	6.156	—	BP			6.5-4-2541
2.390	3.500	3.375	6.156	—	HR			6.5-4-2541-1

2.422-18 Involute Spline

2.422	3.375	3.000	5.812	.380	BP	6.5-4-2361X	231013	6.5-4-1991
2.422	3.375	3.000	5.812	.380	HR	6.5-4-2361-1X	231013	6.5-4-1991-1•

• Part is discontinued ■ Part is available until supply is exhausted ▲ Not sold separately



END YOKES with SPLINED HOLES



Major Diameter	R	Q	S	C'Bore Depth	Style	End Yoke Assy. (includes slinger/plug) Order When Listed	Slinger/Plug Part Number	Spicer Part Number	
	Ground Hub Dia.	Length Thru Hole	Centerline to End						
1810 SERIES (Cont'd) E-7.547 (7.643 FOR HR STYLE) D-1.938							USE KIT 5-281X, 5-676X		
FOR HR STYLE USE STRAP KIT 6.5-70-18X									
2.450-47 Involute Spline									
2.450	3.625	2.500	5.312	.750	BP			6.5-4-2921	
2.500-10 Spline									
2.500	3.250	3.000	5.781	—	BP	6.5-4-3711X	231179	6.5-4-2561	
2.500	3.250	3.000	5.781	—	HR	6.5-4-3711-1X	231179	6.5-4-2561-1	
2.500	3.500	2.406	5.406	—	BP	6.5-4-4291X	232042-11	6.5-4-2101▪	
2.500	3.500	2.406	5.406	—	HR	6.5-4-4261-1X	232042-11	6.5-4-2101-1	
2.500	3.500	2.406	5.406	—	HR	6.5-4-4291-1X	232042-11	6.5-4-2101-1	
2.500	3.500	3.000	5.781	—	BP			6.5-4-2151▪	
2.500	3.750	3.000	5.875	—	BP	6.5-4-3551X	231616	6.5-4-3451• <i>Hub machined for speedometer gear</i>	
2.500	3.750	3.000	5.875	—	HR	6.5-4-3551-1X	231616	6.5-4-3451-1 <i>Hub machined for speedometer gear</i>	
2.544-49 Involute Spline									
2.544	3.750	3.000	5.875	—	BP	6.5-4-3621X•	231616	6.5-4-3611▲ <i>Hub machined for speedometer gear</i>	
2.544	3.750	3.000	5.875	—	HR	6.5-4-3621-1X	231616	6.5-4-3611-1•	
2.544	3.818	2.141	5.740	.120	BP	5008456	5008437	6.5-4-5091▲ <i>131444K = 5008456 yoke Assy & nut# 131095; Spicer axles only</i>	
2.544	3.818	2.141	5.740	.120	HR	5008457	5008437	6.5-4-5091-1• <i>131443K = 5008457 yoke Assy & nut# 131095; Spicer axles only</i>	
2.544	3.819	2.677	5.740	—	BP	5008442	5008437	6.5-4-5101▲ <i>131448K = 5008442 yoke Assy & nut# 131095; Spicer axles only</i>	
2.544	3.820	2.692	5.740	.240	HR	5008443	5008437	6.5-4-5101-1• <i>131447K = 5008443 yoke Assy & nut# 131095; Spicer axles only</i>	
2.544	4.000	2.750	5.562	.180	HR			6.5-4-3821-1	
2.560-20 Involute Spline									
2.560	3.500	3.344	6.125	—	BP			6.5-4-3361	
2.560	3.500	3.344	6.125	—	HR			6.5-4-3361-1	
2.631-25 Involute Spline									
2.631	3.625	3.000	5.781	1.000	BP			6.5-4-2181	
2.635-20 Involute Spline									
2.635	3.750	2.750	5.562	—	BP			6.5-4-2011 <i>Hub machined for speedometer gear</i>	
2.635	3.750	2.750	5.562	—	BP	6.5-4-3541X	231745	6.5-4-3021 <i>Hub Dia. 3.000 if used on Spicer 1241 Aux. Trans.; Hub machined for speedometer gear</i>	
2.635	3.750	2.750	5.562	—	HR	6.5-4-3541-1X	231745	6.5-4-3021-1▪ <i>Hub Dia. 3.000 if used on Spicer 1241 Aux. Trans.; Hub machined for speedometer gear</i>	
2.635	3.750	3.312	6.062	.560	BP	6.5-4-2601X•	230888	6.5-4-1941•	
2.635	4.000	3.281	6.062	.560	BP	6.5-4-4551X	230888	6.5-4-4541▲	
2.750-10 Spline									
2.750	3.500	3.000	6.062	—	BP	6.5-4-2931X	230674	6.5-4-1901	
2.750	3.750	3.000	6.062	—	BP	6.5-4-3501X	230902	6.5-4-3461•	
2.750	3.750	3.000	6.062	—	HR	6.5-4-3501-1X	230902	6.5-4-3461-1•	
2.750	3.750	3.000	6.062	.120	BP	6.5-4-3561X	231616	6.5-4-3491▪	
2.750	3.750	3.000	6.062	.120	HR	6.5-4-3561-1X	231616	6.5-4-3491-1	
2.750	3.875	3.000	6.062	—	HR			6.5-4-3801-1 <i>Hub diameter not ground.</i>	
2.750	4.000	2.938	6.000	—	BP			6.5-4-2171 <i>Hub machined for speedometer gear</i>	
2.750	4.000	2.938	6.000	—	HR			6.5-4-2171-1 <i>Hub machined for speedometer gear</i>	

• Part is discontinued ■ Part is available until supply is exhausted ▲ Not sold separately



Important: See Safety Information in General Information Section (J300P-GI)

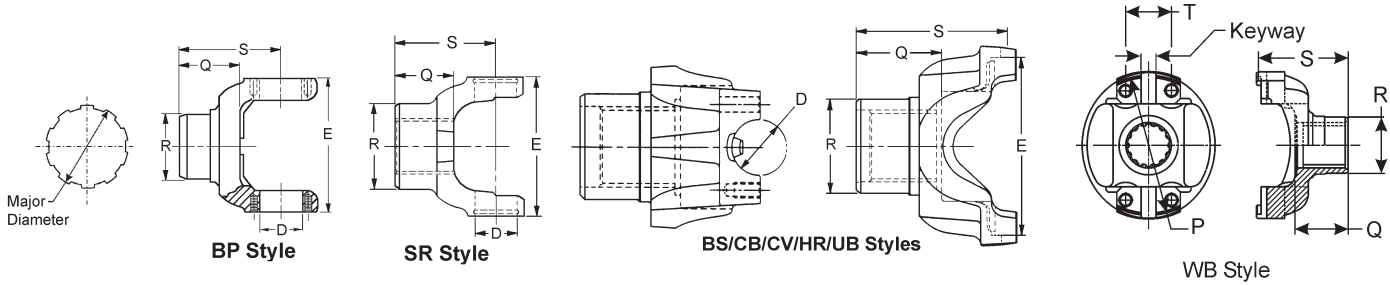

Major Diameter	R	Q	S	C'Bore Depth	Style	End Yoke Assy. (includes slinger/plug) Order When Listed	Slinger/Plug Part Number	Spicer Part Number
	Ground Hub Dia.	Length Thru Hole	Centerline to End					
1810 SERIES (Cont'd) E-7.547 (7.643 FOR HR STYLE) D-1.938 USE KIT 5-281X, 5-676X								
FOR HR STYLE USE STRAP KIT 6.5-70-18X								
2.794-54 Involute Spline								
2.794	—	2.750	5.625	—	BP			6.5-4-4631 <i>Hub diameter not ground.</i>
2.794	—	2.750	5.625	—	HR			6.5-4-4631-1 <i>Hub diameter not ground.</i>
2.795-55 Involute Spline								
2.795	4.719	2.047	5.000	.150	HR			6.5-4-4521-1•
2.798-21 Involute Spline								
2.798	3.531	2.094	4.844	.080	HR			6.5-4-3941-1
2.922-22 Involute Spline								
2.922	3.875	2.625	5.375	—	BP			6.5-4-3081
3.003-23 Involute Spline								
3.003	4.000	3.000	5.750	.310	BP	6.5-4-4401X	232193	6.5-4-2621
3.003	4.000	3.000	5.750	.310	HR	6.5-4-4401-1X	232193	6.5-4-2621-1▲
3.045-48 Involute Spline								
3.045	4.250	1.955	4.882	—	HR			5005680
3.100-60 Involute Spline								
3.100	4.000	2.500	5.312	—	BP			6.5-4-2681
1880 SERIES E-8.094 D-2.188 USE KIT 5-308X								
2.625-20 Involute Spline								
2.625	4.500	3.910	7.470	1.160	BP			8-4-791•
2.794-54 Involute Spline								
2.794	3.625	2.315	5.250	.120	BP	8-4-1351X	232746	8-4-1341▲
3.582-59 Involute Spline								
3.582	4.725	4.406	8.000	—	BP	8-4-1381X•	233038	8-4-1321▲
3.582	4.725	4.411	8.000	—	BP	5002688•	233038	5002687▲
1950 SERIES E-10.047 D-3.062 USE KIT 5-192X								
USES CAP & BOLT ASSY. 9-70-18X								
3.500-27 Involute Spline								
3.500	5.000	4.219	7.844	—	CB	9-4-311X•	230922	9-4-301▲

• Part is discontinued ■ Part is available until supply is exhausted ▲ Not sold separately



END YOKES with SPLINED HOLES



Major Diameter	R	Q	S	C'Bore Depth	Style	End Yoke Assy. (includes slinger/plug) Order When Listed	Slinger/Plug Part Number	Spicer Part Number
	Ground Hub Dia.	Length Thru Hole	Centerline to End					
4C SERIES			WB STYLE P-4.250 T-1.438 KEYWAY .375			USE KIT 5-4143X		
1.450-27 Involute Spline								
1.450	2.250	1.235	2.695	—	WB		4C-4-11	Tapped holes in yoke ears
1.605-15 Involute Spline								
1.605	2.125	1.938	2.840	—	WB		4C-4-21	Tapped holes in yoke ears
1.605	2.125	1.938	2.840	—	WB		4C-4-31	Tapped holes in yoke ears
1.605	2.125	1.938	3.135	—	WB		4C-4-41	Tapped holes in yoke ears
5C SERIES			P-4.530 T-1.688 KEYWAY: 0.561			USE KIT 5C-1X		
1.450-27 Involute Spline								
1.450	2.250	2.060	3.000	.250	WB		5C-4-41	Tapped holes in yoke ears
1.450	2.250	2.060	3.375	.250	WB		5C-4-91	Flanged WB yoke w/tapped holes in yoke ears
1.605-15 Involute Spline								
1.605	2.125	1.938	2.820	—	WB		5C-4-51	Tapped holes in yoke ears
1.605	2.125	1.938	3.038	—	WB		5C-4-101	Flanged WB yoke w/tapped holes in yoke ears
1.605	2.125	1.938	3.500	—	WB		5C-4-61	Tapped holes in yoke ears
1.605	2.125	1.938	3.500	—	WB		5C-4-71M	Metric; Tapped holes in yoke ears
1.922-14 Involute Spline								
1.922	2.375	2.182	3.750	—	WB		5C-4-111	Flanged WB yoke w/tapped holes in yoke ears
6C SERIES			P-5.530 T-1.688 KEYWAY: 0.561			USE KIT 050138000		
1.450-27 Involute Spline								
1.450	2.250	2.062	4.250	.250	WB		6C-4-31	Flanged WB yoke w/tapped holes in yoke ears
1.450	2.250	2.062	3.000	.250	WB		6C-4-61	Tapped holes in yoke ears
1.605-15 Involute Spline								
1.605	2.125	1.937	3.055	—	WB		6C-4-191	Flanged WB yoke w/tapped holes in yoke ears
1.605	2.125	1.937	3.090	—	WB		6C-4-71	Tapped holes in yoke ears
1.650-16 Involute Spline								
1.650	2.375	2.000	3.062	—	WB		6C-4-91	Tapped holes in yoke ears
1.922-14 Involute Spline								
1.922	2.375	2.183	3.500	—	WB		6C-4-141	Tapped holes in yoke ears
1.922	2.375	2.183	3.750	—	WB		6C-4-201	Flanged WB yoke w/tapped holes in yoke ears
1.922	2.375	2.188	3.122	.120	WB		6C-4-81	Tapped holes in yoke ears
2.005-15 Involute Spline								
2.005	2.875	2.500	3.880	.250	WB		6C-4-101	Tapped holes in yoke ears
2.005	2.875	2.500	3.880	.250	WB		6C-4-111	Tapped holes in yoke ears
2.289-17 Involute Spline								
2.289	2.750	2.500	3.810	—	WB		6C-4-251	Tapped holes in yoke ears

• Part is discontinued ■ Part is available until supply is exhausted ▲ Not sold separately



Important: See Safety Information in General Information Section (J300P-GI)

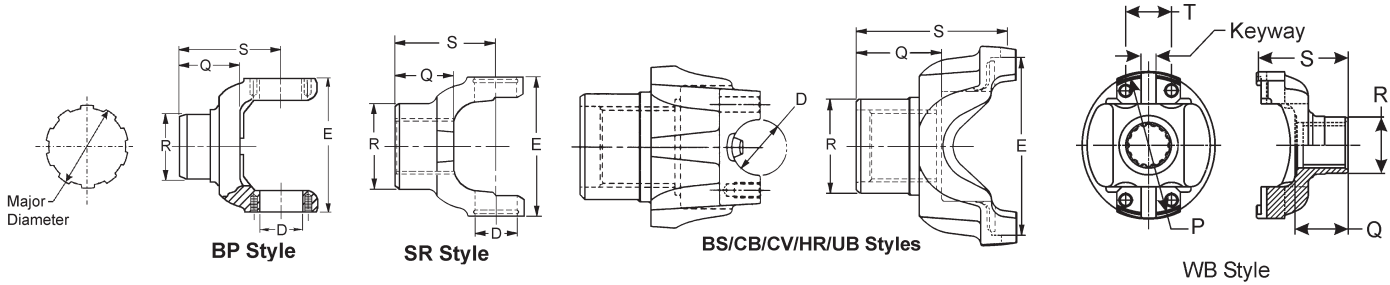

Major Diameter	R	Q	S	C'Bore Depth	Style	End Yoke Assy. (includes slinger/plug) Order When Listed	Slinger/Plug Part Number	Spicer Part Number
	Ground Hub Dia.	Length Thru Hole	Centerline to End					
6C SERIES (Con't)			P-5.530	T-1.688	KEYWAY: 0.561		USE KIT 050138000	
2.289-17 Involute Spline (Continued)								
2.289	2.750	2.500	4.250	—	WB		6C-4-261	Flanged yoke w/8 tapped holes in flange
2.541-19 Involute Spline								
2.541	3.125	3.125	4.589	.250	WB		6C-4-41	Tapped holes in yoke ears
7C SERIES			P-5.842	T-1.938	KEYWAY: 0.624		USE KIT 5-7105X	
1.605-15 Involute Spline								
1.605	2.125	1.938	3.620	—	WB		7C-4-81	Tapped holes in yoke ears
1.650-16 Involute Spline								
1.650	2.375	2.000	3.780	—	WB		7C-4-211	Flanged yoke w/6 drilled holes in flange
1.650	2.375	2.000	3.250	.380	WB		7C-4-261	Tapped holes in yoke ears
1.775-16 Involute Spline								
1.775	2.625	2.250	3.500	—	WB		7C-4-121	Tapped holes in yoke ears
1.775	2.625	2.250	3.500	—	WB		7C-4-201	Flanged yoke w/six, tapped holes in flange
1.796-34 Involute Spline								
1.796	2.625	2.094	3.520	.200	WB		7C-4-291	Tapped holes in yoke ears
1.922-14 Involute Spline								
1.922	2.375	2.188	3.440	.120	WB		7C-4-131	Tapped holes in yoke ears
1.922	2.375	2.188	3.690	.120	WB		7C-4-311	Tapped holes in yoke ears
1.922	2.375	2.188	3.690	.120	WB		7C-4-141	Tapped holes in yoke ears
1.922	2.375	2.188	3.690	.120	WB		7C-4-151M	Metric; Tapped holes in yoke ears
1.922	2.375	2.188	3.690	.120	WB		7C-4-71	Tapped holes in yoke ears
1.922	2.375	2.188	3.750	—	WB		7C-4-251	Tapped holes in yoke ears; w/6 tapped holes in flange
1.922	2.375	2.188	4.440	—	WB		7C-4-241	Flanged yoke w/8 tapped holes in flange
2.005-15 Involute Spline								
2.005	2.822	2.500	3.880	.250	WB		7C-4-281M	Metric; Tapped holes in yoke ears
2.005	2.822	2.500	3.880	.250	WB		7C-4-31	Tapped holes in yoke ears
2.005	2.822	2.500	3.880	.250	WB		7C-4-41M	Metric; Tapped holes in yoke ears

• Part is discontinued ■ Part is available until supply is exhausted ▲ Not sold separately



END YOKES with SPLINED HOLES



Major Diameter	R	Q	S	C'Bore Depth	Style	End Yoke Assy. (includes slinger/plug) Order When Listed	Slinger/Plug Part Number	Spicer Part Number
	Ground Hub Dia.	Length Thru Hole	Centerline to End					
7C SERIES (Con't)				P-5.842	T-1.938	KEYWAY: 0.624	USE KIT 5-7105X	
2.005-15 Involute Spline (Continued)								
2.005	2.875	2.500	4.880	.250	WB			7C-4-191
							<i>Tapped holes in yoke ears; w/16 tapped holes in flange</i>	
2.005	2.875	2.500	3.880	.250	WB			7C-4-11
							<i>Tapped holes in yoke ears</i>	
2.005	2.875	2.500	3.880	.250	WB			7C-4-271
							<i>Tapped holes in yoke ears</i>	
2.005	2.875	2.500	4.880	.250	WB			7C-4-351
							<i>Tapped holes in yoke ears; w/16 tapped holes in flange</i>	
2.008-31 Involute Spline								
2.008	—	2.750	4.209	.750	WB			7C-4-471M
							<i>Metric; Tapped holes in yoke ears; Hub dia. not ground</i>	
2.289-17 Involute Spline								
2.289	2.750	2.500	4.190	—	WB			7C-4-101
							<i>Tapped holes in yoke ears</i>	
2.289	2.750	2.500	4.190	—	WB			7C-4-111M
							<i>Metric; Tapped holes in yoke ears</i>	
2.289	2.750	2.500	4.190	—	WB			7C-4-91
							<i>Tapped holes in yoke ears</i>	
2.289	2.750	2.500	4.440	—	WB			7C-4-161
							<i>Flanged WB yoke w/tapped holes in yoke ears</i>	
2.289	2.750	2.500	4.440	—	WB			7C-4-321
							<i>Flanged WB yoke w/tapped holes in yoke ears</i>	
2.372-46 Involute Spline								
2.372	—	3.385	4.705	.500	WB			7C-4-401M
							<i>Metric; Tapped holes in yoke ears</i>	
2.447-28 Involute Spline								
2.447	3.375	2.500	4.750	.250	WB			7C-4-171
							<i>Tapped holes in yoke ears; Flanged yoke w/8 drilled holes in</i>	
2.541-19 Involute Spline								
2.541	3.125	3.120	4.590	—	WB			7C-4-61
							<i>Tapped holes in yoke ears</i>	
8C SERIES				P-8.125	T-1.938	KEYWAY: 0.624	USE KIT 5-8105X	
2.447-28 Involute Spline								
2.447	3.375	2.500	4.750	.250	WB			8C-4-101
							<i>Flanged WB yoke w/tapped holes in yoke ears</i>	
2.541-19 Involute Spline								
2.541	3.125	3.125	4.590	.250	WB			8C-4-51
							<i>Tapped holes in yoke ears</i>	
8.5C SERIES				P-6.500	T-2.812	KEYWAY: 0.625	USE KIT NO. 050246000, 050281000	
1.922-14 Involute Spline								
1.922	2.375	2.182	3.440	.120	WB			8.5C-4-21
							<i>Tapped holes in yoke ears</i>	
1.922	2.375	2.182	4.120	.120	WB			8.5C-4-41
							<i>Tapped holes in yoke ears</i>	
1.922	2.375	2.182	4.120	.120	WB			8.5C-4-71
							<i>Tapped holes in yoke ears</i>	
2.005-15 Involute Spline								
2.005	2.625	2.188	3.440	—	WB			8.5C-4-51
							<i>Tapped holes in yoke ears</i>	
2.289-17 Involute Spline								
2.289	2.750	2.500	4.440	—	WB			8.5C-4-61
							<i>Tapped holes in yoke ears</i>	
2.364-36 Involute Spline								
2.364	—	2.500	4.410	.310	WB			5003634
							<i>Tapped holes in yoke ears; Hub diameter not ground</i>	

• Part is discontinued ■ Part is available until supply is exhausted ▲ Not sold separately



Important: See Safety Information in General Information Section (J300P-GI)

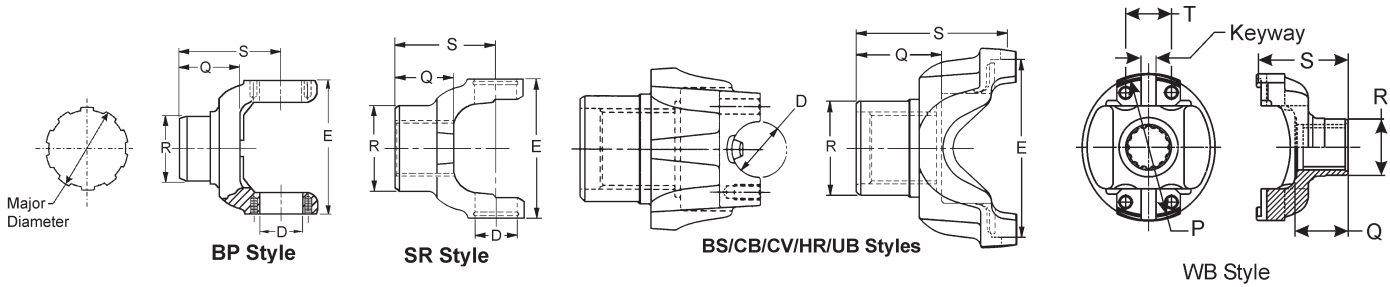

Major Diameter	R	Q	S	C'Bore Depth	Style	End Yoke Assy. (includes slinger/plug) Order When Listed	Slinger/Plug Part Number	Spicer Part Number
	Ground Hub Dia.	Length Thru Hole	Centerline to End					
8.5C SERIES (Con't) P-6.500 T-2.812 KEYWAY:0.625 USE KIT NO. 050246000, 050281000								
2.447-28 Involute Spline								
2.447	3.375	2.500	4.750	.250	WB			8.5C-4-11 <i>Tapped holes in yoke ears</i>
2.447	3.375	2.500	4.750	.250	WB			8.5C-4-111 <i>Flanged WB yoke w/tapped holes in yoke ears</i>
2.541-19 Involute Spline								
2.541	3.125	3.125	4.590	.250	WB			8.5C-4-31 <i>Tapped holes in yoke ears</i>
2.588-40 Involute Spline								
2.588	4.000	2.840	4.070	—	WB	5004773	5001687	5004772 ▲ <i>Metric; Tapped holes in yoke ears</i>
9C/1820 SERIES P-8.250 S-2.812 KEYWAY: 0.624 USE KIT 5-9001X								
2.005-15 Involute Spline								
2.005	2.875	2.500	3.880	.250	WB			9C-4-41• <i>Drilled holes in yoke ears</i>
2.344-16 Spline								
2.344	2.875	2.750	4.125	—	WB			8-4-851
2.375-46 Involute Spline								
2.375	3.750	2.375	3.938	—	WB	8-4-1151X <i>Assy includes mechanical speedometer drive gear #231527</i>		8-4-1141•
2.375	3.750	2.375	3.938	—	WB	8-4-1161X <i>Assy includes electronic speedometer gear #231528</i>		8-4-1141•
2.500-10 Spline								
2.500	3.500	3.234	4.375	—	WB			8-4-1061
2.541-19 Involute Spline								
2.541	3.125	3.125	4.590	.250	WB			9C-4-91
2.541	3.125	3.125	5.250	—	WB			9C-4-111 <i>Tapped holes in yoke ears</i>
2.631-25 Involute Spline								
2.631	3.875	4.312	6.810	1.120	WB			9C-4-211• <i>Tapped holes in yoke ears</i>
2.784-21 Involute Spline								
2.784	3.375	3.125	4.590	—	WB			9C-4-81
10C SERIES P-8.375 S-3.625 KEYWAY: 1.000 USE KIT 050242000, 050A53000								
2.631-25 Involute Spline								
2.631	3.625	3.000	4.620	1.000	WB			10C-4-211■ <i>Tapped holes in yoke ears</i>
3.923-30 Involute Spline								
3.923	4.875	4.625	6.240	—	WB			10C-4-81

• Part is discontinued ■ Part is available until supply is exhausted ▲ Not sold separately



END YOKES with SPLINED HOLES



Major Diameter	R	Q	S	C'Bore Depth	Style	End Yoke Assy. (includes slinger/plug) Order When Listed	Slinger/Plug Part Number	Spicer Part Number
	Ground Hub Dia.	Length Thru Hole	Centerline to End					
7290 SERIES			K-2.625	D-1.125	USE KIT NO. 5-1309X, 5-354X, 5-811X			
1.146-26 Involute Spline								
1.146	1.552	1.500	3.350	—	BS	2-4-7651-1X■	232549	2-4-7641-1▲
1.146	1.844	1.375	3.219	.120	BS			2-4-7661-1
1.263-29 Involute Spline								
1.263	1.875	1.500	3.188	—	BS			2-4-7901-1
1.276-29 Involute Spline								
1.276	1.875	1.500	3.359	—	BS	2-4-7681-1X	34592	2-4-7671-1▲

• Part is discontinued ■ Part is available until supply is exhausted ▲ Not sold separately



Important: See Safety Information in General Information Section (J300P-GI)

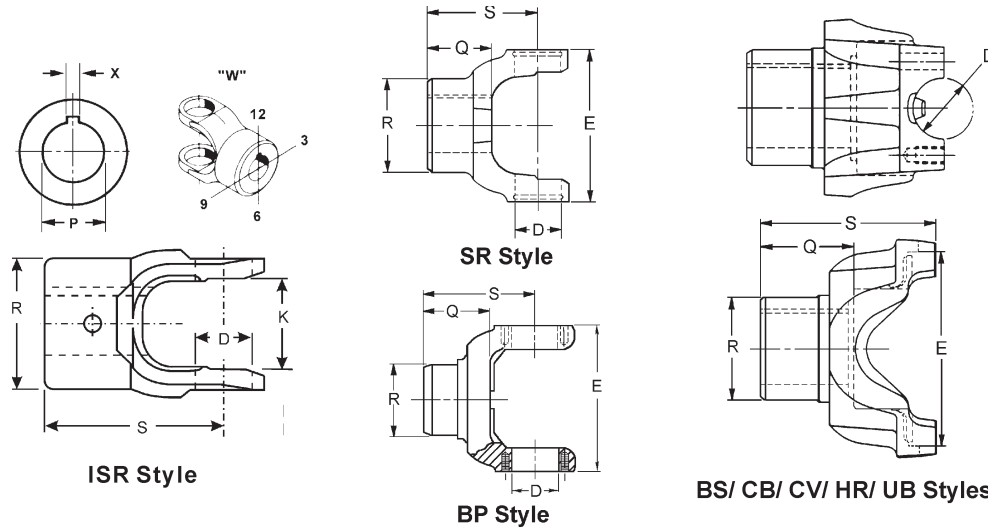

P Round Hole Diameter	X SAE Keyway Width	W Set Screw Location in Relation to Keyway			R Hub Diameter	Q Length Thru Hole	S C/L to End of Hub	S T Y L E	End Yoke Part Number
		Hole Diameter	Location						
			Keyway	Set Screw					
1000 SERIES		K-1.500		D-.938	USE KIT 5-170X				
.625	—	—			1.625	1.030	2.500	ISR	10-4-333 <i>High angle yoke</i>
.625	.188	.375	12	6	1.625	—	2.500	ISR	10-4-373 <i>High angle yoke</i>
.750	—	—			1.624	—	2.500	ISR	10-4-303 <i>High angle yoke</i>
.750	.188	.375	12	9	1.625	1.312	1.812	ISR	10-4-693
.750	.188	.375	3	6	1.625	1.030	2.500	ISR	10-4-13 <i>High angle yoke</i>
.750	.188	.375	3	6 & 12	1.625	1.030	2.500	ISR	10-4-133 <i>High angle yoke</i>
.750	.250	.375	3	9	1.625	1.030	2.500	ISR	10-4-23 <i>High angle yoke</i>
.812	.188	.375	3	9	1.625	1.030	2.500	ISR	10-4-33* <i>High angle yoke</i>
.812	.250	.375	12	9	1.625	1.312	1.812	ISR	10-4-713
.812	.250	.375	3	6	1.625	1.030	2.500	ISR	10-4-43 <i>High angle yoke</i>
.875	—	.375		3	1.625	—	2.500	ISR	10-4-203 <i>High angle yoke</i>
.875	.188	.375	3	9	1.625	1.030	2.500	ISR	10-4-53 <i>High angle yoke</i>
.875	.250	.375	3	9	1.625	—	2.500	ISR	10-4-453 <i>High angle yoke</i>
.875	.250	.375	3	9	1.625	—	2.500	ISR	10-4-63 <i>High angle yoke</i>
.938	.250	.375	3	9	1.625	—	2.500	ISR	10-4-73 <i>High angle yoke</i>
1.000	—	—			1.625	1.030	2.500	ISR	10-4-443 <i>High angle yoke; .375 dia. drilled hole thru hub</i>
1.000	.188	.375	3	9	1.625	1.030	2.500	ISR	10-4-83 <i>High angle yoke</i>
1.000	.250	.375	3	12	1.625	1.030	2.500	ISR	10-4-573 <i>High angle yoke</i>
1.000	.250	.375	3	9	2.000	1.030	2.500	ISR	10-4-93 <i>High angle yoke</i>

• Part is discontinued ■ Part is available until supply is exhausted ▲ Not sold separately



STRAIGHT ROUND HOLE

P Round Hole Diameter	X SAE Keyway Width	W Set Screw Location in Relation to Keyway			R Hub Diameter	Q Length Thru Hole	S C/L to End of Hub	S T Y L E	End Yoke Part Number
		Hole Diameter	Location						
			Keyway	Set Screw					
1000 SERIES (Continued)		K-1.500 D-.938			USE KIT 5-170X				
1.062	.250	.375	9	6	2.000	1.030	2.500	ISR	10-4-163 <i>High angle yoke</i>
1.125	.250	.375	3	12	2.000	1.030	2.500	ISR	10-4-143 <i>High angle yoke</i>
1.125	.250	.375	3	6	2.000	1.030	2.500	ISR	10-4-103 <i>High angle yoke</i>
1.125	.312	.375	3	6	2.000	1.030	2.500	ISR	10-4-1473 <i>High angle yoke</i>
1.125	.312	.375	3	9	2.000	1.030	2.500	ISR	10-4-113 <i>High angle yoke</i>
1.125	.312	.375	3	9	2.000	1.030	2.500	ISR	10-4-233 <i>High angle yoke</i>
1.188	.312	.375	3	9	2.000	1.030	2.500	ISR	10-4-153 <i>High angle yoke</i>
1.250	.250	.375	9	12	2.000	1.030	2.500	ISR	10-4-183 <i>High angle yoke</i>
1.250	.312	.375	3	9	2.000	1.030	2.500	ISR	10-4-123 <i>High angle yoke</i>
1.250	.312	.375	9	12	2.000	—	2.500	ISR	10-4-193 <i>High angle yoke</i>
1.375	.312	.375	3	9	2.000	1.030	2.500	ISR	10-4-293 <i>High angle yoke</i>
1.375	.375	.375	3	6	2.250	—	2.500	ISR	10-4-213 <i>High angle yoke</i>
1.438	.375	.375	3	9	2.250	—	2.500	ISR	10-4-383 <i>High angle yoke</i>
1.500	.375	.375	3	6	2.250	—	2.500	ISR	10-4-223 <i>High angle yoke</i>
1110 SERIES		K-2.656 D-.938			USE KIT NO. 5-101X				
.750	.188	.375	12	3	1.688	—	2.250	SR	1-4-783
.750	.188	.375	12	6	1.688	—	2.250	SR	1-4-1383•
.875	.188	.375	9	3	2.000	—	2.250	SR	1-4-803
1.000	.250	.375	9	3	2.000	—	2.250	SR	1-4-823
1.125	.312	.375	3	9	2.000	—	2.250	SR	1-4-943
1.250	.250	.375	3	6	2.000	—	2.250	SR	1-4-1133
1.250	.312	.375	3	9	2.000	—	2.250	SR	1-4-933
1140 SERIES		K-1.812 D-1.062			USE KIT NO. 5-242X				
1.125	.250	.375	12	—	—	—	—	SR	1-4-3043•
1.250	.250	.375	12	—	—	—	—	SR	1-4-3093•
1.250	.312	.375	12	—	—	—	—	SR	1-4-3113•
1.375	.312	.375	9	—	—	—	—	SR	1-4-3133•
1240 SERIES		E-2.875 D-1.125			USE KIT NO 5-129X				
1.125	.250	.375	12	—	—	—	—	SR	2-4-1363•
1.250	.250	.375	12	—	—	—	—	SR	2-4-1413•
1.250	.312	.375	12	—	—	—	—	SR	2-4-1423•
1.375	.312	.375	12	—	—	—	—	SR	2-4-1873•
1.500	.375	.375	9	—	—	—	—	SR	2-4-1463•

• Part is discontinued ■ Part is available until supply is exhausted ▲ Not sold separately



Important: See Safety Information in General Information Section (J300P-GI)

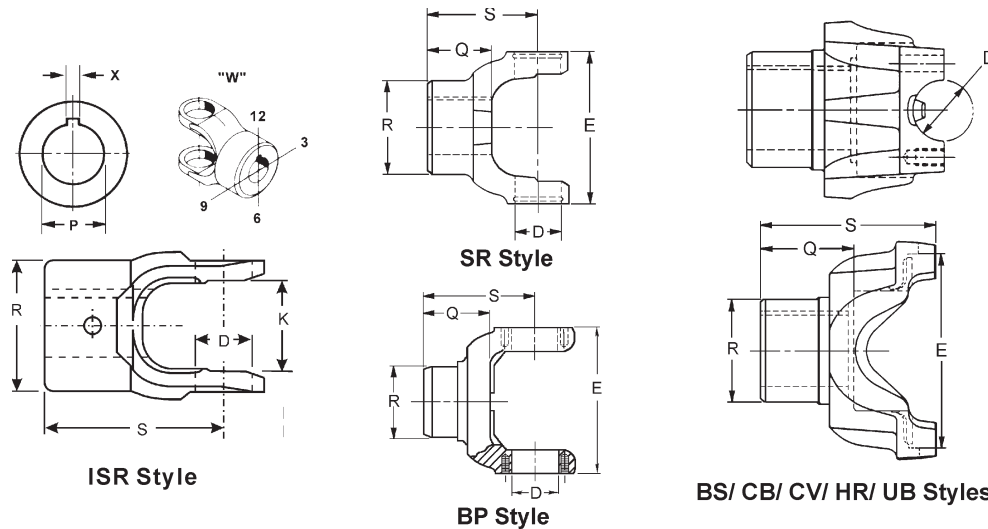

P Round Hole Diameter	X SAE Keyway Width	W Set Screw Location in Relation to Keyway			R Hub Diameter	Q Length Thru Hole	S C/L to End of Hub	S T Y L E	End Yoke Part Number
		Hole Diameter	Location						
			Keyway	Set Screw					
1310 SERIES SR: E-3.469 OTHERS E-3.219, D-1.062					USE KIT 5-153X,5-785X,5-810X				
.750	—	—			2.125	—	2.562	SR	2-4-177
.750	.188	.375	12	6	2.125	—	2.562	SR	2-4-433
.812	.250	.375	12	6	2.125	—	2.562	SR	2-4-443
.875	.188	.375	12	6	2.125	—	2.562	SR	2-4-453
.875	.250	.375	12	6	2.125	—	2.562	SR	2-4-583
.938	.250	.375	12	6	2.000	—	2.562	SR	2-4-463
1.000	.250	.375	12	6 & 12	2.125	—	2.562	SR	2-4-473
1.125	.250	.375	12	6	2.125	—	2.562	SR	2-4-503
1.125	.312	.375	12	6	2.125	—	2.562	SR	2-4-523
1.188	.312	.375	12	6	2.125	—	2.562	SR	2-4-553
1.250	—	—			2.125	—	2.562	SR	2-4-853
1.250	—	.375			2.120	—	2.562		2-4-2043
1.250	.250	.375	12	6	2.125	—	2.562	SR	2-4-573
1.250	.312	.375	12		2.125	—	2.561	SR	2-4-613
1.250	.312	.375	12	6	2.125	—	2.562	SR	2-4-533
1.250	.312	.375	12	6, 9, 12	2.125	—	2.562	SR	2-4-2613
1.250	.312	.500	12	6	2.125	—	2.562	SR	2-4-663
1.250	.313	.375	12	6	2.120	—	2.940	UB	2-4-783•
1.250	.314	.375	12	6	2.120	1.495	2.935	SR	2-4-783-1
1.375	.312	.375	12	3	2.000	—	2.562	SR	2-4-1103
1.375	.375	.375	12	6	2.125	1.125	2.594	UB	2-4-1053
1.375	.375	.375	12	6	2.000	—	2.562	SR	2-4-803
1.500	.375	.375	12	6	2.125	—	2.562	SR	2-4-1233
1.503	—	—			2.000	1.625	2.562	SR	2-4-353
1.688	.375	.375	12	12	2.500	—	2.562	SR	2-4-2013
1340 SERIES E-3.953 D-1.250					USE KIT NO. 5-243X				
1.375	.312	.375	12	12 & 3	—	—	—	SR	3-4-813•
1350 SERIES SR: E-3.875 OTHERS: E-3.625, D-1.188					USE KIT 5-178X, 5-799X				
.750	—	—			2.000	—	4.090	BS	3-4-543-1
1.000	.250	—	12		2.000	—	2.690	SR	3-4-33

• Part is discontinued ■ Part is available until supply is exhausted ▲ Not sold separately



STRAIGHT ROUND HOLE



P Round Hole Diameter	X SAE Keyway Width	W Set Screw Location in Relation to Keyway			R Hub Diameter	Q Length Thru Hole	S C/L to End of Hub	S T Y L E	End Yoke Part Number
		Hole Diameter	Location						
			Keyway	Set Screw					
1350 SERIES (Con't)		SR: E-3.875 OTHERS: E-3.625, D-1.188			USE KIT 5-178X, 5-799X				
1.125	.250	—	12		2.000	—	2.688	SR	3-4-43
1.250	.312	—	12		2.000	—	2.750	SR	3-4-53
1.250	.312	—	12		2.000	—	2.688	SR	3-4-93
1.250	.312	.375	12		2.000	—	2.750	SR	3-4-13
							<i>Two set screws, 135° & 225° from keyway</i>		
1.250	.312	.375	12	6	2.062	—	3.000	SR	3-4-103
1.250	.314	.375	12	6	2.250	1.500	3.000	BS	3-4-283-1
1.375	.312	.375	12	6	2.250	1.500	3.031	BS	3-4-613-1
1.500	.313	.375	12		—	—	3.500	BS	3-4-243-1
1.500	.375	.375	12	6	—	—	3.469	BS	3-4-333-1
1410 SERIES		SR: E-4.438 OTHERS: E-4.188, D-1.188			USE KIT 5-160X, 5-801X				
1.250	.250	.500	12	6	2.250	—	3.700	BS	3-4-163-1
1.250	.312	.375	12	6	2.250	2.000	3.688	BS	3-4-343-1
1.250	.313	—	12		2.250	2.000	3.700	UB	3-4-1763•
1.250	.313	—	12		2.252	2.000	3.700	BS	3-4-1763-1
1.500	.377	.500	12	135°	2.690	2.270	4.000	BS	3-4-263-1
							<i>Two set screws, 135° & 225° from keyway</i>		
1.750	.439	.500	12		2.750	—	4.250	BS	3-4-273-1
							<i>Two set screws, 135° & 225° from keyway</i>		
1480 SERIES		SR: E-4.438 OTHERS: E-4.188, D-1.375			USE KIT 5-188X, 5-803X				
1.375	—	—			2.130	—	1.440		3-4-1743•
1.500	.375	.375	12	12 & 6	3.188	2.063	4.625	SR	3-4-1173•
							<i>.318 dia. hole drilled thru hub</i>		
2.000	.500	.375	3	3 & 9	3.188	2.063	4.625	SR	3-4-1753•
							<i>.318 dia. hole drilled thru hub</i>		
1550 SERIES		E-5.250 D-1.375			USE KIT 5-155X, 5-808X				
1.862	—	—			3.070	2.625	4.685	BS	4-4-843-1
1610 SERIES		E-5.312 D-1.875			USE KIT 5-279X, 5-674X				
1.750	—	—			2.750	—	5.620	BP	5-4-413
							<i>High angle yoke</i>		
2.250	—	—			3.344	—	5.620	BP	5-4-453•
							<i>High angle yoke</i>		

• Part is discontinued ■ Part is available until supply is exhausted ▲ Not sold separately



Important: See Safety Information in General Information Section (J300P-GI)

TAPERED HOLE With U-Bolt and Cap & Bolt Design

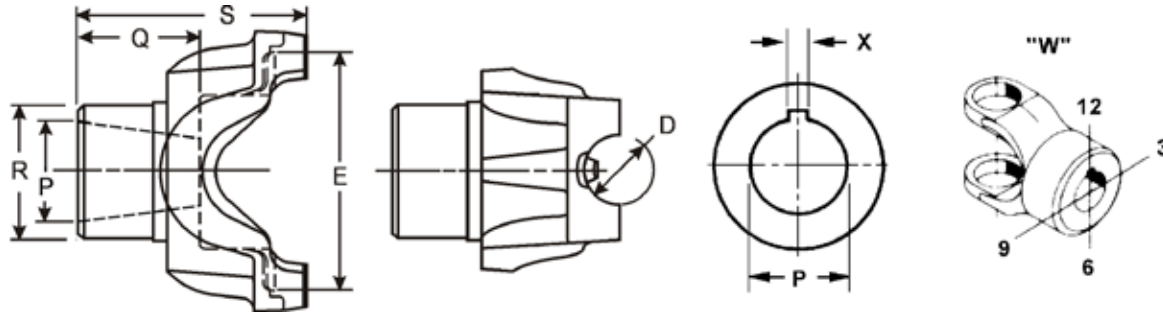

P	X	R	Q	S	S T Y L E	End Yoke Part Number
Tapered Hole Diameter (large dia.)	SAE Keyway Width	Ground Hub Diameter	Length Thru Hole	Centerline to End of Spline		
1310 SERIES SR: E-3.469 OTHERS E-3.219, D-1.062					=USE KIT 5-153X,5-785X,5-810X	
USES U-BOLT ASSY. 2-94-28X, STRAP ASSY. 2-70-18X						
1.125	.312	1.750	1.500	3.000	UB	2-4-154•
1.250	.312	2.125	1.500	2.938	UB	2-4-64
1.375	.375	2.125	2.000	3.438	UB	2-4-824
1.375	.375	2.250	2.000	3.438	UB	2-4-834
1.496	.375	2.200	2.000	3.450	BS	2-4-854•
1350 SERIES SR: E-3.875 OTHERS: E-3.625, D-1.188					USE KIT 5-178X, 5-799X	
USES U-BOLT ASSY. 3-94-18X, STRAP ASSY. 3-70-28X						
1.246	.312	2.250	1.500	3.000	BS	3-4-54-1
1.250	.314	2.620	1.475	3.250	BS	3-4-234-1•
1.375	.375	2.250	2.000	3.531	BS	3-4-24-1
1.496	.375	2.250	2.000	3.500	BS	3-4-84-1
1410 SERIES SR: E-4.438 OTHERS: E-4.188, D-1.188					USE KIT 5-160X, 5-801X	
USES U-BOLT ASSY, 3-94-18X, STRAP KIT 3-70-28X						
1.375	.375	2.250	2.000	3.688	BS	3-4-14-1
1.375	.375	2.250	2.000	3.688	BS	3-4-154-1
1.496	.375	2.500	2.000	3.812	BS	3-4-64-1
1650 SERIES E-5.594 D-1.625					USE KIT 5-165X	
USES CAP & BOLT ASSY. 5-70-18X						
1.750	.438	2.875	2.250	4.312	BS	5-4-1324

• Part is discontinued ■ Part is available until supply is exhausted ▲ Not sold separately



HEX & SQUARE HOLE

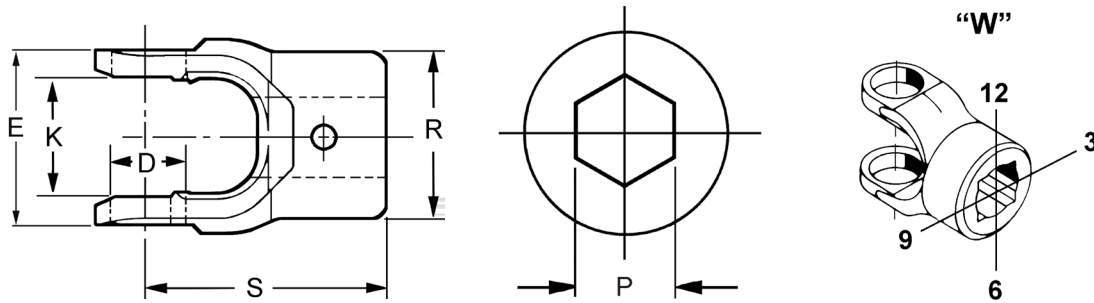

P Hex Hole Diameter	R Ground Hub Diameter	W Set Screw Hole Viewed from Hub End		S Centerline to End of Hub	End Yoke Part Number
		Hole Diameter	Location		
1000 SERIES					
		K-1.500	D-.938	USE KIT 5-170X	
.875	2.000	.375	3	2.500	10-4-282
1.125	2.000	.375	3	2.500	10-4-32

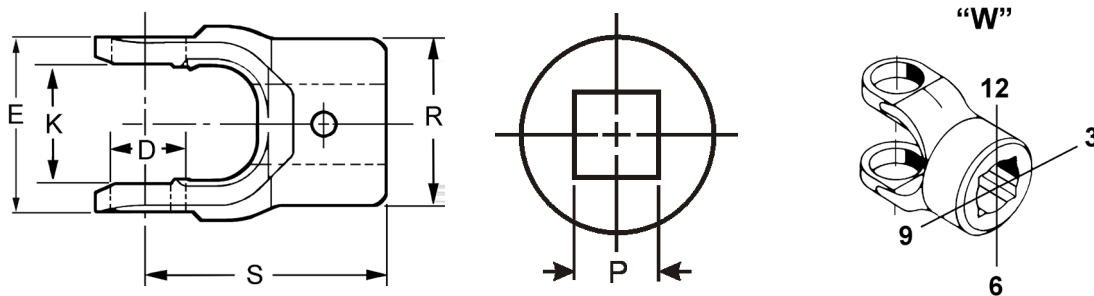

P Hex Hole Diameter	R Ground Hub Diameter	W Set Screw Hole Viewed from Hub End		S Centerline to End of Hub	End Yoke Part Number
		Hole Diameter	Location		
1000 SERIES					
		K-1.500	D-.938	USE KIT 5-170X	
.750	1.625	.375	3	2.500	10-4-22
.812	1.969	.375	3	2.500	10-4-42
.875	1.620	.375	3	2.875	10-4-62
.875	1.719	—	—	2.500	10-4-82
<i>10-4-82 will be replaced by 10-4-92 when supply is exhausted</i>					
.875	1.969	.375	3	2.500	10-4-12
1.000	2.000	.375	3	2.500	10-4-52
1140 SERIES					
		K-1.812	D-1.062	USE KIT NO. 5-242X	
1.000	—	.375	—	—	1-4-222•
1240 SERIES					
		E-2.875	D-1.125	USE KIT NO 5-129X	
1.000	—	—	—	—	2-4-152•
1310 SERIES SR: E-3.469 OTHERS E-3.219, D-1.062 USE KIT 5-153X,5-785X,5-810X					
.875	2.120	—	—	2.560	2-4-502▪

• Part is discontinued ■ Part is available until supply is exhausted ▲ Not sold separately



Important: See Safety Information in General Information Section (J300P-GI)

STEERING SHAFT SERRATED HOLE With Snap Ring Design

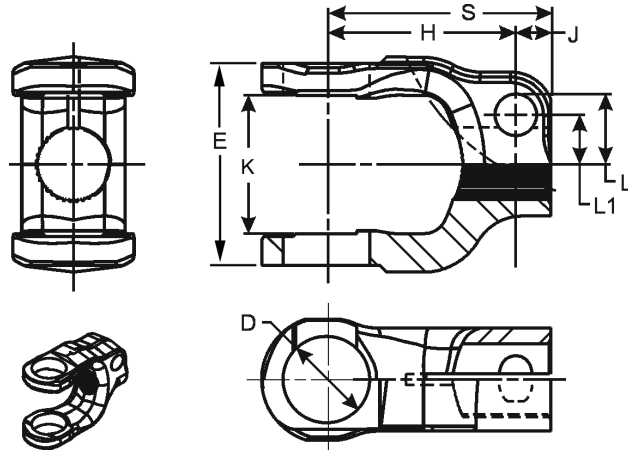

Serrated Hole		Bolt Hole Diameter	H	J	L	L1	S	End Yoke Part Number
Major Diameter	Minor Diameter (Nominal)		Center of Bolt Hole to Center of Bearing Hole	Center of Bolt Hole to End of Hub	Top of Bolt Hole to Center of Spline	Center of Bolt Hole to Center of Spline	Centerline to End of Hub	
1000 SERIES		K-1.500	D-.938					USE KIT 5-103X
.735-16 Based On 36 Spline								
.735	.696	.451	2.120	.500	—	.525	2.620	10-4-431SX
.739-21 Based On 36 Spline								
.739	.696	.467	1.780	.470	.748	—	2.250	10-4-871SX
.739-26 Based On 36 Spline								
.739	.696	.467	1.780	.470	.726	.525	2.250	10-4-611SX
.739-30 Based On 36 Spline								
.739	.696	.406	2.030	.470	—	.470	2.500	10-4-631SX
.739	.696	.406	2.030	.470	—	.470	2.500	10-4-931SX
.811-30 Based On 36 Spline								
.811	.764	.405	2.030	.470	.710	—	2.500	10-4-501SX
.811	.764	.405	2.120	.500	.710	—	2.620	10-4-901SX
.811	.764	.406	2.030	.470	.673	—	2.700	10-4-491SX
.811	.764	.467	2.030	.470	.770	—	2.500	10-4-1001SX
.811	.764	.467	2.030	.470	.770	—	2.500	10-4-821SX
.811	.764	.470	2.030	.380	.770	—	2.410	10-4-1181SX*
.813-18 Based On 36 Spline								
.813	.764	.451	2.030	.380	.764	—	2.410	10-4-911SX
.813	.764	.451	2.030	.470	.759	—	2.500	10-4-841SX
.813	.764	.467	1.780	.380	.761	—	2.160	10-4-621SX
.813	.764	.467	1.780	.470	.762	—	2.250	10-4-1281SX*
.813	.764	.467	2.330	.370	.761	—	2.700	10-4-551SX
.870-14 Based On 36 Spline								
.870	.819	.451	2.031	.470	.781	—	2.500	10-4-1061SX
.870-30 Based On 36 Spline								
.870	.819	.403	2.031	.469	.748	—	2.500	10-4-601SX
.870	.819	.405	2.031	.469	.738	—	2.500	10-4-951SX
.870	.819	.451	2.031	.530	.789	—	2.280	10-4-1241SX*
.870	.819	.467	2.031	.469	.815	—	2.500	10-4-741SX
.870	.819	.467	2.031	.470	.780	—	2.500	10-4-991SX*
.870	.819	.467	2.031	.470	.787	—	2.500	10-4-461SX
.990-14 Based On 36 Spline								
.990	.947	.451	2.030	.470	.852	—	2.500	10-4-851SX

• Part is discontinued ■ Part is available until supply is exhausted ▲ Not sold separately



STEERING SHAFT SERRATED HOLE With Snap Ring Design

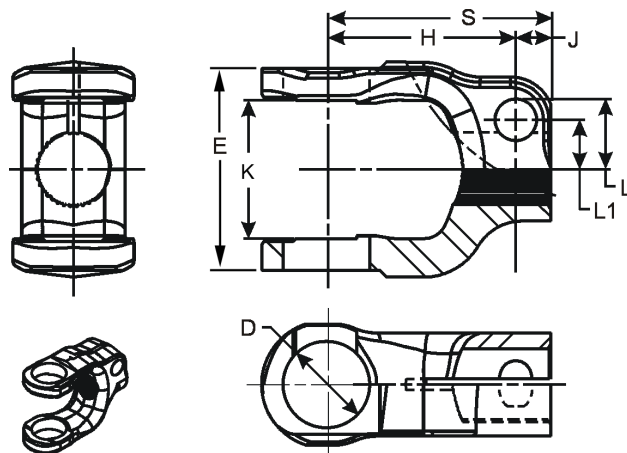

Serrated Hole		Bolt Hole Diameter	H	J	L	L1	S	End Yoke Part Number
Major Diameter	Minor Diameter (Nominal)		Center of Bolt Hole to Center of Bearing Hole	Center of Bolt Hole to End of Hub	Top of Bolt Hole to Center of Spline	Center of Bolt Hole to Center of Spline	Centerline to End of Hub	
1000 SERIES (Continued)			K-1.500	D-.938				USE KIT 5-103X
.994-30 Based On 36 Spline								
.994	.947	.405	1.750	.630	.802	—	2.380	10-4-391SX
.994	.947	.405	1.780	.470	.802	—	2.250	10-4-121SX
.994	.947	.405	1.780	.470	.802	—	2.250	10-4-561SX
.994	.947	.405	2.030	.470	.802	—	2.500	10-4-961SX
.994	.947	.405	2.030	.470	.802	—	2.500	10-4-371SX
.994	.947	.451	2.030	.470	.863	—	2.500	10-4-971SX
.994	.947	.451	2.030	.470	.863	—	2.500	10-4-451SX
.994	.947	.451	4.000	.470	.863	—	4.470	10-4-1201SX
.994	.947	.467	2.030	.470	.835	—	2.500	10-4-731SX
1.006-34 Based On 48 Spline								
1.006	.960	.468	2.030	.470	—	.630	2.500	10-4-661SX
1310 SERIES			E-3.469	D-1.062				USE KIT 5-251X
1.000-30 Based On 36 Spline								
1.000	.947	4.500	2.120	.760	—	.610	2.880	2-4-4411SX
1.000-36 Spline								
1.000	.947	.406	2.125	.437	—	.610	2.562	2-4-4461SX

• Part is discontinued ■ Part is available until supply is exhausted ▲ Not sold separately



Important: See Safety Information in General Information Section (J300P-GI)

STEERING SHAFT STRAIGHT ROUND HOLE With Snap Ring Design

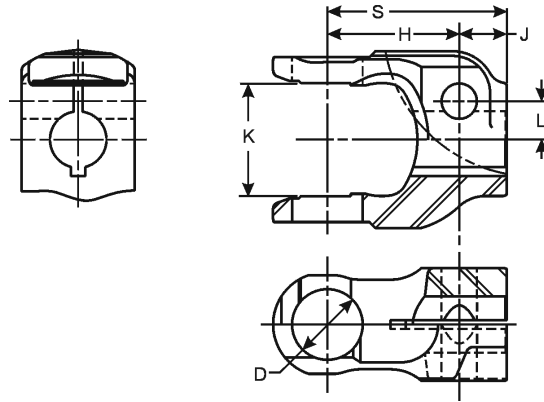

STRAIGHT ROUND HOLE			H	J	L	S	End Yoke Part Number
Hole Size Max./Min.	Keyway Width	Bolt Hole Diameter	Center of Bolt Hole to Center of Bearing Hole	Center of Bolt Hole to End of Hub	Center of Bolt Hole to Center of Hub Hole	Centerline to End of Hub	
1000 SERIES	K-1.500	D-.938	USE KIT 5-103X				
.7510/.7500	.1880	.4690	1.7500	.6250	.5100	2.3750	10-4-1673SX
.9860/.9850	.1880	.4670	1.7500	.6250	.5600	2.3750	10-4-1083SX
1.0005/.9995	.1880	.4060	1.6250	.7500	.5570	2.3750	10-4-1183SX

• Part is discontinued ■ Part is available until supply is exhausted ▲ Not sold separately



SLINGER STYLES

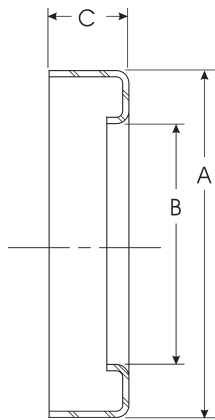

Style 1

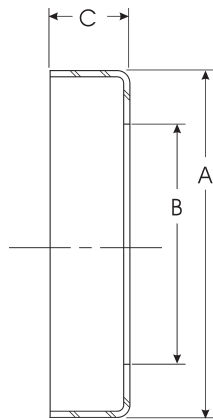

Style 2

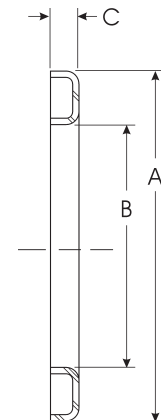

Style 3

Slinger Number	Style	A	B	C	Slinger Number	Style	A	B	C
232184 ▲	1	2.049	1.505	0.382	230998•	2	4.250	3.500	0.625
231302•	1	3.078	1.859	0.422	230859 ▲	2	4.750	2.938	0.312
232064 ▲	1	3.399	2.277	0.803	231047	2	4.891	3.500	0.750
231780 ▲	1	3.438	1.609	0.344	230902	2	5.720	4.067	0.920
231004	1	3.656	2.141	0.438	232746 ▲	2	5.940	3.697	0.710
233034 ▲	1	3.823	2.468	1.087	232002 ▲	2	6.000	3.141	0.375
230421	1	3.938	2.188	0.531	232027 ▲	2	6.000	3.141	0.359
230118	1	4.000	2.062	0.562	231866•	2	6.000	3.500	0.812
31875•	1	4.125	1.562	0.406	231745•	2	7.000	3.750	0.719
230124	1	4.134	2.308	0.560	15099•	3	2.125	1.562	0.219
231305 ▲	1	4.500	3.110	0.750	41498	3	2.125	1.603	0.219
232646 ▲	1	4.500	3.110	0.750	34592	3	2.438	1.875	0.219
230909	1	4.635	2.938	0.312	231877•	3	2.531	1.500	0.547
231541	1	4.688	2.954	0.500	330851•	3	2.844	1.562	0.406
231206	1	4.812	2.500	1.000	5003953 ▲	3	3.150	2.048	0.197
98-1361	1	4.812	2.953	0.812	5003955 ▲	3	3.150	2.168	0.197
231022	1	4.891	3.000	0.688	231620 ▲	3	3.812	3.031	0.266
231959 ▲	1	4.891	3.000	0.562	232367	3	4.000	3.000	0.812
231102	1	4.891	3.141	0.938	232039•	3	4.062	2.766	1.125
231357 ▲	1	5.000	3.109	0.750	231028	3	4.328	3.000	0.938
232189 ▲	1	5.000	3.109	0.750	565-W•	3	4.438	2.500	0.531
232638 ▲	1	5.150	3.095	1.937	232042-1 ▲	3	4.500	2.375	0.797
5003552	1	5.280	3.489	0.750	230746	3	4.625	2.391	0.875
232055	1	5.359	3.250	1.375	230910•	3	4.625	2.938	0.312
230795•	1	5.453	3.938	0.656	232372 ▲	3	4.688	3.109	1.675
231263 ▲	1	5.656	3.391	0.609	232042-2	3	4.906	2.625	0.500
231347•	1	5.672	3.031	0.469	232042-3 ▲	3	5.109	3.000	0.297
98-1362	1	5.719	2.839	0.875	232042-6 ▲	3	5.297	3.125	0.500
231179	1	5.750	3.391	0.938	232042-11•	3	5.406	3.375	0.406
231101 ■	1	6.000	2.938	0.938	230991 ▲	3	5.438	3.938	0.656
231359	1	6.000	3.125	0.812	230888•	3	5.650	4.250	0.656
232747 ▲	1	6.050	3.488	0.690	232042-10	3	5.797	3.375	0.406
230674	1	6.125	3.516	0.750	232193 ▲	3	6.438	4.016	0.500
232759 ▲	1	6.330	4.262	1.340					
231599	1	6.750	3.391	1.500					
230921	1	7.000	3.141	0.812					
231803	1	7.000	3.484	0.891					
231615	1	7.406	3.109	0.750					

• Part is discontinued

■ Part is available until supply is exhausted

▲ Not sold separately



Important: See Safety Information in General Information Section (J300P-GI)

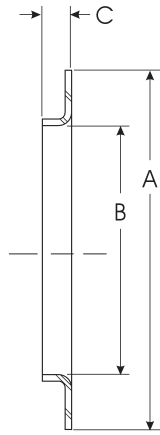

Style 4

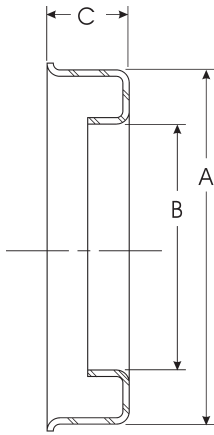

Style 5

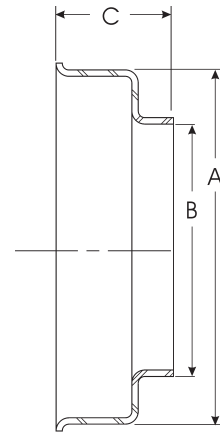

Style 6

Slinger Number	Style	A	B	C	Slinger Number	Style	A	B	C
42779•	4	3.125	2.188	0.340	231549•	6	2.266	1.781	0.500
232895▲	4	3.360	2.559	0.330	98-1473	6	2.266	1.781	0.500
230794	4	4.750	2.938	0.312	230881■	6	2.750	1.781	0.500
232182•	4	6.000	3.141	0.375	231636▲	6	3.000	2.281	0.578
231579▲	5	2.500	2.281	0.547	230865▲	6	3.281	2.188	0.562
231596▲	5	2.938	1.578	0.438	230629▲	6	3.375	2.031	0.719
232166	5	3.425	3.156	0.781	1015W▲	6	3.438	2.766	0.750
232168	5	3.766	3.000	0.641	230386•	6	3.562	2.375	1.250
232609•	5	3.820	3.000	1.260	230587▲	6	3.562	2.500	0.812
231750	5	3.954	3.031	0.375	231356	6	3.734	2.281	0.797
231755	5	3.954	3.062	0.562	5003086▲	6	3.965	3.094	0.709
232032▲	5	4.016	2.438	0.438	230897•	6	4.000	2.688	0.594
232514	5	4.125	2.750	0.390	232037▲	6	4.234	2.750	0.781
232610•	5	4.170	3.432	1.260	829W•	6	4.375	3.062	0.625
231616	5	4.594	3.844	0.422	330287•	6	4.562	2.766	0.891
232511	5	5.000	3.125	0.350	231366▲	6	4.672	2.844	0.891
					330287•	6	4.710	2.759	0.880
					231550▲	6	4.766	2.750	1.406
					231015	6	4.797	2.969	0.562
					330499•	6	5.000	3.062	0.812
					233038▲	6	7.368	4.795	0.658

• Part is discontinued

■ Part is available until supply is exhausted

▲ Not sold separately



SLINGER STYLES

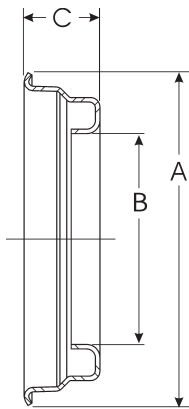

Style 9

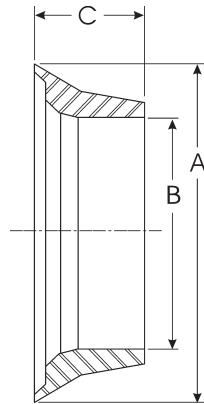

Style 10

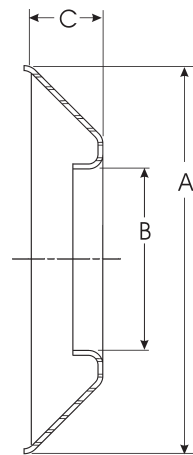

Style 7

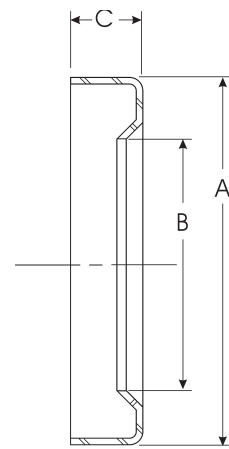

Style 8

Slinger Number	Style	A	B	C
231935 ▲	7	2.875	1.188	0.375
41195 •	7	2.891	1.891	0.422
232198 ▲	7	3.312	2.469	0.562
231872	7	3.469	2.562	0.625
232199	7	3.656	3.094	0.625
232200	7	3.828	3.094	0.562
230207 ■	7	4.375	2.531	0.875
230895	7	4.625	2.391	0.875
232201	7	4.812	3.594	1.000
232948 ▲	7	5.110	3.093	0.760
230900 •	7	5.500	2.766	0.844
231058 ▲	7	6.125	4.016	0.859

Slinger Number	Style	A	B	C
232816 ▲	8	3.696	2.185	0.590
231013	8	5.125	3.438	1.125
232760 ▲	8	6.320	4.262	2.126
232167 •	9	4.344	2.750	1.000
232604	9	4.781	3.000	1.070
42735	10	2.180	1.535	0.729

• Part is discontinued

■ Part is available until supply is exhausted

▲ Not sold separately



Important: See Safety Information in General Information Section (J300P-GI)

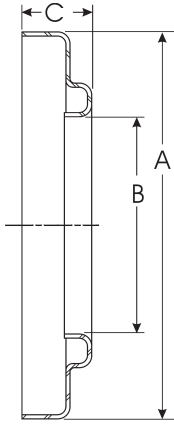

Style 11

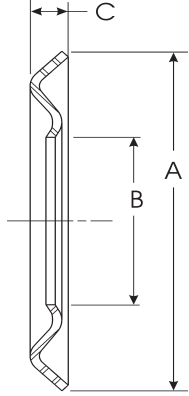

Style 12

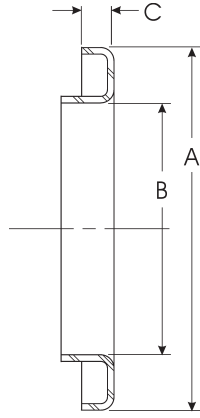

Style 13

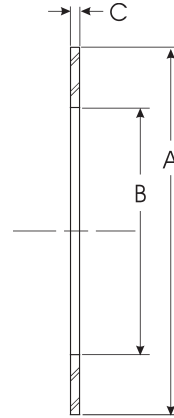

Style 14

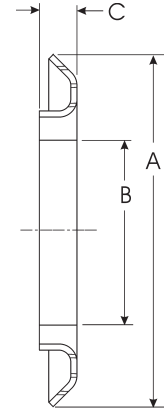

Style 15

Slinger Number	Style	A	B	C
231970 ▲	11	2.840	1.504	0.430
5003951 ▲	11	3.654	1.735	0.622
42501	11	5.120	1.875	0.793
233051•	11	5.886	3.135	0.984
5006975 ▲	11	5.886	3.135	0.984
5008437•	11	7.598	3.850	0.740

Slinger Number	Style	A	B	C
232020 ▲	12	2.176	1.504	0.280
30798	12	3.812	1.875	0.312
5001045 ▲	12	4.980	3.879	0.455
232028 ▲	13	5.760	3.515	0.060
5001780 ▲	14	6.850	4.007	0.430
5001687 ▲	14	8.150	4.262	0.430
5002871 ▲	15	4.710	3.133	0.984

• Part is discontinued

■ Part is available until supply is exhausted

▲ Not sold separately



1-4-222•.....	59	2-4-1981-1■.....	14	2-4-5331X.....	13
1-4-783.....	55	2-4-1991-1X.....	14	2-4-5341.....	15
1-4-803.....	55	2-4-2013.....	56	2-4-5411.....	14
1-4-823.....	55	2-4-2043.....	56	2-4-5421X.....	14
1-4-933.....	55	2-4-2271-1.....	13	2-4-5441.....	15
1-4-943.....	55	2-4-2371.....	14	2-4-5521-1.....	15
1-4-1133.....	55	2-4-2401-1.....	14	2-4-5681-1•.....	15
1-4-1201.....	12	2-4-2401•.....	14	2-4-5691-1X•.....	15
1-4-1383•.....	55	2-4-2411-1X.....	14	2-4-5781.....	14
1-4-3043•.....	55	2-4-2411X•.....	14	2-4-5851-1.....	13
1-4-3093•.....	55	2-4-2601-1•.....	14	2-4-5891•.....	12
1-4-3113•.....	55	2-4-2601•.....	14	2-4-5901-1.....	12
1-4-3133•.....	55	2-4-2611-1X.....	14	2-4-5911-1•.....	12
2-4-64.....	58	2-4-2611X.....	14	2-4-5921-1X.....	12
2-4-152•.....	59	2-4-2613.....	56	2-4-5991-1.....	15
2-4-154•.....	58	2-4-2671.....	14	2-4-6001-1.....	14
2-4-177.....	56	2-4-2791-1■.....	12	2-4-6011.....	14
2-4-353.....	56	2-4-2791-1■.....	12	2-4-6101•.....	15
2-4-411.....	14	2-4-2791•.....	12	2-4-6111X.....	15
2-4-433.....	56	2-4-2801-1X.....	12	2-4-6121-1•.....	12
2-4-443.....	56	2-4-2821-1X.....	12	2-4-6131-1X.....	12
2-4-453.....	56	2-4-2821X•.....	12	2-4-6161-1.....	13
2-4-463.....	56	2-4-2841-1•.....	12	2-4-6171-1■.....	13
2-4-473.....	56	2-4-2851-1X•.....	12	2-4-6181-1X•.....	13
2-4-502■.....	59	2-4-2901.....	14	2-4-6191-1.....	12
2-4-503.....	56	2-4-3161.....	13	2-4-6221.....	15
2-4-523.....	56	2-4-3331.....	12	2-4-6231•.....	15
2-4-533.....	56	2-4-3571-1■.....	15	2-4-6301.....	13
2-4-553.....	56	2-4-3581-1X.....	15	2-4-6341.....	14
2-4-573.....	56	2-4-3741-1.....	13	2-4-6401-1•.....	13
2-4-583.....	56	2-4-3771•.....	14	2-4-6411-1X•.....	13
2-4-613.....	56	2-4-3781X.....	14	2-4-6561-1.....	13
2-4-663.....	56	2-4-3791-1•.....	14	2-4-6641-1.....	13
2-4-783-1.....	56	2-4-3791•.....	14	2-4-6661-1■.....	12
2-4-783•.....	56	2-4-3801-1X.....	14	2-4-6671-1•.....	14
2-4-803.....	56	2-4-3801X.....	14	2-4-6721-1•.....	12
2-4-824.....	58	2-4-4011•.....	14	2-4-6731-1X.....	12
2-4-834.....	58	2-4-4021X.....	14	2-4-6781-1.....	13
2-4-853.....	56	2-4-4031-1.....	15	2-4-6851-1■.....	15
2-4-854•.....	58	2-4-4051•.....	12	2-4-6891-1■.....	13
2-4-1053.....	56	2-4-4061X.....	12	2-4-6901-1X.....	13
2-4-1103.....	56	2-4-4191-1.....	15	2-4-6981-1X•.....	12
2-4-1233.....	56	2-4-4291-1X.....	15	2-4-7021-1.....	13
2-4-1301.....	13	2-4-4341.....	13	2-4-7031-1X.....	15
2-4-1311.....	14	2-4-4471X.....	14	2-4-7111-1•.....	12
2-4-1363•.....	55	2-4-4601-1.....	13	2-4-7141-1.....	14
2-4-1413•.....	55	2-4-4801•.....	14	2-4-7151.....	14
2-4-1423•.....	55	2-4-4921.....	12	2-4-7181-1.....	15
2-4-1463•.....	55	2-4-4931.....	12	2-4-7221-1X.....	12
2-4-1721.....	12	2-4-5091.....	15	2-4-7291-1X.....	13
2-4-1731.....	14	2-4-5241■.....	13	2-4-7371-1X■.....	13
2-4-1741.....	14	2-4-5251X•.....	13	2-4-7401-1■.....	13
2-4-1831.....	14	2-4-5301•.....	15	2-4-7491-1•.....	13
2-4-1873•.....	55	2-4-5311X.....	15	2-4-7501-1X.....	13
2-4-1921.....	13	2-4-5321•.....	13	2-4-7631-1.....	15

• Part is discontinued

■ Part is available until supply is exhausted

▲ Not sold separately

2-4-7641-1	53	3-4-283-1	57	3-4-3491-1	19
2-4-7651-1X	53	3-4-333-1	57	3-4-3541-1	21
2-4-7661-1	53	3-4-343-1	57	3-4-3571-1	21
2-4-7671-1	53	3-4-543-1	56	3-4-3671-1X	17
2-4-7681-1X	53	3-4-613-1	57	3-4-3771	21
2-4-7731	14	3-4-813	56	3-4-3781-1	21
2-4-7801-1	15	3-4-1111-1	17	3-4-3801-1	17
2-4-7871-1	13	3-4-1161-1	19	3-4-3861-1	22
2-4-7871	13	3-4-1173	57	3-4-3901-1	22
2-4-7901-1	53	3-4-1211-1	17	3-4-3931-1	17
2-4-8031-1	12	3-4-1261-1	17	3-4-3931	17
2-4-8041-1	15	3-4-1371-1	17	3-4-3951-1	17
2-4-8041	15	3-4-1371	17	3-4-3961-1	19
2-4-8051-1X	15	3-4-1441-1	17	3-4-4051	21
2-4-8051X	15	3-4-1471-1	18	3-4-4211	22
2-4-8081-1	13	3-4-1481-1	18	3-4-4421-1X	20
2-4-8081	13	3-4-1501-1	17	3-4-4441-1	18
2-4-8091-1X	13	3-4-1743	57	3-4-4451-1X	18
2-4-8091X	13	3-4-1753	57	3-4-5101	15
2-4-8161	13	3-4-1763-1	57	3-4-5191-1	19
2-4-8171X	13	3-4-1763	57	3-4-5301	17
2-4-8181-1	13	3-4-1841-1	19	3-4-5321	18
2-4-8191-1X	13	3-4-1901-1	18	3-4-5341	15
2-4-8241	12	3-4-1911-1	19	3-4-5391X	17
2-4-8311-1	13	3-4-2051-1	16	3-4-5441-1	22
2-4-8321-1	13	3-4-2111-1	16	3-4-5701-1	18
2-4-8331-1	14	3-4-2131-1	19	3-4-5711-1X	18
2-4-8391-1X	14	3-4-2171-1	17	3-4-5721-1	16
2-4-8421-1	15	3-4-2231-1	17	3-4-5731-1X	16
2-4-8521-1	13	3-4-2241-1	19	3-4-5751-1	16
2-4-8531-1	13	3-4-2251-1	20	3-4-5761-1X	16
2-4-8541-1X	13	3-4-2271-1	18	3-4-5781-1X	21
2-4-8551-1X	13	3-4-2281	19	3-4-5791-1X	21
2-4-8691-1	13	3-4-2351-1	17	3-4-5811-1X	21
2-4-8701-1X	13	3-4-2511-1	19	3-4-5821-1X	22
2-4-4411SX	61	3-4-2781	16	3-4-5881-1X	19
2-4-4461SX	61	3-4-2841-1	18	3-4-5911	21
3-4-13	57	3-4-2851-1X	18	3-4-5921-1X	19
3-4-14-1	58	3-4-2941-1	19	3-4-6211-1	17
3-4-24-1	58	3-4-3041-1	19	3-4-6221-1X	21
3-4-33	56	3-4-3051-1	22	3-4-6231-1	21
3-4-43	57	3-4-3061-1	21	3-4-6241-1X	21
3-4-53	57	3-4-3081-1	20	3-4-6251	21
3-4-54-1	58	3-4-3081	20	3-4-6261X	21
3-4-64-1	58	3-4-3091-1	20	3-4-6411-1	21
3-4-84-1	58	3-4-3111-1	20	3-4-6531	19
3-4-93	57	3-4-3121-1	21	3-4-6561-1	18
3-4-103	57	3-4-3141-1	21	3-4-6631-1X	18
3-4-154-1	58	3-4-3191-1	21	3-4-6671-1X	22
3-4-163-1	57	3-4-3241-1	21	3-4-6701-1	20
3-4-178-1X	17	3-4-3291-1	17	3-4-6701	20
3-4-234-1	58	3-4-3331-1X	20	3-4-6751	19
3-4-243-1	57	3-4-3331X	20	3-4-6901-1	20
3-4-263-1	57	3-4-3351	19	3-4-6901-2	20
3-4-273-1	57	3-4-3391-1	21	3-4-7031-1	19

• Part is discontinued

■ Part is available until supply is exhausted

▲ Not sold separately

3-4-7131.....	19	3-4-10231-1■.....	19	3-4-12461-1.....	17
3-4-7141.....	18	3-4-10251-1.....	20	3-4-12531-1■.....	18
3-4-7151.....	19	3-4-10261-1.....	22	3-4-12541-1X•.....	18
3-4-7161•.....	21	3-4-10261-1.....	22	3-4-12611•.....	17
3-4-7171.....	21	3-4-10261•.....	22	3-4-12771-1•.....	16
3-4-7241-1.....	17	3-4-10281-1•.....	17	3-4-12771-2■.....	16
3-4-7241•.....	17	3-4-10301-1.....	21	3-4-12781-1X■.....	16
3-4-7251-1■.....	22	3-4-10461-1X.....	20	3-4-13001-1•.....	17
3-4-7261-1X.....	22	3-4-10471-1X.....	22	3-4-13011-1X.....	17
3-4-7311-1.....	19	3-4-10471X•.....	22	3-4-13021•.....	20
3-4-7321-1X.....	19	3-4-10541-1•.....	20	3-4-13031-1X•.....	16
3-4-7361-1.....	21	3-4-10551-1.....	19	3-4-13031-2X.....	16
3-4-7391-1X•.....	20	3-4-10571-1•.....	18	3-4-13051-1■.....	23
3-4-7401.....	17	3-4-10591-1.....	17	3-4-13061-1X.....	23
3-4-7541-1■.....	22	3-4-10931-1.....	18	3-4-13071-1.....	23
3-4-7541-2■.....	22	3-4-10941-1.....	18	3-4-13081-1X.....	23
3-4-7551.....	20	3-4-10951-1.....	18	3-4-13161.....	16
3-4-7571-1.....	22	3-4-11051-1.....	23	3-4-13211-1.....	17
3-4-7721-1.....	18	3-4-11061-1X.....	23	3-4-13341-1•.....	23
3-4-7781•.....	20	3-4-11071-1.....	22	3-4-13351-1X.....	23
3-4-7991-1•.....	19	3-4-11081-1X.....	19	3-4-13391-1X.....	20
3-4-8001-1X.....	19	3-4-11121-1•.....	22	3-4-13511-1.....	18
3-4-8031-1.....	19	3-4-11161-1•.....	21	3-4-13601-1.....	16
3-4-8051-1X.....	22	3-4-11171-1■.....	21	3-4-13731-1.....	17
3-4-8061X.....	20	3-4-11171-1■.....	21	3-4-13761-1.....	16
3-4-8071-1•.....	20	3-4-11181-1•.....	21	3-4-13791-1•.....	21
3-4-8071•.....	20	3-4-11221-1■.....	16	3-4-13821-1.....	21
3-4-8491-1•.....	17	3-4-11231-1X•.....	16	3-4-13871-1■.....	19
3-4-8501-1.....	17	3-4-11281-1X.....	21	3-4-13881-1.....	17
3-4-8511-1.....	17	3-4-11421-1•.....	16	3-4-13901-1.....	21
3-4-8681-1.....	17	3-4-11441-1•.....	16	3-4-13911-1.....	19
3-4-8691-1X.....	17	3-4-11471-1.....	18	3-4-13921-1•.....	20
3-4-8701-1•.....	19	3-4-11551-1•.....	22	3-4-13931-1.....	22
3-4-8721-1.....	20	3-4-11561-1.....	21	3-4-14031-1.....	21
3-4-8731-1.....	18	3-4-11591-1.....	19	3-4-14371-1.....	19
3-4-8781-1.....	22	3-4-11621-1X.....	22	3-4-14371-1.....	19
3-4-9001-1X•.....	17	3-4-11701-1X.....	19	3-4-14391-1X.....	19
3-4-9001X•.....	17	3-4-11711-1.....	17	3-4-14451-1.....	17
3-4-9031•.....	21	3-4-11721-1.....	16	3-4-14461-1.....	17
3-4-9231-1•.....	22	3-4-11741-1•.....	19	3-4-14531-1.....	16
3-4-9231-2•.....	22	3-4-11761-1.....	19	3-4-14541-1X■.....	16
3-4-9241-1X•.....	22	3-4-11771-1•.....	22	3-4-14551-1.....	21
3-4-9241-2X•.....	22	3-4-11811-1.....	19	3-4-14591-1.....	18
3-4-9251-2.....	19	3-4-11851-1.....	18	3-4-14621-1.....	16
3-4-9271-1.....	21	3-4-11871-2.....	21	3-4-14671-1■.....	16
3-4-9271-2.....	21	3-4-11891-1X.....	18	3-4-14681-1■.....	18
3-4-9301-1.....	21	3-4-11901-1•.....	16	3-4-14701-1X•.....	16
3-4-9531-1•.....	20	3-4-11911-1X.....	16	3-4-14711-1X.....	18
3-4-9551-1.....	18	3-4-11921-1X•.....	22	3-4-14721-1X•.....	19
3-4-9561-1X.....	18	3-4-11931-1X.....	16	3-4-14731-1X•.....	21
3-4-9621.....	21	3-4-12091-1•.....	22	3-4-14781-1■.....	23
3-4-9821-1.....	16	3-4-12101-1X.....	22	3-4-14781-1■.....	23
3-4-9931-1•.....	19	3-4-12111-1•.....	22	3-4-14781-1■.....	23
3-4-9941-1.....	16	3-4-12121-1X•.....	22	3-4-14781-1■.....	23
3-4-9981-1•.....	22	3-4-12211-1■.....	16	3-4-14791-1X.....	23

• Part is discontinued

■ Part is available until supply is exhausted

▲ Not sold separately

3-4-14841-1X■	23	4-4-5161-1■	25	5-4-1324	58
4-4-843-1	57	4-4-5171-1X•	25	5-4-1391	28
4-4-1901-1	23	4-4-5231-1■	24	5-4-1431•	27
4-4-1921-1	23	4-4-5241-1X■	24	5-4-1521	28
4-4-1931-1	23	4-4-5251-1•	23	5-4-1631•	28
4-4-1941-1•	24	4-4-5261-1	25	5-4-1641-1■	27
4-4-1941•	24	4-4-5551-1•	24	5-4-1641•	27
4-4-2041-1	23	4-4-5571-1•	23	5-4-1661-1	28
4-4-2051-1	23	4-4-5581-1•	25	5-4-1661	28
4-4-2091-1	23	4-4-5601-1	23	5-4-1721-1	26
4-4-2381-1	24	4-4-5611-1X	24	5-4-1721	26
4-4-2401-1	25	4-4-5621-1•	25	5-4-1831	28
4-4-2431-1•	24	4-4-5691-1X	25	5-4-1891-1•	30
4-4-2431-2•	24	4-4-5701-1X•	25	5-4-1891	30
4-4-2451-1	25	4-4-5721-1•	23	5-4-1931•	26
4-4-2481-1	25	4-4-5841-1■	25	5-4-2031X	27
4-4-2511-1	23	4-4-5941-1X	25	5-4-2081-1•	26
4-4-2531-1•	25	4-4-5991-1	23	5-4-2081	26
4-4-2931-1	24	4-4-6101-1	24	5-4-2141•	31
4-4-2941•	25	4-4-6141-1•	23	5-4-2331	31
4-4-3501-1	25	4-4-6211-1•	25	5-4-2341•	31
4-4-3581-1X	23	4-4-6331-1	23	5-4-2401	26
4-4-3811-1	23	4-4-6471-1■	25	5-4-2501•	27
4-4-3841-1•	23	4-4-6641-1•	25	5-4-2521•	26
4-4-3851-1•	24	4-4-6711-1	23	5-4-2531	27
4-4-3861-1X	24	4-4-6731-1X•	25	5-4-2541•	27
4-4-3931-2	25	4-4-6781-2■	24	5-4-3141•	30
4-4-4071-1X	24	4-4-6791-2	23	5-4-3241	27
4-4-4071-2X•	24	4-4-6841-1•	23	5-4-3601X	26
4-4-4101-1	24	4-4-6851-1X	23	5-4-3621	26
4-4-4111-1X	24	4-4-6951-1•	24	5-4-3681•	27
4-4-4171-1•	23	4-4-6961-1X	24	5-4-3861■	26
4-4-4191-1	24	4-4-6971-1•	24	5-4-3901•	26
4-4-4211-1	23	4-4-6981-1X	24	5-4-3911•	27
4-4-4211-2	23	4-4-6991-1•	25	5-4-4161X•	31
4-4-4361-1	25	4-4-7001-1X	25	5-4-4221•	27
4-4-4371-1•	25	4-4-7011-1•	25	5-4-4381•	28
4-4-4381-1■	25	4-4-7111-1X	25	5-4-4391	27
4-4-4421-1	25	4-4-7211-1M	25	5-4-4401	29
4-4-4451-1X	25	4-4-7241-1•	25	5-4-4441X•	26
4-4-4491-1	24	4-4-7251-1X	25	5-4-4461-1•	26
4-4-4611-1•	24	4-4-7341-1	24	5-4-4461	26
4-4-4611-2	24	4-4-7421-1■	23	5-4-4471-1•	27
4-4-4611	24	4-4-7431-1■	24	5-4-4541	27
4-4-4771-2	24	4-4-7551-1X	25	5-4-4551	27
4-4-4781-1	23	4-4-7561-1■	25	5-4-4571	26
4-4-4781-2	23	4-4-7571-1X	25	5-4-4701■	31
4-4-4791-1•	24	4-4-7861-1X	23	5-4-4721•	27
4-4-4791-2•	24	4-4-7871-1X	24	5-4-4741■	30
4-4-4801-1X	24	5-4-413	57	5-4-4751X	30
4-4-4801-2X	24	5-4-453•	57	5-4-4761X	26
4-4-4811-1	24	5-4-781	26	5-4-4771X	27
4-4-5061-1	24	5-4-871•	26	5-4-4831-1•	27
4-4-5091-1	25	5-4-1051	26	5-4-4831•	27
4-4-5111-1•	23	5-4-1221■	28	5-4-4841-1X	27

• Part is discontinued

■ Part is available until supply is exhausted

▲ Not sold separately

5-4-4841X.....	27	5-4-6241	29	5-4-7311-1X.....	29
5-4-4861-1	31	5-4-6251■.....	26	5-4-7331-1•.....	31
5-4-4861	31	5-4-6261-1.....	26	5-4-7341-1X.....	31
5-4-4901X•.....	26	5-4-6261■.....	26	5-4-7351-1■.....	31
5-4-4961-1■.....	30	5-4-6271■.....	28	5-4-7361-1X•.....	31
5-4-4961	30	5-4-6281X.....	28	5-4-7381-1•.....	30
5-4-4971	31	5-4-6291-1X.....	29	5-4-7391-1X.....	30
5-4-5031-1•.....	29	5-4-6291X.....	29	5-4-7431-1■.....	30
5-4-5031•.....	29	5-4-6321-1.....	28	5-4-7441-1X.....	30
5-4-5081X.....	26	5-4-6321	28	5-4-7481-1•.....	28
5-4-5091	27	5-4-6341	27	5-4-7551-1•.....	29
5-4-5111-1X.....	26	5-4-6351	27	5-4-7561-1•.....	29
5-4-5111X.....	26	5-4-6361-1X.....	27	5-4-7561-1•.....	29
5-4-5121-1X•.....	27	5-4-6371-1•.....	30	5-4-7561•.....	29
5-4-5121X.....	27	5-4-6371•.....	30	5-4-7561•.....	29
5-4-5131X.....	28	5-4-6381-1X.....	30	5-4-7571-1X•.....	29
5-4-5161-1X.....	29	5-4-6381X•.....	30	5-4-7571X.....	29
5-4-5161X.....	29	5-4-6421-1•.....	28	5-4-7581-1•.....	26
5-4-5221•.....	27	5-4-6421-1•.....	28	5-4-7601-1.....	28
5-4-5231X•.....	27	5-4-6421•.....	28	5-4-7631-1•.....	26
5-4-5281X.....	27	5-4-6431-1X.....	28	5-4-7641-1•.....	30
5-4-5321X.....	27	5-4-6431X.....	28	5-4-7651-1X•.....	30
5-4-5361-1•.....	31	5-4-6441-1X.....	28	5-4-7691-1X•.....	28
5-4-5421•.....	28	5-4-6481-1.....	28	5-4-7701-1■.....	27
5-4-5441•.....	28	5-4-6481•.....	28	5-4-7781-1•.....	27
5-4-5461	28	5-4-6521-1.....	30	5-4-7941-1•.....	27
5-4-5461	28	5-4-6531-1•.....	31	5-4-7951-1•.....	31
5-4-5491-1X•.....	31	5-4-6541-1•.....	28	5-4-7971-1•.....	29
5-4-5501•.....	29	5-4-6581-1■.....	29	5-4-7971•.....	29
5-4-5501•.....	29	5-4-6591-1X.....	29	5-4-7981-1■.....	29
5-4-5511X.....	29	5-4-6871X•.....	28	5-4-7991•.....	29
5-4-5571-1.....	26	5-4-6891X.....	30	5-4-8001•.....	27
5-4-5621-1X.....	26	5-4-6941-1.....	26	5-4-8021-1•.....	30
5-4-5631■.....	30	5-4-6951X.....	28	5-4-8021-1•.....	30
5-4-5711.....	26	5-4-6961X.....	28	5-4-8031-1X.....	30
5-4-5721	27	5-4-6981-1•.....	26	5-4-8041	26
5-4-5731	29	5-4-7031-1•.....	26	5-4-8061-1X.....	27
5-4-5741•.....	30	5-4-7041-1.....	27	5-4-8131-1X.....	29
5-4-5751	29	5-4-7061-1.....	28	5-4-8211-1X.....	30
5-4-5821•.....	31	5-4-7101-1X•.....	28	5-4-8261-1•.....	29
5-4-5831-1•.....	31	5-4-7111-1•.....	27	5-4-8261	29
5-4-5851-1.....	31	5-4-7121X.....	28	5-4-8301•.....	29
5-4-5861X.....	28	5-4-7171-1.....	27	5-4-8311-1•.....	30
5-4-5881	28	5-4-7181X.....	29	5-4-8321-1■.....	30
5-4-5961	29	5-4-7191■.....	30	5-4-8341-1•.....	31
5-4-5971X.....	29	5-4-7201X.....	30	5-4-8351-1X.....	31
5-4-5981■.....	29	5-4-7211X•.....	30	5-4-8361-1.....	27
5-4-5991X.....	29	5-4-7221X.....	29	5-4-8411-1X.....	29
5-4-6101-1X•.....	31	5-4-7231X.....	30	5-4-8411X.....	29
5-4-6131■.....	28	5-4-7251X.....	27	5-4-8421X.....	29
5-4-6131■.....	28	5-4-7261-1■.....	27	5-4-8431-1X.....	30
5-4-6141-1•.....	31	5-4-7261•.....	27	5-4-8441X.....	27
5-4-6151-1X•.....	31	5-4-7271-1•.....	29	5-4-8461-1•.....	30
5-4-6161-1•.....	31	5-4-7271-1•.....	29	5-4-8491-1•.....	27
5-4-6241-1•.....	29	5-4-7301-1X.....	27	5-4-8501-1X.....	27

• Part is discontinued

■ Part is available until supply is exhausted

▲ Not sold separately

5-4-8561-1■	27	6-4-2081-1■	31	6-4-4271	32
5-4-8571-1X	27	6-4-2081•	31	6-4-4291X	33
5-4-8581-1•	28	6-4-2141	37	6-4-4301X	32
5-4-8591-1X	28	6-4-2181-1•	36	6-4-4361X	32
5-4-8601-1	29	6-4-2181■	36	6-4-4371	32
5-4-8611-1X	29	6-4-2191-1•	33	6-4-4391X	33
5-4-8621-1•	30	6-4-2191	33	6-4-4411-1X•	36
5-4-8631-1X	30	6-4-2211	33	6-4-4411X	36
5-4-8641-1•	30	6-4-2251-1■	39	6-4-4421-1■	39
5-4-8651-1X	30	6-4-2251	39	6-4-4421-1■	39
5-4-8661-1•	27	6-4-2331•	36	6-4-4421	39
5-4-8671-1X	27	6-4-2361-1■	33	6-4-4481X	32
5-4-8681-1	29	6-4-2361	33	6-4-4531	37
5-4-8691-1X	29	6-4-2371	33	6-4-4551-1	40
5-4-8711X	29	6-4-2381	32	6-4-4551	40
5-4-8851-1	27	6-4-2391	32	6-4-4561-1	37
5-4-8901-1X	27	6-4-2431	35	6-4-4561	37
5-4-8911-1	27	6-4-2441	36	6-4-4581-1•	39
5-4-8961-1	28	6-4-2501•	36	6-4-4581	39
5-4-8971-1	28	6-4-2511	36	6-4-4591-1•	36
5-4-9101-1X	30	6-4-2601X•	36	6-4-4591	36
5-4-9111-1X	29	6-4-3001	34	6-4-4591	36
5-4-9121-1X•	29	6-4-3021	40	6-4-4601	37
5-4-9121X•	29	6-4-3031-1•	36	6-4-4651-1	40
5-4-9131-1X•	29	6-4-3031	36	6-4-4651	40
5-4-9141-1	30	6-4-3031	36	6-4-4681X	36
5-4-9141	30	6-4-3041-1X	36	6-4-4721-1•	33
5-4-9191-1M	31	6-4-3041X	36	6-4-4721•	33
5-4-9221-1■	29	6-4-3081•	38	6-4-4731-1X	33
5-4-9231-1X	29	6-4-3131	33	6-4-4731X■	33
5-4-9241-1X	29	6-4-3141	41	6-4-4741X	33
5-4-9241X■	29	6-4-3161	39	6-4-4751-1X	39
5-4-9261-1X•	30	6-4-3221•	32	6-4-4751X	39
5-4-9271X•	29	6-4-3241	33	6-4-4771-1	39
5-4-9291-1•	29	6-4-3241	33	6-4-4771	39
5-4-9311-1X	29	6-4-3271■	33	6-4-4781	39
5-4-9351-1	29	6-4-3291	33	6-4-4851-1X•	33
5-4-9421-1■	29	6-4-3391•	32	6-4-4851X	33
5-4-9431-1•	29	6-4-3461X	36	6-4-4861X	32
5-4-9441-1X	29	6-4-3491	36	6-4-4871	33
5-4-9451-1X	29	6-4-3501-1■	37	6-4-4901■	34
5-4-9511-1	27	6-4-3671	40	6-4-4921	40
5-4-9541-1X	31	6-4-3791	35	6-4-4961•	36
5-4-9571-1	31	6-4-3831-1	33	6-4-4971	34
5-4-9581-1■	31	6-4-3831	33	6-4-5031-1■	32
5-4-9621-1■	31	6-4-3871	36	6-4-5031•	32
5-4-9631-1X	31	6-4-3901	33	6-4-5041-1X	32
5-4-9741•	26	6-4-4121•	36	6-4-5041X	32
6-4-1971	36	6-4-4131■	32	6-4-5061X	36
6-4-1981-1	33	6-4-4141■	32	6-4-5071X	37
6-4-1981	32	6-4-4151-1•	33	6-4-5101X	34
6-4-1991-1•	36	6-4-4151•	33	6-4-5111X	32
6-4-1991	36	6-4-4171-1X	36	6-4-5131-1X	32
6-4-2001	33	6-4-4171X	36	6-4-5131X	32
6-4-2061	33	6-4-4261	33	6-4-5141•	33

• Part is discontinued

■ Part is available until supply is exhausted

▲ Not sold separately

6-4-5151X.....	33	6-4-6371-1.....	34	6-4-7071X.....	40
6-4-5201.....	40	6-4-6371.....	34	6-4-7081-1•.....	38
6-4-5251X.....	40	6-4-6371.....	34	6-4-7141-1.....	33
6-4-5271•.....	37	6-4-6371.....	34	6-4-7141.....	33
6-4-5291.....	33	6-4-6381X.....	34	6-4-7161-1.....	39
6-4-5341.....	37	6-4-6391-1X.....	34	6-4-7161-1.....	39
6-4-5351-1■.....	40	6-4-6391X.....	34	6-4-7161■.....	38
6-4-5351■.....	40	6-4-6401-1■.....	34	6-4-7171X.....	35
6-4-5451-1•.....	38	6-4-6401.....	34	6-4-7181-1X.....	39
6-4-5451■.....	38	6-4-6401.....	34	6-4-7181X.....	38
6-4-5461-1X.....	38	6-4-6411X.....	34	6-4-7191X.....	37
6-4-5461X.....	38	6-4-6421-1X.....	34	6-4-7201•.....	37
6-4-5471.....	35	6-4-6421X.....	34	6-4-7211X.....	37
6-4-5481X.....	36	6-4-6451-1.....	32	6-4-7221X.....	35
6-4-5501-1•.....	34	6-4-6451.....	32	6-4-7231X.....	33
6-4-5501.....	34	6-4-6481.....	32	6-4-7241X.....	37
6-4-5521-1.....	34	6-4-6571-1•.....	34	6-4-7251-1•.....	37
6-4-5521.....	34	6-4-6571■.....	34	6-4-7251■.....	37
6-4-5541•.....	34	6-4-6601-1.....	38	6-4-7271-1X.....	37
6-4-5581-1X•.....	31	6-4-6601-1.....	38	6-4-7271X•.....	37
6-4-5581X■.....	31	6-4-6601.....	38	6-4-7291X.....	33
6-4-5711■.....	37	6-4-6611-1.....	39	6-4-7301-1.....	33
6-4-5741•.....	38	6-4-6611.....	39	6-4-7301.....	33
6-4-5781•.....	33	6-4-6631-1■.....	40	6-4-7311-1.....	35
6-4-5791.....	35	6-4-6631•.....	40	6-4-7311-1.....	35
6-4-5801.....	37	6-4-6671•.....	37	6-4-7311•.....	35
6-4-5811■.....	35	6-4-6761-1X.....	39	6-4-7321-1X.....	35
6-4-5831.....	37	6-4-6761X.....	39	6-4-7371-1■.....	37
6-4-5841-1•.....	38	6-4-6771X.....	37	6-4-7381-1X.....	37
6-4-5841■.....	38	6-4-6821-1.....	40	6-4-7481-1.....	39
6-4-5851-1.....	34	6-4-6821■.....	40	6-4-7491-1•.....	39
6-4-5851.....	34	6-4-6841-1X.....	40	6-4-7511-1•.....	39
6-4-5931-1■.....	38	6-4-6841X.....	40	6-4-7511-1•.....	39
6-4-5931-1■.....	38	6-4-6861-1•.....	37	6-4-7511.....	39
6-4-5931•.....	38	6-4-6871-1X.....	34	6-4-7531-1X.....	39
6-4-5931•.....	38	6-4-6871X.....	34	6-4-7531X.....	39
6-4-5961-1X■.....	38	6-4-6891X.....	36	6-4-7541-1.....	36
6-4-5961X.....	38	6-4-6901-1X.....	37	6-4-7541-1.....	36
6-4-5991.....	34	6-4-6921-1X.....	39	6-4-7541.....	35
6-4-6001X.....	34	6-4-6921X.....	39	6-4-7541.....	35
6-4-6011-1■.....	35	6-4-6931-1X.....	40	6-4-7551-1■.....	35
6-4-6011.....	35	6-4-6931X.....	40	6-4-7551-1■.....	35
6-4-6021-1X.....	35	6-4-6941X.....	34	6-4-7551.....	35
6-4-6021X.....	35	6-4-6951-1X.....	34	6-4-7551.....	35
6-4-6041-1X.....	37	6-4-6951X.....	34	6-4-7561-1X.....	35
6-4-6041X.....	37	6-4-6961-1X.....	38	6-4-7561X.....	35
6-4-6201•.....	33	6-4-6961X.....	38	6-4-7571-1.....	32
6-4-6211-1■.....	38	6-4-6971-1•.....	37	6-4-7581-1X.....	32
6-4-6231-1.....	38	6-4-6971.....	37	6-4-7621-1.....	34
6-4-6241-1X•.....	38	6-4-6991-1•.....	38	6-4-7621-1.....	34
6-4-6321-1.....	32	6-4-7041-1X.....	39	6-4-7621-1.....	34
6-4-6321.....	32	6-4-7041X.....	39	6-4-7631-1X.....	34
6-4-6331-1■.....	32	6-4-7051-1■.....	39	6-4-7641-1X.....	34
6-4-6331.....	32	6-4-7051.....	39	6-4-7651-1X.....	36
6-4-6371-1.....	34	6-4-7071-1X.....	40	6-4-7651X.....	35

• Part is discontinued

■ Part is available until supply is exhausted

▲ Not sold separately

6-4-7661-1•.....	40	6-4-8461.....	37	6-4-9171X.....	35
6-4-7691-1.....	40	6-4-8461.....	37	6-4-9181-1X.....	35
6-4-7691•.....	40	6-4-8471•.....	39	6-4-9181X.....	35
6-4-7731-1X.....	38	6-4-8511-1X.....	32	6-4-9191-1X.....	36
6-4-7741-1X•.....	33	6-4-8511X.....	32	6-4-9191X.....	35
6-4-7751-1•.....	31	6-4-8521-1X.....	32	6-4-9201-1X.....	39
6-4-7761-1■.....	39	6-4-8521X.....	32	6-4-9221-1.....	36
6-4-7761•.....	39	6-4-8531-1X.....	35	6-4-9221.....	36
6-4-7771-1X.....	39	6-4-8531X.....	34	6-4-9231-1.....	40
6-4-7771X.....	39	6-4-8541-1X.....	35	6-4-9231.....	40
6-4-7831-1■.....	38	6-4-8541X.....	35	6-4-9281-1.....	35
6-4-7831■.....	38	6-4-8551-1X.....	37	6-4-9291-1■.....	35
6-4-7851-1X.....	38	6-4-8551X.....	37	6-4-9301-1X.....	35
6-4-7851X.....	38	6-4-8561-1.....	36	6-4-9311-1M•.....	38
6-4-7881-1X.....	38	6-4-8571-1X.....	34	6-4-9321-1XM•.....	38
6-4-7881X.....	38	6-4-8571X.....	34	6-4-9411-1.....	34
6-4-7891-1X.....	38	6-4-8601-1X■.....	34	6-4-9421-1•.....	35
6-4-7961-1.....	37	6-4-8651-1■.....	33	6-4-9421-1•.....	35
6-4-7961-1.....	37	6-4-8661-1X.....	33	6-4-9431-1X.....	35
6-4-7961•.....	37	6-4-8671-1.....	35	6-4-9441-1X•.....	35
6-4-7961•.....	37	6-4-8681-1X.....	35	6-4-9521-1.....	37
6-4-7971-1X.....	37	6-4-8691-1.....	37	6-4-9531-1X.....	38
6-4-7971X.....	37	6-4-8701-1X.....	37	6-4-9561-1M■.....	40
6-4-7981-1•.....	35	6-4-8711-1■.....	37	6-4-9571-1XM•.....	40
6-4-7981.....	35	6-4-8721-1X.....	37	6-4-9691■.....	41
6-4-7991-1•.....	34	6-4-8731-1.....	33	6-4-9701X.....	41
6-4-7991-1•.....	35	6-4-8741-1X.....	33	6-4-9741-1M■.....	40
6-4-7991.....	34	6-4-8751-1•.....	35	6-4-9751-1XM•.....	40
6-4-8001-1■.....	32	6-4-8761-1X.....	35	6-4-9781-1■.....	38
6-4-8001.....	32	6-4-8771-1■.....	37	6-4-9791-1X.....	38
6-4-8081-1■.....	32	6-4-8781-1X.....	37	6-4-9841-1X•.....	36
6-4-8081.....	32	6-4-8791-1•.....	37	6-4-9841X.....	36
6-4-8231-1X.....	34	6-4-8801-1X.....	37	6-4-9911-1■.....	38
6-4-8291-1X.....	37	6-4-8821-1•.....	40	6-4-9951-1■.....	33
6-4-8321-1X.....	39	6-4-8831-1•.....	38	6-4-9961-1X.....	33
6-4-8321X•.....	39	6-4-8841-1•.....	39	6-4-9971-1M.....	38
6-4-8331-1X.....	34	6-4-8851-1.....	40	6-4-10011-1.....	38
6-4-8331X.....	34	6-4-8851.....	40	6-4-10291-1■.....	39
6-4-8341-1X.....	38	6-4-8981-1X.....	37	6-4-10291■.....	39
6-4-8341X.....	38	6-4-8981X•.....	37	6-4-10301-1■.....	45
6-4-8351-1X.....	39	6-4-8991-1X.....	35	6-4-10301■.....	35
6-4-8361-1X.....	34	6-4-8991X.....	35	6-4-10311-1■.....	39
6-4-8361X.....	34	6-4-9001-1X.....	35	6-4-10311■.....	39
6-4-8411-1.....	35	6-4-9001X.....	35	6.3-4-41-1■.....	43
6-4-8411.....	35	6-4-9021-1.....	32	6.3-4-41•.....	43
6-4-8421-1.....	35	6-4-9031-1X.....	35	6.3-4-51-1■.....	41
6-4-8421.....	35	6-4-9031X.....	35	6.3-4-51■.....	41
6-4-8431-1.....	35	6-4-9041-1X.....	35	6.3-4-61-1.....	44
6-4-8431.....	35	6-4-9041X.....	35	6.3-4-61.....	43
6-4-8441-1.....	35	6-4-9131-1.....	39	6.3-4-71•.....	41
6-4-8441.....	35	6-4-9141■.....	39	6.3-4-81•.....	41
6-4-8451-1.....	37	6-4-9151X•.....	39	6.3-4-91-1■.....	41
6-4-8451.....	37	6-4-9161-1X.....	37	6.3-4-91■.....	41
6-4-8461-1.....	37	6-4-9161X•.....	37	6.3-4-101-1•.....	42
6-4-8461-1.....	37	6-4-9171-1X.....	35	6.3-4-101•.....	42

• Part is discontinued

■ Part is available until supply is exhausted

▲ Not sold separately

6.3-4-111..... 41	6.3-4-721-1X..... 43	6.3-4-1331-1X..... 41
6.3-4-121•..... 41	6.3-4-721X..... 43	6.3-4-1331X..... 41
6.3-4-131-1■..... 43	6.3-4-731-1X..... 41	6.3-4-1341-1X•..... 41
6.3-4-131•..... 43	6.3-4-731X..... 41	6.3-4-1391-1X..... 42
6.3-4-141-1■..... 41	6.3-4-751-1•..... 42	6.3-4-1391X..... 42
6.3-4-141•..... 41	6.3-4-771-1X..... 43	6.3-4-1401-1X..... 43
6.3-4-151-1•..... 43	6.3-4-771X..... 43	6.3-4-1401X..... 43
6.3-4-151■..... 43	6.3-4-781-1X..... 43	6.3-4-1411-1•..... 42
6.3-4-161-1..... 42	6.3-4-781X..... 43	6.3-4-1411..... 42
6.3-4-161..... 42	6.3-4-791-1X..... 43	6.3-4-1421-1..... 42
6.3-4-171-1X..... 41	6.3-4-791X..... 43	6.3-4-1421..... 42
6.3-4-171X..... 41	6.3-4-811-1■..... 43	6.3-4-1421..... 42
6.3-4-181X..... 41	6.3-4-811•..... 43	6.3-4-1421..... 42
6.3-4-191X•..... 41	6.3-4-821-1..... 43	6.3-4-1481-1X..... 42
6.3-4-211-1X..... 42	6.3-4-831■..... 42	6.3-4-1481X..... 42
6.3-4-211X..... 42	6.3-4-841-1•..... 42	6.3-4-1491-1■..... 41
6.3-4-221X..... 41	6.3-4-851X..... 42	6.3-4-1501-1X•..... 41
6.3-4-231X..... 41	6.3-4-861-1X..... 42	6.3-4-1511-1..... 41
6.3-4-241-1X•..... 43	6.3-4-861X..... 42	6.3-4-1521-1X..... 41
6.3-4-241X..... 43	6.3-4-871-1X..... 43	6.3-4-1531-1■..... 42
6.3-4-251-1X•..... 41	6.3-4-871X..... 43	6.3-4-1541-1X..... 42
6.3-4-251X■..... 41	6.3-4-901-1X•..... 42	6.3-4-1551-1■..... 42
6.3-4-271-1..... 42	6.3-4-1021X..... 42	6.3-4-1561-1X..... 42
6.3-4-271..... 42	6.3-4-1031-1..... 43	6.3-4-1591-1..... 41
6.3-4-291-1•..... 42	6.3-4-1031-1..... 43	6.3-4-1601-1•..... 42
6.3-4-291-1•..... 42	6.3-4-1031•..... 43	6.3-4-1611-1X..... 42
6.3-4-291•..... 42	6.3-4-1041-1X..... 43	6.3-4-1621-1X..... 42
6.3-4-291•..... 42	6.3-4-1041X..... 43	6.3-4-1621X•..... 41
6.3-4-301-1X..... 42	6.3-4-1051-1•..... 44	6.3-4-1631-1X•..... 41
6.3-4-301X..... 42	6.3-4-1061-1■..... 41	6.3-4-1641X•..... 41
6.3-4-331-1X..... 42	6.3-4-1061-1■..... 41	6.3-4-1651-1X..... 43
6.3-4-331X..... 42	6.3-4-1061•..... 41	6.3-4-1651X•..... 43
6.3-4-381-1..... 43	6.3-4-1071-1X•..... 41	6.3-4-1681-1..... 44
6.3-4-381..... 43	6.3-4-1071X..... 41	6.3-4-1681..... 44
6.3-4-391-1•..... 42	6.3-4-1091-1•..... 41	6.3-4-1701-1•..... 41
6.3-4-391..... 42	6.3-4-1101-1X•..... 41	6.3-4-1711-1X..... 41
6.3-4-421•..... 41	6.3-4-1141-1X•..... 41	6.3-4-1861-1■..... 43
6.3-4-431..... 41	6.3-4-1151-1•..... 43	6.3-4-1861■..... 43
6.3-4-441•..... 42	6.3-4-1151-1•..... 43	6.3-4-5221-1X..... 42
6.3-4-521..... 43	6.3-4-1151•..... 43	6.3-4-5221X..... 42
6.3-4-531-1..... 41	6.3-4-1151•..... 43	6.5-4-1891-1..... 45
6.3-4-531-1..... 41	6.3-4-1161-1X..... 43	6.5-4-1891..... 45
6.3-4-531-1..... 41	6.3-4-1161X..... 43	6.5-4-1901..... 47
6.3-4-531..... 41	6.3-4-1171•..... 41	6.5-4-1911■..... 45
6.3-4-541-1X..... 41	6.3-4-1191-1..... 44	6.5-4-1921•..... 44
6.3-4-541X..... 41	6.3-4-1251-1..... 43	6.5-4-1941•..... 47
6.3-4-641-1..... 43	6.3-4-1251•..... 43	6.5-4-1971-1..... 45
6.3-4-641-1..... 42	6.3-4-1261X..... 41	6.5-4-1971..... 45
6.3-4-641..... 42	6.3-4-1271-1X..... 43	6.5-4-1971..... 45
6.3-4-651-1..... 43	6.3-4-1281-1X..... 42	6.5-4-1991-1•..... 46
6.3-4-651..... 43	6.3-4-1281X..... 42	6.5-4-1991..... 46
6.3-4-661-1■..... 43	6.3-4-1321-1•..... 41	6.5-4-2001..... 44
6.3-4-661■..... 43	6.3-4-1321-1•..... 42	6.5-4-2011..... 47
6.3-4-711-1..... 43	6.3-4-1321■..... 41	6.5-4-2021..... 45
6.3-4-711..... 43	6.3-4-1321■..... 41	6.5-4-2051..... 44

• Part is discontinued

■ Part is available until supply is exhausted

▲ Not sold separately

6.5-4-2101-1.....	47	6.5-4-3201•.....	46	6.5-4-3721-1.....	46
6.5-4-2101-1.....	47	6.5-4-3221-1X.....	46	6.5-4-3721-1.....	46
6.5-4-2101■.....	47	6.5-4-3221X.....	46	6.5-4-3721-1.....	46
6.5-4-2131.....	45	6.5-4-3251-1.....	46	6.5-4-3721■.....	46
6.5-4-2141-1■.....	45	6.5-4-3251.....	46	6.5-4-3731-1X.....	46
6.5-4-2151■.....	47	6.5-4-3261-1.....	44	6.5-4-3731X.....	46
6.5-4-2171-1.....	47	6.5-4-3261.....	44	6.5-4-3801-1.....	47
6.5-4-2171.....	47	6.5-4-3281-1X.....	45	6.5-4-3821-1.....	47
6.5-4-2181.....	47	6.5-4-3281X.....	45	6.5-4-3841-1■.....	45
6.5-4-2261■.....	45	6.5-4-3361-1.....	47	6.5-4-3851-1X.....	45
6.5-4-2271X.....	45	6.5-4-3361.....	47	6.5-4-3861-1■.....	44
6.5-4-2291-1■.....	45	6.5-4-3371-1.....	44	6.5-4-3881-1X.....	44
6.5-4-2291•.....	45	6.5-4-3371-1.....	44	6.5-4-3911-1.....	46
6.5-4-2341X.....	44	6.5-4-3371.....	44	6.5-4-3911-1.....	46
6.5-4-2351X.....	44	6.5-4-3381-1X.....	44	6.5-4-3911.....	46
6.5-4-2361-1X.....	46	6.5-4-3381X.....	44	6.5-4-3911.....	46
6.5-4-2361X.....	46	6.5-4-3441-1■.....	46	6.5-4-3921-1X.....	46
6.5-4-2401-1X•.....	45	6.5-4-3441-1■.....	46	6.5-4-3921X.....	46
6.5-4-2401X.....	45	6.5-4-3441.....	46	6.5-4-3931.....	45
6.5-4-2441■.....	45	6.5-4-3441.....	46	6.5-4-3931.....	45
6.5-4-2451X.....	45	6.5-4-3451-1.....	47	6.5-4-3941-1.....	48
6.5-4-2471•.....	45	6.5-4-3451•.....	47	6.5-4-4001-1X.....	46
6.5-4-2491X.....	45	6.5-4-3461-1•.....	47	6.5-4-4001X•.....	46
6.5-4-2531X.....	45	6.5-4-3461•.....	47	6.5-4-4011-1X.....	46
6.5-4-2541-1.....	46	6.5-4-3491-1.....	47	6.5-4-4011X.....	46
6.5-4-2541.....	46	6.5-4-3491■.....	47	6.5-4-4081-1.....	45
6.5-4-2551X.....	45	6.5-4-3501-1X.....	47	6.5-4-4081-1.....	45
6.5-4-2561-1.....	47	6.5-4-3501X.....	47	6.5-4-4091-1X.....	45
6.5-4-2561.....	47	6.5-4-3541-1X.....	47	6.5-4-4191-1X•.....	44
6.5-4-2581-1.....	45	6.5-4-3541X.....	47	6.5-4-4211-1.....	45
6.5-4-2581.....	45	6.5-4-3551-1X.....	47	6.5-4-4221-1X•.....	45
6.5-4-2601X•.....	47	6.5-4-3551X.....	47	6.5-4-4231-1•.....	45
6.5-4-2621-1■.....	48	6.5-4-3561-1X.....	47	6.5-4-4241-1X.....	45
6.5-4-2621.....	48	6.5-4-3561X.....	47	6.5-4-4251X.....	45
6.5-4-2681.....	48	6.5-4-3571-1X•.....	44	6.5-4-4261-1X.....	47
6.5-4-2701-1•.....	46	6.5-4-3571X.....	44	6.5-4-4271-1X.....	46
6.5-4-2701.....	46	6.5-4-3581-1X.....	46	6.5-4-4271X.....	46
6.5-4-2711-1X.....	46	6.5-4-3581X.....	46	6.5-4-4281-1X.....	44
6.5-4-2711X.....	46	6.5-4-3591-1.....	46	6.5-4-4281X.....	44
6.5-4-2781-1■.....	44	6.5-4-3611-1•.....	47	6.5-4-4291-1X.....	47
6.5-4-2781•.....	44	6.5-4-3611■.....	47	6.5-4-4291X.....	47
6.5-4-2821.....	44	6.5-4-3621-1X.....	47	6.5-4-4311-1.....	45
6.5-4-2831X.....	45	6.5-4-3621X•.....	47	6.5-4-4311.....	45
6.5-4-2911.....	44	6.5-4-3631■.....	46	6.5-4-4321-1.....	45
6.5-4-2921.....	47	6.5-4-3641X.....	46	6.5-4-4321-1.....	45
6.5-4-2931X.....	47	6.5-4-3651X.....	46	6.5-4-4321.....	45
6.5-4-2961.....	44	6.5-4-3681-1■.....	45	6.5-4-4321.....	45
6.5-4-3011.....	45	6.5-4-3681-1■.....	45	6.5-4-4351-1X.....	45
6.5-4-3021-1■.....	47	6.5-4-3681•.....	45	6.5-4-4351X.....	45
6.5-4-3021.....	47	6.5-4-3681•.....	45	6.5-4-4401-1X.....	48
6.5-4-3081.....	48	6.5-4-3691-1X•.....	45	6.5-4-4401X.....	48
6.5-4-3161■.....	46	6.5-4-3691X.....	45	6.5-4-4411-1•.....	46
6.5-4-3201-1■.....	46	6.5-4-3711-1X.....	47	6.5-4-4421-1X.....	46
6.5-4-3201-1■.....	46	6.5-4-3711X.....	47	6.5-4-4431-1■.....	46
6.5-4-3201•.....	46	6.5-4-3721-1.....	46	6.5-4-4441-1X.....	46

• Part is discontinued

■ Part is available until supply is exhausted

▲ Not sold separately

6.5-4-4451-1■	45	10-4-83	54	10-4-971SX	61
6.5-4-4461-1X	45	10-4-93	54	10-4-991SX•	60
6.5-4-4471-1•	46	10-4-101	11	10-4-1001SX	60
6.5-4-4481-1X	46	10-4-103	55	10-4-1061SX	60
6.5-4-4511-1X	46	10-4-113	55	10-4-1083SX	62
6.5-4-4521-1•	48	10-4-121SX	61	10-4-1181SX•	60
6.5-4-4541■	47	10-4-123	55	10-4-1183SX	62
6.5-4-4551X	47	10-4-133	54	10-4-1201SX	61
6.5-4-4571-1X	45	10-4-143	55	10-4-1241SX•	60
6.5-4-4571X	45	10-4-153	55	10-4-1281SX•	60
6.5-4-4591-1X	45	10-4-163	55	10-4-1473	55
6.5-4-4601-1X•	45	10-4-183	55	10-4-1673SX	62
6.5-4-4601X■	45	10-4-193	55	55-4-11-1	2
6.5-4-4611-1X	46	10-4-203	54	55-4-31-1■	2
6.5-4-4611X	46	10-4-213	55	55-4-41-1X	2
6.5-4-4621X•	45	10-4-223	55	55-4-71-1■	2
6.5-4-4631-1	48	10-4-233■	55	55-4-81-1X•	2
6.5-4-4631	48	10-4-282	59	55-4-91-1■	2
6.5-4-4651-1•	45	10-4-293	55	55-4-101-1X•	2
6.5-4-4661-1X	45	10-4-303	54	55-4-121-1■	2
6.5-4-4721-1X	46	10-4-333	54	55-4-131-1X•	2
6.5-4-5091-1•	47	10-4-371SX	61	55-4-201-1■	2
6.5-4-5091■	47	10-4-373	54	70-4-11-1	2
6.5-4-5101-1•	47	10-4-383	55	70-4-51-1■	2
6.5-4-5101■	47	10-4-391SX	61	70-4-61-1X	2
8-4-791•	48	10-4-431SX	60	70-4-101-1■	2
8-4-851	52	10-4-443	54	70-4-111-1X	2
8-4-1061	52	10-4-451SX	61	70-4-141-1■	2
8-4-1141•	52	10-4-453	54	70-4-151-1X	2
8-4-1141•	52	10-4-461SX	60	70-4-161-1■	2
8-4-1151X	52	10-4-481	11	70-4-171-1X•	2
8-4-1161X	52	10-4-491SX	60	70-4-181-1■	2
8-4-1321■	48	10-4-501SX	60	70-4-191-1X•	2
8-4-1341■	48	10-4-551SX	60	70-4-261-1■	2
8-4-1351X	48	10-4-561SX	61	70-4-271-1X•	2
8-4-1381X•	48	10-4-573	54	90-4-11-1	3
9-4-301■	48	10-4-601SX	60	90-4-21-1	3
9-4-311X•	48	10-4-611SX	60	90-4-71-1	3
10-4-11	11	10-4-621SX	60	90-4-111-1	3
10-4-12	59	10-4-631SX	60	90-4-161-1•	3
10-4-13	54	10-4-641	11	90-4-171-1X•	3
10-4-21	11	10-4-661SX	61	90-4-181-1•	3
10-4-22	59	10-4-693	54	90-4-191-1X	3
10-4-23	54	10-4-713	54	90-4-201-1■	3
10-4-31	11	10-4-731SX	61	90-4-211-1X•	3
10-4-32	59	10-4-741SX	60	90-4-241-1	3
10-4-33•	54	10-4-821SX	60	90-4-251-1X	3
10-4-42	59	10-4-841SX	60	90-4-281-1•	3
10-4-43	54	10-4-851SX	60	90-4-311-1	3
10-4-52	59	10-4-871SX	60	90-4-321-1X	3
10-4-53	54	10-4-901SX	60	90-4-331-1•	4
10-4-62	59	10-4-911SX	60	90-4-341-1X	4
10-4-63	54	10-4-931SX	60	90-4-351-1•	4
10-4-73	54	10-4-951SX	60	90-4-361-1X•	4
10-4-82	59	10-4-961SX	61	90-4-371-1	3

• Part is discontinued

■ Part is available until supply is exhausted

▲ Not sold separately

90-4-381-1.....	3	140-4-301-1■.....	5	170-4-221-1X.....	6
90-4-391-1.....	3	140-4-301-1■.....	5	170-4-231-1•.....	6
90-4-461-1■.....	3	140-4-311-1X.....	5	170-4-241-1X.....	6
90-4-471-1■.....	3	140-4-321-1■.....	5	170-4-251-1•.....	7
90-4-501-1X.....	3	140-4-331-1X.....	5	170-4-261-1X.....	7
90-4-521-1■.....	4	140-4-361-1•.....	5	170-4-271-1■.....	7
90-4-531-1X.....	4	140-4-371-1X.....	5	170-4-281-1X.....	7
90-4-541-1•.....	3	140-4-381-1■.....	5	170-4-291-1•.....	8
90-4-551-1X.....	3	140-4-391-1X.....	5	170-4-301-1X.....	8
90-4-561-1•.....	3	140-4-421-1■.....	5	170-4-311-1■.....	7
90-4-571-1X.....	3	140-4-431-1X.....	5	170-4-321-1X.....	7
90-4-581-1•.....	3	140-4-441-1■.....	5	170-4-331-1•.....	7
90-4-591-1X.....	3	140-4-451-1X.....	5	170-4-341-1X.....	7
90-4-601-1•.....	4	140-4-751-1.....	5	170-4-351-1■.....	7
90-4-611-1X.....	4	140-4-761-1•.....	5	170-4-361-1X.....	7
90-4-621-1■.....	3	140-4-771-1.....	6	170-4-371-1■.....	7
90-4-631-1X.....	3	140-4-881-1.....	5	170-4-381-1X.....	7
90-4-691-1X.....	3	140-4-891-1.....	4	170-4-411-1■.....	8
90-4-751-1•.....	3	140-4-901-1■.....	5	170-4-421-1X.....	8
90-4-761-1X.....	3	140-4-911-1X•.....	5	170-4-451-1.....	7
90-4-791-1.....	3	140-4-921-1■.....	5	170-4-461-1X•.....	7
100-4-891-1■.....	4	140-4-931-1X•.....	5	170-4-471-1■.....	8
100-4-901-1X.....	4	140-4-1011-1.....	5	170-4-481-1X.....	8
100-4-931-1.....	4	140-4-1021-1•.....	5	170-4-491-1•.....	8
100-4-951-1■.....	4	140-4-1091-1■.....	5	170-4-501-1X.....	8
100-4-961-1X•.....	4	140-4-1101-1X•.....	5	170-4-511-1.....	8
100-4-1011-1■.....	4	140-4-1111-1■.....	5	170-4-521-1X.....	8
100-4-1021-1X.....	4	140-4-1121-1X.....	5	170-4-531-1•.....	8
100-4-1071-1■.....	4	140-4-1131-1•.....	5	170-4-541-1.....	6
100-4-1081-1X.....	4	140-4-1151-1■.....	5	170-4-561-1.....	8
100-4-1321-1■.....	4	140-4-1161-1X•.....	5	170-4-571-1■.....	7
100-4-1331-1X.....	4	140-4-1191-1■.....	5	170-4-571-1■.....	7
100-4-1361-1■.....	4	140-4-1201-1X•.....	5	170-4-581-1X•.....	7
100-4-1371-1X.....	4	140-4-1231-1•.....	5	170-4-591-1X.....	7
100-4-1381-1X.....	3	140-4-1261-1■.....	5	170-4-601-1■.....	7
140-4-11-1.....	5	140-4-1271-1X•.....	5	170-4-611-1X.....	7
140-4-41-1•.....	5	140-4-1391-1■.....	5	170-4-631-1•.....	6
140-4-51-1X.....	5	140-4-1401-1X.....	5	170-4-641-1.....	6
140-4-61-1■.....	5	140-4-1421-1•.....	5	170-4-641-1.....	6
140-4-71-1X.....	5	140-4-1431-1X•.....	5	170-4-641-1.....	6
140-4-81-1■.....	6	170-4-21-1■.....	7	170-4-651-1X.....	6
140-4-91-1X.....	6	170-4-31-1X.....	7	170-4-661-1•.....	6
140-4-111-1.....	4	170-4-91-1■.....	7	170-4-661-1•.....	6
140-4-141-1■.....	5	170-4-101-1X•.....	7	170-4-671-1X.....	6
140-4-151-1X•.....	5	170-4-111-1•.....	6	170-4-681-1X•.....	6
140-4-181-1•.....	4	170-4-121-1X.....	6	170-4-691-1X.....	6
140-4-201-1.....	6	170-4-131-1■.....	6	170-4-701-1X•.....	6
140-4-211-1■.....	5	170-4-141-1X.....	6	170-4-711-1•.....	7
140-4-211-1■.....	5	170-4-151-1■.....	6	170-4-711-1•.....	8
140-4-231-1X.....	5	170-4-161-1X■.....	6	170-4-721-1X.....	7
140-4-241-1X.....	5	170-4-171-1■.....	6	170-4-731-1■.....	8
140-4-251-1■.....	4	170-4-181-1X■.....	6	170-4-741-1X.....	8
140-4-261-1X.....	4	170-4-191-1•.....	7	170-4-771-1.....	6
140-4-271-1■.....	5	170-4-201-1X.....	7	170-4-781-1■.....	7
140-4-291-1X.....	5	170-4-211-1•.....	6	170-4-791-1X•.....	7

• Part is discontinued

■ Part is available until supply is exhausted

▲ Not sold separately

170-4-801-1■	7	250-4-161-1X	9	131442K	39
170-4-811-1X	7	250-4-191-1■	9	131443K	47
170-4-821-1	7	250-4-201-1X	9	131444K	47
170-4-831-1	7	250-4-211-1■	9	131446K	9
170-4-841-1	6	250-4-221-1X	9	131447K	47
170-4-841-1	6	250-4-231-1•	9	131448K	47
170-4-851-1X	6	250-4-241-1X	9	131449K	35
170-4-861-1X	6	250-4-251-1•	9	131450K	45
170-4-891-1■	7	250-4-271-1	9	131451K	7
170-4-901-1X	7	250-4-281-1■	9	131482K	43
170-4-921-1	6	250-4-281-1■	9	131518K	43
170-4-951-1•	7	250-4-291-1X	9	131519K	39
170-4-961-1X	7	250-4-301-1X	9	131530K	39
170-4-1011-1■	7	250-4-341-1•	9	132863K	8
170-4-1021-1X•	7	250-4-341-1•	9	132931K	8
170-4-1031-1	7	250-4-351-1X	9	5001036■	3
170-4-1041-1X	7	250-4-361-1	9	5001046	3
170-4-1061-1•	7	250-4-371-1X■	9	5001480	2
170-4-1081-1	7	250-4-381-1•	8	5001694■	4
170-4-1091-1•	8	250-4-391-1X	8	5001766•	7
170-4-1141-1•	8	250-4-411-1■	8	5001768•	6
170-4-1161-1	8	250-4-421-1X	8	5001781•	2
170-4-1171-1■	7	250-4-471-1•	9	5001782■	2
170-4-1191-1X	7	250-4-501-1•	9	5001789	2
170-4-1211-1•	7	250-4-511-1•	9	5002012■	15
170-4-1221-1X	7	250-4-521-1X	9	5002013■	15
170-4-1251-1	6	250-4-531-1■	9	5002015■	15
170-4-1261-1X	6	250-4-541-1X	9	5002687■	48
170-4-1271-1	7	250-4-551-1	9	5002688•	48
170-4-1281-1•	7	250-4-561-1	9	5002872■	29
170-4-1291-1X	7	250-4-601-1■	9	5002873	29
170-4-1341-1•	8	250-4-621-1X	9	5002874■	4
170-4-1351-1X	8	250-4-641-1	9	5002875	4
170-4-1441-1	7	250-4-651-1X	9	5002876■	36
170-4-1621-1■	7	250-4-701-1■	9	5002877	36
170-4-1631-1X•	7	250-4-711-1X	9	5003087	4
170-4-1641-1■	6	250-4-751-1•	9	5003329■	2
170-4-1651-1X•	6	250-4-761-1X	9	5003330	2
170-4-1681-1	8	250-4-771-1■	9	5003553	39
170-4-1711-1	8	250-4-781-1X•	9	5003555	43
170-4-1891-1•	8	250-4-791-1■	9	5003556	46
170-4-1901-1■	7	250-4-801-1X	9	5003557	5
170-4-1911-1■	8	250-4-811-1	9	5003558	8
250-4-21-1	9	250-4-901-1•	9	5003560	9
250-4-31-1■	9	250-4-911-1	10	5003634	51
250-4-41-1X	9	250-4-1021-1■	9	5003950	15
250-4-51-1■	9	250-4-1031-1■	9	5003952	15
250-4-61-1X	9	131433K	8	5003954	15
250-4-71-1•	9	131434K	8	5004159	30
250-4-81-1X	9	131435K	9	5004358■	30
250-4-91-1■	9	131437K	39	5004772■	52
250-4-101-1X	9	131438K	39	5004773	52
250-4-131-1■	8	131439K	39	5004785	20
250-4-141-1X	8	131440K	43	5004898■	31
250-4-151-1■	9	131441K	43	5004899■	31

• Part is discontinued

■ Part is available until supply is exhausted

▲ Not sold separately

5005217▪.....	8	5C-4-111.....	49	9C-4-91.....	52
5005579▪.....	39	6C-4-31.....	49	9C-4-111.....	52
5005580•.....	39	6C-4-41.....	50	9C-4-211•.....	52
5005581▪.....	43	6C-4-61.....	49	10C-4-21▪.....	52
5005582▪.....	43	6C-4-71.....	49	10C-4-81.....	52
5005679▪.....	44	6C-4-81.....	49		
5005680.....	48	6C-4-91.....	49		
5005681▪.....	10	6C-4-101.....	49		
5006607▪.....	4	6C-4-111.....	49		
5006608.....	4	6C-4-141.....	49		
5006714▪.....	8	6C-4-191.....	49		
5006976.....	23	6C-4-201.....	49		
5006977.....	2	6C-4-251.....	49		
5007193▪.....	36	6C-4-261.....	50		
5007597▪.....	41	7C-4-11.....	51		
5007598▪.....	4	7C-4-31.....	50		
5007599▪.....	5	7C-4-41M.....	50		
5007600▪.....	5	7C-4-61.....	51		
5008270▪.....	30	7C-4-71.....	50		
5008438.....	39	7C-4-81.....	50		
5008439.....	39	7C-4-91.....	51		
5008440.....	43	7C-4-101.....	51		
5008441.....	43	7C-4-111M.....	51		
5008442.....	47	7C-4-121.....	50		
5008443.....	47	7C-4-131.....	50		
5008444.....	8	7C-4-141.....	50		
5008445.....	9	7C-4-151M.....	50		
5008446.....	35	7C-4-161.....	51		
5008447.....	45	7C-4-171.....	51		
5008448.....	7	7C-4-191.....	51		
5008449.....	39	7C-4-201.....	50		
5008450.....	39	7C-4-211.....	50		
5008451.....	8	7C-4-241.....	50		
5008452.....	39	7C-4-251.....	50		
5008453.....	39	7C-4-261.....	50		
5008454.....	43	7C-4-271.....	51		
5008455.....	43	7C-4-281M.....	50		
5008456.....	47	7C-4-291.....	50		
5008457.....	47	7C-4-311.....	50		
5008458.....	8	7C-4-321.....	51		
5008459.....	9	7C-4-351.....	51		
5008461.....	8	7C-4-401M.....	51		
5008577.....	7	7C-4-471M.....	51		
5008578.....	6	8.5C-4-11.....	52		
5009705.....	6	8.5C-4-21.....	51		
4C-4-11.....	49	8.5C-4-31.....	52		
4C-4-21.....	49	8.5C-4-41.....	51		
4C-4-31.....	49	8.5C-4-51.....	51		
4C-4-41.....	49	8.5C-4-61.....	51		
5C-4-41.....	49	8.5C-4-71.....	51		
5C-4-51.....	49	8.5C-4-111.....	52		
5C-4-61.....	49	8C-4-51.....	51		
5C-4-71M.....	49	8C-4-101.....	51		
5C-4-91.....	49	9C-4-41•.....	52		
5C-4-101.....	49	9C-4-81.....	52		

• Part is discontinued

■ Part is available until supply is exhausted

▲ Not sold separately



SPICER[®]

Drivetrain Products

Dana Holding Corporation
Spicer Service Parts
PO Box 321
Toledo, Ohio 43697-0321
1-800-SAY-DANA (729-3262)
www.spicerparts.com

Dana Holding Corporation
Spicer Service Parts - Canada
5095 South Service Road
Beamsville, Ontario LOR 1B0

Dana Holding Corporation
Spicer Service Parts - International
(419) 861-6325