



LUBER FINER
BUILT TO DO MORE™

On-Highway Engine Overview

Bob Ingham

Updated: May 20, 2015



ISB6.7

Filters

Luberfiner Part Number	FRAM Part Number	Part Type	OE Number	Quantity	Comment
LFF1065	PS10716	Fuel	4935879	1	Pri. Water Separator
LFF5632	P10715	Fuel	4934845	1	Sec.
LFP3970	PH8942	Lube	3937736	1	(1 1/8 in. Thd.) Spin-on



Engine Highlights

Displacement (L):	6.7
HP Range:	200 - 325
Torque Range (ft*lb):	520 - 750

OEM Highlights

- Medium duty engine that provides reliability & durability.
- VGT Turbocharger
 - High pressure common rail fuel system
 - Cummins after treatment emissions system

Chassis



Freightliner M2 106



International Durastar



Freightliner 108SD

Engine Volume

Model	Power (Hp)	Emission	CY 2013	CY 2014	CY 2015	CY 2016	CY 2017	CY 2018
6.7L 24v ohv L6	200 - 325	U.S. 04 / U.S. 10	75153	80618	83852	84224	84069	88430



CUMMINS POWERTRAIN



ISL9

Filters

Luberfiner Part Number	FRAM Part Number	Part Type	OE Number	Quantity	Comment
LFF1065	PS10716	Fuel	4934879	1	Pri. Water Separator
LFF5488	P10780	Fuel	4940647	1	Sec.
LFP3000XL	HPH9500	Lube	3401544	1	
LFW4071	PR3908	Coolant	3100304	1	



Engine Highlights

Displacement (L):	8.9
HP Range:	280 - 450
Torque Range (ft*lb):	720 - 1,250

OEM Highlights

- Reliable engine with a high power density in its class.
- VGT Turbocharger
- XPI fuel system
- Cummins after treatment emissions system

Engine Volume

Model	Power (Hp)	Emission	CY 2013	CY 2014	CY 2015	CY 2016	CY 2017	CY 2018
8.9L 24v ohv L6	280 - 450	U.S. 10, 04 / Euro V, IV	15915	16620	17324	17195	16890	18172

Chassis



Freightliner M2 106



Western Star 4700



Freightliner 108SD



Mack Granite



ISM

Filters

Luberfiner Part Number	FRAM Part Number	Part Type	OE Number	Quantity	Comment
LFF1003	PS8687	Fuel	3406889	1	
LFP9000	PH8690	Lube	3406810	1	Full Flow By-pass long
LFW4071	PR3908	Coolant	3100304	1	1 oz. Chemical

Chassis

N/A



Engine Highlights

Displacement (L):	10.8
HP Range:	280 - 500
Torque Range (ft*lb):	1,150 - 1,550

OEM Highlights

Built to deliver performance with minimum maintenance.

- VGT Turbocharger
- High pressure fuel injection system
- Cooled EGR system

Engine Volume

Model	Power (Hp)	Emission	CY 2013	CY 2014	CY 2015	CY 2016	CY 2017	CY 2018
10.8L 24v ohv L6	280 - 500	Euro V, IV, III / U.S. 10, 04	5440	5643	5830	5526	5462	6024



ISX12

Filters

Luberfiner Part Number	FRAM Part Number	Part Type	OE Number	Quantity	Comment
LFP9001	PH8691	Lube	LF9080	1	
LFW2126	PR8693	Coolant	4907485	1	3 oz. Chemical
LFF5686	P11022	Fuel	3685306	1	
L9763FXL	CS11023	Fuel	102526 or 102527	1	



Engine Highlights

Displacement (L):	11.9
HP Range:	310 - 425
Torque Range (ft*lb):	1,150 - 1,650

OEM Highlights

- Reliable engine with a high power-to-weight ratio.
- VGT Turbocharger
 - XPI fuel system
 - Cummins after treatment emissions system

Chassis



Peterbilt 579



Peterbilt 384



Kenworth T800

Engine Volume

Model	Power (Hp)	Emission	CY 2013	CY 2014	CY 2015	CY 2016	CY 2017	CY 2018
11.9L 24v dohc L6	310 - 425	U.S. 07 / U.S. 10	24123	25330	25735	22833	20724	24246



CUMMINS POWERTRAIN



ISX15

Filters

Luberfiner Part Number	FRAM Part Number	Part Type	OE Number	Quantity	Comment
LFP9001	PH8691	Lube	3406809	1	short
LFW2126	PR8693	Coolant	4907485	1	3 oz. Chemical
LFF5686	P11022	Fuel	3685306	1	



Engine Highlights	
Displacement (L):	15.0
HP Range:	385 - 600
Torque Range (ft*lb):	1,450 - 2,050
OEM Highlights	
Only engine offered by every major NA truck manufacturer.	
- VGT Turbocharger	
- XPI fuel system	
- Cummins after treatment emissions system	

Engine Volume

Model	Power (Hp)	Emission	CY 2013	CY 2014	CY 2015	CY 2016	CY 2017	CY 2018
15.0L 24v dohc L6	385 - 600	U.S. 10, 07 / Euro IV	79509	82415	84809	74732	68314	79724

Chassis



International 9900i



Freightliner Coronado



Peterbilt 579



Western Star 4900



DETROIT DIESEL POWERTRAIN

DD13

Filters

Luberfiner Part Number	FRAM Part Number	Part Type	OE Number	Quantity	Comment
L5091F	K10799	Fuel	A0000903451	1	Kit (- 2013) L5104F (2013-2015)
LP5090	CH10797	Lube	A4721800109	1	Cart.
LW4076XL	CR11262	Coolant	A4722020255	1	Extended Drain w/o Chemical
L9915F	CS11122	Fuel		1	Elemax Davco Fuel System

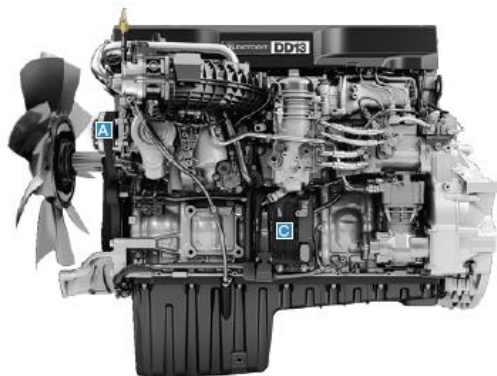

Engine Highlights

Displacement (L):	12.8
HP Range:	350 - 450
Torque Range (ft*lb):	1,250 - 1,650

OEM Highlights

- Technology that delivers smoothness & fuel efficiency.
- Amplified common rail system
 - BlueTec emissions technology
 - Variable speed water pump

Engine Volume

Model	Power (Hp)	Emission	CY 2013	CY 2014	CY 2015	CY 2016	CY 2017	CY 2018
12.8L 24v sohc L6	350 - 450	U.S. 10 / U. S. 07 / Euro V	32547	35228	37277	32997	30361	34727

Chassis



Freightliner M2 112



Western Star 4900



Western Star 4700



Freightliner Coronado



DETROIT DIESEL POWERTRAIN

DD15

Filters

Luberfiner Part Number	FRAM Part Number	Part Type	OE Number	Quantity	Comment
L5091F	K10799	Fuel	A0000903451	1	Kit (- 2013) L5104F (2013-2015)
LP5090	CH10797	Lube	A4721800109	1	Cart.
LW4076XL	CR11262	Coolant	A4722020255	1	Extended Drain w/o Chemical
L9915F	CS11122	Fuel		1	Elemex Davco Fuel System



Engine Highlights

Displacement (L):	14.8
HP Range:	455 - 560
Torque Range (ft*lb):	1,550 - 1,750

OEM Highlights

- Powerful engine with performance & fuel efficiency.
- Amplified common rail system
 - BlueTec emissions technology
 - Variable speed water pump

Engine Volume

Model	Power (Hp)	Emission	CY 2013	CY 2014	CY 2015	CY 2016	CY 2017	CY 2018
14.8L 24v sohc L6	455 - 560	U.S. 10 / U. S. 07	27077	28464	29747	26345	24635	29137

Chassis



Freightliner Cascadia



Western Star 6900



Western Star 4900



Freightliner Coronado



DETROIT DIESEL POWERTRAIN



DD16

Filters

Luberfiner Part Number	FRAM Part Number	Part Type	OE Number	Quantity	Comment
L5091F	K10799	Fuel	A0000903451	1	Kit (- 2013) L5104F (2013-2015)
LP5090	CH10797	Lube	A4721800109	1	Cart.
LW4076XL	CR11262	Coolant	A4722020255	1	Extended Drain w/o Chemical
L9915F	CS11122	Fuel		1	Elemex Davco Fuel System

Chassis



Freightliner Cascadia



Western Star 6900



Western Star 4900



Freightliner Coronado

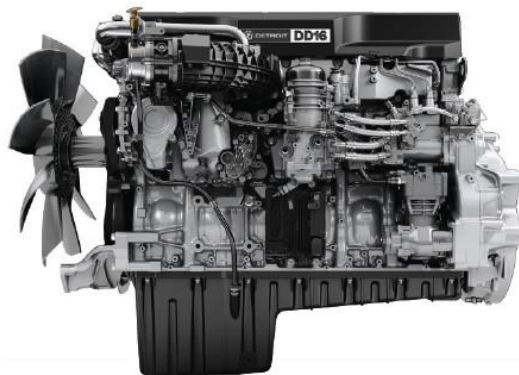

Engine Highlights

Displacement (L):	15.6
HP Range:	475 - 600
Torque Range (ft*lb):	1,850 - 2,050

OEM Highlights

Efficient engine that has power & performance.

- Amplified common rail system
- BlueTec emissions technology
- DDEC Electronics

Engine Volume

Model	Power (Hp)	Emission	CY 2013	CY 2014	CY 2015	CY 2016	CY 2017	CY 2018
15.6L 24v sohc L6	475 - 600	U.S. 10	11561	12248	12885	11159	10187	11962



MACK POWERTRAIN

MP7

Filters

Luberfiner Part Number	FRAM Part Number	Part Type	OE Number	Quantity	Comment
LFF3358	PS10678	Fuel	20539578	1	Water Separator w/bowl Opt.
LFF8059	P9629	Fuel	20539582	1	Sec. Spin-on
LFP3236	PH9376	Lube	485GB3236	2	Spin-on
LFW5141	PR9884	Coolant	20539991	1	
LFP8642	P9407	Lube	20843764	1	By-pass Spin-on



Engine Highlights	
Displacement (L):	10.8
HP Range:	325 - 405
Torque Range (ft*lb):	1,200 - 1,560
OEM Highlights	
Lightweight engine for weight sensitive applications.	
- Single overhead Camshaft	
- Variable geometry turbocharger	
- Power Leash engine brake	

Engine Volume

Model	Power (Hp)	Emission	CY 2013	CY 2014	CY 2015	CY 2016	CY 2017	CY 2018
10.8L 24v ohv L6	325 - 405	U.S. 10	11426	11825	12196	10312	9758	11791

Chassis



Mack Pinnacle



Mack Granite



Mack TerraPro



MACK POWERTRAIN

MP8

Filters

Luberfiner Part Number	FRAM Part Number	Part Type	OE Number	Quantity	Comment
LFF3358	PS10678	Fuel	20539578	1	Water Separator w/bowl Opt.
LFF8059	P9629	Fuel	20539582	1	Sec. Spin-on
LFP3236	PH9376	Lube	485GB3236	2	Spin-on
LFW5141	PR9884	Coolant	20539991	1	
LFP8642	P9407	Lube	20843764	1	By-pass Spin-on



Engine Highlights

Displacement (L):	12.8
HP Range:	390 - 485
Torque Range (ft*lb):	1,460 - 1,860

OEM Highlights

- Strong engine to handle heavy workloads.
- Single overhead Camshaft
- Variable geometry turbocharger
- Power Leash engine brake

Engine Volume

Model	Power (Hp)	Emission	CY 2013	CY 2014	CY 2015	CY 2016	CY 2017	CY 2018
12.8L 24v ohv L6	390 - 485	U.S. 10 / Euro IV	14584	15013	15227	13635	12858	14624

Chassis



Mack Pinnacle



Mack Granite



Mack TerraPro



MP10

Filters

Luberfiner Part Number	FRAM Part Number	Part Type	OE Number	Quantity	Comment
LFW5141	PR9884	Radiator Cooling Unit	20539991	1	w/Chemical
LFP3236	PH9376	Engine Oil Filter	20539275	2	
LFP8642	P9407	Lube	20843764	1	By-pass Spin-on
LFF3358	PS10678	Fuel Filter	21017305	1	Spin-on Water Separator
LFF8059	P9629	Fuel Filter	20972295	1	Spin-on

Chassis



Mack Titan



Engine Highlights

Displacement (L):	16.1
HP Range:	515 - 605
Torque Range (ft*lb):	1,860 - 2,060

OEM Highlights

Most powerful engine Mack has ever built.

- Single overhead Camshaft
- Variable geometry turbocharger
- Power Leash engine brake

Engine Volume

Model	Power (Hp)	Emission	CY 2013	CY 2014	CY 2015	CY 2016	CY 2017	CY 2018
16.1L 24v sohc L6	515 - 605	U.S. 10 / Euro IV	573	591	601	568	549	609



MAXXFORCE 7

Filters

Luberfiner Part Number	FRAM Part Number	Part Type	OE Number	Quantity	Comment
L5086F	CS10648	Fuel	1878042C91	1	Water Separator
LP2017	CH9549	Lube	1840752C91	1	
L8874FK	K10873	Fuel		1	

Chassis



International Terrastar



International Durastar



Engine Highlights

Displacement (L):	6.4
HP Range:	215 - 300
Torque Range (ft*lb):	560 - 660

OEM Highlights

- V8 turbo diesel designed for medium duty applications.
- High pressure common rail fuel system
 - Dual sequential turbochargers
 - Compacted graphite iron block

Engine Volume

Model	Power (Hp)	Emission	CY 2013	CY 2014	CY 2015	CY 2016	CY 2017	CY 2018
6.4L 32v ohv V8	215 - 300	U.S. 10	14275	15247	16811	18074	18810	19381



MAXXFORCE DT

Filters

Luberfiner Part Number	FRAM Part Number	Part Type	OE Number	Quantity	Comment
L5086F	CS10648	Fuel	1878042C91	1	
LFP9025	PH9971	Lube	1842639C91	1	



Engine Highlights

Displacement (L):	7.6
HP Range:	210 - 300
Torque Range (ft*lb):	560 - 860

OEM Highlights

- Durable engine providing performance & low ownership cost.
- High pressure common rail fuel system
 - Dual sequential turbochargers
 - Direct injection

Chassis



International Workstar



International Durastar

Engine Volume

Model	Power (Hp)	Emission	CY 2013	CY 2014	CY 2015	CY 2016	CY 2017	CY 2018
7.6L 24v dohc L6	210 - 300	U.S. 04 / U.S. 10	41723	44741	49282	52163	53035	55729



MAXXFORCE 9 & 10

Filters

Luberfiner Part Number	FRAM Part Number	Part Type	OE Number	Quantity	Comment
L5086F	CS10648	Fuel	1878042C91	1	
LFP9025	PH9971	Lube	1842639C91	1	



Engine Highlights

Displacement (L):	9.3
HP Range:	300 - 350
Torque Range (ft*lb):	860 - 1,150

OEM Highlights

- Increased displacement offers heavy duty engine performance.
- High pressure common rail fuel system
 - Dual sequential turbochargers
 - Direct injection

Chassis



International Workstar



International Durastar

Engine Volume

Model	Power (Hp)	Emission	CY 2013	CY 2014	CY 2015	CY 2016	CY 2017	CY 2018
9.3L 24v dohc L6	300 - 350	U.S. 10 / U.S. 04	16276	17114	20084	22397	23188	25608



NAVISTAR POWERTRAIN



MAXXFORCE 11

Filters

Luberfiner Part Number	FRAM Part Number	Part Type	OE Number	Quantity	Comment
L7694F	CS10853	Fuel	3004473C91	1	
LP7498XL	CH11782	Lube		1	
LP8213	P10634	Lube	2606467C91	1	By-pass



Engine Highlights

Displacement (L):	10.5
HP Range:	330 - 390
Torque Range (ft*lb):	1,250 - 1,450

OEM Highlights

A smooth & quiet engine with excellent power.

- High pressure common rail fuel system
- Dual sequential turbochargers
- Compacted graphite iron block

Engine Volume

Model	Power (Hp)	Emission	CY 2013	CY 2014	CY 2015	CY 2016	CY 2017	CY 2018
10.5L 24v sohc L6	330 - 390	U.S. 10	7968	8445	9270	9156	8915	10449

Chassis



International Workstar



International Prostar



International Paystar



International Terrastar



NAVISTAR POWERTRAIN



MAXXFORCE 13

Filters

Luberfiner Part Number	FRAM Part Number	Part Type	OE Number	Quantity	Comment
L7694F	CS10853	Fuel	3004473C91	1	
LP7498XL	CH11782	Lube		1	
LP8213	P10634	Lube	2606467C91	1	By-pass



Engine Highlights	
Displacement (L):	12.4
HP Range:	410 - 475
Torque Range (ft*lb):	1,450 - 1,700
OEM Highlights	
A smooth & quiet engine with excellent power.	
- High pressure common rail fuel system	
- Dual sequential turbochargers	
- Compacted graphite iron block	

Engine Volume

Model	Power (Hp)	Emission	CY 2013	CY 2014	CY 2015	CY 2016	CY 2017	CY 2018
12.4L 24v sohc L6	410 - 475	U.S. 10 / Euro IV	14206	14917	16631	16956	16802	19597

Chassis



International Workstar



International Prostar



International Paystar



International Terrastar



PX-7

Filters

Luberfiner Part Number	FRAM Part Number	Part Type	OE Number	Quantity	Comment
LFP3970	PH8942	Lube	3937736	1	



Engine Highlights

Displacement (L):	6.7
HP Range:	200 - 360
Torque Range (ft*lb):	520 - 800

OEM Highlights

- Medium duty engine built for superior performance.
- Variable Geometry turbocharger
 - SCR after treatment system
 - High pressure common rail system

Engine Volume

N/A

Chassis



Kenworth T370



Kenworth T270



Peterbilt 337



PACCAR POWERTRAIN

PX-9

Filters

Luberfiner Part Number	FRAM Part Number	Part Type	OE Number	Quantity	Comment
LFP3000XL	HPH9500	Lube	3401544	1	



Engine Highlights

Displacement (L):	8.9
HP Range:	260 - 450
Torque Range (ft*lb):	720 - 1,250

OEM Highlights

- Heavy duty engine with high power-to-weight ratio.
- Variable Geometry turbocharger
 - SCR after treatment system
 - High pressure common rail system

Engine Volume

N/A

Chassis



Peterbilt 384



Peterbilt 382



Kenworth T370



Kenworth T270



MX-13

Filters

Luberfiner Part Number	FRAM Part Number	Part Type	OE Number	Quantity	Comment
LP6043		Lube	1643070	1	
LP8213	P10634	Lube	1643072	1	Centrifuge By-pass
LFW4686XL	PR11081	Coolant		1	
L5094F		Fuel		1	Fuel Water Separator
LFF6289		Fuel		1	



Engine Highlights

Displacement (L):	12.9
HP Range:	380 - 485
Torque Range (ft*lb):	1,450 - 1,850

OEM Highlights

Efficient engine built for heavy duty applications.

- Integrated lube module
- Single overhead CAM
- High pressure common rail system

Engine Volume

Model	Power (Hp)	Emission	CY 2013	CY 2014	CY 2015	CY 2016	CY 2017	CY 2018
12.9L 24v ohv L6	380 - 485	U.S. 10 / U. S. 07	20705	21499	22291	19656	17894	20978

Chassis



Peterbilt 579



Peterbilt 384



Kenworth T700



Kenworth W900



VOLVO POWERTRAIN

D11

Filters

Luberfiner Part Number	FRAM Part Number	Part Type	OE Number	Quantity	Comment
LFF8059	P9626	Fuel	20430751	1	
LFP3191	PH8842, PH49A	Lube	4787362	2	
LFP8642	P9407	Lube	4775565	1	By-pass
LFW5875	PR8591	Coolant	20458769	1	Listed



Engine Highlights

Displacement (L):	10.8
HP Range:	325 - 405
Torque Range (ft*lb):	1,250 - 1,550

OEM Highlights

Lightweight engine built for reliability and cost of operation.

- Warmhold function
- Fuel system temperature regulator
- Air intake pre-heater

Engine Volume

Model	Power (Hp)	Emission	CY 2013	CY 2014	CY 2015	CY 2016	CY 2017	CY 2018
10.8L 24v sohc L6	325 - 405	U.S. 10	2318	2394	2458	2072	2009	2351

Chassis



Volvo VHD 200



Volvo VNM 630



Volvo VNL 300



Volvo VNL 630



D13

Filters

Luberfiner Part Number	FRAM Part Number	Part Type	OE Number	Quantity	Comment
LFF8059	P9626	Fuel	20430751	1	
LFP3191	Ph8842, PH49A	Lube	4787362	2	
LFP8642	P9407	Lube	4775565	1	By-pass
LFW5141	PR9884	Coolant	20539991	1	Not listed



Engine Highlights

Displacement (L):	12.8
HP Range:	375 - 500
Torque Range (ft*lb):	1,450 - 1,850

OEM Highlights

- Fuel Efficient, powerful & lightweight EPA compliant engine.
- Warmhold function
- Fuel system temperature regulator
- Air intake pre-heater

Engine Volume

Model	Power (Hp)	Emission	CY 2013	CY 2014	CY 2015	CY 2016	CY 2017	CY 2018
12.8L 24v sohc L6	375 - 500	U.S. 10	25075	26035	26878	22781	22145	25885

Chassis



Volvo VHD 200



Volvo VNM 630



Volvo VNL 730



Volvo VNL 780



D16

Filters

Luberfiner Part Number	FRAM Part Number	Part Type	OE Number	Quantity	Comment
LFF8059	P9626	Fuel	20430751	1	Spin-on
LFP3191	PH8842, PH49A	Lube	478736	2	Spin-on
LFP8642	P9407	Lube	477556	1	Spin-on By-pass
LFW5875	PR8591	Coolant	3945411	1	Listed



Engine Highlights

Displacement (L):	16.1
HP Range:	450 - 600
Torque Range (ft*lb):	1,650 - 2,050

OEM Highlights

- Ultra-reliable engine that delivers power and torque.
- Warmhold function
- Fuel system temperature regulator
- Air intake pre-heater

Engine Volume

Model	Power (Hp)	Emission	CY 2013	CY 2014	CY 2015	CY 2016	CY 2017	CY 2018
16.1L 24v sohc L6	450 - 600	U.S. 10	389	401	423	346	330	388

Chassis



Volvo VNL 300



Volvo VNX



Volvo VNL 730



Volvo VNL 780

