

Catalogue de pièces *Master Catalogue*

FleetSpec



Camion et Remorque **Heavy Duty Truck and Trailer**

www.fleetspec.com
info@fleetspec.com

Table des matières / Table of Contents

1	Freins à ressort et cylindres de frein / Spring Brake & Brake Chambers	
	Sealed Units	7
	Piggyback Plus Kits	8
	Service Chambers	9
	Clevis and Pins	10
	Replacement Parts	12
	Diaphragms	14
2	Leviers d'ajustement / Slack Adjusters	
	Meritor Manual Slack Adjusters	17
	Meritor ASA	18
	Bendix ASA	20
	Gunite ASA	21
	Haldex ABA	22
	Stemco/Crewson ASA	24
3	Dessicateurs d'air / Air Dryers	
	Bendix AD-IP	28
	AD-IS	30
	AD-SP	31
	AD-2	32
	AD-4	33
	AD-9	34
	Wabco	38
	CR / Midland / SKF / Alcohol Evaporator	40
4	Soupapes - freins à air / Air Brake System Valves	
	Bendix BP-1 / BP-R1 / DC-4	45
	D-2 / DV-2	46
	E-3 -4 -5 -6 -7 -8P -10 -10P -12 -14	47
	LP-3 / LQ-2 -4 -5	50
	MV-2 -3	51
	PP-1 -2 -3 -7 -8 -DC	54
	PR-2 -3 -4	57
	QR-1 -N -1C -L	58
	R-6 -7 -8 -8P -10 -12 - 12DC -12H -12P -14 -14H	59
	RE-4 -6 -6NC	64
	RD-3	65
	RV-1 / SC-3 / SL-4	66
	SR-1 -2 -4 -5 -7	67
	ST-1 -3 -4 / SV-1	70
	TC-2 -7	71
	TP-2 -3 -3DC -4 -5	72
	TR-2 -3	74
	TW-1 -2 -3 -4	74
	Haldex/Berg	76
	Haldex/Midland One Way Check	78
	Foot Valves	78
	FF-2	79
	Inversion / Dash Module	79
	Quick Release / Relay Valves / RG-2 / RG-5	80
	RT-4 / Trailer Brake Control	83
	Tractor Protection Valves / Double Flipper	84

Table des matières / Table of Contents

	Haldex/Wagner Valves	86
	Kelsey Hayes Valves	87
	Sealco Pressure Protection / Quick Release / Supply Line Filter	88
	Relay Valves	89
	Auto Reset Control Valve / Hand Control Valves	91
	Relay Emergency Valves / Spring Brake Valves / Foot Valve	92
	Tramec TEV.....	95
	Williams Air System Valves	96
	FleetSpec Check / Drain / Safety Valves	102
5	Système de freins ABS / Anti-Lock Brake System	
	ABS Sensors & Cables	104
	Bendix ATR-6, M-21 and M-32 Valves	108
	Haldex FFABS and ABS Relay Valves	110
	Wabco Tractor ABS (Rear) Valve Package	112
	Tractor ABS/ATC (Rear) Valve Package	114
	Tractor ABS (Front) Valve Package	116
	Tractor ABS Modulator Valves	117
	Trailer ECU Modulator Valve Assemblies	118
	Trailer ABS Modulator Valves	122
6	Soupapes de suspension à air / Suspension Air Valves	
	Height Control Valves and Linkages	127
	Control Valves, Ride-Air compatible	134
	Norgren compatible	140
	Schrader compatible	144
	Others	145
	Pressure Protection Valves	148
	Hand control Valves	149
	Pilot Valves	150
	Solenoids & Relay Valves	151
	Regulators & Gauges	152
	Control Boxes, Empty and Loaded	154
7	Soupapes à fonctions diverses / Miscellaneous Air Valves	
	Transmission Shift / Range Valves	171
	Dump Truck Rear Door Valves	172
	Tailgate Control Valves	173
	Air Cylinder Valves	173
	Toggle Air Valves	174
	Regulators	174
8	Têtes d'accouplement & accessoires / Gladhands & Air Accessories	
	Gladhand Seals & Gladhands	179
	Grip Extensions, In-Line Quick Release	182
	Support Springs, Gladhand Lock	184
	Hose Separators , Hose Clamps	185
9	Accessoires électriques / Electrical Accessories	
	Axle Valve	189
	Electro-Pneumatic Switches	189
	Junction Boxes	190

Table des matières / Table of Contents

10 Accessoires de camion & remorque / Truck & Trailer Accessories

Wheel Spacers	195
Hub Caps	196
Dock Bumpers	198
Wheel Chocks	200
Cargo Straps	201
Document Holders	201
King Pin Lock	202

Appendix

Termes & conditions / Terms & Conditions	207
Politique pour les noyaux / Core policy	208
Garantie / Warranty Policy	209
Référence d'interchange pour les soupapes à air / Air Valve Crossover Reference	210

Liste numérique des pièces / Numerical Index	215
--	-----



Section 1

Freins à ressort et cylindres de frein
Spring Brake and Brake Chambers

Section 1 .Freins à ressort .Spring Brakes

WARRANTY POLICY

Warranty

FleetSpec, a division of 3287581 Canada Inc., Montreal Qc., Canada, warrants that all spring brakes and service chambers, when properly installed and placed under normal service and use as truck or trailer air brake actuators, are free from defects in material and workmanship for three years from the date of manufacture stamped on the product. The warranty period applies irrespective of mileage.

Limitation of warranty

1. This warranty is invalid if the spring brakes or service chambers have been subjected to abuse, misuse, improper installation, abnormal service, accident, road debris, fire, repair, tampering or use in a non-standard vehicle application that had not been pre-approved by **FleetSpec** prior to installation. Unauthorized repairs or modifications will void this limited warranty.
2. In no event and under no circumstances shall **FleetSpec** be responsible under this limited warranty for any other charges whatsoever, including but not limited to charges or claims for labor, lost business, lost time, lost profits, loss of use, or any consequential damages, however denominated or described. The remedy under this warranty is limited to repair or replacement, at **FleetSpecs'** option, of the defective spring brake or service chamber.
3. This warranty applies exclusively to **FleetSpec** spring brakes and service chambers sold for use within the North American market.

Disclaimer of other warranties

This warranty is in lieu of all other warranties either expressed or implied. All other warranties, expressed or implied, including any warranty of merchantability of fitness for a particular purpose, are hereby excluded.

Procedure for warranty claims

Product claimed defective must be returned freight prepaid to **FleetSpec** within 30 days from the date the defect is first detected. Upon receipt of the alleged defective spring brake or service chamber, **FleetSpec** shall examine it and, if **FleetSpec** agrees that the spring brake or service chamber is defective in materials or workmanship, within the warranty period, **FleetSpec** will repair or replace, and return it to the customer. If the spring brake or service chamber does not meet the requirements of our Warranty Policy as described above, at the customer's choice, the unit will be returned freight collect, repaired at the customer's cost or disposed of by **FleetSpec**.

Section 1 .Freins à ressort
 •Spring Brakes

Unités scellés
Sealed Units

New	Stroke	Pushrod Length	Thread Length	Port Boss	Notes
FS-5606	2.5"	13-1/2"	10-1/2"	Round	Standard stroke, Standard pushrod
FS-5606INT	2.5"	13-1/2"	10-1/2"	Round	Standard stroke, casings rotated for Intraax (Fig. 1)
FS-5606-18	2.5"	18"	11"	Round	Standard stroke, Extended pushrod
FS-5606-18INT	2.5"	18"	11"	Round	Standard stroke, Extended pushrod, casings rotated for Intraax (Fig. 1)
FS-5606L	3"	13-1/2"	10-1/2"	Square	Long stroke, Standard pushrod
FS-5606L-INT	3"	13-1/2"	10-1/2"	Square	Long stroke, Standard pushrod, casings rotated for Intraax (Fig. 1)
FS-5606L-18	3"	18"	11"	Square	Long stroke, Extended pushrod, for Intraax
FS-5606L-18INT	3"	18"	11"	Square	Long stroke, Extended pushrod, casings rotated for Intraax (Fig. 1)
FS-5606L-WY	3"	5-1/8"	Fig. 2	Square	Long stroke, with Yoke welded on. for Freightliner & International trucks.

Above units are Type 30/30. All units supplied with Clevis, and Release Stud.

FS-5624 (Type 24/30)	2.5	13-1/2"	10-1/2"	Round	Standard stroke, Standard pushrod (Fig. 3)
-------------------------	-----	---------	---------	-------	--

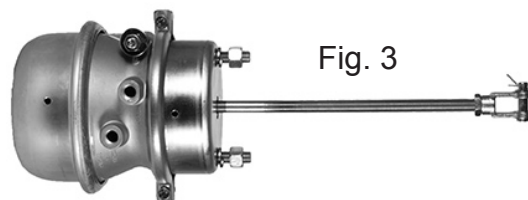
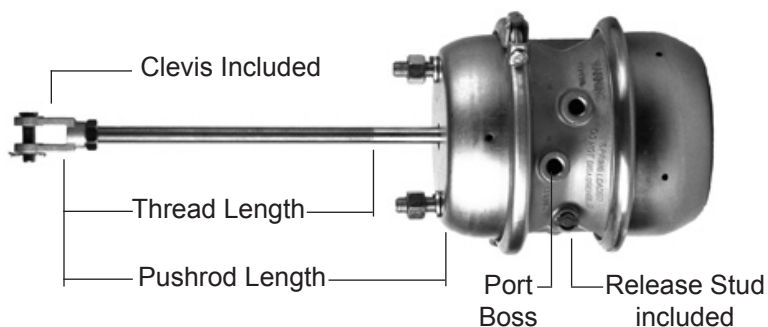
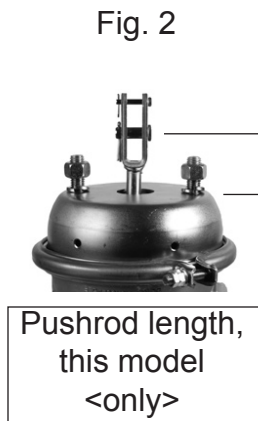

Section 1 .Freins à ressort .Spring Brakes

Ensembles d'actionneur de frein combinés Piggyback Plus Kits



New	Notes
FS-5608P	30/30 Piggyback Plus Kit, for Standard Stroke
** Comes Caged & individually boxed, with a FS-5606CW Wide Lip Clamp assembly.	



New	Notes
FS-5608PL	30/30 Piggyback Plus Kit, for Long Stroke
** Comes Caged & individually boxed, with a FS-5606CW Wide Lip Clamp assembly.	

Section 1 .Freins à ressort
 •Spring Brakes

**Cylindres de frein
 Service Chambers**

New	Unit Size	Stroke	Housing Depth	Pushrod		Mounting		Fig.
				Length (no air)	Thread UNF	Thread UNC	Spacing C to C	
FS-5001	9	1.75"	3-1/2"	10-1/2"	1/2"-20	7/16"-14	3"	1
FS-5002	12	1.75"	3-3/4"	10-1/2"	1/2"-20	7/16"-14	3"	1
FS-5003	16	2.25"	3-11/16"	10-1/2"	1/2"-20	7/16"-14	3"	2
FS-5003L	16LS	2.50"	4"	10-1/2"	5/8"-18	5/8-11	4-3/4"	3
FS-5004	20	2.25"	4-5/16"	10-1/2"	5/8"-18"	5/8-11	4-3/4"	4
FS-5004L	20LS	2.50"	4-5/16"	10-1/2"	5/8"-18"	5/8-11	4-3/4"	4
FS-5005	24	2.50"	4"	10-1/2"	5/8"-18	5/8-11	4-3/4"	5
FS-5005L	24LS	3.0"	4-1/2"	10-1/2"	5/8"-18	5/8-11	4-3/4"	5
FS-5006	30	2.50"	4-1/4"	10-1/2"	5/8"-18	5/8-11	4-3/4"	5
FS-5006L	30LS	3.0"	4-1/2"	10-1/2"	5/8"-18	5/8-11	4-3/4"	6
FS-5007	36	3.0"	5"	10-1/2"	5/8"-18	5/8-11	4-3/4"	7

Notes: All chambers feature fully threaded pushrods, and (2) 3/8" NPT air fittings

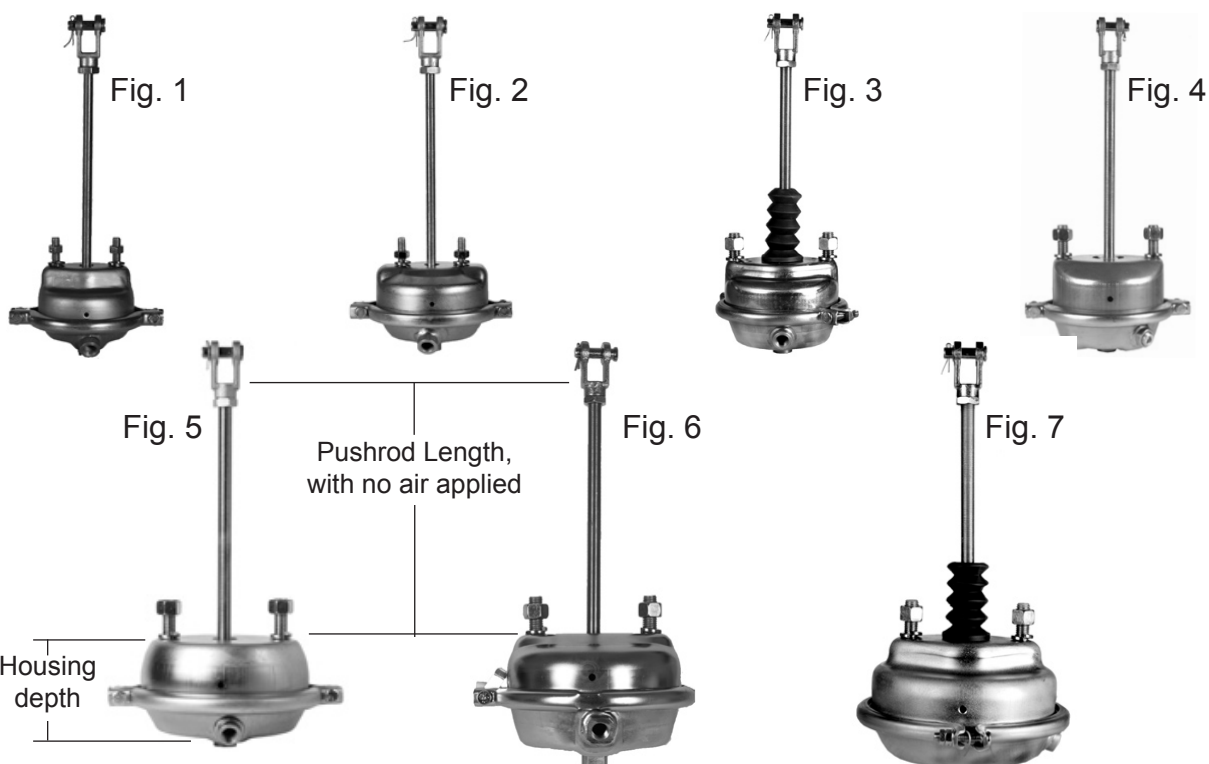

Propriété exclusive de FleetSpec. Toute reproduction interdite. / Exclusive property of FleetSpec. Reproduction prohibited.

Section 1 .Freins à ressort .Spring Brakes

Ensembles de chape Clevis Assemblies

ArvinMeritor ASA

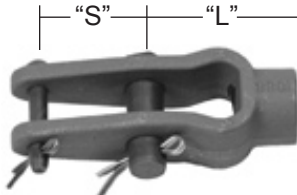

FS-R810019
 shown here



New	Thread	Length "L"	Length "S"
FS-R810019	5/8"	1-15/16"	1-3/8"
FS-R810019GP	As above, with Greasable Pins		
FS-R810021*	5/8"	1-3/4"	1-3/8"
FS-R810021GP*	As above, with Greasable Pins		
* For Long Stroke applications			
Clevis Assy's supplied with 1/2" and 1/4" Pins			
FS-R810019LP		Large Pin <only> Replaces: R801732	
FS-R810019SP		Small Pin <only> Replaces: R801730	
FS-R810005		Pin Kit (with Cotter Pins)	

Bendix ASA

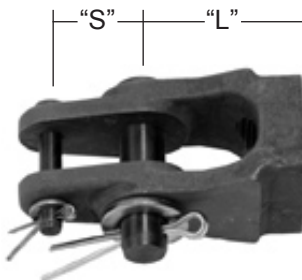

New	Thread	Length "L"	Length "S"
FS107158N	**	1-3/4"	1"
Supplied with both 1/2" and 1/4" Pins ** threaded for "Easy-On" standard adapter			
FS291452N	5/8 - 18 "Easy-On" Standard Adapter		

Stemco/Crewson "Auto-Check"

FS-MC8420KTA (Standard)



FS-MC8480KTA (Extended)



New	Thread	Length "L"	Length "S"
FS-MC8420KTA	5/8"	1-15/16"	1-3/8"
FS-MC8480KTA	5/8"	2-1/4"	1-3/8"
Clevis Assy's supplied with 1/2" and 1/4" Pins			
FS-MC8420LP		Large Pin <only>	
FS-MC8420SP		Small Pin <only>	
FS-MC8056KTA		Kit, both Pins, with Cotter pins	

Propriété exclusive de FleetSpec. Toute reproduction interdite. / Exclusive property of FleetSpec. Reproduction prohibited.

Section 1 .Freins à ressort
 •Spring Brakes

**Ensembles de chape
 Clevis Assemblies**

New	Thread	Length "L"	Length "S"
FS-GUAS3000	5/8"	1-3/4"	1-1/8"
FS-GUAS3000GP	As above, with Greasable Pins		
Supplied with both 1/2" and 1/4" Pins			
FS-GUAS3000LP	Large Pin <only>		
FS-GUAS3000SP	Small Pin <only>		

Gunite ASA (Threaded Clevis)

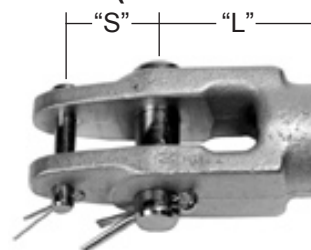

Gunite ASA (Collar Lock Clevis)

New	Description
FS-GUAS3016	Collar Lock Clevis (5/8") for Gunite
FS-GUAS3016GP	As above, supplied with Greasable Pins
FS-GUAS3018	Extended Collar Lock Clevis (5/8") for Gunite
FS-GUAS3018GP	As above, supplied with Greasable Pins
FS-GUAS3019	Collar Lock Clevis (1/2" or 5/8") for Gunite
FS-GUAS3019GP	As above, supplied with Greasable Pins
FS-GUAS4004	6 Large and 6 Small Pins, with Cotter Pins



Collar Lock Clevis
 illustrated here



Extended Collar Lock Clevis
 illustrated here

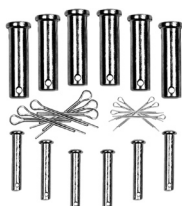

FS-GUAS4004
 Pin Kit
 illustrated here

Section 1 .Freins à ressort · Spring Brakes

Ensembles de chape Clevis Assemblies

FS-5082A
 shown

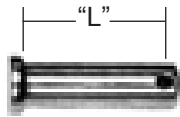
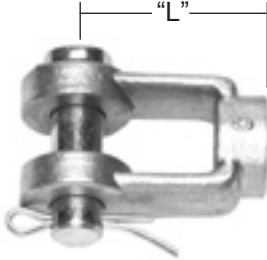

New	Thread	Pin Dia.	Length "L"
FS-5081	1/2"	1/2"	1-3/4"
FS-5082A	5/8"	1/2"	1-7/8"
FS-5083A	5/8"	5/8"	1-7/8"
FS-5076	<Pin>	1/2"	1-1/2"
FS-5077A	<Pin>	5/8"	1-3/8"

Axes de chape graissable Greaseable Clevis Pins

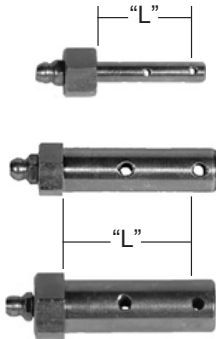

New	Pin Dia.	Length "L"
GCP1014	1/4"	1-1/8"
GCP1012	1/2"	1-1/2"
GCP1058	5/8"	1-1/2"

Improves serviceability of Spring Brake Clevises, for longer Slack Adjuster Bushing life, and ease of maintenance.

Pare-poussière Dust Boot



New	Notes
FS-5584	Pushrod Dust Boot - Fits all

Tiges de poussoir de remplacement Replacement Pushrods



New	Unit Size	Thread	Notes
FS-5019	30	5/8"	Standard 13-1/2" Pushrod
FS-5019-18	30	5/8"	Extended 18" Pushrod
FS-5019-22	30	3/4"	Extended 22" Pushrod

Section 1 .Freins à ressort .Spring Brakes

Ressort de remplacement Replacement Spring

New	Notes
FS-5012	Service Return Spring for 30/30 Standard or Long Stroke



Coques de remplacement Replacement Non-Pressure Housings

New	Unit Size	Notes
FS-5040	30	Replacement Housing for 30/30 Standard Stroke
FS-5040L	30	Replacement Housing for 30/30 Long Stroke



Serre-joints à sangle de remplacement Replacement Clamp Bands

New	Unit Size	Notes
FS-5606C	30	Clamp Band Ass'y, Standard Lip
FS-5606CE	30	Clamp Band, economy style
FS-5606CW	30	Clamp Band Ass'y, Wider Lip
FS-5042	n/a	Replacement Clamp Nut & Bolt

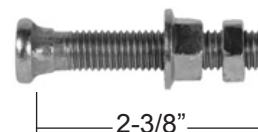

Goujon de relâche de remplacement Replacement Release Stud

New	Notes
FS-5620LS	Replacement Release Stud, for 30/30 Standard or Long Stroke

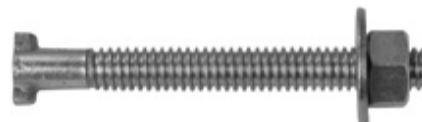

New	Notes
FS-5606R	Replacement Release Stud Plug



Section 1 .Freins à ressort
 .Spring Brakes

Membranes de remplacement
Replacement Diaphragms



New	Unit Size	Notes
FS-5001D	9	Diaphragm <only>, Standard Stroke
FS-5002D	12	Diaphragm <only>, Standard Stroke
FS-5003D	16	Diaphragm <only>, Standard Stroke
FS-5004D	20	Diaphragm <only>, Standard Stroke
FS-5005D	24	Diaphragm <only>, Standard Stroke
FS-5006D	30	Diaphragm <only>, Standard Stroke
FS-5007D	36	Diaphragm <only>, Standard Stroke



New	Unit Size	Notes
FS-5004DL	20LS	Diaphragm <only>, Long Stroke
FS-5005DL	24LS	Diaphragm <only>, Long Stroke
FS-5006DL	30LS	Diaphragm <only>, Long Stroke



Section 2

Leviers d'ajustement
Slack Adjusters

Section 2 .Leviers d'ajustement
 .Slack Adjusters

**Leviers d'ajustement manuel
 Manual Slack Adjusters**

MSA

New	Splines	Arm Length			Compatible with
		"A"	"B"	"C"	
MSA824000	1-1/2 - 10	7"	6"	5"	Bendix 278323N, Haldex KN47001, Meritor 824000
MSA824001	1-1/2 - 10	6-1/2"	5-1/2"	--	Bendix 278321, Haldex KN47011, Meritor 824001
MSA824003	1-1/2 - 28	7"	6"	5"	Bendix 288282, Haldex KN44041, Meritor 824003
MSA824004	1-1/2 - 28	6-1/2"	5-1/2"	--	Bendix 288753N, Haldex KN44061, Meritor 824004
MSA24007	1-37/64 - 37	6"	--	--	Bendix 283411, Haldex KN44041, Meritor 824007

MAXIMUM Torq Rating is 22,000 LBS

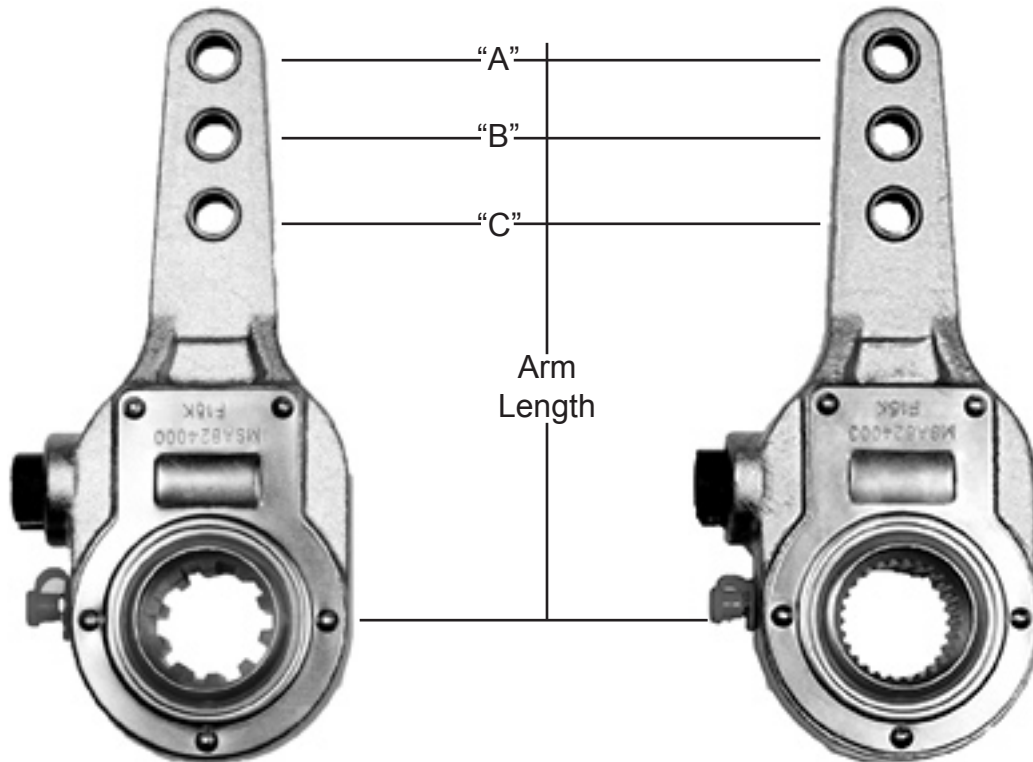

Section 2 .Leviers d'ajustement
· Slack Adjusters

ASA

**Leviers d'ajustement automatiques
Automatic Slack Adjusters**

New	Spline	Arm Length	Compatible with
FS-R801041	1-1/2 - 10	5-1/2"	R802290, R802291, R802292, R802293, R802300 R802301, R802310, R802311, R801041
FS-R801042	1-1/2 - 10	6"	R801040, R802354, R802355, R801042, R802356 R802357, R801044
FS-R801073	1-1/2 - 28	5-1/2"	R802440, R802441, R801072, R801073, R802444, R802445, A24-2275-H-1152, A32-3275-H-1152
FS-R801074	1-1/2 - 28	6"	R801071, R801074, R802490, R802491, R801075

All units are Type 3, "unhanded"
All units are supplied with a FS-R810019 Clevis

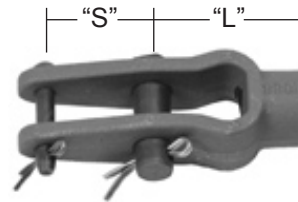
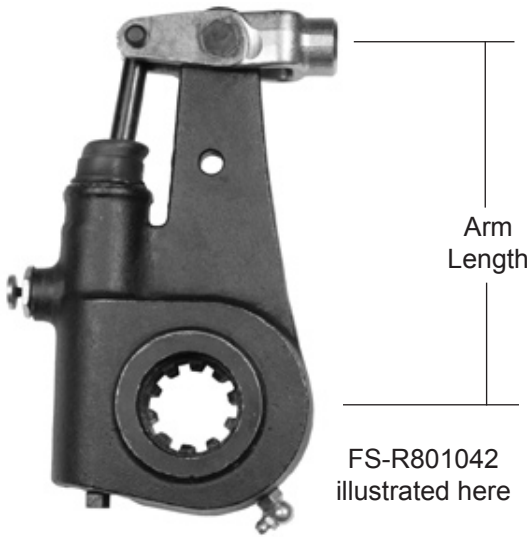

FS-R810019
illustrated here

New	Thread	Length "L"	Length "S"
FS-R810019	5/8"	1-15/16"	1-3/8"
FS-R810019GP	As above, with Greasable Pins		
FS-R810021*	5/8"	1-3/4"	1-3/8"
FS-R810021GP*	As above, with Greasable Pins		
* For Long Stroke applications			
Clevis Assy's supplied with 1/2" and 1/4" Pins			
FS-R810019LP	Large Pin <only> Replaces: R801732		
FS-R810019SP	Small Pin <only> Replaces: R801730		
FS-R810005	Pin Kit (with Cotter Pins)		

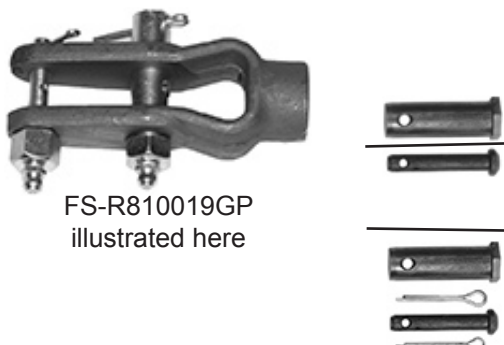

Section 2 .Leviers d'ajustement
 •Slack Adjusters

Leviers d'ajustement automatiques
Automatic Slack Adjusters

ASA

New	Spline	Arm Length	Application
FS-R802446	1-1/2 - 28	5-1/2"	Steer / Drive / Trailer axle
FS-R802486	1-1/2 - 28	6"	Steer / Drive / Trailer axle
Both units are Type 1, "Left Hand". Both units are supplied with a FS-R810019 Clevis			

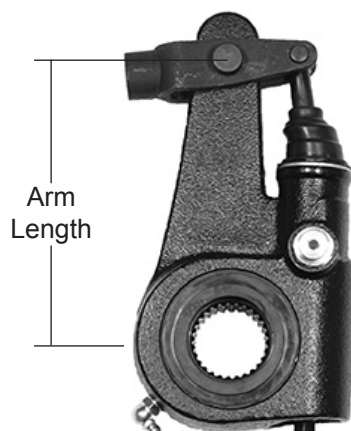

FS-R802446
 illustrated here

New	Spline	Arm Length	Application
FS-R802447	1-1/2 - 28	5-1/2"	Steer / Drive / Trailer axle
FS-R802487	1-1/2 - 28	6"	Steer / Drive / Trailer axle
Both units are Type 2, "Right Hand". Both units are supplied with a FS-R810019 Clevis			

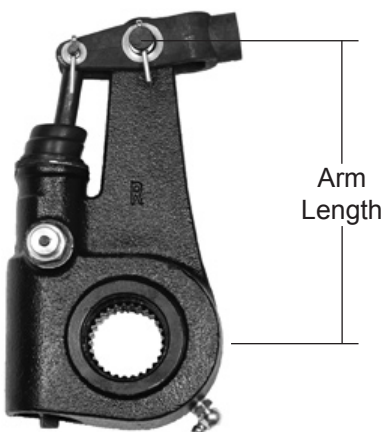

FS-R802487
 illustrated here

Section 2 : Leviers d'ajustement Slack Adjusters

ASA-5

Leviers d'ajustement automatiques Automatic Slack Adjusters

New	Spline	Arm Length	Replaces Bendix #
FS065175N	1-1/2 - 28	6"	K043877
FS065179N	1-5/8 - 37	6"	065177
FS065247N	1-1/2 - 28	5-1/2"	K043197
FS065344N	1-1/2 - 10	6"	K041876
FS065700N	1-1/2 - 10	5-1/2"	K041870
All units supplied with Straight Yokes, and 5/8-18 "Easy-On" Standard Adapters			

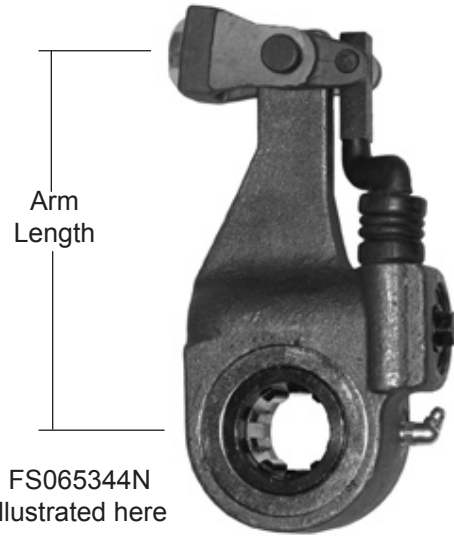

New	Notes
FS291452N	5/8 - 18 "Easy-On" Standard Adapter

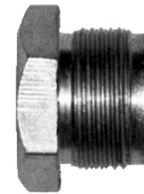

New	Notes
FS107158N	"Easy-On" Straight Yoke Kit



Section 2 : Leviers d'ajustement Slack Adjusters

Leviers d'ajustement automatiques Automatic Slack Adjusters

ASA

FleetSpec #	Spine	Arm Length	Supplied Clevis	Replaces Gunite #
FS-GUAS1132	1-1/2 -10	5-1/2"	FS-GUAS3019	AS1132
FS-GUAS1133	1-1/2 - 10	6"	FS-GUAS3016	AS1133
FS-GUAS1136	1-1/4 - 10	5-1/2"	FS-GUAS3019	AS1136
FS-GUAS1140	1-1/2 - 28	5-1/2"	FS-GUAS3019	AS1140
FS-GUAS1141	1-1/2 - 28	6"	FS-GUAS3016	AS1141
FS-GUAS1147	1-1/2 - 10	6"	FS-GUAS3018	AS1147

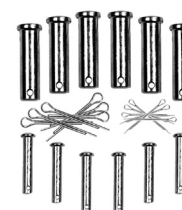
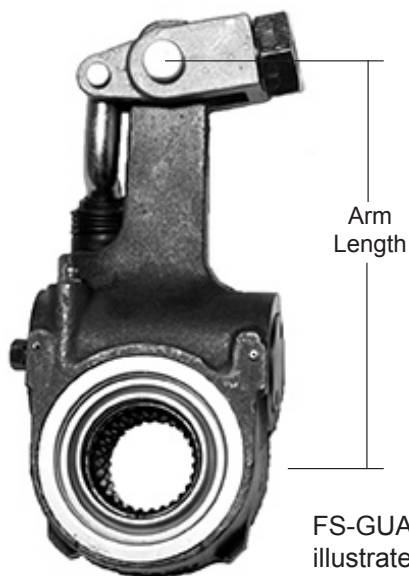

FS-GUAS4004
 Pin Kit
 illustrated here



Extended Collar Lock Clevis
 illustrated here



Collar Lock Clevis
 illustrated here

New	Description
FS-GUAS3016	Collar Lock Clevis (5/8") for Gunite
FS-GUAS3016GP	As above, supplied with Greasable Pins
FS-GUAS3018	Extended Collar Lock Clevis (5/8") for Gunite
FS-GUAS3018GP	As above, supplied with Greasable Pins
FS-GUAS3019	Collar Lock Clevis (1/2" or 5/8") for Gunite
FS-GUAS3019GP	As above, supplied with Greasable Pins
FS-GUAS4004	6 Large and 6 Small Pins, with Cotter Pins

Propriété exclusive de FleetSpec. Toute reproduction interdite. / Exclusive property of FleetSpec. Reproduction prohibited.

Section 2 : Leviers d'ajustement Slack Adjusters

ABA

Leviers d'ajustement automatiques Automatic Slack Adjusters

New	Spline	Arm Length	Installation Kit (included)	Application	Fig.
F400-D10140	1-1/2 - 28	5" or 6"	F42710553	"Standard"	1
F400-D10141	1-1/2 - 28	5-1/2" or 6-1/2"	F42710553	"Standard"	1
F400-D10143	1-1/2 - 10	5-1/2" or 6-1/2"	F42710553	"Standard"	1
F400-D10144	1-1/2 - 28	6"	F42710566	Mack Truck	2
F400-D10155	1-1/2 - 10	5-1/2"	F42710554	Kenworth 8-Bag Air Ride	5
F400-D10211	1-1/2 - 28	5-1/2"	F42710563	Trailer, 16-1/2" brake assy.	3
F400-D10212	1-1/2 - 28	6"	F42710563	Trailer, 16-1/2" brake assy.	3
F400-D10215	1-1/2 - 10	5-1/2"	F42710563	Trailer, 16-1/2" brake assy.	3
F400-D10216	1-1/2 - 10	6"	F42710563	Trailer, 16-1/2" brake assy.	3
F400-D10305	1-1/2 - 28	6"	F42710563	Trailer, 12-1/4" brake assy.	4
F400-D10306	1-1/2 - 10	6"	F42710563	Trailer, 12-1/4" brake assy.	4

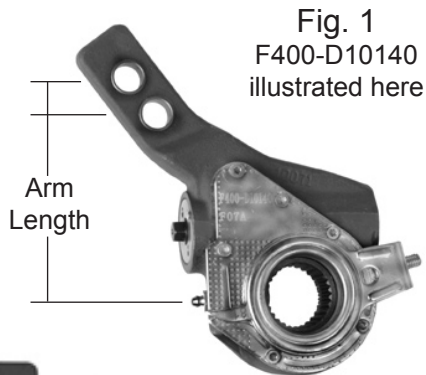

Fig. 1
F400-D10140
illustrated here



Fig. 2
F400-D10144
illustrated here



Fig. 3
F400-D10211
illustrated here

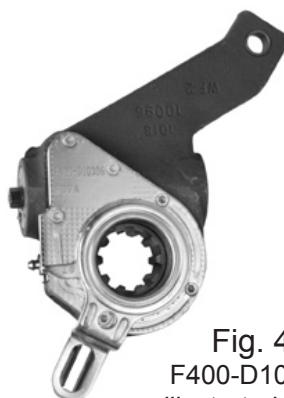

Fig. 4
F400-D10306
illustrated here

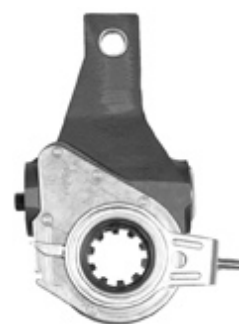

Fig. 5
F400-D10155
illustrated here

Section 2 : Leviers d'ajustement Slack Adjusters

Pièces de remplacement Replacement Parts

New	Notes
F42710553	Installation Kit

New	Notes
F42710554	Installation Kit

New	Notes
F42710563	Installation Kit

New	Notes
F42710566	Installation Kit

Ensemble de goujon Stud Kit

New	Notes
F42710558	Parts to service 4 ABA units

New	Notes
F44310318K	Kit of Single Stud, Nut, and Bushing

Coussinet d'axe de chape Clevis Bushings

New	Notes
FS-432	1/2" ID x 5/8" OD (Haldex 45210058)
FS-433	1/2" ID x 3/4" OD (Haldex 45210094)
FS-434	5/8" ID x 13/16" OD (Haldex 45210128)

Coussinet rectangulaire Rectangular Bushing

New	Notes
F45210125	1-1/4" x 3/4"

ABA



Section 2 : Leviers d'ajustement Slack Adjusters

ASA

Leviers d'ajustement automatiques Automatic Slack Adjusters

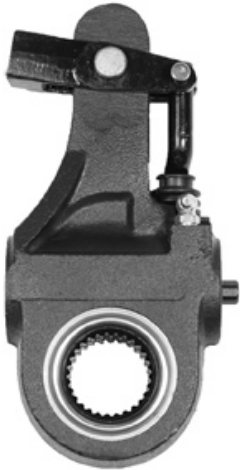

FS-MK22153S
shown here

FS-MK41106SE
shown here



New	Spline	Arm	Notes
WITHOUT Stroke Indicator, 5/8" Clevis			
FS-MK21106S	1-1/2 - 10	6"	Repl: Stemco MK21106S
FS-MK22100S	1-1/2 - 28	5-1/2"	Repl: Stemco MK22100S
FS-MK22106S	1-1/2 - 28	6"	Repl: Stemco MK22106S
FS-MK22153S	1-1/2 - 28	5" or 6"	12-1/4" S Cam Repl: Stemco MK22153S
for STANDARD STROKE Spring Brakes, WITH Stroke Indicator, and 5/8" Extended Clevis			
FS-MK41106SE	1-1/2 - 10	6"	Repl: Stemco MK41106S Stemco MK41706S
FS-MK42100SE	1-1/2 - 28	5-1/2"	Repl: Stemco MK42100S Stemco MK42700S
FS-MK42106SE	1-1/2 - 28	6"	Repl: Stemco MK42106S Stemco MK42706S
for LONG STROKE Spring Brakes WITHOUT Welded Yokes WITH Stroke Indicator, and 5/8" Extended Clevis			
FS-MK71106SE	1-1/2 - 10	6"	Repl: Stemco MK71106S Stemco MK71706S
FS-MK72100SE	1-1/2 - 28	5-1/2"	Repl: Stemco MK72100S Stemco MK72700S
FS-MK72106SE	1-1/2 - 28	6"	Repl: Stemco MK72106S Stemco MK72706S

"Votre source pour tous vos pièces neuves et remanufacturées depuis 1996"
 "Your trusted source for quality New & Reman air components since 1996"

Compatible avec
 Compatible with

**Stemco /
 Crewson**

Section 2 .Leviers d'ajustement
 ·Slack Adjusters

**Pièces de remplacement
 Replacement Parts**

ASA

New	Thread	Length "L"	Length "S"
FS-MC8420KTA	5/8"	1-15/16"	1-3/8"
FS-MC8480KTA	5/8"	2-1/4"	1-3/8"
Clevis Assy's supplied with 1/2" and 1/4" Pins			
FS-MC8420LP		Large Pin <only>	
FS-MC8420SP		Small Pin <only>	
FS-MC8056KTA		Kit, both Pins, with Cotter pins	

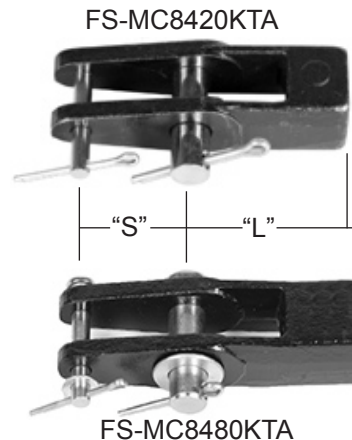
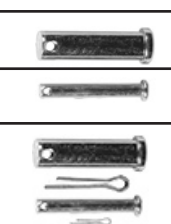

Notes



Section 3

Dessicateurs d'air
Air Dryers

Section 3 .Dessicateurs d'air · Air Dryers

AD-IP

Dessicateur d'air Air Dryer



FS109477X shown here



Drop-in modifications:
 * Integral External Check Valve
 * Integral "make-Up" Line
 * Delivery Port, with special Fitting
 For use with Wabco/Holset single cylinder model E or QE compressors

Complete Air Dryer New, with bracket	Complete Air Dryer Reman, with bracket	Complete Air Dryer Reman, NO bracket	Heater Voltage	Notes
FS065612N	FS109477X	FS109477XNB	12V	--
FS065613N	--	FS109478XNB	24V	--
--	--	FS5000709XNB	12V	Drop-in



New	Reman	Notes
FS065624N	FS109493X	AD-IP Desiccant Cartridge



New	Reman	Notes
FS800404N	FS800404X	AD-IP / AD-IS Purge Valve
FSK022105N	--	Replaces: Bendix K022105
	NOT for use with AD-IS® / AD-IP® EverFlow® Air Dryer Modules, or AD-IP® Drop-In Air Dryer	

Section 3 Dessiccateurs d'air
 Air Dryers

Dessiccateur d'air
Air Dryer

AD-IP

New	Notes
FS5003547N	AD-IP Purge Valve Maintenance Kit

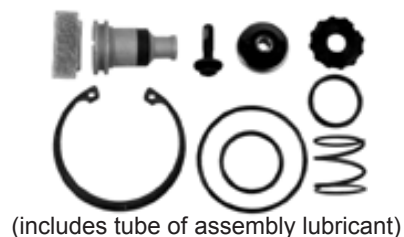

New	Electrical Specs	Plug Colour	Notes
FS109495N	12 Volts	White	Heater & Thermo Kits
FS109496N	24 Volts	Grey	

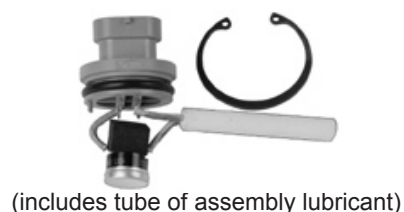

New	Notes
FS109869N	Heater Power Harness
Replaces: Bendix 109869, Wabco SRWABC002	



New	Notes
FS109494N	Check Valve Kit



New	Notes
FS5001247N	Mounting Bracket Kit

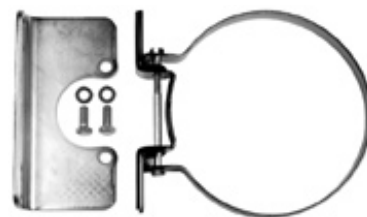

New	Notes
FS109498N	Cartridge Bolt Kit

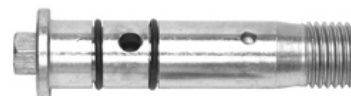

New	Notes
FS800350N	Safety Valve (150 PSI) Replaces: Bendix 109492



Propriété exclusive de FleetSpec. Toute reproduction interdite. / Exclusive property of FleetSpec. Reproduction prohibited.

Section 3 .Dessicateurs d'air · Air Dryers

AD-IS

Dessicateur d'air Air Dryer



FS5010133X
shown here



(includes tube of assembly lubricant)

Complete Air Dryer (Reman only)	Heater Voltage	Heater & Thermostat Kit	Notes
FS5004050X	12V	FS109495N (White)	Used with DRM (No Accessory Ports)
FS5010133X	12V	FS109495N (White)	"Generic", with 4 Accessory Ports
FS5010211X	24V	FS109496N (Grey)	"Generic", with 4 Accessory Ports
FS5010696X	12V	FS109495N (White)	Peterbilt & Kenworth, with 3 Accessory Ports
FS5011075X	12V	FS109495N (White)	Used with DRM (No Accessory Ports)



New	Reman	Notes
R950011N	--	Desiccant Cartridge
Replaces: Bendix 109994, 5008414, 5008415		



Double O-Rings

FSK022105N



Single O-Ring

FS800404X

New	Reman	Notes
FS800404N	FS800404X	AD-IP / AD-IS Purge Valve
FSK022105N	--	Replaces: Bendix K022105
NOT for use with AD-IS® / AD-IP® EverFlow® Air Dryer Modules, or AD-IP® Drop-In Air Dryer		



New	Notes
FS5004049N	Governor / Delivery Check Valve Kit. * Governor preset to 130 PSI. * Check Valve Maintenance Kit. * Breather included.



New	Notes
FS800350N	Safety Valve (150 PSI)

Propriété exclusive de FleetSpec. Toute reproduction interdite. / Exclusive property of FleetSpec. Reproduction prohibited.

Section 3 Dessiccateurs d'air
 Air Dryers

Dessiccateur d'air
 Air Dryer

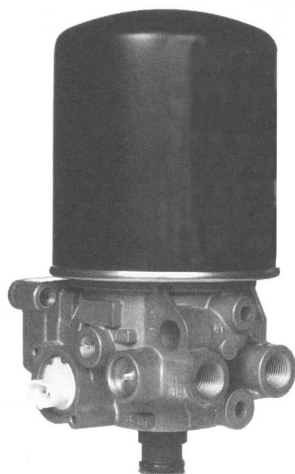

AD-SP



Complete Air Dryer	Heater Voltage	Heater & Thermostat Kit	Cartridge
FS109991X (Reman)	12V	FS109495N (White)	R950011N (New) Replaces: Bendix 109994, 5008414, and 5008415
FS109992X (Reman)	24V	FS109496N (Grey)	

New	Electrical Specs	Plug Colour	Notes
FS109495N	12 Volts	White	Heater & Thermo Kits
FS109496N	24 Volts	Grey	



(includes tube of assembly lubricant)

New	Notes
FS109869N	Heater Power Harness
Replaces: Bendix 109869, Wabco SRWABC002	



Section 3 .Dessicateurs d'air · Air Dryers

AD-2

Dessicateur d'air Air Dryer



FS286961X
shown here



Complete Air Dryer	Supply & Delivery	Heater	Cover	Cartridge
FS286934X	0.50" PT	12V, 60W	FS286875X	New: FS101900N Reman: FS101900X
FS286936X	0.50" PT	24V, 60W	FS286876X	
FS286961X	1" PT	24V, 120W	FS103253X	
FS288719X	1" PT	24V, 60W	FS286876X	

** AD-2 Air Dryers and Covers are available Reman only.



New	Reman	Notes
--	FS286873X	AD-2 Purge Valve



(includes tube of assembly lubricant)

New	Reman	Notes
FS287053N	--	AD-2 Purge Valve Kit



New	Reman	Notes
FS102657N	--	Thermostat Kit, for 12 or 24 Volt systems

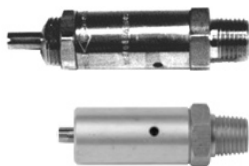

New	Reman	Notes
FS205105N	--	Safety Valve, PSI Adjustable
FS284142N	--	Safety Valve, 150 PSI

Section 3 .Dessicateurs d'air ·Air Dryers

Dessicateur d'air Air Dryer

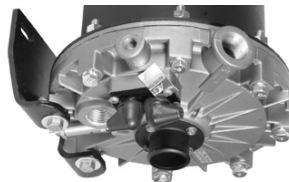

FS065089X Dryer and
 FS065090X Cover,
 with Double Terminals

AD-4



Complete Air Dryer Reman, with bracket	Complete Air Dryer Reman, NO bracket	Supply & Delivery	Heater	Cartridge Reman
FS065040X	FS065040XNB	0.75" PT	24V, 120W	FS104358X
FS065041X	FS065041XNB	0.50" PT	12V, 60W	
FS065089X	FS065089XNB	0.75" PT	24V, 120W dbl terminal	

New	Reman	Notes
FS205105N	--	Safety Valve, PSI Adjustable
FS284142N	--	Safety Valve, 150 PSI



New	Reman	Notes
FS102657N	--	Thermostat Kit, for 12 or 24 Volt systems



New	Reman	Notes
FS103818N	--	AD-4 Purge Valve Kit



New	Reman	Notes
--	FS065043X	AD-4 Cover, 24 Volts 120W
--	FS065044X	AD-4 Cover, 12 Volts 60W
--	FS065090X	AD-4 Cover, 24 Volts 120W, with Double Terminals



New	Reman	Notes
FS103980N	--	AD-4 End Cover Kit



New	Notes
FS107695N	Mounting Bracket Kit, AD-4 & AD-9



Section 3 .Dessicateurs d'air .Air Dryers

AD-9

**Dessicateur d'air
Air Dryer**

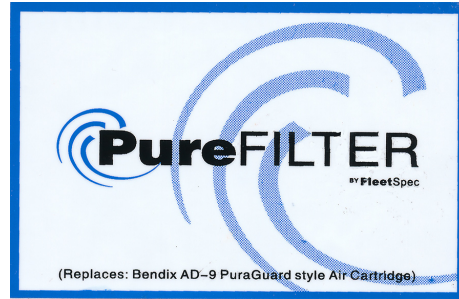

Complete Air Dryer New	Complete Air Dryer Reman, with bracket	Complete Air Dryer Reman, NO bracket	Supply & Delivery ports	Heater Specs	Notes
FS065225NPF with Bracket & Pigtail	—	FS109685XPF	0.50" PT	12V, 75W	With "Pure Filter" Cartridge
Replaces : Bendix AD-9 Puraguard 5009378PG (new) and 109685PG (reman)					

**Cartouche pour dessicateur d'air
Air Dryer Cartridge**



New	Reman	Notes
FS107794NPF	FS107794XPF	AD-9 Desiccant Cartridge, "Pure Filter" design
Replaces: Bendix 107796PG (new) and 107794PG (reman)		

Section 3 .Dessicateurs d'air
 ·Air Dryers

Dessicateur d'air
Air Dryer

AD-9

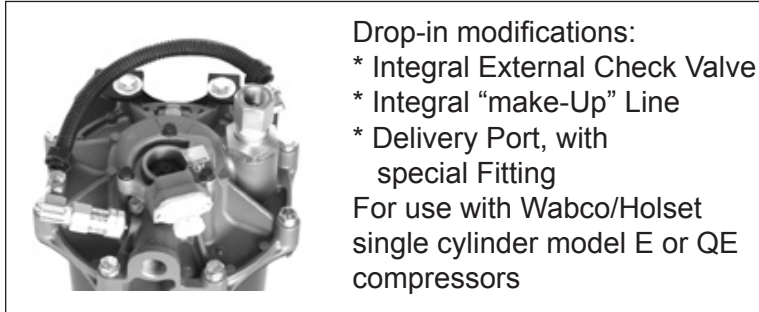

Complete Air Dryer New	Complete Air Dryer Reman, with bracket	Complete Air Dryer Reman, NO bracket	Supply & Delivery ports	Heater Specs	Notes
FS065224N	FS065224X	FS065224XNB	0.75" PT	24V, 75W	Most 24V, including buses
FS065224NNB					
--	--	FS065224AXNB	0.75" PT	24V, 75W	New style with Horizontal Check Valve
FS065224N100W	--	FS065224XNB100W	0.75" PT	24V 100W	24V Bus & Off-Road
FS065224NNB100W					
--	--	FS065228XNB	0.75" PT	12V, 75W	With Extended Purge
--	--	FS065243XNB	0.50" PT	12V, 75W	With Extended Purge
--	FS065499X	FS065499XNB	0.50" PT	12V, 75W	With DLU Purge Valve
--	--	FS065647XNB	0.50" PT	12V, 75W	AD-9 DI (Drop-In)
FS065225N	FS109685X	FS109685XNB	0.50" PT	12V, 75W	Truck & Tractor apps.
FS065225NNB					
--	--	FS109685AXNB	0.50" PT	12V, 75W	New style with Horizontal Check Valve
--	--	FS109687XNB	0.75" PT	12V, 75W	Truck & Tractor apps.
--	--	FS109688XNB	0.75" PT	24V, 75W	With Extended Purge

Section 3 .Dessicateurs d'air .Air Dryers

AD-9

Dessicateur d'air Air Dryer



New	Reman	Notes
FS107794N	FS107794X	AD-9 Desiccant Cartridge
Replaces: Bendix 107796		



New	Reman	Supply & Delivery	Heater specs
FS065229N	FS065229X	.75" PT	24 Volts, 75 Watts, Grey
--	FS065230X	.75" PT	12 Volts, 75 Watts, White
FS065231N	FS065231X	.50" PT	12 Volts, 75 Watts, White



New	Reman	Heater	Notes
FS800405N	FS5004341X	12V, 75W	Purge Valves (Soft Seat)
FS5004338N	FS5004342X	24V, 75W	
FS5004381N	--	24V, 100W	Purge Valves (Hard Seat)
FS5004479N	--	12V, 75W	
FS5004480N	--	24V, 75W	
FS112399N	AD-9 Exhaust Cover <only>		



FS112399N

Section 3 .Dessicateurs d'air
 .Air Dryers

Dessicateur d'air
Air Dryer

AD-9

New	Electrical Specs	Plug Colour	Notes
FS109578N	12V, 75W	White	Heater & Thermo Kits
FS109579N	24V, 75W	Grey	
FS5002595N	24V, 100W	Yellow	



(includes tube of assembly lubricant)

New	Notes
FS5005037N	Purge Valve kit, Hard Seat
FS5005893N	Purge Valve kit, Soft Seat



New	Notes
FS109869N	Heater Power Harness
Replaces: Bendix 109869, Wabco SRWABC002	



New	Size	Notes
FS107799N	0.75" PT	Check Valve
FS107800N	0.50" PT	



New	Notes
FSK041395N	Check Valve Kit, for AD-9 New style Horizontal Cover

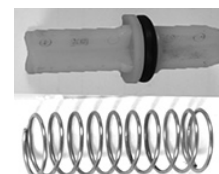

New	Notes
FS800350N	Safety Valve (150 PSI)



New	Notes
FS107695N	Mounting Bracket Kit, AD-4 & AD-9



Section 3 .Dessicateurs d'air · Air Dryers

Dessicateur d'air Air Dryer



R955205N shown here



R955300X shown here



Complete Air Dryer		Voltage	Replaces	Cartridge
New	Reman			
R955205N	R955205X	12V	432 413 001 0 432 413 003 0	R950011N (New)
R955206N	R955206X	24V	432 413 002 0 432 413 004 0	
—	R955300X	12V	432 421 009 0 (Volvo VN applications)	



New	Notes
R950014	Purge Valve Kit



New	Notes
S4341003100	Pressure Controlled Check Valve

Section 3 Dessicateurs d'air
 Air Dryers

Dessicateur d'air
Air Dryer

New	Voltage	Notes
R950015	12V	Heater Repair Kit, Date Code 0994 and Later
R950016	24V	Heater repair Kit, All models



New	Notes
R950044	Regeneration Valve Kit ** Date code 2295 and later



New	Notes
R950045	Regeneration Valve Diaphragm <only>

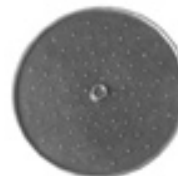

New	Notes
R950013	Turbo Cut-off Valve Kit



New	Notes
R950017	Outlet Check Valve Kit



New	Notes
FS109869N	Heater Power Harness
Replaces: Bendix 109869, Wabco SRWABC002	



New	Notes
FS-11034	Safety Valve, 3/8" PT (150 PSI)
Replaces: Wabco S2206-D-1226	



Compatible avec
Compatible with

Haldex/Midland

"Votre source pour tous vos pièces neuves et remanufacturées depuis 1996"
"Your trusted source for quality New & Reman air components since 1996"

Section 3 .Dessicateurs d'air ·Air Dryers

Dessicateur d'air et Postrefroidisseur Air Dryer & Aftercooler

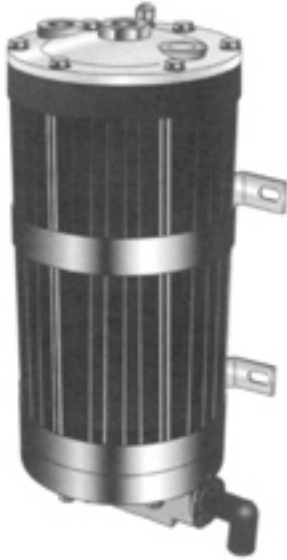

New	Reman	Notes
--	FSKN33000X	"Pure Air" Dryer, 12Volt
--	FSKN33050X	"Tornado" Aftercooler, 12 Volt

May be mounted vertically or horizontally.
Serviceable from either end.

Compatible avec
Compatible with

CR / SKF

"Votre source pour tous vos pièces neuves et remanufacturées depuis 1996"
"Your trusted source for quality New & Reman air components since 1996"

Postrefroidisseur Aftercooler



New	Reman	Notes
--	FS7101X	Model 62, 18-1/2" tall
--	FS7103X	Model 68, 23-1/2" tall

Section 3 .Dessicateurs d'air ·Air Dryers

Evaporateur d'alcool Alcohol Evaporator

New	Reman	Notes
FS-5210	--	Alcohol Evaporator Replaces: Midland A72420

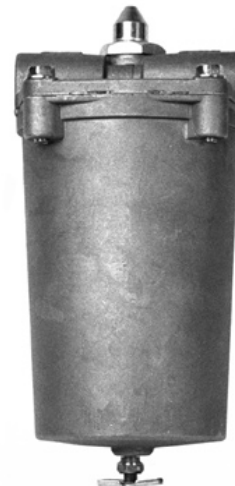

New	Reman	Notes
FS-5210SV	--	Replacement Safety Valve <only> ** Caution ** will NOT replace Midland A75420 on Haldex A72420 OEM Evaporator



New	Reman	Notes
FS-5210K	--	Rebuild Kit

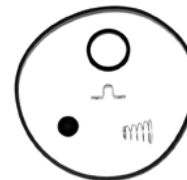

Section 3 .Dessiccateurs d'air
·Air Dryers

Dessiccateur d'air Turbo-2000
Turbo-2000 Air Dryer



New	Reman	Notes
–	FS-T620602X	Turbo-2000 Dryer, 12 Volt
–	FS-T620606X	Turbo-2000 Dryer, 24 Volt



New	Reman	Notes
FS-T221	–	Turbo-2000, HD-2000 Purge Tank Kit (460 cu.in.)

Cartouche pour dessiccateur d'air
Air Dryer Cartridge

FS-T224

FS-T224A



New	Reman	Application
FS-T224	–	CR Brakemaster Turbo-2000, for Original Design Dryers
FS-T224A	–	CR Brakemaster Turbo-2000, for Revised Design Dryers. * Also fits Original Design.

Heater & Thermo Kits



New	Electrical Specs	Plug Colour
FS-T619110	12 Volts, 75 Watts	White
FS-T619111	24 Volts, 75 Watts	Grey



Section 4

Soupapes - freins à air
Air Brake System Valves

Section 4 . Soupapes - freins à air
 . Air Brake System Valves

Soupapes de dosage pour freins à air
Air Brake Proportioning Valves

New	Reman	Application	Nominal Holdoff	Nominal Equalizing
--	FS104598X	Front	4 PSI	50 PSI
--	FS106284X	Rear	8 PSI	105 PSI

The front and rear applications of the BP-1 are **not** interchangeable

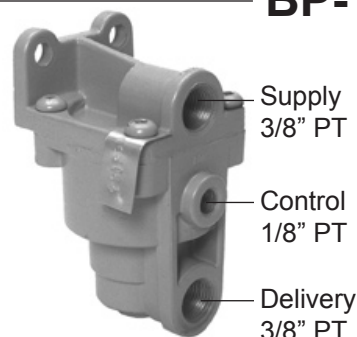

Soupapes de dosage pour tracteur haut-le-pied
Bobtail Proportioning Relay Valves

New	Reman	Crack PSI
FS065145N	--	4
FS065146N	--	5.5

(Mounting Bracket included)

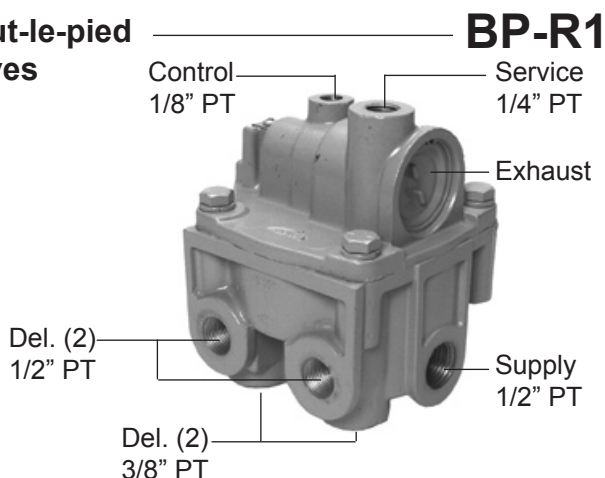

Clapets double
Double Check Valves

New	Reman	Ports (3)
FS278614N	--	3/8" PT
FS278615N	--	1/4" PT

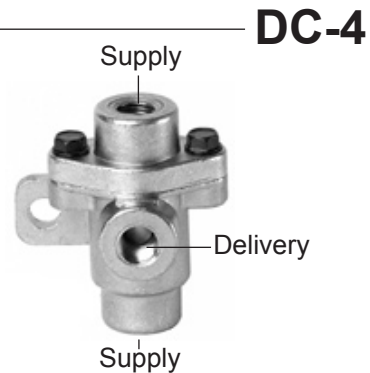

New	Reman	Del.(2)	Supply	Supply Nipple
--	FS278595X	1/4" PT	1/4" PT	1/2" PT
--	FS278596X	3/8" PT	1/4" PT	1/2" PT
--	FS278597X	1/4" PT	1/4" PT	3/8" PT
--	FS278598X	3/8" PT	1/4" PT	3/8" PT
--	FS5019291X	3/8" PT	1/4" PT	3/8" PT

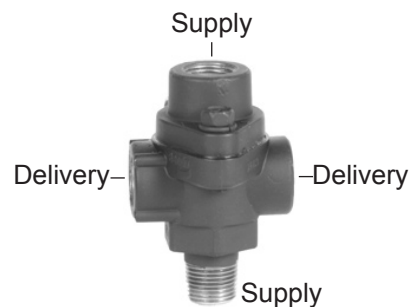

Propriété exclusive de FleetSpec. Toute reproduction interdite. / Exclusive property of FleetSpec. Reproduction prohibited.

Section 4 . Soupapes - freins à air . Air Brake System Valves

D-2

Gouverneur
Governor



New	Reman	Notes
FS284358N	--	High temperature and waterproof. Comes with Mounting Gasket & 4 Plugs Operating pressures: Cut-In: 105 PSI Cut-Out: 125 PSI
FS236577N	Mounting Gasket <only> Replaces: Bendix 5007834	

DV-2

Valves de purge automatique, *sans* réchauffeur électrique
Automatic Drain Valves, *without* heating element

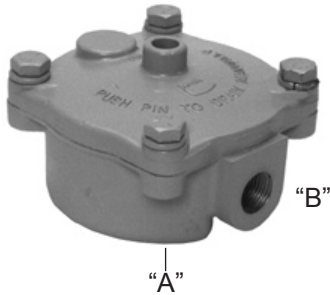

New	Reman	Heater	Mount
FS281923N	--	--	"A"
FS281924N	--	--	"B"
Note: All ports (2) are 3/8"			

DV-2

Valves de purge automatique, *avec* réchauffeur électrique
Automatic Drain Valves, *with* heating element

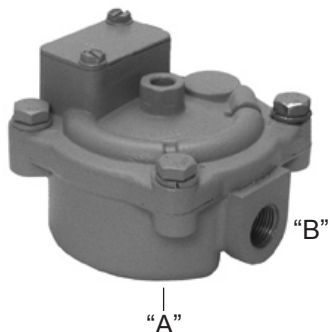

New	Reman	Heater	Mount
FS284412N	--	12V	"A"
FS284795N	--	12V	"B"
--	FS284818X	24V	"A"
Note: All ports (2) are 3/8"			

Section 4 .Souppapes - freins à air
 ·Air Brake System Valves

Clapets de pied à circuit unique
Single Circuit Foot Valves

E-3

New	Reman	Notes
FS277863N	FS277863X	Aux Del. Port blocked
—	FS278998X	With Aux Del. Port

Treadle and mounting brackets **not** included

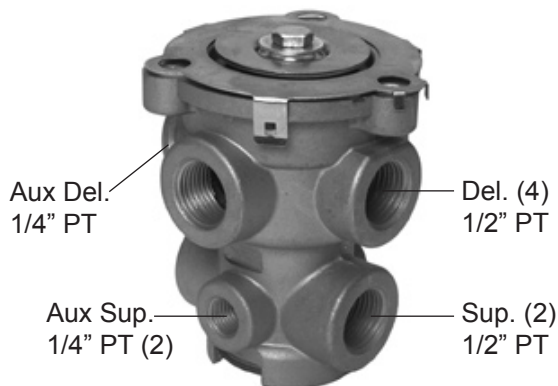

Clapet de pied à double circuit
Dual Circuit Foot Valve

E-4

New	Reman
—	FS279750X

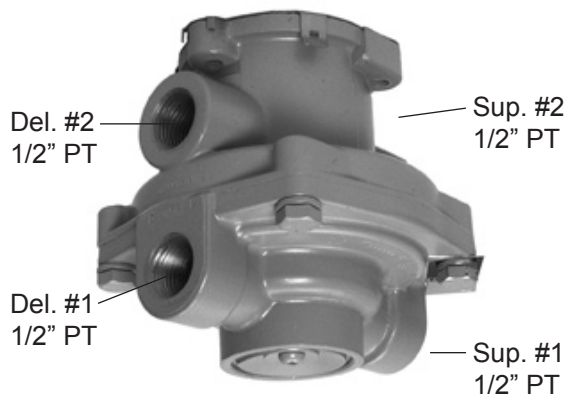

Treadle and mounting brackets **not** included

Clapet de pied à circuit unique
Single Circuit Foot Valve

E-5

New	Reman	Del. Ports	Sup. Ports
—	FS279950X	D1: 1/4" PT (2) D2: 3/8" PT (1) D3: 1/2" PT (1)	S1: 1/4" PT (6) S2: 1/2" PT (1) S3: 1/8" PT (1)

Treadle and mounting brackets **not** included

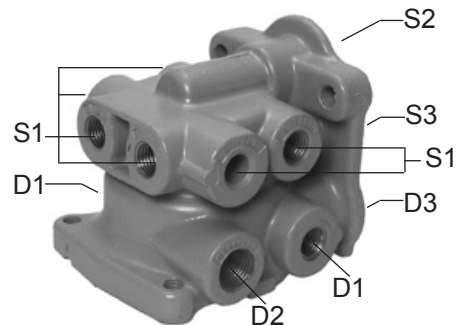

Section 4 . Soupapes - freins à air . Air Brake System Valves

E-6

Clapets de pied à double circuit Dual Circuit Foot Valves

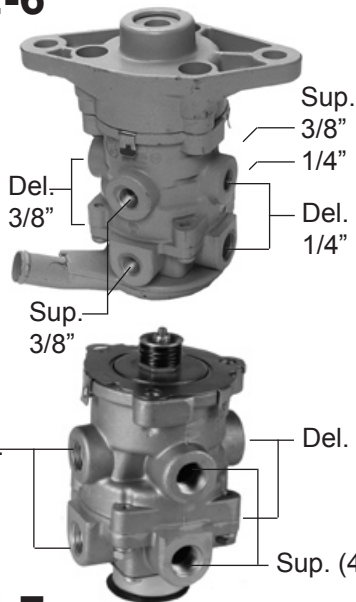

New	Reman	Notes
—	FS104308X	Ford Flange Mount

Treadle and mounting brackets **not** included



New	Reman	Notes
FS286171N	—	All ports (8) are 3/8"

Treadle and mounting brackets **not** included

E-7

Clapets de pied à double circuit Dual Circuit Foot Valves

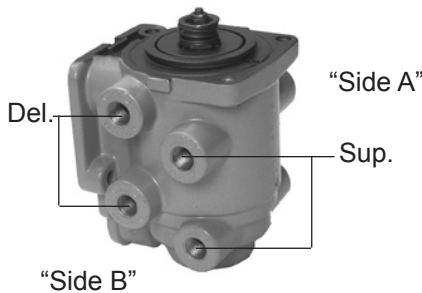

New	Reman	Side A Del.	Side A Sup.	Side B Del.	Side B Sup.	Exhaust
—	FS101818X	3/8" (2)	1/4" (2)	3/8" (2)	1/4" (2)	Diaphragm
—	FS284760X	—	—	—	1/4" (2)	Diaphragm
—	FS286774X	1/4" (2)	1/4" (2)	1/4" (2)	1/4" (2)	1/2" PT
—	FS287411X	3/8" (2)	3/8" (2)	1/4" (2)	1/4" (2)	1/2" PT
—	FS288267X	3/8" (2)	3/8" (2)	1/4" (2)	1/4" (2)	Diaphragm
—	FS288383X	1/4" (2)	1/4" (2)	1/4" (2)	1/4" (2)	Diaphragm

Treadle and mounting brackets **not** included

E-8P

Clapets de pied à double circuit Dual Circuit Foot Valves

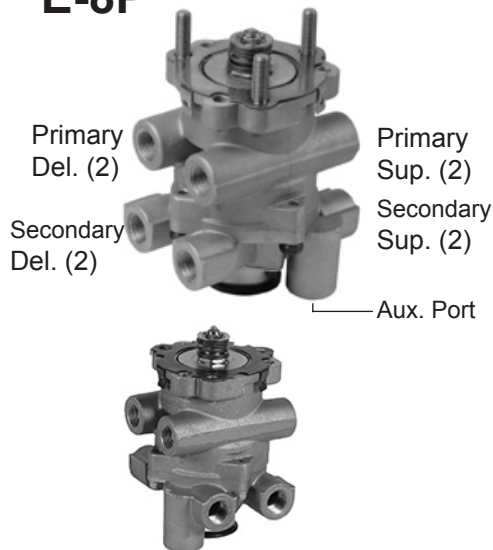

New	Reman	Notes
FS800629N	FS800629X	All ports (9) are 3/8" PT

Treadle and mounting brackets **not** included

New	Reman	Notes
FS800630N	FS800630X	All ports (8) are 3/8" PT
For Volvo applications		

Section 4 . Soupapes - freins à air
 Air Brake System Valves

Clapet de pied à double circuit
Dual Circuit Foot Valve

E-10

New	Reman	Notes
--	FS101100X	All ports (8) are 3/8"

Treadle and mounting brackets **not** included

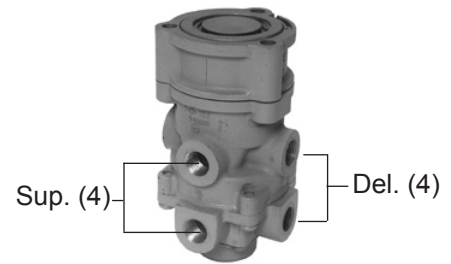

Clapet de pied à double circuit
Dual Circuit Foot Valve

E-10P

New	Reman	Notes
--	FS800632X	All ports (8) are 3/8"
Replaces: E-15 # 065315, 800318		

Treadle and mounting brackets **not** included

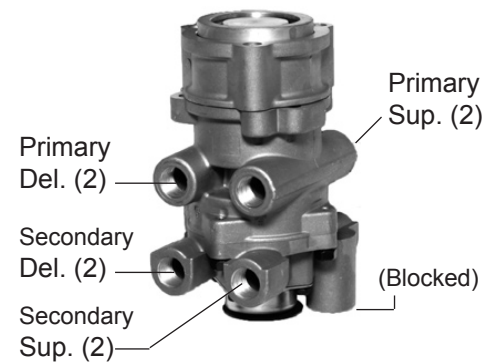

Clapet de pied à double circuit
Dual Circuit Foot Valve

E-12

New	Reman	Notes
--	FS065313X	All ports (8) are 3/8"
** Can be replaced with E-8P (FS800629N)		

Treadle and mounting brackets **not** included

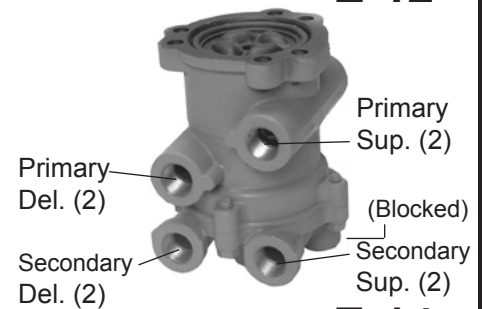

Clapet de pied à double circuit
Dual Circuit Foot Valve

E-14

New	Reman	Notes
--	FS065395X	Used with a Manifold. Non-manifold ports (8) are 3/8" Exhaust is by a diaphragm.

Treadle and mounting brackets **not** included

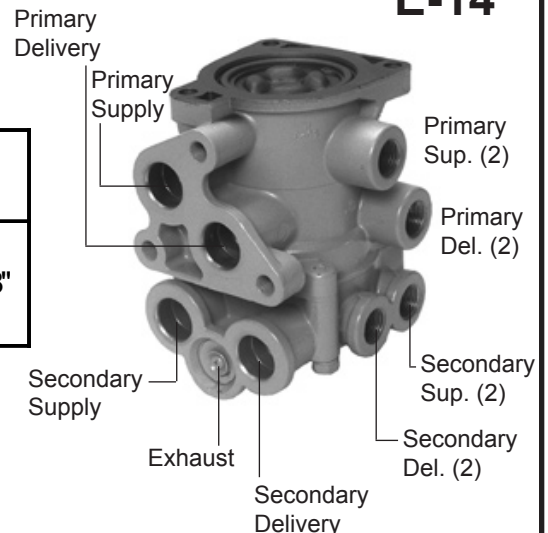

Section 4 • Soupapes - freins à air • Air Brake System Valves

LP-3

Manocontacteurs de basse pression Low Pressure Switches



FS228750N
shown here

New	Reman	Terminals	Notes
FS228750N	--	Dual	Contacts Closed below 60 PSI (± 6 PSI)
FS279416N	--	Single	

LQ-2

Échappements rapide & limiteurs Limiting and Quick Release Valves

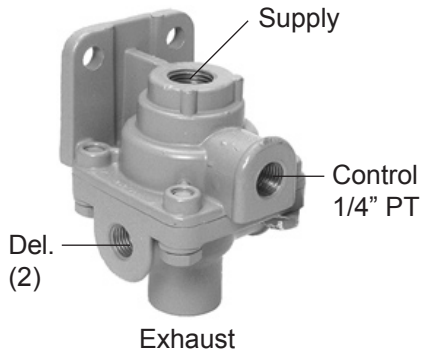

New	Reman	Sup. (PT)	Del. (PT)
FS229505N	--	3/8"	3/8"
FS229507N	--	1/2"	1/4"
FS229509N	--	3/8"	1/4"

LQ-4

Soupape de rapport pour essieu avant Front Axle Ratio Valve

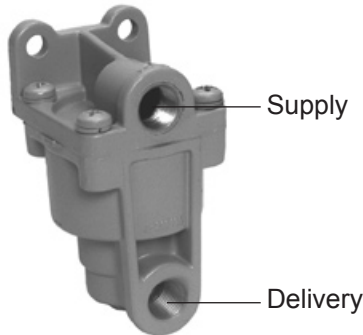

New	Reman	Sup. (PT)	Del. (PT)
FS289144N	FS289144X	3/8"	3/8"
Nominal Hold-off: 4 PSI. Nominal Equalizing: 60 PSI.			

LQ-5

Soupape de rapport pour tracteur haut-le-pied Bobtail Ratio Valve

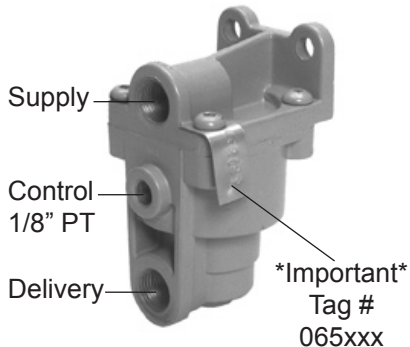

New	Reman	Sup. (PT)	Del. (PT)
--	FS065154X	3/8"	3/8"
* IMPORTANT * Do not replace this LQ-5 with a Front or Rear BP-1			

Section 4 . Soupapes - freins à air
 · Air Brake System Valves

Module de commande
Control Module

MV-2

New	Reman	Notes
–	FS101437X	Complete Module All ports (6) are 1/4"
–	FS101569X	Spool Assembly <only> "A" Red
–	FS101570X	Spool Assembly <only> "B" Yellow



"A"



"B"

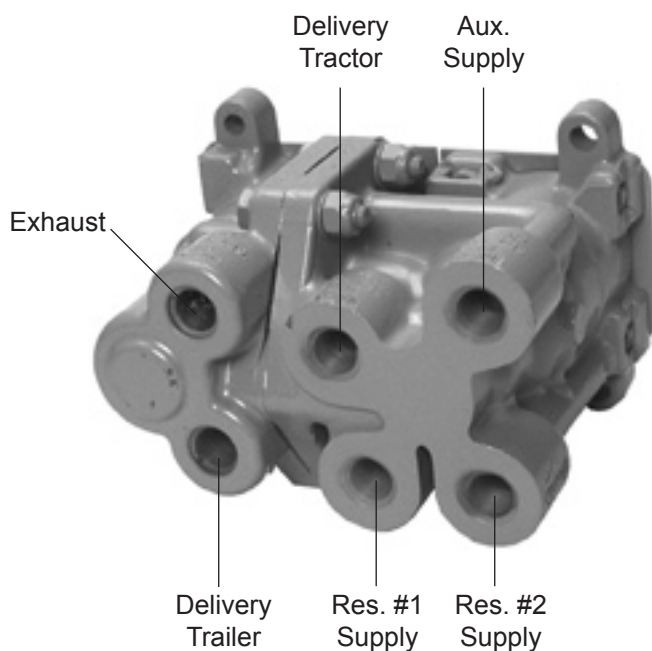

Section 4 . Soupapes - freins à air . Air Brake System Valves

MV-3

Modules de commande Control Modules

FS800515N
shown here



FS298817N
Red knob <only>



FS298818N
Yellow knob <only>

"New" Style, with 1/4" PT or P-T-C

"Old" Style, with Exhaust Nipple

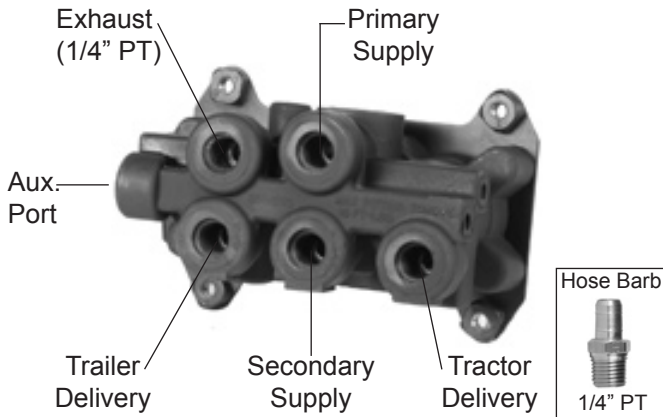

Fig. 1

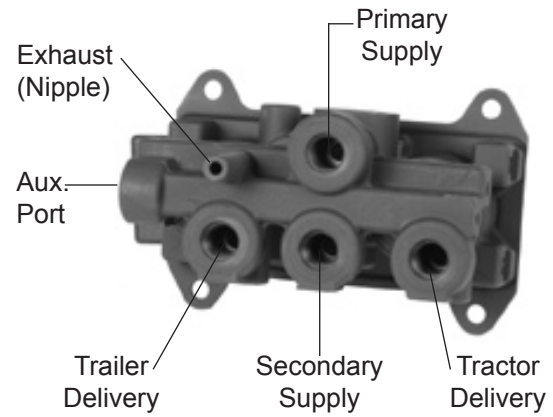

Fig. 3

Fig. 4

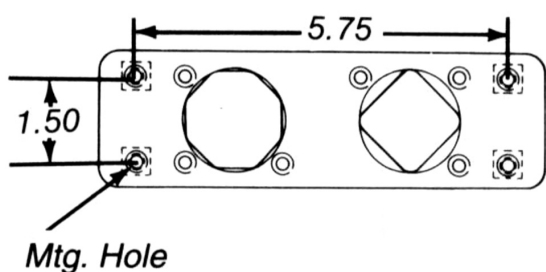
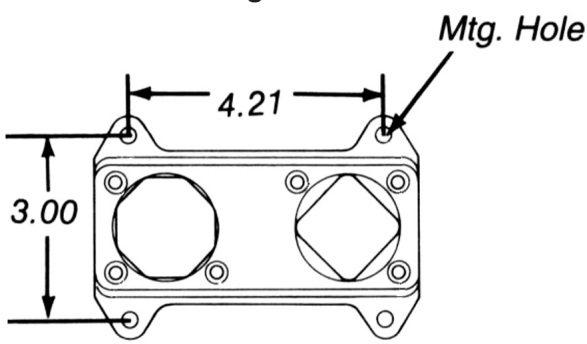
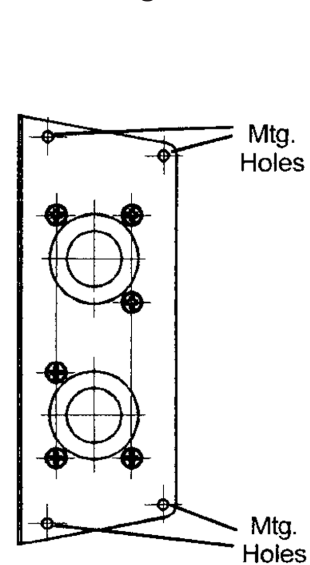
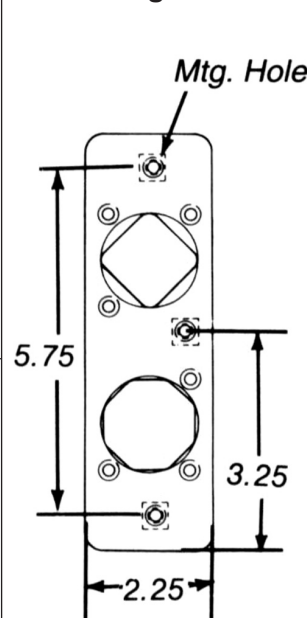

Fig. 2



FleetSpec

Section 4 . Soupapes - freins à air
 · Air Brake System Valves

Modules de commande
Control Modules

MV-3

New **	Reman *	Fig	Mtg. Hole	Aux. port	Exh. port	Del. Ports
FS800515N	FS065156X	1	M6 x 1-6H	None	Nipple	1/4" PT
FS800516N	FS065157X	1	.27" Dia.	None	Nipple	1/4" PT
FS800573N	FS065186X	1	1/4"-20 THD	None	Nipple	1/4" PT
--	FS065208X	1	M6 x 1-6H	1/8" PT	Nipple	1/4" PT
FS800523N	FS065248X	1	#10-24	None	Nipple	1/4" PT
--	FS065523X	1	.27" Dia.	None	Nipple	Push-to-Connect
FS800257N	FS800257X	1	.27" Dia.	None	Push-to-Connect	Push-to-Connect
--	FS800258X	3	M6 x 1-6H	None	Push-to-Connect	Push-to-Connect
FS800259N	FS800259X	1	1/4"-20 THD.	None	Push-to-Connect	Push-to-Connect
FS800260N	FS800260X	1	M5 x 8.0 -6H	None	Push-to-Connect	Push-to-Connect
--	FS800353X	1	#10-24	None	Push-to-Connect	Push-to-Connect
FS800515N	FS800515X	1	M6 x 1-6H	None	1/4" PT ***	1/4" PT
FS800516N	FS800516X	1	.27" Dia.	None	1/4" PT ***	1/4" PT
FS800517N	FS800517X	2	M6 x 1-6H	None	1/4" PT ***	1/4" PT
--	FS800518X	1	.27" Dia.	1/8" PT	1/4" PT ***	1/4" PT
FS800519N	FS800519X	1	1/4"-20 THD.	None	1/4" PT ***	1/4" PT
FS800521N	FS800521X	3	1/4"-20 THD.	None	1/4" PT ***	1/4" PT
--	FS800522X	1	M6 x 1-6H	1/8" PT	1/4" PT ***	1/4" PT
FS800523N	FS800523X	1	#10-24	None	1/4" PT ***	1/4" PT
--	FS800529X	4	.20 Dia.	None	Nipple	Push-to-Connect
FS800573N	FS800573X	1	1/4"-20 THD.	None	1/4" PT ***	1/4" PT
FS800622N	FS800622X	2	M6 x 1-6H	None	Push-to-Connect	Push-to-Connect
--	FS801631X	4	.20 Dia.	None	P-T-C 90°	P-T-C 90°

* Reman Valves do NOT include buttons.
 ** Buttons ARE included with New Valves.
 *** Hose Barb Fitting included.

Section 4 . Soupapes - freins à air . Air Brake System Valves

PP-1

Commandes à double effet Push & Pull Controls

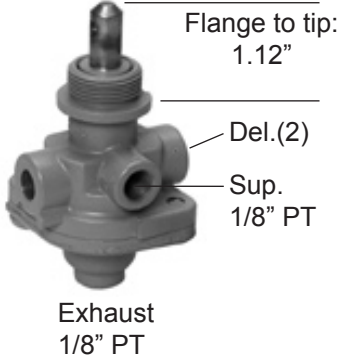

New	Reman	Del.	Release	Shaft
FS276566N	--	1/8"	20 PSI	3/8"
FS276567N	--	1/8"	40 PSI	3/8"
--	**FS280995X	1/8"	40 PSI	3/8"
--	FS281587X	1/8"	40 PSI	1/2", 1/4-20 Thd.
--	**FS282499X	1/4"	40 PSI	3/8"
--	FS287417X	1/4"	30 PSI	3/8"
--	FS287600X	1/4"	40 PSI	3/8"
--	FS287637X	1/8"	Non-Auto	1/4"

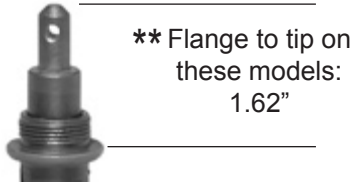

PP-2

Commandes à double effet Push & Pull Controls

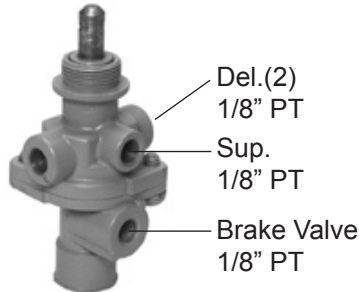

New	Reman	Release	Shaft
--	FS276462X	40 PSI	3/8"
--	FS280454X	40 PSI	1/4-20 thd.

PP-3

Commandes à double effet avec déclencheur automatique Push & Pull Controls with Automatic Tripper

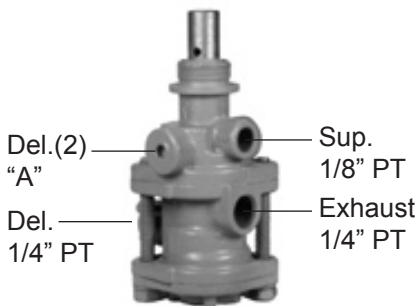

New	Reman	Del. "A"	Shaft
--	FS279787X	Plugged	1/4-20 thd
--	FS288746X	Plugged	3/8"
--	FS289477X	1/8" PT	3/8"
--	FS289512X	1/8" PT	1/4-20 thd

Section 4 . Soupapes - freins à air
 · Air Brake System Valves

Soupapes d'alimentation pour remorque
Trailer Supply Valves

PP-7

New	Reman	Shaft	Notes
-	FS101479X	3/8"	Index notch in Panel Flange
FS288239N	-	3/8"	
-	FS288240X	1/2", 1/4-20 thd.	
-	FS288241X	5/16"	Exhaust port has 1/4" PT
-	FS288242X	1/2", 1/4-20 thd.	
* All release at 40 PSI			

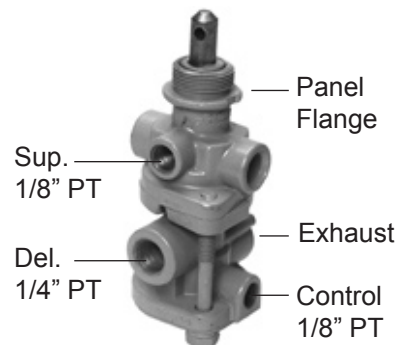

Robinets de réglage manuel
Manually Operated Control Valves

PP-8

New	Reman	Del.	Shaft
-	FS287238X	1/8"	1/2"
-	FS287418X	1/4"	1/2"

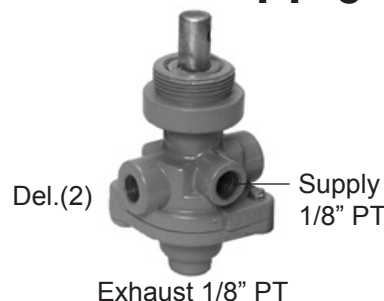

Boutons de soupape à poussoir
Buttons for Push & Pull Control Valves

New	Shaft	Color	Text
* FS240272N	3/8"	Black	Upper: Push to charge Mid: EMERGENCY BRAKE not for parking Lower: Pull for Emergency
* FS241866N	3/8"	Black	- None -
** FS290655N	3/8"	Red	Upper: Push to charge Mid: TRAILER Air Supply Lower: Not for parking
* This button comes with a Roll Pin & Panel Mount Nut. ** This button comes with a Roll Pin <only>			

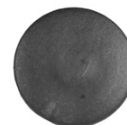

Section 4 . Soupapes - freins à air · Air Brake System Valves

PP-DC

Soupapes de commande de stationnement Park Control Valves

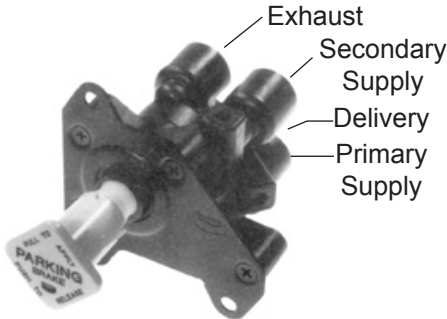

New	Reman	Mtg. Holes	Port Fittings
FS065661N	FS065661X	1/4"-20 Thd.	Push-to-Connect
--	FS800142X	1/4"-20 Thd.	1/4" PT

Button for illustrative purposes only. **Not** included with Reman valves

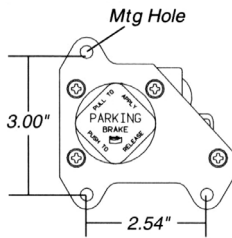

Original Part #:	Replaced by:
BW109795	FS065661_
BW109880	FS065661_
BW287597	FS800142X

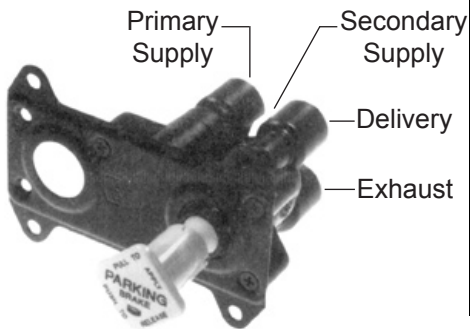

New	Reman	Mtg. Holes	Port Fittings
--	FS065643X	0.27" Dia.	Push-to-Connect
--	FS800004X	#10-24 Thd.	Push-to-Connect
FS800034N	FS800034X	0.27" Dia.	1/4" PT
--	FS801315X	0.27" Dia.	P-T-C, 90°

Button for illustrative purposes only. **Not** included with Reman valves

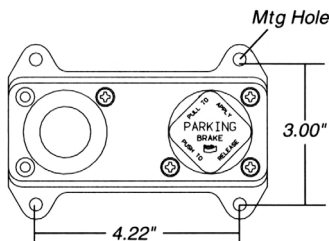

Original Part #:	Replaced by:
BW109636	FS065643X
BW5000054	FS800004X
BW5000360	FS800034_

Section 4 . Soupapes - freins à air
 Air Brake System Valves

Valves de protection
Pressure Protection Valves

PR-2

New	Reman	Nominal Closing Pressure
FS277147N	--	65 PSI
FS277227N	--	75 PSI
FS277148N	--	85 PSI
All ports (2) 1/4" PT		

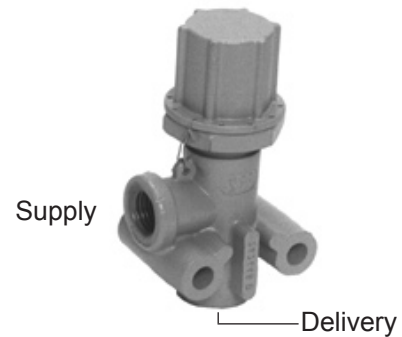

Valve de protection
Pressure Protection Valve

PR-3

New	Reman	Nominal Closing Pressure
FS286460N	--	60 PSI
All ports (2) 1/4" PT. This valve is used with "older model" SR-4 valves (FS101112X / FS101622X).		

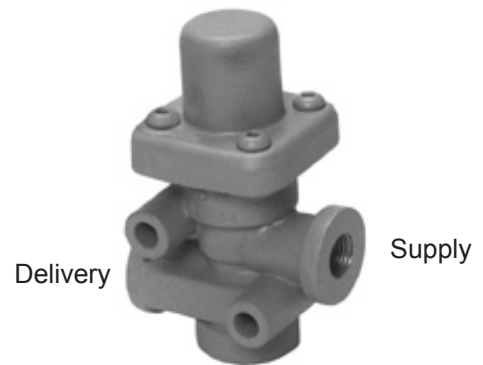

Valves de protection
Pressure Protection Valves

PR-4

New	Reman	Nominal Closing Pressure
FS286500N	--	85 PSI
FS288323N	FS288323X	70 PSI
All ports (2) 1/4" PT		

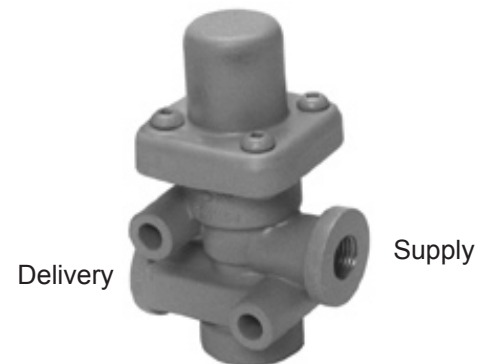

Section 4 . Soupapes - freins à air . Air Brake System Valves

QR-1

Valves de desserrage rapide Quick Release Valves

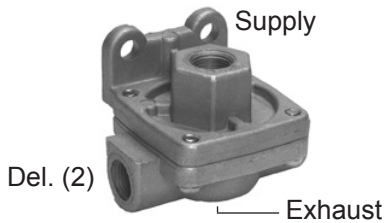

New	Reman	Sup.	Del.
FS229813N	--	3/8" PT	1/4" PT
FS229859N	--	3/8" PT	3/8" PT
FS229860N	--	1/2" PT	3/8" PT
Crack @ 0 PSI, Metallic construction.			

QR-1

Valves de desserrage rapide, en composite Quick Release Valves, corrosion resistant design

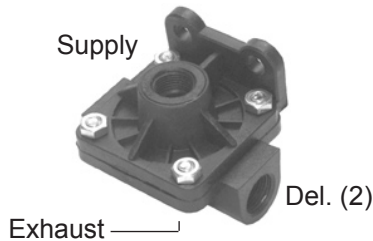

New	Reman	Sup.	Del.
FS065066N	--	1/2" PT	3/8" PT
FS065067N	--	3/8" PT	3/8" PT
Crack @ 0 PSI, Composite construction			

QR-N

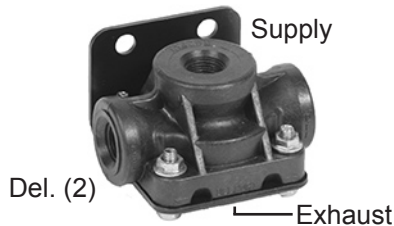

New	Reman	Sup.	Del.
FS802743N	--	3/8" PT	3/8" PT
FS802745N	--	1/2" PT	3/8" PT
Crack @ 1 PSI, Composite construction			

QR-1C

Valves de desserrage rapide de non-addition des efforts de freinage Anti-Compounding Quick Release Valves

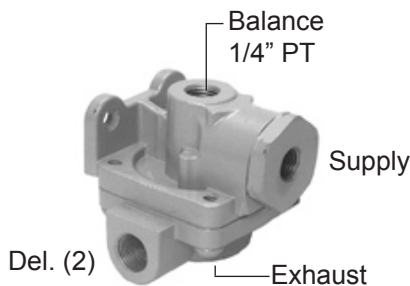

New	Reman	Sup.	Del.
--	FS289182X	1/4" PT	1/4" PT
FS289714N	--	1/4" PT	3/8" PT
Crack @ 0 PSI, Metallic construction			

QR-L

Valve de desserrage rapide de conduite In-Line Quick Release Valve

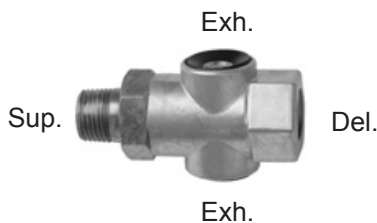

New	Reman	Male pipe stud	Female port
FS800333N	--	1/2" PT	1/2" PT
Direct Mount			

Section 4 . Soupapes - freins à air
 . Air Brake System Valves

**Valves relais
 Relay Valves**

R-6

New	Reman	Mounting Flange Spacing	Service Port * Rotation
FS279180N	--	2-1/2"	180 °
FS279952N **	FS279952X **	2-1/2"	180 °
FS283940N	FS283940X	5" (Ford)	270 °

Nominal pressure differential: 2 PSI
 ** "A" is a 3/4" PT Supply on this valve <only>

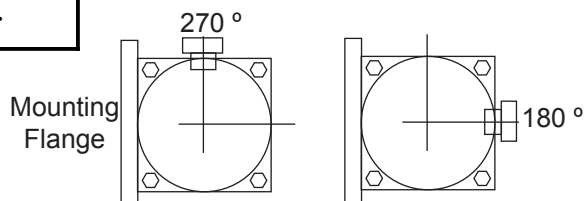
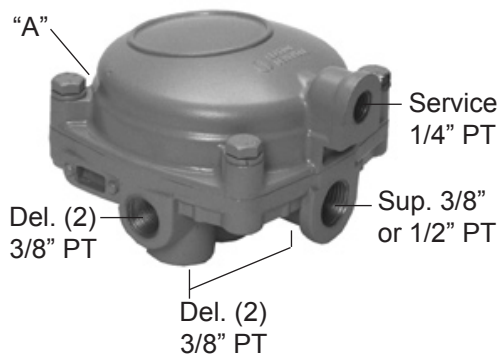

* Service Port Rotation, as seen from the top

**Valve relais
 Relay Valve**

R-7

New	Reman
FS103081N	--

Spring Brake release pressure: 95 PSI

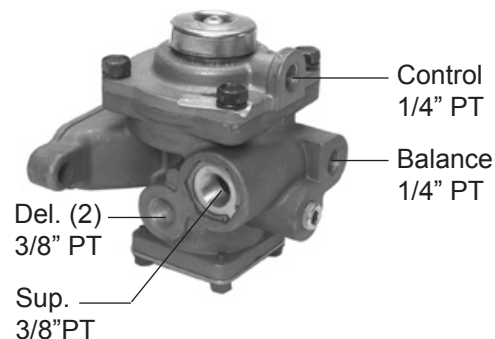

**Valves relais
 Relay Valves**

R-8

New	Reman	Service Port * Rotation	Nominal Pressuse Differential
--	FS101930X (Metric Ports)	180 °	3 PSI
FS286370N	--	90 °	3 PSI
FS288369N	--	180 °	3 PSI
--	FS288755X	180 °	5 PSI

Spring Brake release pressure: 95 PSI.
 Balance port is located under the cover.

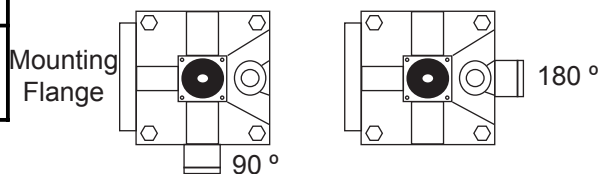
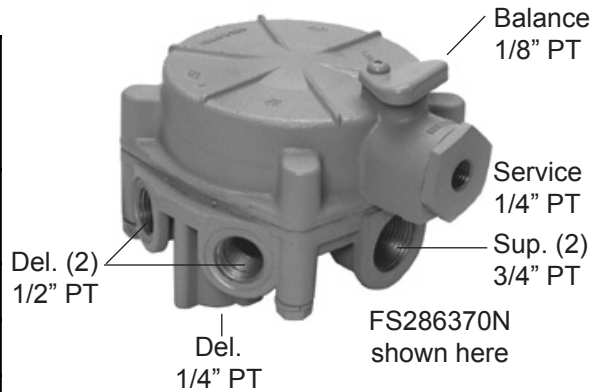

* Service Port Rotation, as seen from the bottom

Propriété exclusive de FleetSpec. Toute reproduction interdite. / Exclusive property of FleetSpec. Reproduction prohibited.

Section 4 • Soupapes - freins à air • Air Brake System Valves

R-8P

Valve relais Relay Valve

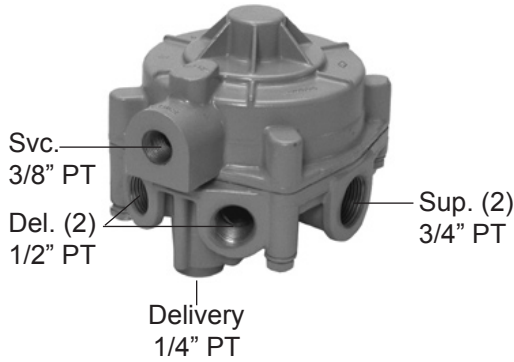

New	Reman
FS287114N	FS287114X

R-10

Valve relais Relay Valve

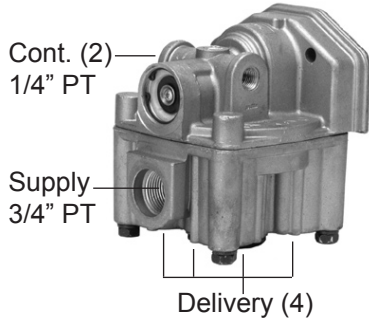

New	Reman	Del. Ports	Notes
FS101333N	–	1/2" PT	Crack @ 4.0 PSI
4 vertical Delivery Ports			

R-12

Valves relais Relay Valves

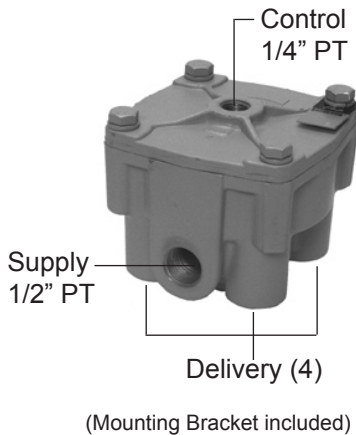

New	Reman	Del. Ports	Notes
FS065104N	–	3/8" PT	Crack @ 4.0 PSI
FS102626N	–	1/2" PT	Crack @ 4.0 PSI
–	FS104561X	3/8" PT	Crack @ 5.5 PSI
FS800365N	–	3/8" PT	DuraDrain; Crack @ 4.0 PSI
FS800636N	–	1/2" PT	DuraDrain; Crack @ 4.0 PSI
4 Vertical Delivery Ports			

Section 4 . Soupapes - freins à air
 · Air Brake System Valves

**Valves relais
 Relay Valves**

R-12

New	Reman	Del. Ports	Notes
FS065206N	FS065206X	3/8" PT	Crack @ 5.5 PSI
FS065303N	--	3/8" PT	Crack @ 4.0 PSI
4 Delivery Ports, 2 Vertical & 2 Horizontal			

(Mounting Bracket included)

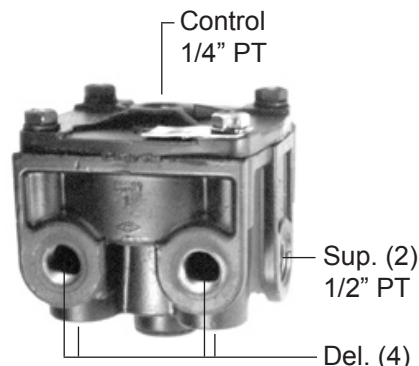

**Valves relais
 Relay Valves**

R-12DC

New	Reman	Notes
FS800470N	FS800470X	Crack @ 4.0 PSI
FS800471N	FS800471X	Crack @ 5.5 PSI
2 Horizontal Delivery Ports		

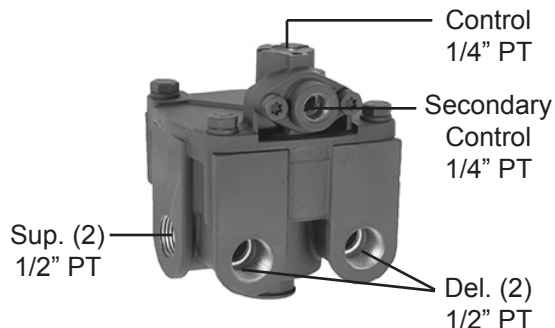

New	Reman	Notes
FS800481N	FS800481X	Crack @ 4.0 PSI
2 Horizontal, and 2 Vertical Delivery Ports		

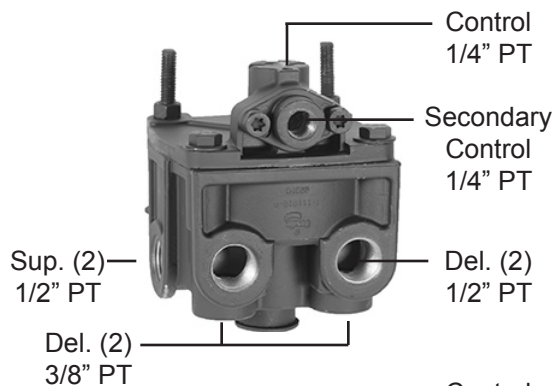

New	Reman	Notes
FS800477N	FS800477X	Crack @ 4.0 PSI
4 Vertical Delivery Ports		

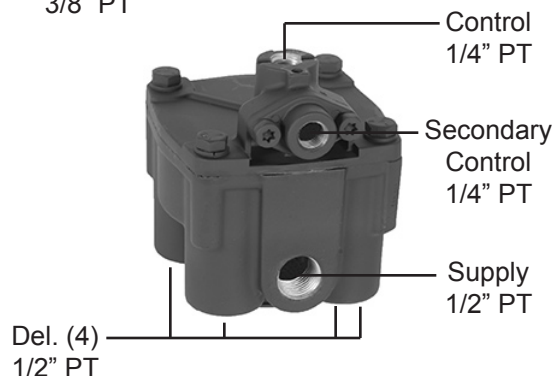

Section 4 . Soupapes - freins à air · Air Brake System Valves

R-12H

Valves relais Relay Valves

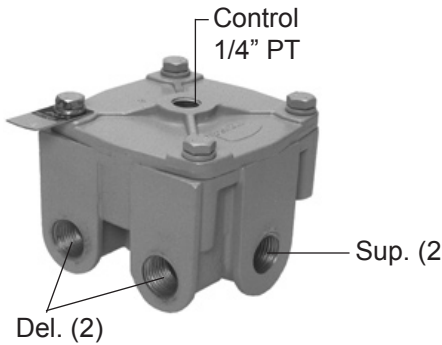

New	Reman	Sup. Ports	Notes
FS065125N	FS065125X	1/2" PT	Crack @ 5.5 PSI
FS103009N	--	3/4" PT	Crack @ 4.0 PSI
2 Horizontal Delivery Ports (1/2" PT)			

(Mounting Bracket included)

R-12P

Valve relais Relay Valve

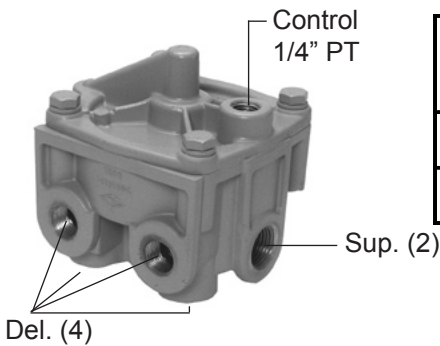

New	Reman	Sup. Ports	Notes
FS065476N	-	1/2" PT	Crack @ 4.0 PSI
4 Delivery Ports (3/8" PT), 2 Vertical & 2 Horizontal			

(Mounting Bracket included)

Section 4 . Soupapes - freins à air
 . Air Brake System Valves

**Valves relais
 Relay Valves**

R-14

New	Reman	Del. Ports	Notes
FS103028N	--	1/2" PT	Crack @ 4.0 PSI
Balance Port is under the cover 4 Vertical Delivery Ports			

(Mounting Bracket included)

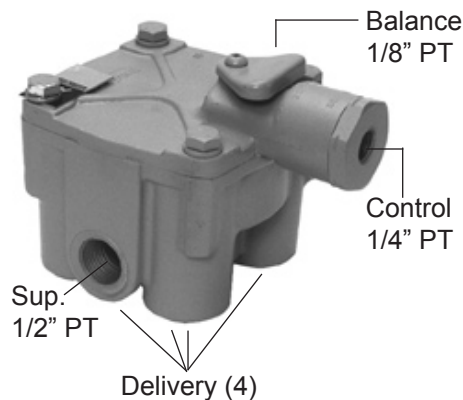

New	Reman	Del. Ports	Notes
--	FS065430X	3/8" PT	Crack @ 4.0 PSI
Balance Port is under the cover 2 Vertical and 2 Horizontal Delivery Ports			

(Mounting Bracket included)

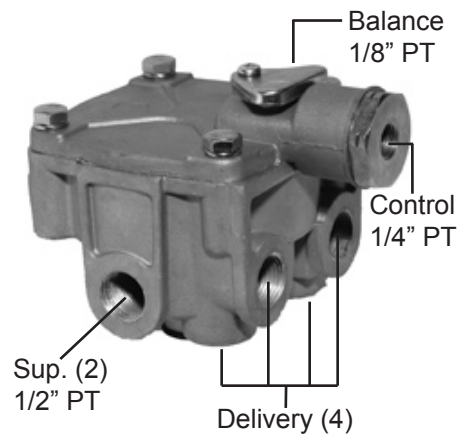

**Valve relais
 Relay Valve**

R-14H

New	Reman	Del. Ports	Notes
FS103010N	--	1/2" PT	Crack @ 4.0 PSI
Balance Port is under the cover 2 Horizontal Delivery Ports			

(Mounting Bracket included)

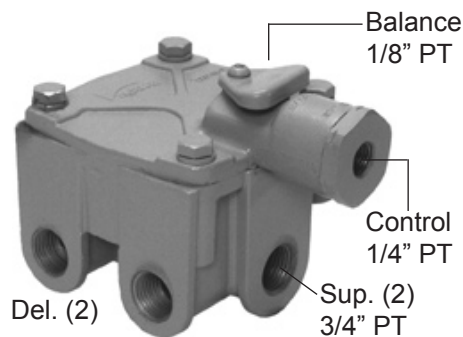

Section 4 . Soupapes - freins à air . Air Brake System Valves

RE-4

Valve relais d'urgence Relay Emergency Valve

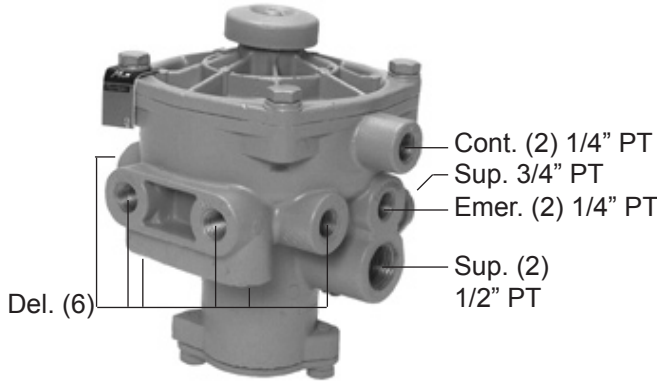

New	Reman	Del. Ports
—	FS229434X	1/4" PT

RE-6

Valves relais d'urgence Relay Emergency Valves

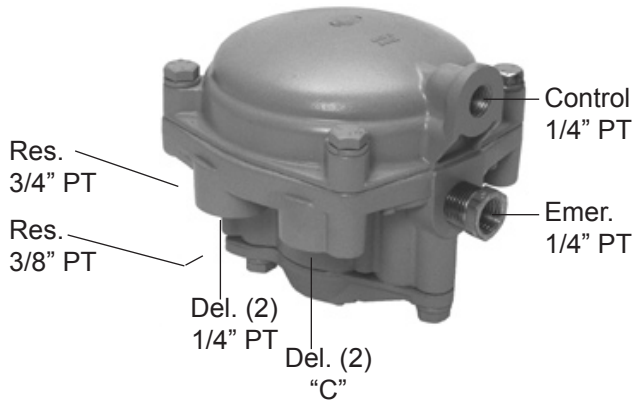

New	Reman	Del. "C" Ports
—	FS281860X	1/4" PT
FS281865N	—	3/8" PT

Section 4 .Soupapes - freins à air
 ·Air Brake System Valves

Valve de relais d'urgence - sans chargement
Relay Emergency Valve - Non Charging

RE-6NC

New	Reman	Del."C" Ports
FS065451N	FS065451X	3/8" PT

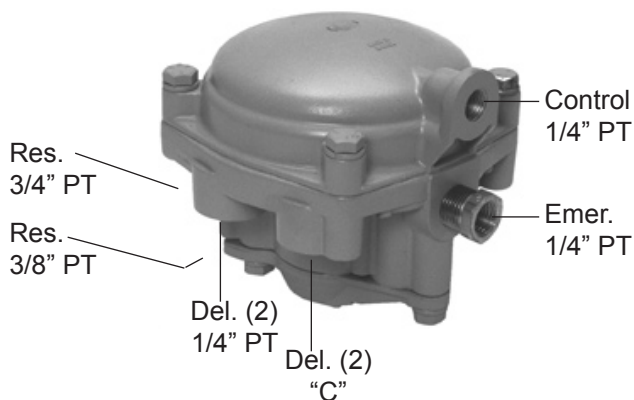

Soupape de commande par poussoir
Push type Control Valve

RD-3

New	Reman	Release	Shaft
—	FS286211X	Manual, Spring Loaded	3/8"

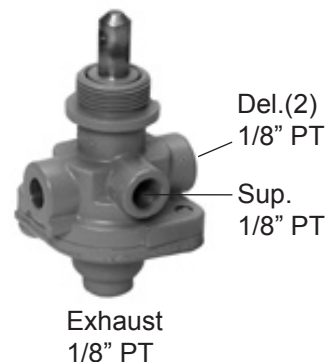

Section 4 . Soupapes - freins à air . Air Brake System Valves

RV-1

Soupape de réduction Pressure Reducing Valves



New	Reman	Notes
FS108709N	--	Preset to 25 PSI
FS277144N	FS277144X	--
FS277214N	FS277214X	Preset to 75 PSI
Pressure settings are adjustable		

SC-3

Soupapes de retenue (à sens unique) Single Check Valves



New	Inlet	Outlet
FS800372N	1/2" PT	1/2" PT
FS800375N	1/4" PT	1/4" PT

SL-4

Contacteur de feu d'arrêt Stop Light Switch

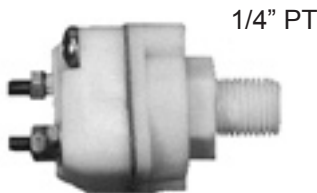

New	Reman	Terminals
FS228600N	--	#10-32
Contacts Close at 5 PSI		

Section 4 . Soupapes - freins à air
 . Air Brake System Valves

**Soupapes de cylindre de frein à air
 Spring Brake Valves**

SR-1

New	Reman	Reservoir
FS286364N	FS286364X	1/4" PT

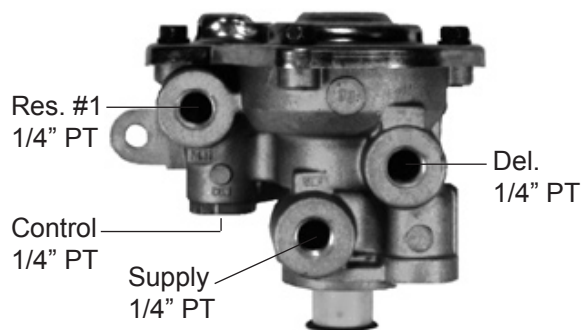

**Soupapes de cylindre de frein à air
 Spring Brake Valves**

SR-2

New	Reman	Reservoir Nipple	Anti-compounding
FS102761N**	FS102761X**	3/4" PT	Yes
** Replaces Bendix K033216			
FS103061N	FS103061X	1/2" PT	Yes
--	FS287376X	3/4" PT	No
--	FS288497X	1/2" PT	No

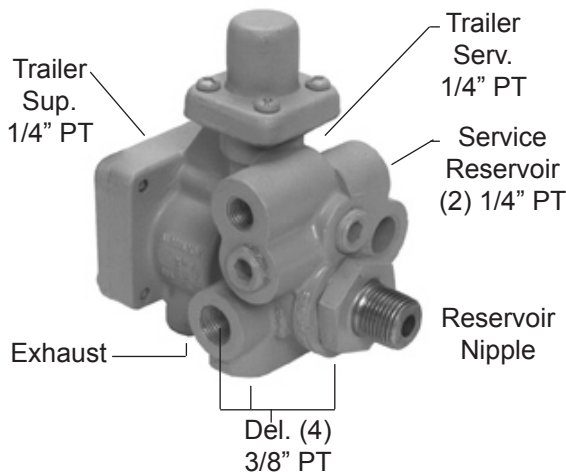

Section 4 . Soupapes - freins à air . Air Brake System Valves

SR-4

Soupapes de cylindre de frein à air Spring Brake Valves

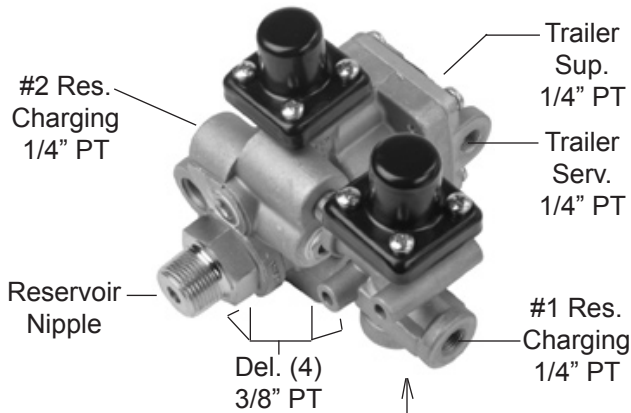

"Older" Model

New	Reman	Reservoir Nipple
FS101112N	FS101112X	3/4" PT
FS101622N	FS101622X	1/2" PT

FS286460N PR-3 Pressure Protection Valve available as a replacement part

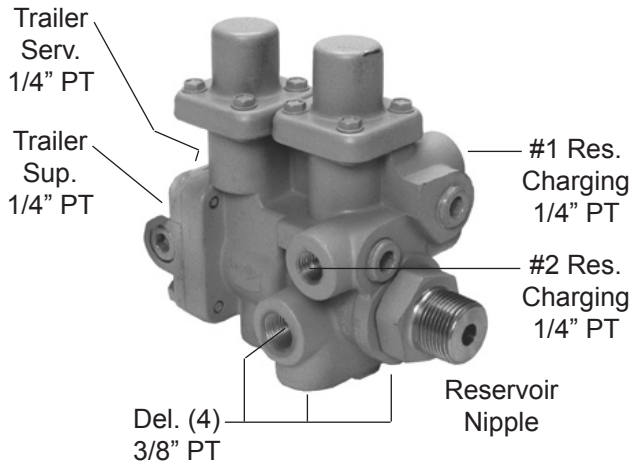

"Newer" Model

New	Reman	Reservoir Nipple
--	FS107539X	3/4" PT
FS107539 can be replaced with FS065437N		
--	FS108076X	1/2" PT

SR-5

Soupapes de cylindre de frein à air Spring Brake Valves

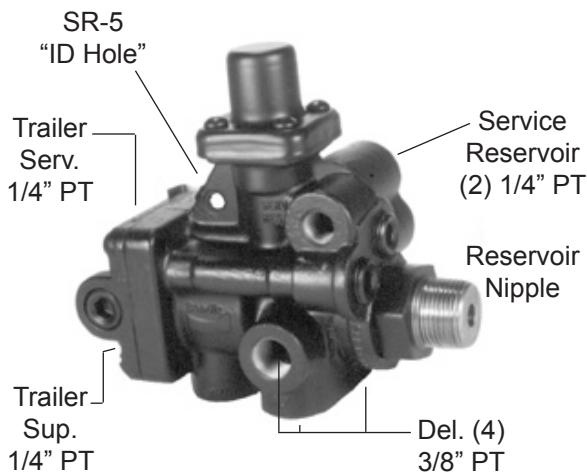

New	Reman	Reservoir Nipple	Anti-compounding
FS065437N	--	3/4" PT	Yes
Replaces: Bendix K033221			
--	FS109616X	3/4" PT	No
FS065439N	--	1/2" PT	Yes
Replaces: Bendix K033223			
--	FS109618X	1/2" PT	No

Section 4 . Soupapes - freins à air
 Air Brake System Valves

**Soupapes de cylindre de frein à air
 Spring Brake Valves**

SR-7

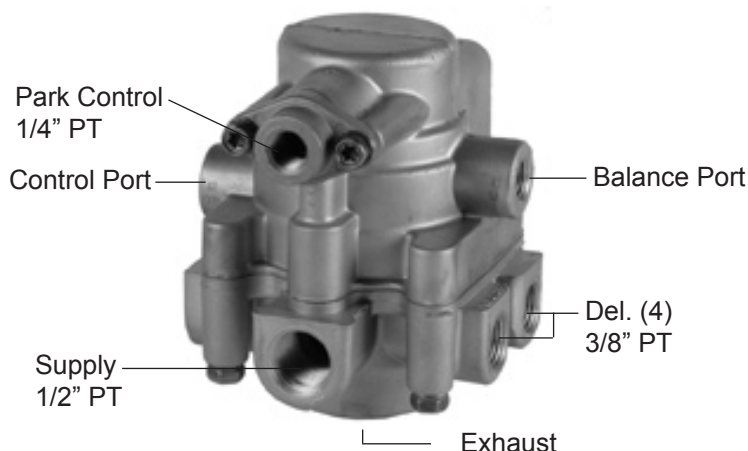

New	Reman	Mounting Stud		Control Port		Balance Port	
		Thread	Length	Size	Fitting	Size	Fitting
--	FSK021557X	3/8" - 16	15/16"	1/4" NPT	--	1/4" NPT	--
--	FSK021558X	3/8" - 16	15/16"	3/8" PTC	Straight	3/8" PTC	Straight
--	FSK021559X	3/8" - 16	15/16"	3/8" PTC	90 deg	3/8" PTC	Straight
--	FSK021560X	M10	1-3/8"	3/8" PTC	90 deg	3/8" PTC	90 deg
--	FSK021562X	--	--	1/4" NPT	--	1/4" NPT	--
--	FSK021563X	--	--	3/8" PTC	Straight	3/8" PTC	Straight

Section 4 . Soupapes - freins à air · Air Brake System Valves

ST-1

**Soupape de sûreté, ajustable
Safety Valve, Adjustable**

1/4" PT

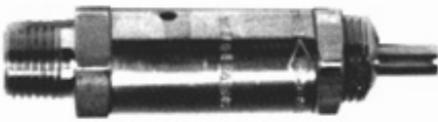

New	Reman	Pressure
FS205105N	—	Adjustable

ST-3

**Soupape de sûreté, pré réglée
Safety Valve, Fixed**

1/4" PT



New	Reman	Pressure
FS284142N	—	150 PSI

ST-4

**Soupapes de sûreté, pré réglée
Safety Valves, Fixed**

1/2" PT



1/4" PT



New	Reman	Pressure	Thread
FS131081N	—	250 PSI	1/2" PT
FS800155N	—	200 PSI	1/4" PT
FS800350N	—	150 PSI	1/4" PT

Section 4 . Soupapes - freins à air
 . Air Brake System Valves

**Soupapes synchroniseur
 Synchronizing Valves**

SV-1

New	Reman	Inlet Opens	Exh. Opens
FS278825N	--	42	28
FS282472N	FS282472X	21	11
--	* FS283700X	62	50
* With 222797 Breather Valve in Exhaust Port			

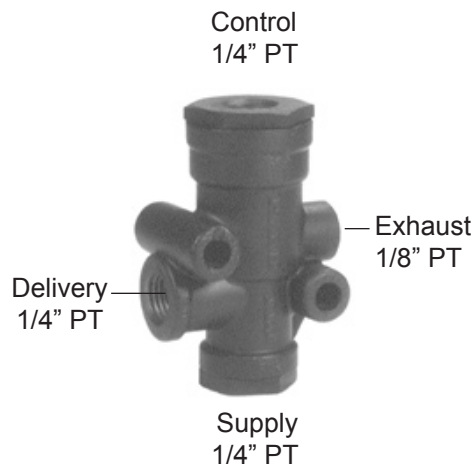

**Robinets de réglage pour remorque
 Trailer Control Valves**

TC-2

New	Reman	"A"
FS276270N	FS276270X	3-7/16"
FS276272N	FS276272X	1-1/4"

Handle and mounting brackets **not** included with Reman valves.

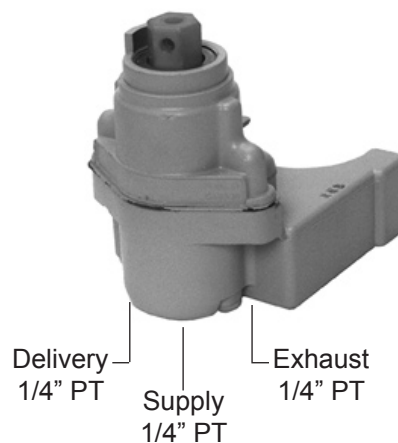
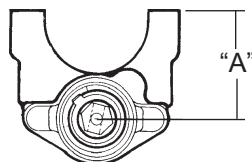

**Robinets de réglage pour remorque
 Trailer Control Valves**

TC-7

New	Reman	Final Delivery Pressure	Handle Travel	Ports
--	FS101860X	Reservoir	71° CW	1/4" PT
--	FS102707X	80 PSI	50° CW	1/4" PT
--	FS800960X	Reservoir	71° CW	P-T-C
These valves are "Holding Position" type.				
FS102423N	Handle <only> - NO Bracket			

Handle and mounting brackets **not** included.



Section 4 . Soupapes - freins à air Air Brake System Valves

TP-2

Soupapes de protection pour tracteur Tractor Protection Valves

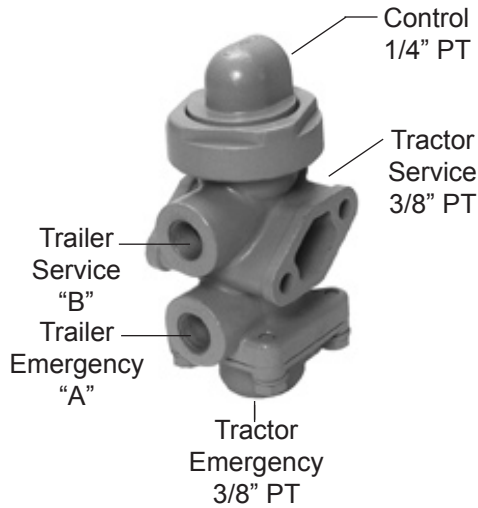

New	Reman	Trailer Emerg. (A)	Trailer Serv. (B)
--	FS227661X	3/8" PT	3/8" PT
--	FS227672X	1/2" PT	1/2" PT

TP-3

Soupapes de protection pour tracteur Tractor Protection Valves

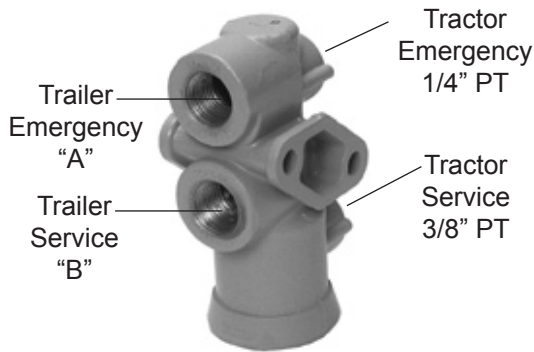

New	Reman	Trailer Emerg. (A)	Trailer Serv. (B)
FS279000N	--	1/2" PT	1/2" PT
--	FS279692X	3/8" PT	3/8" PT

TP-3DC

Soupapes de protection pour tracteur Tractor Protection Valves

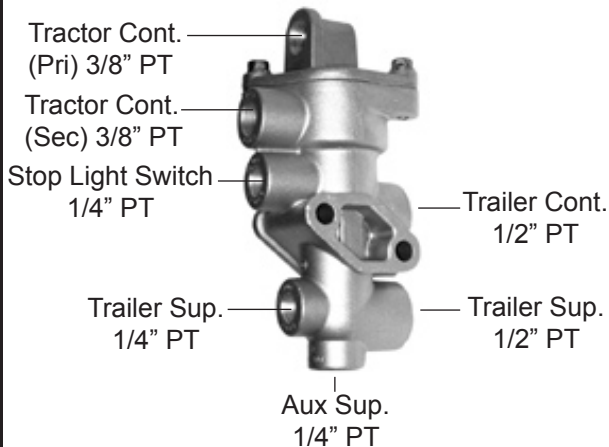

New	Reman
FS065706N	FS065706X

Section 4 . Soupapes - freins à air
 Air Brake System Valves

Soupape de protection pour tracteur
Tractor Protection Valve

TP-4

New	Reman
—	FS288301X
Exclusive to Ford "L" model Tractors. Formerly VM-1 Control Valve.	

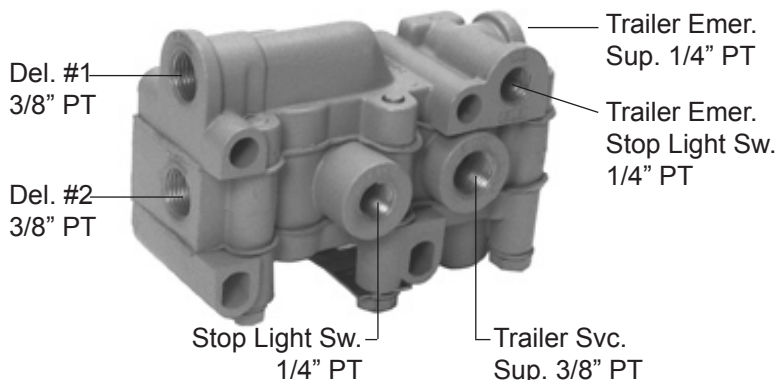

Soupapes de protection pour tracteur
Tractor Protection Valves

TP-5

New	Reman	Notes
--	FS106941X	for Mack
FS288605N	FS288605X	--
--	FS289253X	when TC-2 is NOT connected
--	FS5000284X	Push-to-Connect fittings
--	FS800396X	Push-to-Connect (most) fittings
(Formerly known as VM-2 Control valve)		

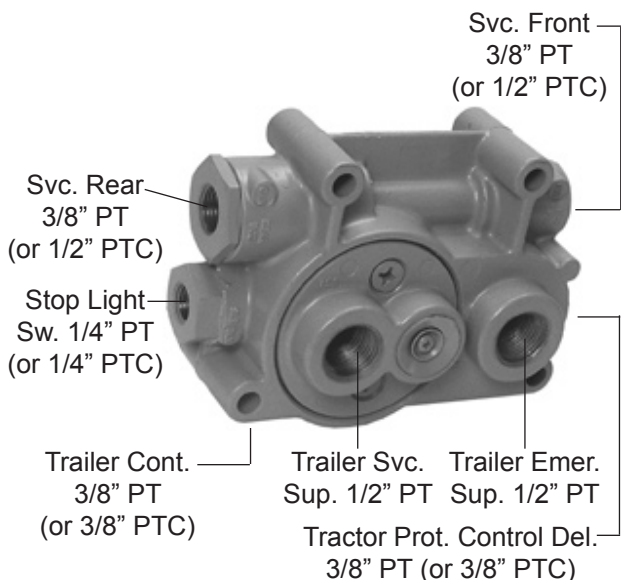

Section 4 . Soupapes - freins à air Air Brake System Valves

TR-2

Valve relais d'inversion Inversion Valve

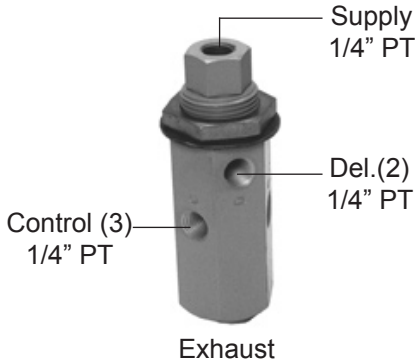

New	Reman	Ports
--	FS277340X	1/4" (6)

TR-3

Valves relais d'inversion Inversion Valves

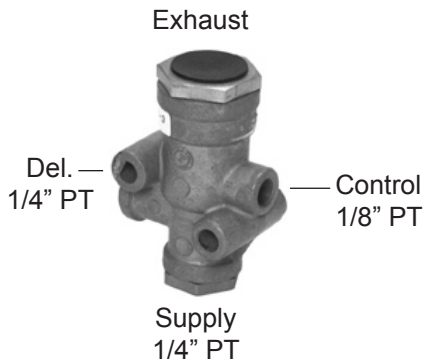

New	Reman	Inlet Opens	Exhaust Opens
FS280758N	FS280758X	45 PSI	60 PSI
FS281318N	FS281318X	35 PSI	70 PSI
FS281459N	FS281459X	25 PSI	40 PSI

TW-1

Soupape de réglage opérée par levier Lever Operated Control Valve

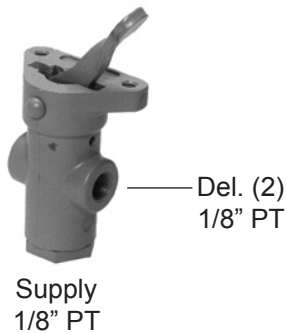

New	Reman	Ports	Notes
FS229635N	--	1/8" PT	2 Lever positions

TW-2

Soupapes de réglage opérée par levier Lever Operated Control Valves

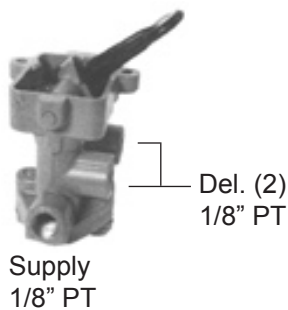

New	Reman	Ports	Notes
FS280905N	FS280905X	1/8" PT	2 Lever positions
Normal use: To control Parking & Emergence Brakes			

Section 4 . Soupapes - freins à air
 Air Brake System Valves

Soupapes de réglage opérée par levier
Lever Operated Control Valves

TW-3

New	Reman	Ports	Notes
FS225892N	FS225892X	1/4" PT	2 Lever positions
Normal use: To control Parking & Emergence Brakes Slightly greater capacity than TW-1 valve.			



Del. (2)
 1/4" PT

Supply
 1/4" PT

Soupapes de réglage opérée par bouton-poussoir
Push Button Control Valves

TW-4

New	Reman	Ports	Notes
FS276635N	--	1/8" PT	Button NOT included
FS236241N	--	N/A	Button Kit for TW-4
Normal use: Air Starter system			



Del. (2)
 1/8" PT

Supply
 1/8" PT

Mounting Brackets for BP-R1, R-12 and R-14 valves

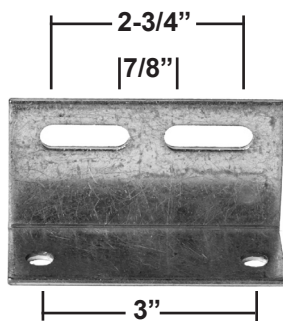

FS296010N
 "Universal"

FS294314N
 "Standard"

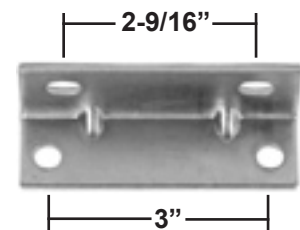

Propriété exclusive de FleetSpec. Toute reproduction interdite. / Exclusive property of FleetSpec. Reproduction prohibited.

Section 4 . Soupapes - freins à air
· Air Brake System Valves

Valves relais à haut débit
Hi-Flow Relay Valves

New	Reman	Del. Ports	Notes
B12343N	B12343X	4	--
--	B12347X	2	--

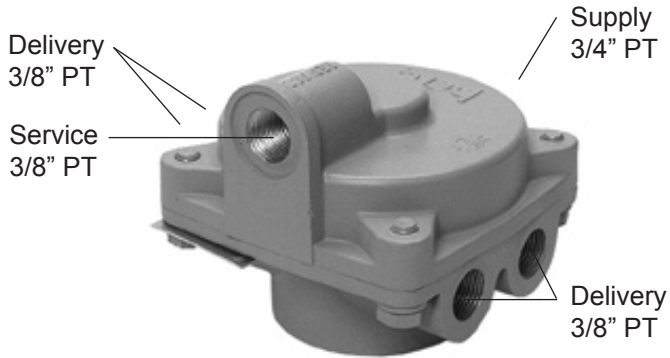

(B12343X Shown)

Valve relais
Relay Valve

New	Reman	Del. Ports	Notes
--	B12350X	4	**
** For trailers without Spring Brakes			

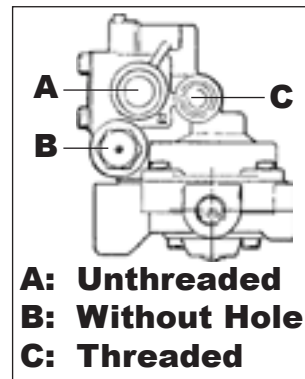
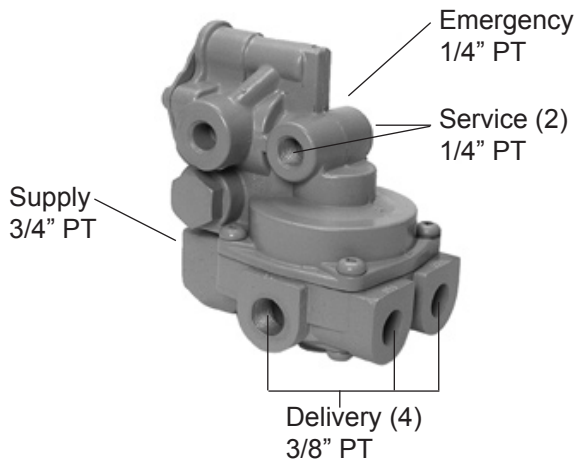

Section 4 . Soupapes - freins à air . Air Brake System Valves

Soupape S.E.R.V. S.E.R.V. Valve

New	Reman	Del. Ports	Notes
B12352N	B12352X	2	**
** Service Emergency Relay Valve			

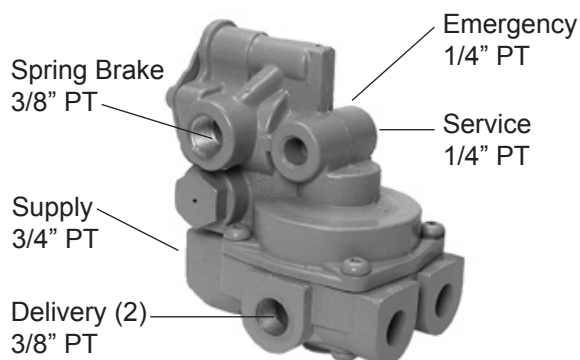
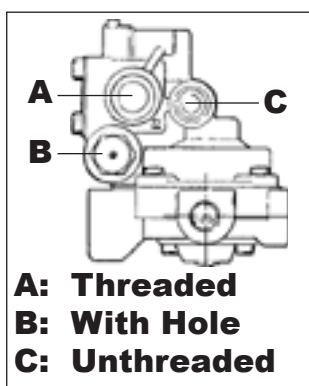

Soupapes de tâche Task Valves

New	Reman	Del. Ports	Notes
—	B12360X	4	Anti-Compounding
—	B12361X	4	—
Controls spring brakes on single or dual axle trailers.			

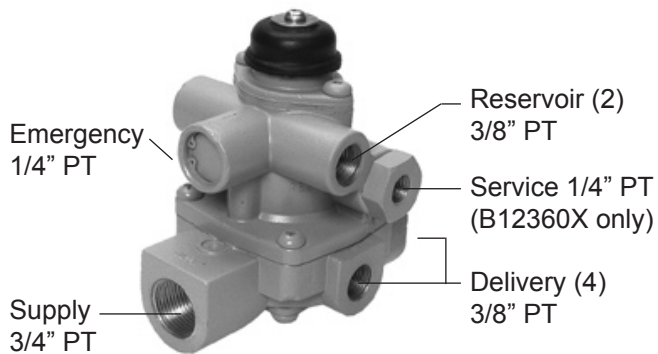

(B12360X Shown)

Section 4 . Soupapes - freins à air · Air Brake System Valves

Soupapes de retenue (à sens unique) One-Way Check Valves

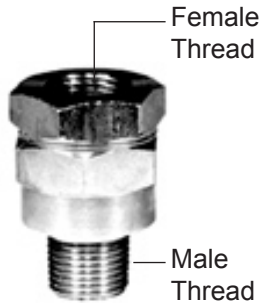

New	Fitting Size	Replaces
FS-11209	3/8" PT	Midland KN23010
FS-11210	1/2" PT	Midland KN23000

Clapet de pied à circuit unique Single Circuit Foot Valve

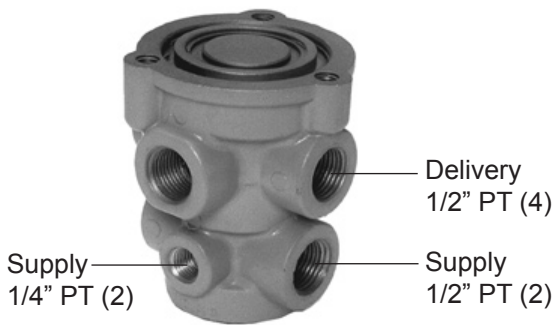

New	Reman
—	FSKN22100X

* Used primarily with pre FMVSS-121 vehicles.

Clapet de pied à double circuit Dual Circuit Foot Valve

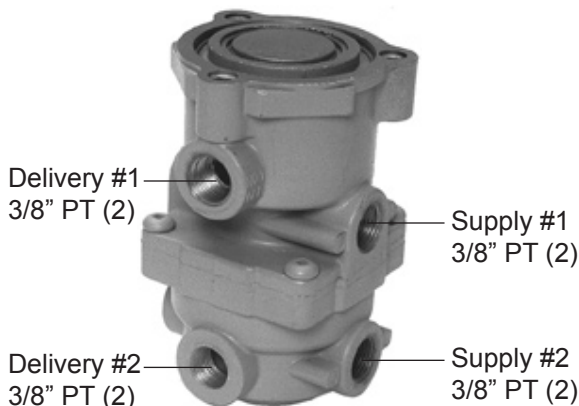

New	Reman
—	FSKN22140X

Section 4 . Soupapes - freins à air Air Brake System Valves

Soupapes de remorque "Full-Function" Full-Function Trailer Valves

FF-2

New	Reman	Reservoir Nipple
FSKN28600N	FSKN28600X	3/4" PT
FSKN28601N	FSKN28601X	1/2" PT
Crack @ 3 PSI		

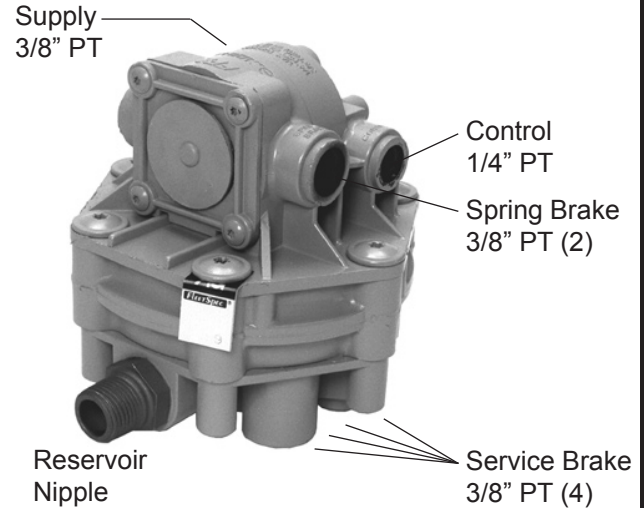

Valve relais d'inversion Inversion Valve

New	Reman	Notes
--	FSKN28030X	All ports (4) 1/4" PT

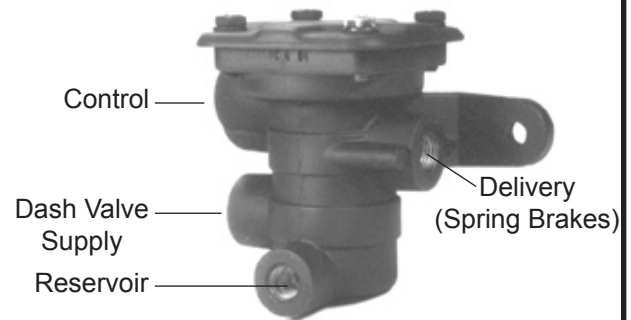

Modules de commande Manifold Dash Modules

New	Reman	Mounting Holes (4)
--	FSKN20606X	1/4"-20
--	FSKN20607X	M6
--	FSKN20612X	10-24
--	FSKN20615X	1/4" Hole
All ports (6) 1/4" PT		

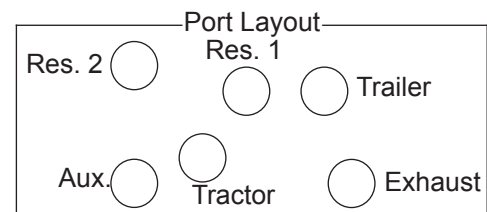

Section 4 . Soupapes - freins à air . Air Brake System Valves

Valves de desserrage rapide Quick Release Valves, with 2-Way Check

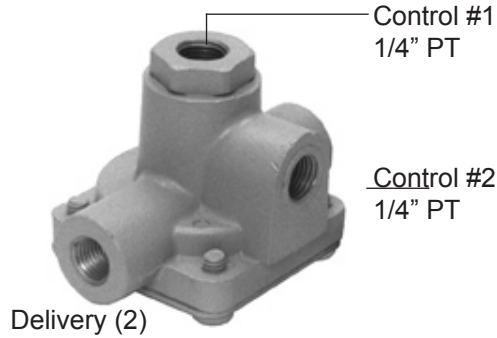

New	Reman	Delivery Ports
–	FSKN32040X	1/4" PT
–	FSKN32041X	3/8" PT

Valves relais - 2 orifices d'alimentation Relay Valves - 2 Delivery

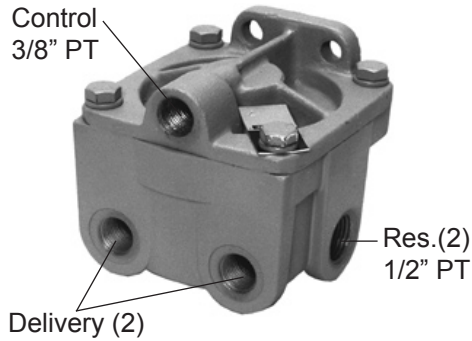

New	Reman	Del.	Crack PSI
FSKN28060N	FSKN28060X	3/8	4.6
--	FSKN28061X	1/2	4.6
--	FSKN28300X	1/2	0.0

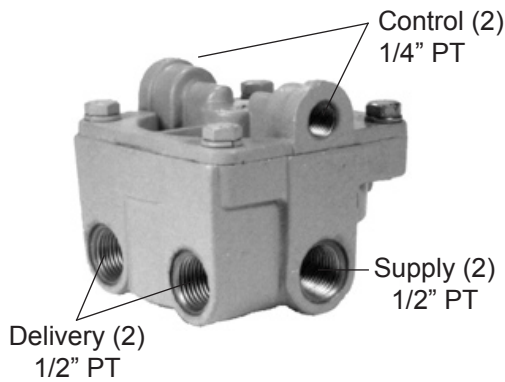

New	Reman	Del.	Crack PSI
–	FSKN28065X	1/2	4.6

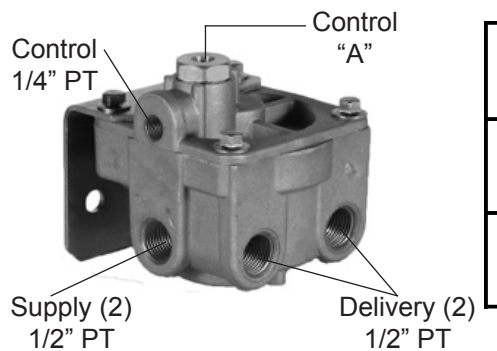

New	Reman	"A"	Crack PSI
FSKN28071N	FSKN28071X	1/4" or 1/8"	4.6
Features built-in anti-compounding, and 2-way check valve for Spring Brake control.			

Propriété exclusive de FleetSpec. Toute reproduction interdite. / Exclusive property of FleetSpec. Reproduction prohibited.

Section 4 . Soupapes - freins à air . Air Brake System Valves

Valve relais - 2 orifices d'alimentation Relay Valve - 2 Delivery

New	Reman	"A"	Crack PSI
--	FSKN28131X	1/4"	4.0

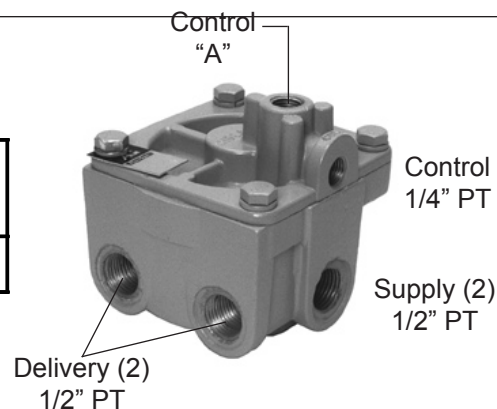

New	Reman	"A"	Crack PSI
--	FSKN28140X	1/4"	4.0

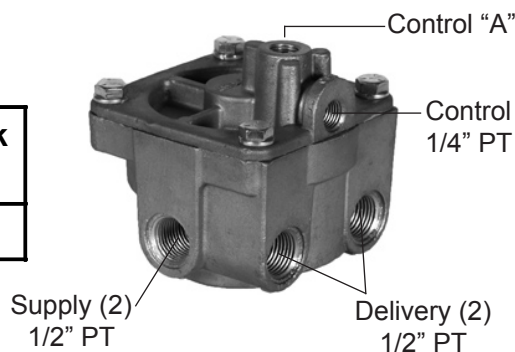

Valve relais - 4 orifices d'alimentation Relay Valve - 4 Delivery

New	Reman	Del. (4)	Crack PSI
FSKN28080N	FSKN28080X	3/8	7.0

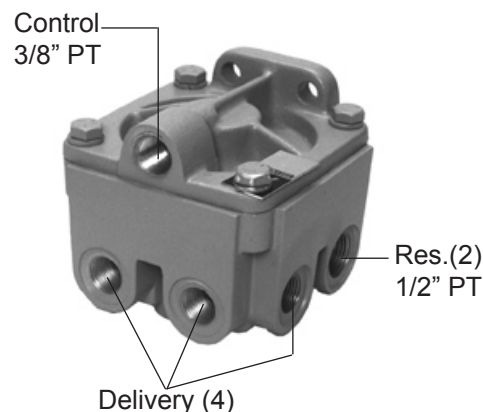

Valve relais - monté sur cadre Relay Valve - Frame Mounted

New	Reman	Del. (2)	Crack PSI
--	FSKN28130X	1/2	4.6

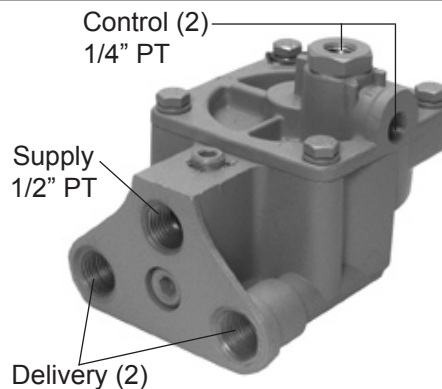

Section 4 . Soupapes - freins à air . Air Brake System Valves

Valves relais d'urgence Emergency Relay Valves

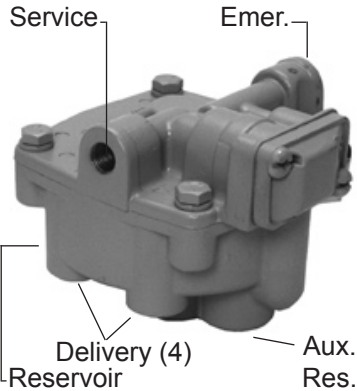

New	Reman	Svc.& Emer.	Del. (4)	Aux Res.	Res.
--	FSKN30200X *	3/8"	3/8"	1/2"	X
FSKN30300N	FSKN30300X	1/4"	1/4"	X	3/4"
FSKN30400N	FSKN30400X	1/4"	3/8"	X	3/4"
* FSKN30200X is Non-Charging All Crack @ 4.5 PSI			X = plugged		

RG-2

Valves relais - 2 orifices d'alimentation Relay Valves - 2 Delivery

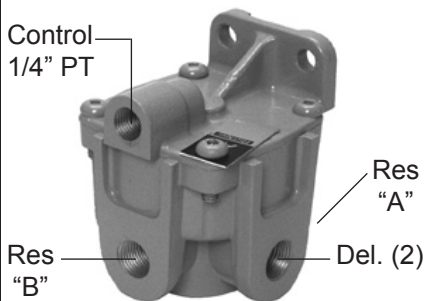

New	Reman	Res. "A"	Res. "B"	Del (2)
FSKN28500N	--	3/8"	3/8"	3/8"
FSKN28510N	--	3/8"	1/2"	3/8"
FSKN28520N	--	1/2"	1/2"	1/2"
--	FSKN28531X	1/2"	3/8"	3/8"
All Crack @ 6.0 PSI				

RG-5

Valve relais - 2 orifices d'alimentation Relay Valve - 2 Delivery

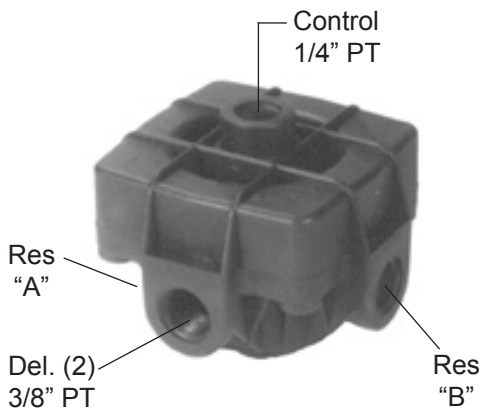

New	Reman	Res. "A"	Res. "B"
--	FSKN28551X	X	3/8"
Crack @ 6.0 PSI		X = plugged	

Section 4 . Soupapes - freins à air . Air Brake System Valves

Soupapes de remorque multi-fonction Multi-function Trailer Valves

RT-4

New	Reman	Sup. "A"	Sup. "B"	Sup. "B" over	Trailer Cont. over	PPV Closing
FSKN26000N	FSKN26000X	3/8"	3/8"	Res "B"	Res "A"	55 PSI
—	FSKN26010X	3/8"	X	Res "A"	Res "B"	70 PSI
FSKN26020N	FSKN26020X	X	3/8"	Res "B"	Res "A"	70 PSI

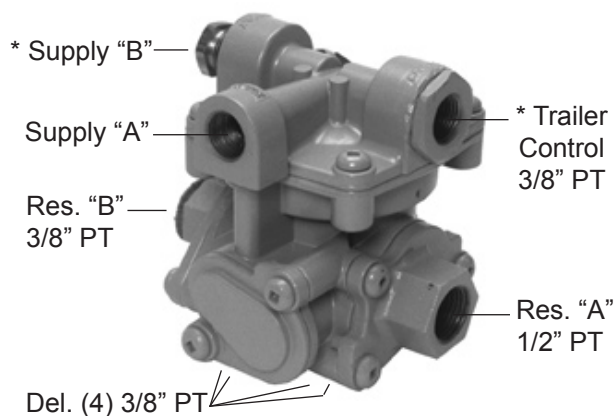

Robinet de commande de frein pour remorque Trailer Brake Control - In-column Mount

New	Reman	Action	Del.& Sup.	Exh.
—	FSKN20541X	Holding	1/4"	1/4"

Handle applies 50° maximum. Handle not included.

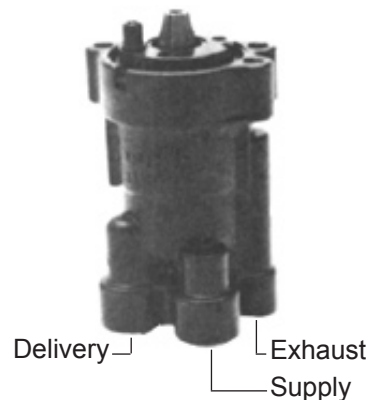

Section 4 . Soupapes - freins à air · Air Brake System Valves

Soupape de protection pour tracteur

3 conduites automatique, avec echappement rapide
Tractor Protection Valve - 3 line automatic, with Quick Release

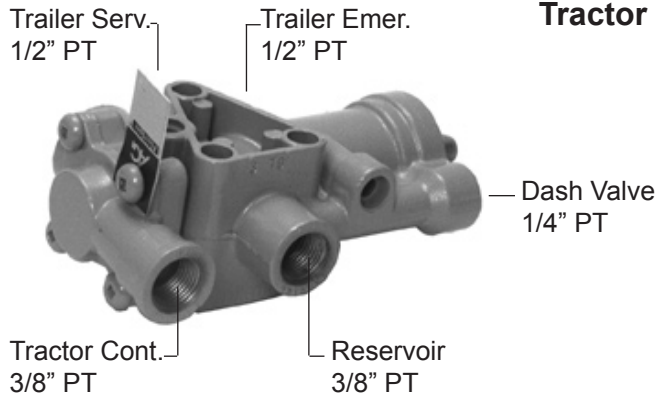

New	Reman
—	FSKN34050X

Soupape de protection pour tracteur

2 conduites, non-automatique, avec echappement rapide
Tractor Protection Valve - 2 line, non-automatic, with Quick Release

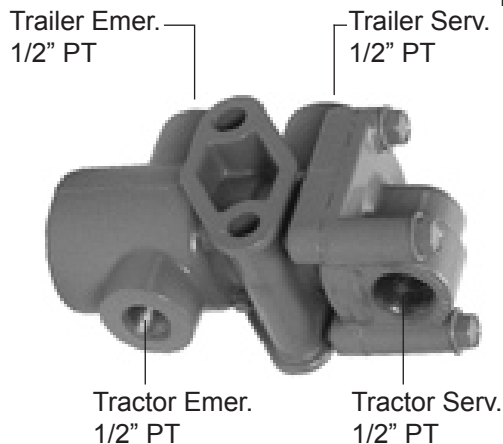

New	Reman
—	FSKN34060X

Soupape de protection pour tracteur

3 conduites automatique, sans echappement rapide
Tractor Protection Valve - 3 line automatic, without Quick Release

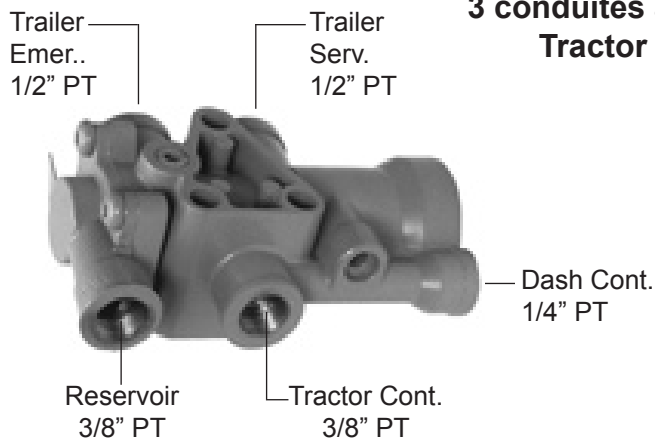

New	Reman
—	FSKN34070X

Section 4 . Soupapes - freins à air . Air Brake System Valves

Soupapes de protection pour tracteur 2 conduits, style manifold Tractor Protection Valves - 2 line, Manifold style

New	Reman	"A"	"B"	Notes
–	FSKN34080X	3/8"	3/8"	"Ford" Vehicles
–	FSKN34090X	3/8"	1/2"	"Navistar" Vehicles
–	FSKN34100X	X	3/8"	"Ford" Vehicles
–	FSKN34110X	X	1/2"	"Navistar" Vehicles

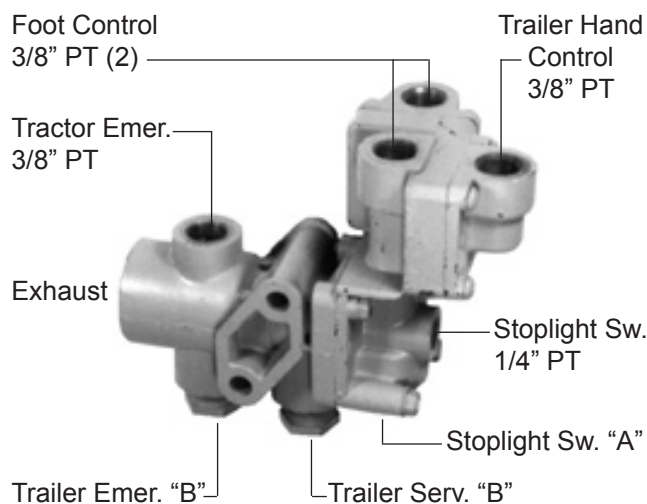

Soupapes déflecteur double Double Flipper Valves

New	Reman	Notes
–	FSKN20080X	3 positions, with manual release only.
–	FSKN20090X	3 positions, with automatic release when Supply "A" is applied.
–	FSKN20110X	2 positions, with manual release only.

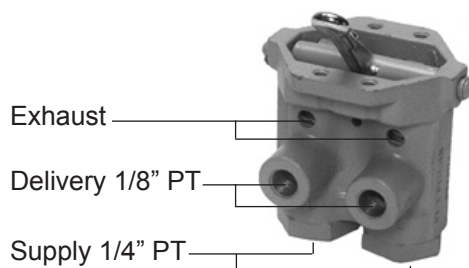

Propriété exclusive de FleetSpec. Toute reproduction interdite. / Exclusive property of FleetSpec. Reproduction prohibited.

Section 4 . Soupapes - freins à air · Air Brake System Valves

RF

**Valve relais - 4 orifices d'alimentation
Relay Valve - 4 Delivery**

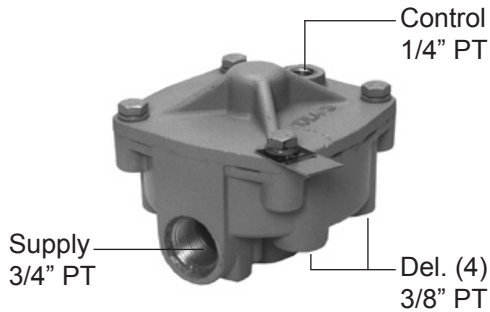

New	Reman	Crack PSI
--	WA103600X	3.0
4 Vertical Delivery Ports, Single Control		

RG-4

**Valve relais tandem
Tandem Relay Valve**

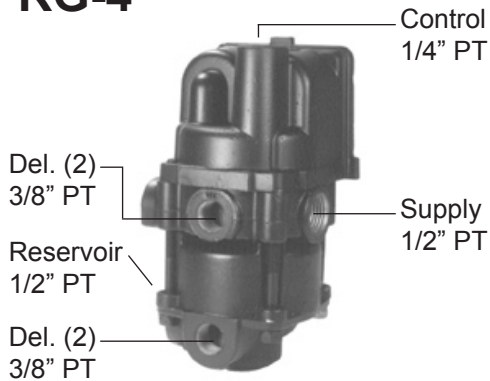

New	Reman
--	WA85490X

RT

**Soupapes de cylindre de frein à air pour remorque
Trailer Spring Brake Valves**

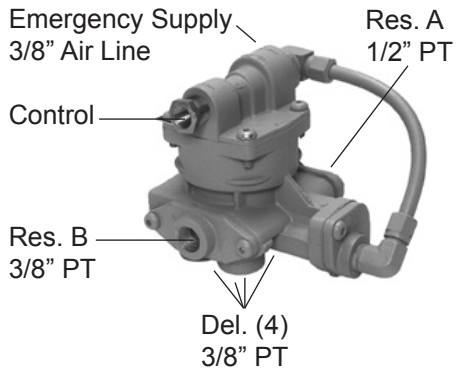

New	Reman	Cont. PT	Notes
--	WA88802X	3/8"	Anti-Compounding
--	WA88812X	X	--

RT-2

**Soupape de cylindre de frein à air pour remorque
Trailer Spring Brake Valve**

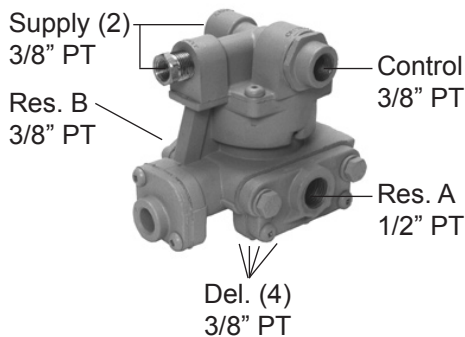

New	Reman	Notes
--	WA98730X	Anti-Compounding

Section 4 . Soupapes - freins à air Air Brake System Valves

Valve relais - 2 orifices d'alimentation Relay Valve - 2 Delivery

New	Reman	Delivery Ports
—	KH5468X	3/8" (2)
2 Horizontal Delivery Ports.		

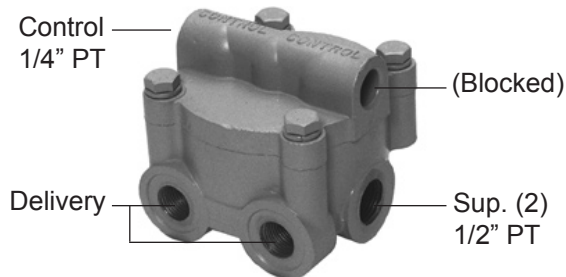

Valve relais - 4 orifices d'alimentation Relay Valve - 4 Delivery

New	Reman	Delivery Ports
—	KH5470X	3/8" (2) 1/2" (2)
4 Vertical Delivery Ports.		

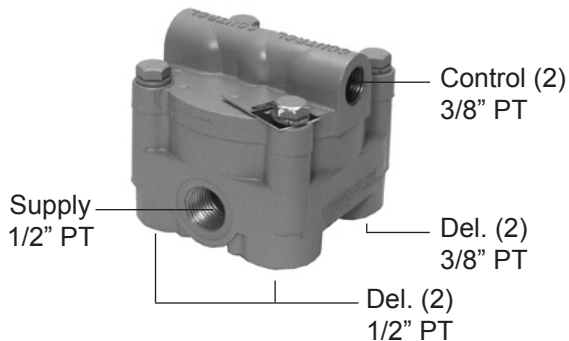

Notes

Section 4 . Soupapes - freins à air . Air Brake System Valves

Valves de protection Pressure Protection Valves



New	Reman	Nominal Opening	Nominal Closing
SE140200N	--	60 PSI	50 PSI
SE140270N	--	70 PSI	60 PSI
SE140280N	--	80 PSI	70 PSI

Valve de desserrage rapide de conduite In-line Quick Release Valve

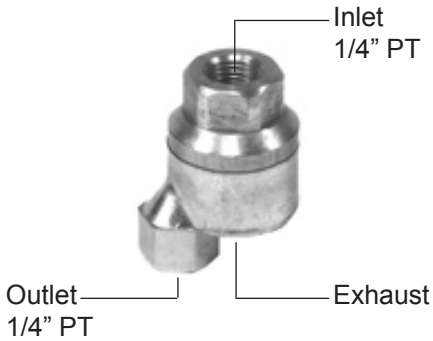

New	Reman
SE3800N	SE3800X

Filtre de conduit d'alimentation Supply Line Filter



New	Reman	Notes
SE2550N	--	Both ports 3/8" PT
Replaces: Sealco 2550 * Filter is easily serviced. * Helps to filter out contaminants before they reach critical Air Brake components. <*> Must mount with the Red Cap DOWNWARDS. <*> NOT for use in the Control Line.		

Section 4 . Soupapes - freins à air Air Brake System Valves

Valves relais - 2 orifices d'alimentation Service Relay Valves - 2 Delivery

New	Reman	Crack PSI
SE110197N	SE110197X	4.0

New	Reman	Crack PSI
SE110360N	SE110360X	1.5
SE110410N	SE110410X	4.0

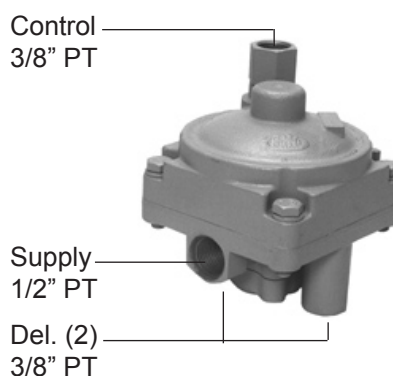

Valves relais - 4 orifices d'alimentation Service Relay Valves - 4 Delivery

New	Reman	Ratio Feature
SE110139N	SE110139X	Yes
--	SE110450X	No
--	SE110600X *	Yes
Crack @ 4.5 PSI		
* Aux. Supply capped on SE110600		

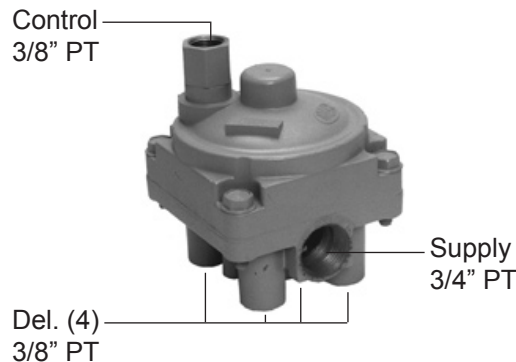
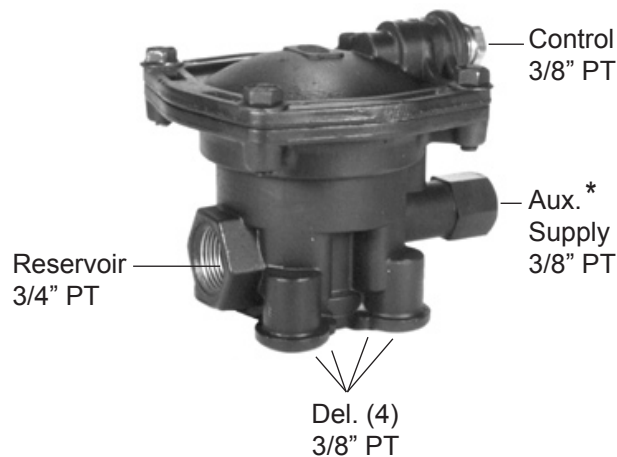

New	Reman	Crack PSI
SE110380N	SE110380X	1.5
SE110415N	SE110415X	4.0

Section 4 . Soupapes - freins à air · Air Brake System Valves

Valves relais - 3 orifices d'alimentation Service Relay Valves - 3 Delivery

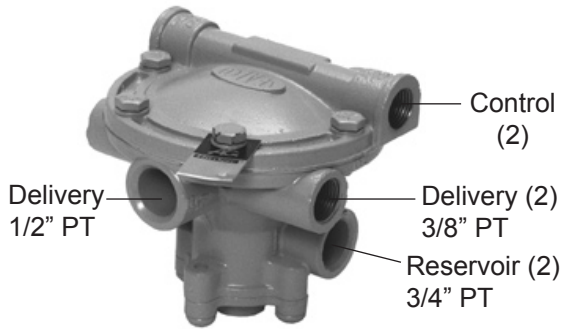

New	Reman	Cont. PT	Crack PSI
—	SE110207X	3/8"	5.5
—	SE9125X	1/4"	5.5

Soupape de conduit de control - diabloconvertisseurs & essieux autovireur Control Line Valve - Dollies & Turntable Axles

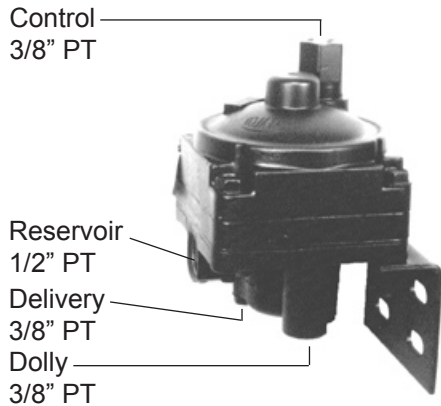

New	Reman	Crack PSI
SE110570N	SE110570X	0

Soupape de conduit de control - remorques Control Line Valve - Trailers

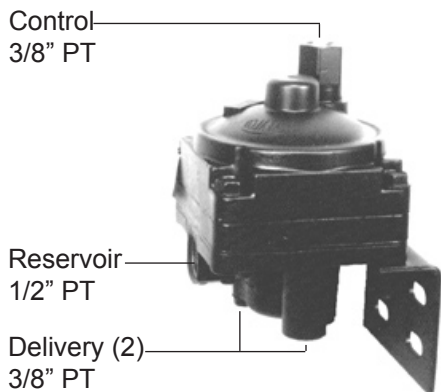

New	Reman	Crack PSI
SE110580N	SE110580X	0

Section 4 . Soupapes - freins à air . Air Brake System Valves

Soupape mini - 2 orifices d'alimentation Mini Valve - 2 Delivery

New	Reman	Crack PSI	Notes
SE3100N	SE3100X	2.5	—

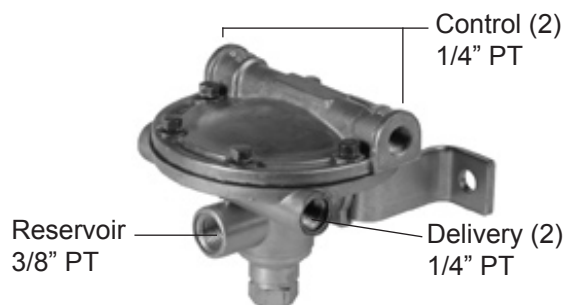

Soupape à retour automatique Auto Reset Control Valve

New	Reman	Notes
--	SE110555X	All ports (3) 1/4" PT

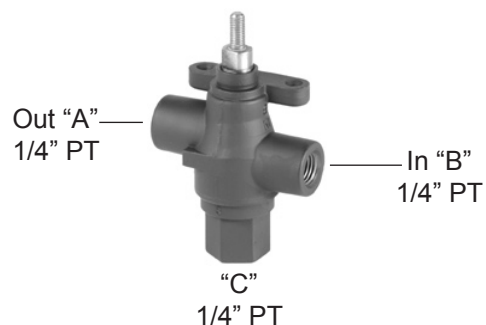

Valve de contrôle push-pull Push-Pull Hand Control Valve

New	Reman	Notes
SE17600BN	--	All ports (3) 1/4" PT

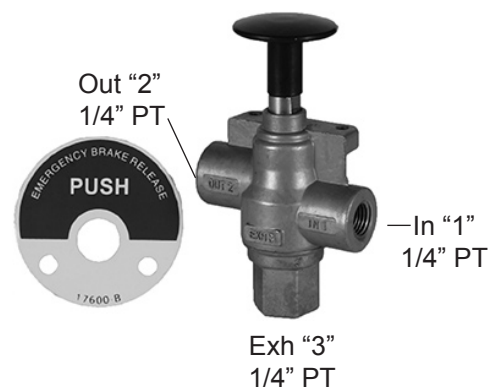

Valve de contrôle push-pull Auto Shut-off Push Pull Valve

New	Reman	Notes
SE99600BN	--	All ports (3) 1/4" PT
Auto Shut-off @ 30 PSI ± 5 PSI		

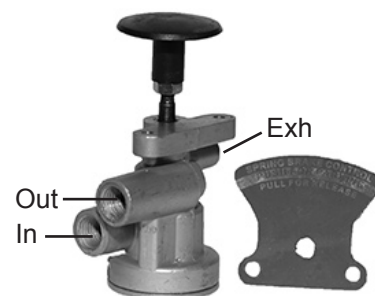

Section 4 . Soupapes - freins à air . Air Brake System Valves

Valves relais d'urgence - 4 orifices d'alimentation Charging Relay Emergency Valves - 4 Delivery

New	Reman	Supply PT	Control PT	Ratio * feature
SE110200N	SE110200X	1/4"	1/4" (2)	YES *
--	SE110205X	3/8"	3/8" (2)	YES *
--	SE110460X	1/4"	1/4" (2)	No
--	SE110470X	3/8"	3/8" (2)	No
--	SE110475X	3/8"	3/8" (2)	No

* Do NOT use Ratio Feature valves on Converter Dollies or Trailer Turntable Axles.

- All valves Nominal Crack Pressure @ 4.5 PSI

** 3/8" Supply Out port on SE110475 <only>

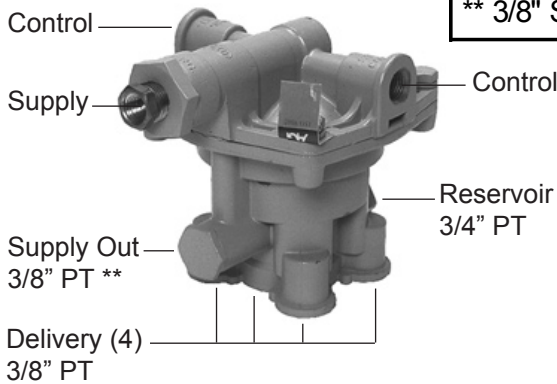

Valve relais d'urgence - 4 orifices d'alimentation Relay Emergency Valve - 4 Delivery

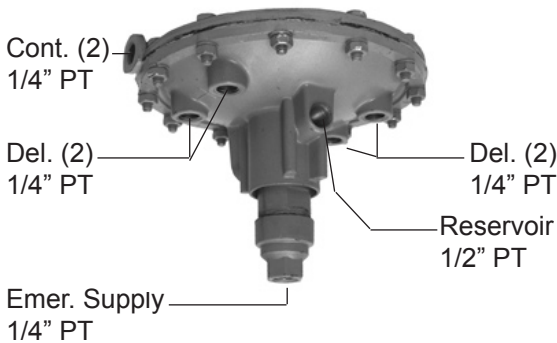

New	Reman	Crack PSI
SEA1000SN	SEA1000SX	1.5

Cartouche pour valve relais d'urgence Cartridge for Relay Emergency Valve



New	Reman
--	SEA1000-5AX

Section 4 . Soupapes - freins à air · Air Brake System Valves

Valve relais d'urgence - 4 orifices d'alimentation Non-Charging Relay Emergency Valve - 4 Delivery

New	Reman	Crack PSI
SE110338N	SE110338X	4.5

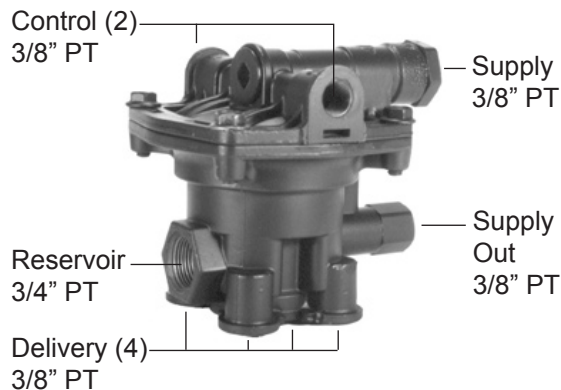

Soupape de contrôle de cylindre de frein à air - 4 orifices d'alimentation Spring Brake Control Valve - 4 Delivery

New	Reman	Notes
--	SE110148X	--

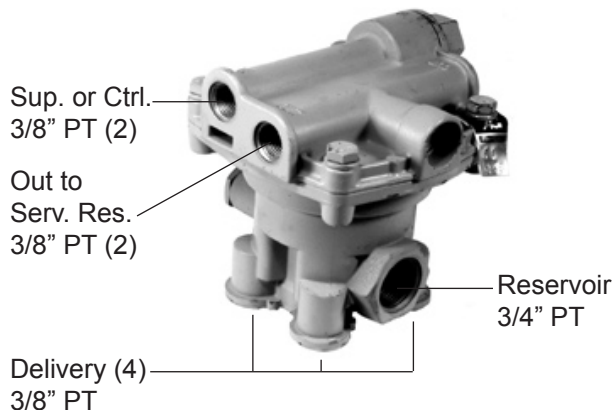

Soupapes de contrôle de cylindre de frein à air - 4 orifices d'alimentation Spring Brake Control Valves - 4 Delivery

New	Reman	"A" PT	"B" PT
SE110170N	SE110170X	1/2"	1/2"
SE110310N	SE110310X	3/8"	1/2"
SE110315N	SE110315X	1/2"	3/8"

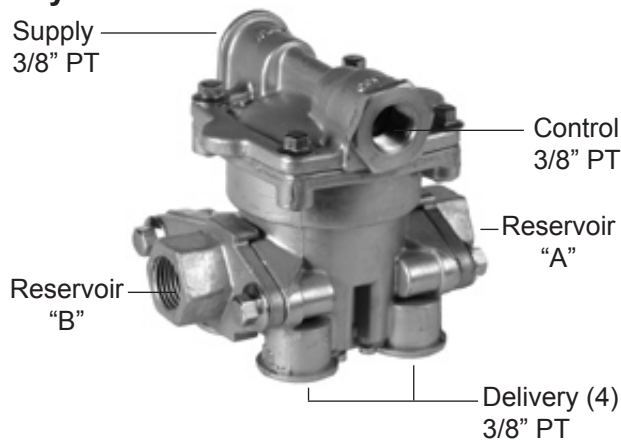

Section 4 . Soupapes - freins à air . Air Brake System Valves

Soupapes de contrôle de cylindre de frein à air - 4 orifices d'alimentation Spring Brake Control Valves - 4 Delivery

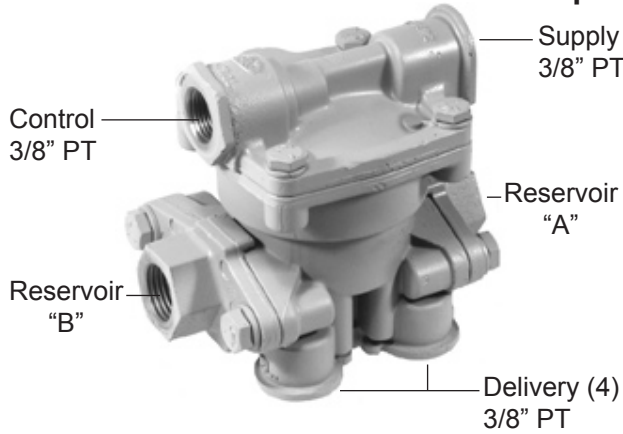

New	Reman	"A" PT	"B" PT
SE110171N	SE110171X	1/2"	3/8"
SE110191N	SE110191X	3/8"	1/2"

Soupape préférentiel de cylindre de freins à air Spring Brake Priority Valve

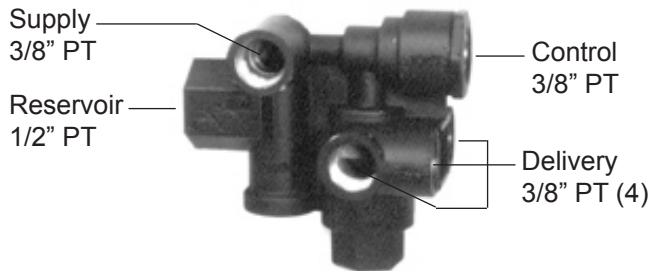

New	Reman	Notes
SE110500N	SE110500X	Opens at approximately 80 PSI

Soupapes préférentiel du réservoir de service Service Reservoir Priority Valves

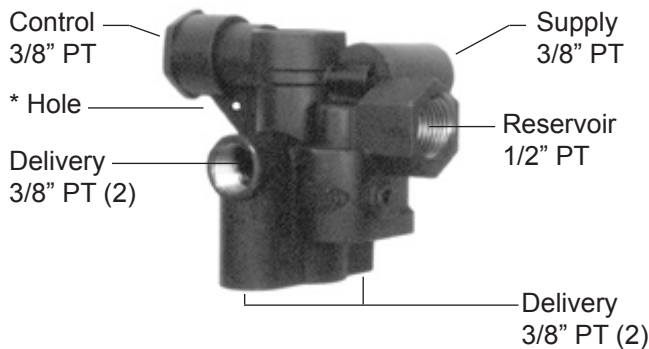

New	Reman	Notes
SE110700N	--	* NO hole
SE110800N	--	* With Hole
Opens at approximately 80 PSI		

FleetSpec

Section 4 . Soupapes - freins à air Air Brake System Valves

Clapet de pied à circuit unique Single Circuit Foot Valve

New	Reman	Notes
--	SE6125-2X	--

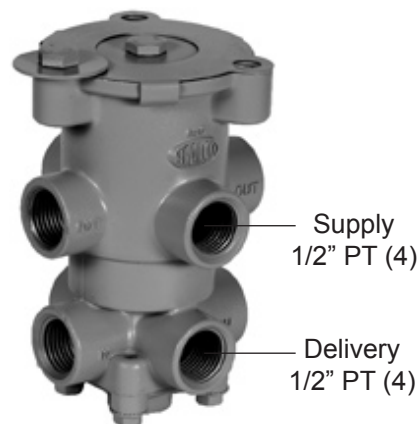

Clapet de pied à double circuit Dual Circuit Foot Valve

New	Reman	Notes
--	SE110400X	--

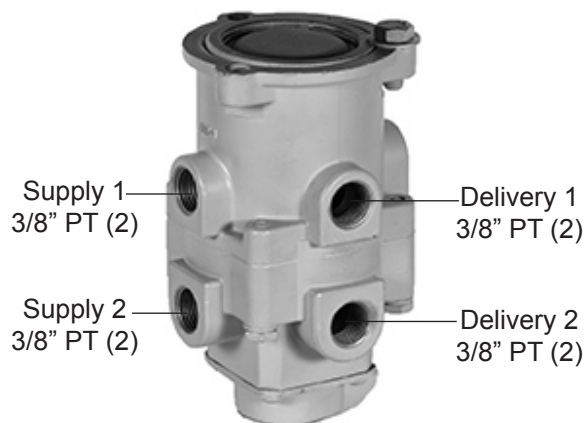

Valve d'urgence pour remorques Trailer Emergency Valve

New	Reman	Notes
FST51301N	--	--
Replaces: Tramec TEV 51301		

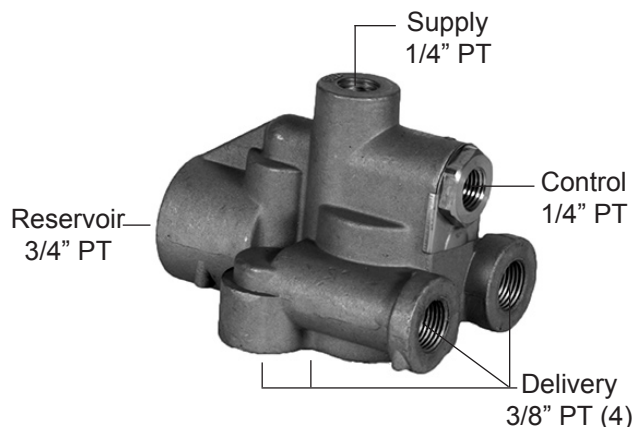

Section 4 . Soupapes - freins à air
· Air Brake System Valves

Soupape modulatrice à haut débit
High Flow Modulating Valve

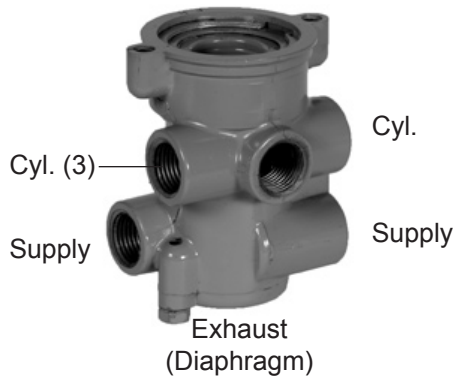

New	Reman	Notes
--	FSWM112468X	All ports (5) are 1/2" PT
Replaces: WM352A		

Treadle is **not** included

Soupape régulatrice 3-voie
3-Way Regulating Valve

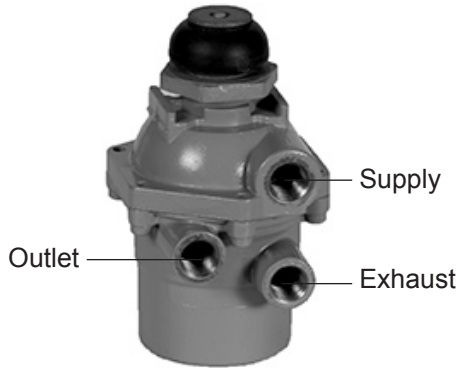

New	Reman	Notes
--	FSWM111276X	All ports (3) are 1/4" PT

Replaces: WM90A
Max Supply Pressure is 150 PSI.
Output Range from 0-120 PSI.
Stroke is 0.38" (10 mm).
Note: For Off-Highway Applications.

Actuator and mounting bracket **not** included

Valve de protection
Pressure Protection Valve



New	Notes
FS-6596	* Normally Closed. Opens at 70 PSI. * Max. operating pressure: 150 PSI. * with Filter in Inlet Port.
Replaces: Williams WM778A1, 118181 Manac 023-150	

Valve de protection à pression ajustable
Adjustable Pressure Protection Valve

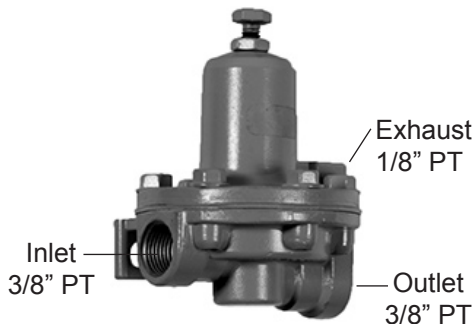

New	Reman	Notes
--	FSWM111263X	Adjust between 0-80 PSI

Replaces: WM87C
Max supply pressure is 150 PSI.
> When Supply Pressure drops below Adjusted Pressure, Outlet side is exhausted.

Section 4 . Soupapes - freins à air
 . Air Brake System Valves

Soupape de sûreté
Emergency Safety Valve

New	Reman	Notes
--	FSWM112215X	Normally closed, Pull to open

Replaces: WM321
 Valve automatically closes between 35-45 PSI.
 Manual actuation needs min. supply pressure of 35 PSI.
 Max Supply pressure is 150 PSI.

Knob and Escutcheon plate **not** included

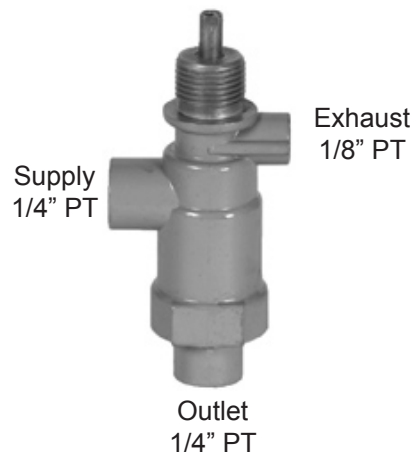

Soupape de contrôle pour réservoir auxiliaire
Auxiliary Tank Control Valve

New	Reman	Notes
--	FSWM111913X	All ports (3) are 1/4" PT

Replaces: WM271A
 Max Supply Pressure is 150 PSI.
 > When the button is OUT (normal), air flows from the Emergency Supply to the Outlet.
 > When the button is IN, air flows from Aux Supply.
 Button resets (out) when:
 1) Manually pulled out, or
 2) Emergency Supply PSI is greater than Outlet PSI.

Knob and Escutcheon plate **not** included

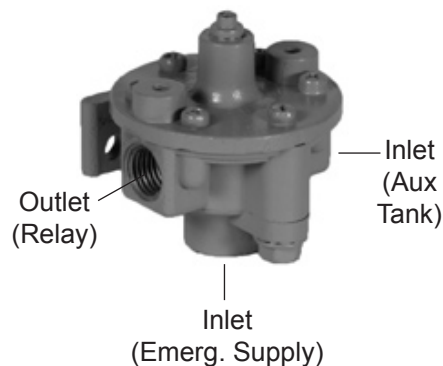

Soupape de commande de frein de stationnement
Parking Brake Control Valve

New	Reman	Notes
--	FSWM112229X	Pull to Release, Push to Apply

Replaces: WM325
 Valve automatically closes between 25-40 PSI.
 Manual actuation needs min. supply pressure of 35 PSI.
 Max Supply pressure is 150 PSI.

Knob and Escutcheon plate **not** included

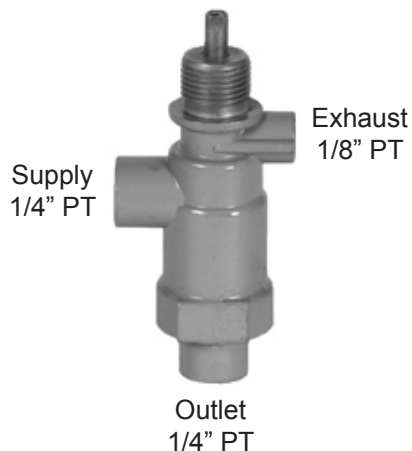

Section 4 . Soupapes - freins à air · Air Brake System Valves

Soupape de commande 2-position, 4-voie 2 Position, 4-Way Control Valve

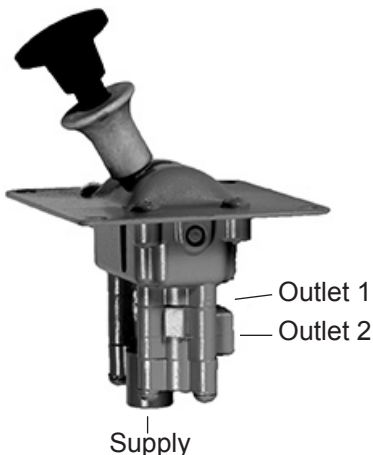

New	Reman	Notes
--	FSWM118316X	All ports (3) are 1/8" PT
Replaces: WM782A Handle features a Spring-loaded Lockout. > When the Handle is in Position 1, Outlet 1 is exhausted, and Outlet 2 is supplied air. > When the Handle is in Position 2, Outlet 2 is exhausted, and Outlet 1 is supplied air.		

Soupape régulatrice à opération manuelle Hand Operated Regulating Valves

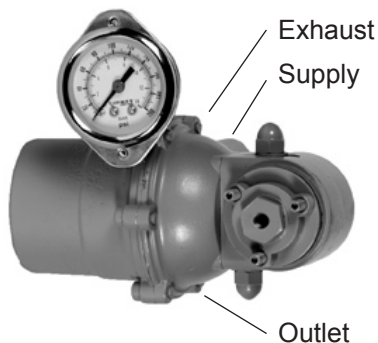

New	Reman	Notes
--	FSWM113726X	All ports (3) are 1/4" PT
Replaces: WM606C1C Output Range from 0-120 PSI. Pressure Gauge included		

Handle and mounting bracket **not** included

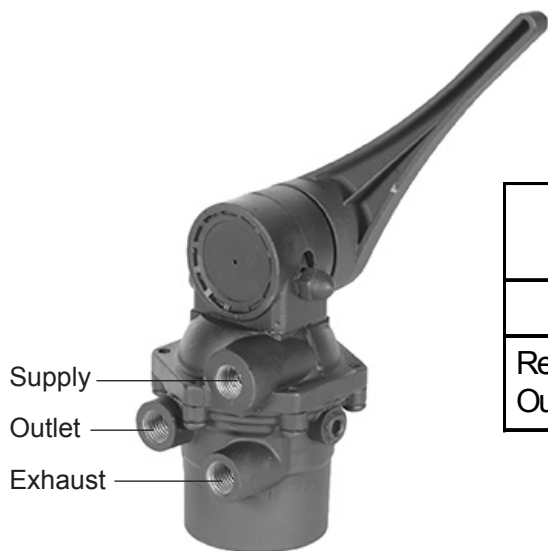

New	Reman	Notes
--	FSWM113730X	All ports (3) are 1/4" PT
Replaces: WM606 Output Range from 0-120 PSI.		

Mounting bracket is **not** included

Section 4 . Soupapes - freins à air
 · Air Brake System Valves

Soupape de protection pour tracteur
Tractor Protection Valve

New	Reman	Notes
--	FSWM112211X	Ports (5) are 1/4" PT Exhaust port un-threaded
Replaces: WM320A Cracks @ 1.5 PSI. Fixed 1:1 Output/Control Pressure Ratio. > As Control Pressure decreases, Outlet pressure is Exhausted to match Control Pressure.		

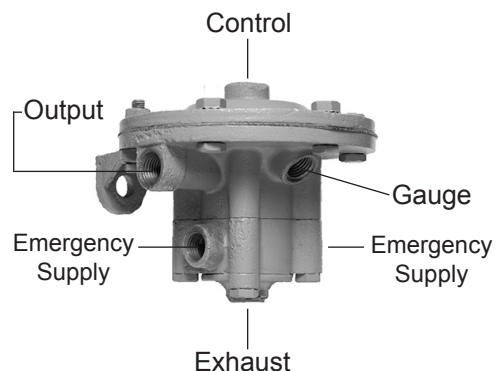

Valve relais à haut débit
High Volume Compensating Relay Valve

New	Reman	Notes
--	FSWM111999X	Cracks @ 3.0 PSI
Replaces: WM292B Flange or 3/4" PT Nipple mounting option.		

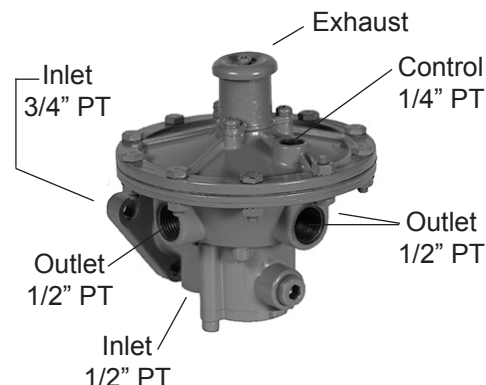

Valve relais à ratio
Ratio Relay Valve

New	Reman	Notes
--	FSWM112201X	Ports (4) are 1/4" PT Exhaust port un-threaded
Replaces: WM318A Cracks @ 1.5 PSI > Output is adjustable between 20% less than, and 30% more than the Control Pressure.		

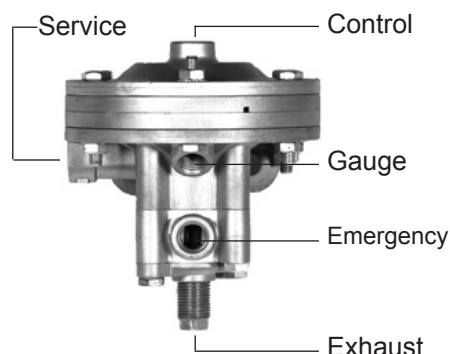

Section 4 . Soupapes - freins à air · Air Brake System Valves

Valves relais d'urgence Emergency Relay Valves

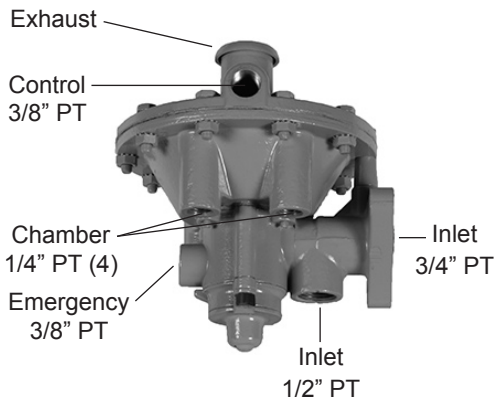

New	Reman	Notes
--	FSWM100361X	Cracks @ 3-4 PSI
Replaces: WM101P Flange or 3/4" PT Nipple mounting option. 4 Vertical 1/4" PT Chamber Ports.		

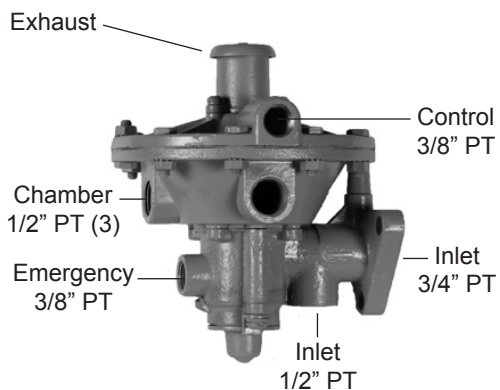

New	Reman	Notes
--	FSWM100362X	Cracks @ 3-4 PSI
Replaces: WM101R Flange or 3/4" PT Nipple mounting option. 3 Horizontal 1/2" PT Chamber Ports.		

Valve de desserrage rapide Quick Release Valve

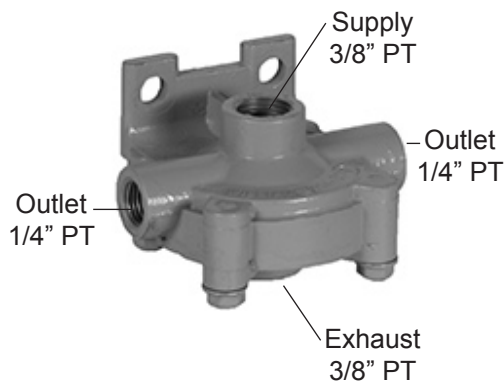

New	Reman	Notes
--	FSWM112173X	--
Replaces: WM314B		

Section 4 . Soupapes - freins à air Air Brake System Valves

Valves relais Relay Valves

New	Reman	Type	"A" 1/4" PT	"B" 1/8" PT	Closes @ PSI	Reopens @ PSI	Replaces Williams:
FSWM147C	--	NC	Control	Exhaust	--	15-30	111527
FSWM147F	--	NO	Exhaust	Control	30-50	15-30	111531
--	FSWM147LX	NC	Control	Exhaust	--	35-45	130845
FSWM147P	--	NO	Exhaust	Control	10-30	5-10	111542

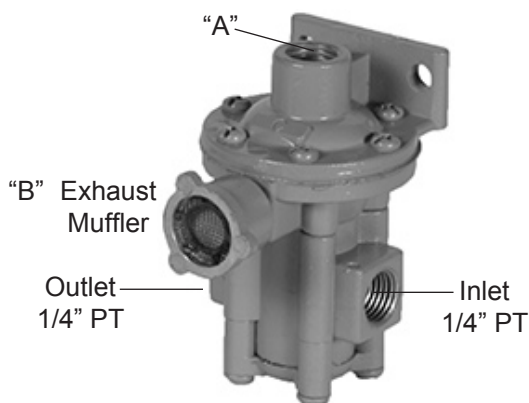

FSWM147C (and L) shown here

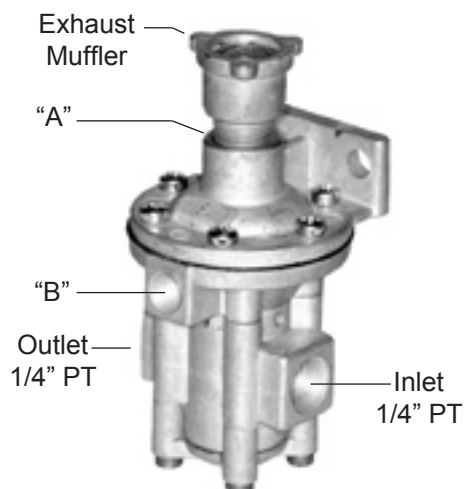

FSWM147F (and P) shown here

New	Reman	Notes
--	FSWM112371X	Ports (3) are 1/4" PT
Replaces: WM338P Normally Open, Adjustable from 2 to 120 PSI to close. To be mounted with adjustment screw facing up.		

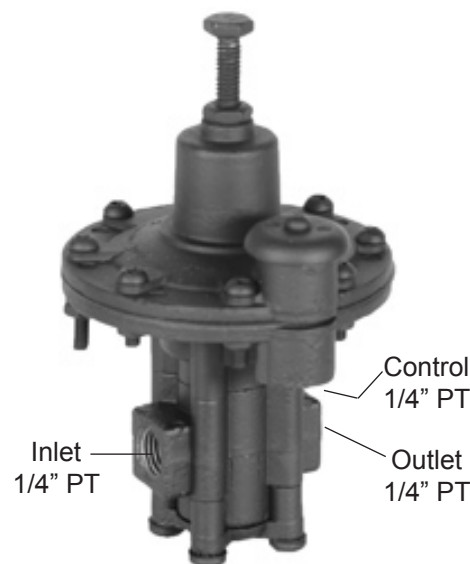

Section 4 . Soupapes - freins à air . Air Brake System Valves

Soupapes de retenue (à sens unique) One-Way Check Valves

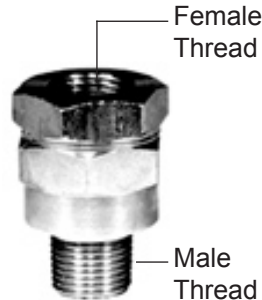

New	Fitting Size	Replaces
FS-11209	3/8" PT	Midland KN23010
FS-11210	1/2" PT	Midland KN23000

Soupapes d'écoulement Drain Valves



New	Cable Length
FS-5173	5 Foot, plus Ferrule
FS-5173-4	4 Foot, Looped
FS-5173-6	5 Foot, Looped
FS-5173-1	Replacement Ferrule <only>



New	Cable Length
FS-5172-6	5 Foot, Looped

Soupapes de sûreté Safety Valves

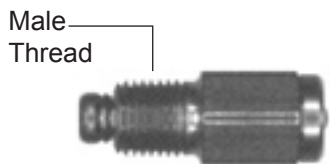

New	Notes
FS-11034	Safety Valve, 3/8" PT (150 PSI)
Replaces: Wabco S2206-D-1226	



Section 5

Systeme de freins ABS
Anti-Lock Brake System

Section 5 · Système de freins ABS · Anti-Lock Brake System

Capteurs ABS ABS Sensors



ABS180-0.4MDB

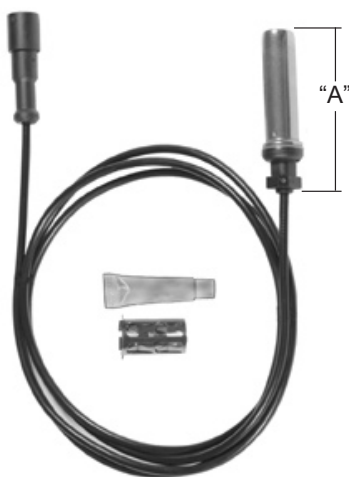

Capteurs droit / Straight Sensor For Disk Brake

New	Length	"A"	Can replace
ABS180-0.4MDB	0.4M	60.6mm	* Meritor S4410350010

Note: * Sensor comes with a Spring Clip,
and a tube of Installation Lubricant.
* Sensor is 10.9mm in diameter.

Capteurs droit / Straight Sensors

New	Length	"A"	Can replace
ABS180-0.6M	0.6M	79mm	* Haldex AL1027194 * Haldex AL1027196
ABS180-1.8M65MM	1.8M	65mm	* Meritor R955337 * Meritor R955329
ABS180-1.8M79MM	1.8M	79mm	* Meritor R955338
ABS180-2.0M	2.0M	79mm	* Haldex AL1027197 * Meritor R955349

Notes: * All sensors come with a Spring Clip,
and a tube of Installation Lubricant.
* Sensors are 16mm in diameter

Capteur à angle droit / Right-Angle Sensors

New	Length	"A"	Can replace
ABS090-0.3M	0.3M	57mm	* Meritor R955335
ABS090-0.5M	0.5M	57mm	* Haldex AL10271914
ABS090-0.9M	0.9M	57mm	* Meritor R955336
ABS090-1.5M	1.5M	57mm	* Meritor R955365
ABS090-1.8M	1.8M	57mm	* Meritor R955341 * Meritor R955328
ABS090-2.0M	2.0M	57mm	* Meritor R955342 * Haldex AL10271915

Note: * All sensors come with a Spring Clip,
and a tube of Installation Lubricant.
* Sensors are 16mm in diameter.

Section 5 .Système de freins ABS .Anti-Lock Brake System

Câbles de ralonge pour capteur ABS ABS Sensor Extension Cables

Ralonge droit / Straight Extensions		
New	Length	Can replace
ABSE180-1.5M	1.5M	* Haldex AL919802
ABSE180-2.0M	2.0M	* Haldex AL919803
ABSE180-2.5M	2.5M	* Haldex AL919804
ABSE180-3.0M	3.0M	* Haldex AL919805
ABSE180-3.5M	3.5M	* Haldex AL919806

Note: 2-conductor cables, with Haldex/Meritor connector.



Ralonge angle droit / Right-Angle Extensions		
New	Length	Can replace
ABSE090-1.8M	1.8M	* Meritor S4497130180
ABSE090-3.0M	3.0M	* Meritor S4497130300
ABSE090-5.0M	5.0M	* Meritor S4497130500

Note: 2-conductor cables, with Haldex/Meritor connector.



Attache pour capteurs ABS Sensor Spring Clips	
New	Notes
ABS0001	* For sensors with a diameter of 16mm. * Comes with a tube of Installation Lubricant Replaces : Bendix 801534 Meritor R955458
ABS0002	* For sensors with a diameter of 10.9mm. * Comes with a tube of Installation Lubricant



Section 5 . Système de freins ABS . Anti-Lock Brake System

Capteurs ABS ABS Sensors



DT04 Connector

DIN Connector



Capteur Droit / Straight Sensors *DT04 Connector*

New	Length	Can replace
ABS180-1.0MBEN	1.0M	* Bendix 801553
ABS180-1.9MBEN	1.9M	* Bendix 801552

Capteur Droit / Straight Sensors *DIN Connector*

New	Length	Can replace
ABS180-1.7MBEN	1.7M	* Bendix 801543
ABS180-2.0MBEN	2.0M	* Bendix 801542

Note: * All sensors come with a Spring Clip, and a tube of Installation Lubricant.

* Sensors are 16mm in diameter

Capteur à angle droit / Right-Angle Sensors *DT04 Connector*

New	Length	Can replace
ABS090-1.0MBEN	1.0M	* Bendix 801551
ABS090-1.5MBEN	1.5M	* Bendix 801549
ABS090-2.0MBEN	2.0M	* Bendix 801550

Capteur à angle droit / Right-Angle Sensors *DIN Connector*

New	Length	Can replace
ABS090-0.3MBEN	0.3M	* Bendix 801544
ABS090-1.9MBEN	1.9M	* Bendix 801538

Note: * All sensors come with a Spring Clip, and a tube of Installation Lubricant.

* Sensors are 16mm in diameter



Attache pour capteur ABS Sensor Spring Clip

New	Notes
ABS0001	Comes with a tube of Installation Lubricant Replaces Bendix 801534

Section 5 .Système de freins ABS
·Anti-Lock Brake System

Notes

Propriété exclusive de FleetSpec. Toute reproduction interdite. / Exclusive property of FleetSpec. Reproduction prohibited.

Section 5 . Système de freins ABS . Anti-Lock Brake System

ATR-6

Valve traction-relais Traction Relay Valve

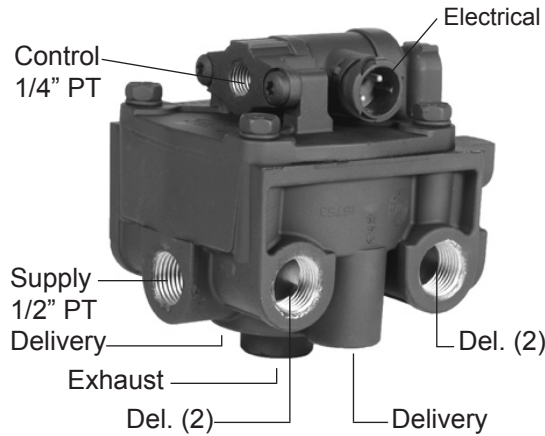

Relay Valve	Voltage	Notes
FS803121X	12 V	4 x 1/2" Horizontal DEL ports 2 x 3/8" Vertical DEL ports
Twist-Lock Electrical Connector		

M-21

Modulateur ABS ABS Modulator Valve

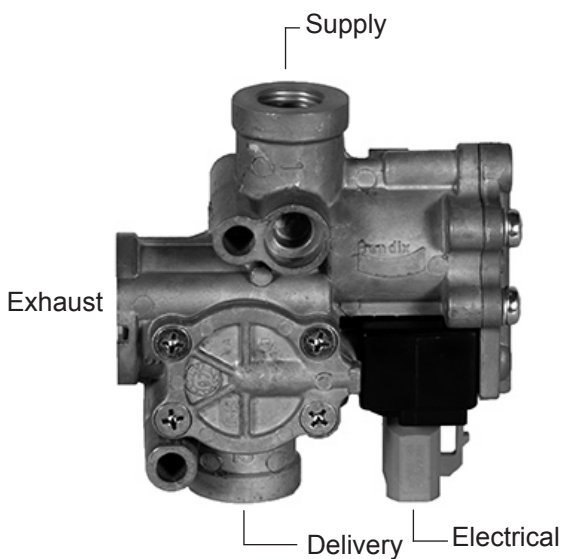

Modulator Valve	Voltage	Notes
FS065337X	12 V	1/2" NPT Fittings
Packard Electrical Connector		

Section 5 .Système de freins ABS
 .Anti-Lock Brake System

Modulateur ABS
ABS Modulator Valve

M-32

Modulator Valve	Voltage	Notes
FS801665X	12 V	1/2" NPT Fittings
Twist-Lock Electrical Connector		

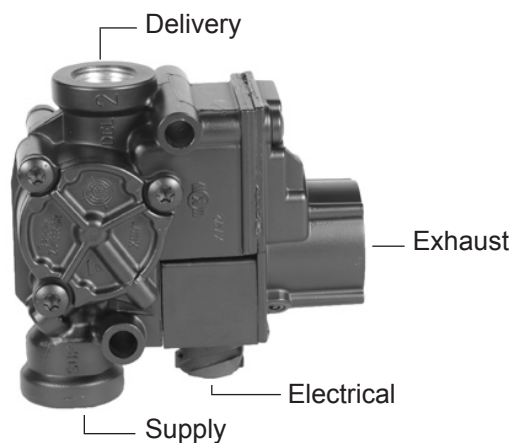

Modulateurs ABS
ABS Modulator Valves

M-32QR

Modulator Valve	Voltage	Notes
FS801479X	12 V	1/2" P-T-C fittings
FS801481X	12 V	1/2" NPT Fittings
Packard Electrical Connector		

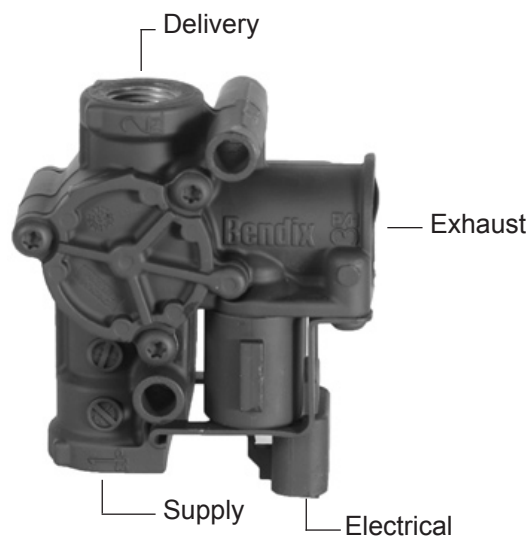

Section 5 .Système de freins ABS .Anti-Lock Brake System

Valves FFABS (priorité du frein de service) - 4 orifices d'alimentation FFABS Valves (Service Brake Priority) - 4 Delivery

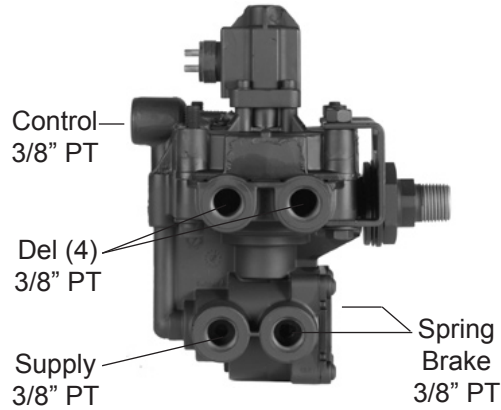

FFABS Valve	Voltage	Notes
AL430611X	12 V	1/2" Nipple Replaces: N4306CC
AL430614X	12 V	3/4" Nipple Replaces: N4306CD

Section 5 . Système de freins ABS . Anti-Lock Brake System

Valves relais ABS ABS Relay Valves

AL364040X
 shown here

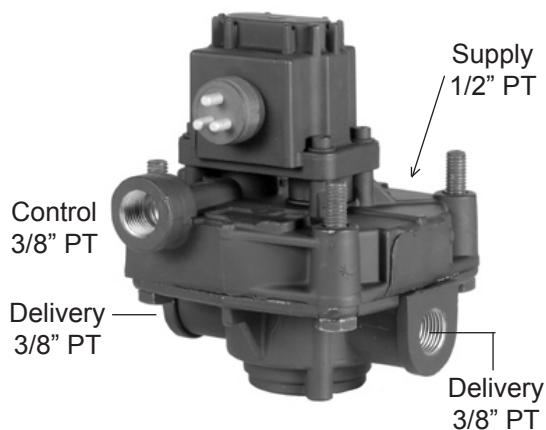

2 Delivery

Relay Valve	Voltage	Notes
AL364040X	12 V	1/2" Reservoir Mount * Replaces: 364140112
AL364045X	12 V	1/2" Frame Mount * Replaces: 364140111
For single axle applications, either 2S/1M or 4S/2M		

6 Delivery

Relay Valve	Voltage	Notes
AL364041X	12 V	1/2" Reservoir Mount * Replaces: 364141112
For multiple axle applications (2S/1M) and 3 or more axles (4S/2M)		

* Reservoir
 Mount

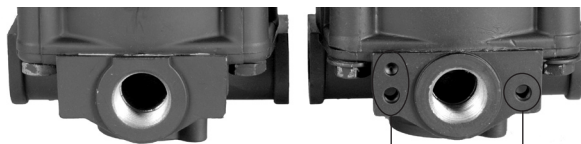

* Frame
 Mount

Propriété exclusive de FleetSpec. Toute reproduction interdite. / Exclusive property of FleetSpec. Reproduction prohibited.

Section 5 . Système de freins ABS . Anti-Lock Brake System

Assemblages de soupape ABS de tracteur (essieu arrière) Tractor ABS Valve Packages (Rear Axle)

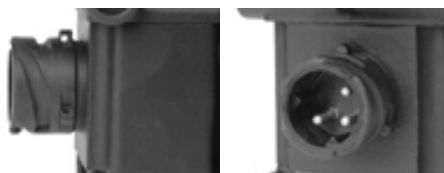
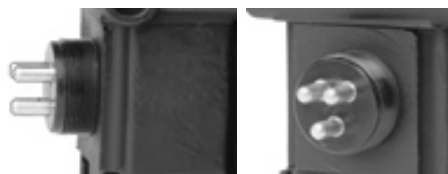
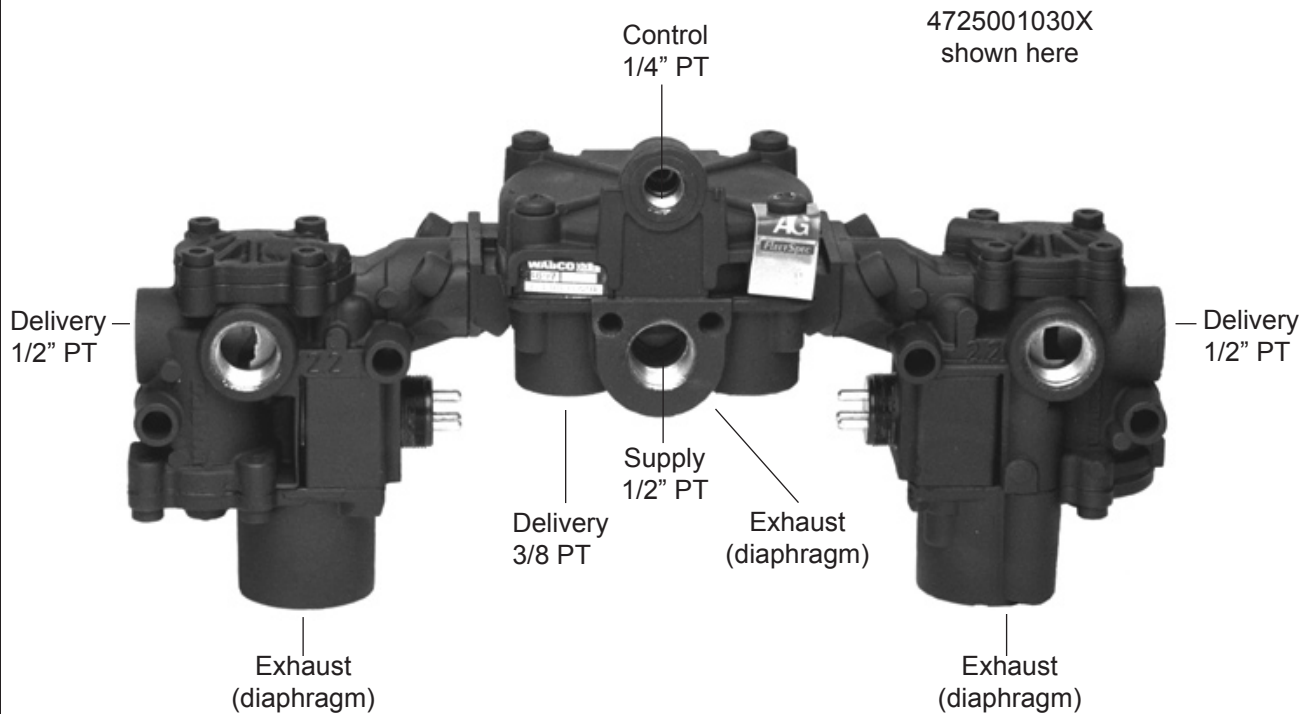

Section 5 .Système de freins ABS .Anti-Lock Brake System

Assemblages de soupape ABS de tracteur (essieu arrière) Tractor ABS Valve Packages (Rear Axle)

Complete Ass'y	Left side Modulator	Center Relay Valve	Right side Modulator	Crack PSI & Voltage	Conn. style	Configuration
4725001000X	4721950800X	9730110210X	4721950810X	4.0 PSI, 12 V	K	4S/4M Rear ports
4725001010X	4721950800X	9730110220X	4721950810X	5.5 PSI, 12 V	K	4S/4M Rear ports
4725001020X	4721950820X	9730110210X	4721950830X	4.0 PSI, 12 V	K	4S/4M, 6S/6M
4725001030X	4721950820X	9730110220X	4721950830X	5.5 PSI, 12 V	K	4S/4M, 6S/6M
4725001200X	4721950760X	9730110210X	4721950770X	4.0 PSI, 12 V	B	4S/4M
4725001210X	4721950760X	9730110220X	4721950770X	5.5 PSI, 12 V	B	4S/4M
4725001220X	4721950780X	9730110210X	4721950790X	4.0 PSI, 12 V	B	4S/4M, 6S/4M
4725001230X	4721950780X	9730110220X	4721950790X	5.5 PSI, 12 V	B	4S/4M, 6S/4M
4725001240X	4721950760X	9730110230X	4721950770X	4.0 PSI, 12 V	B	6S/4M plus 1M, 6S/6M
4725001250X	4721950760X	9730110240X	4721950770X	5.5 PSI, 12 V	B	6S/6M
4725001320X	4721950740X	9730110210X	4721950750X	4.0 PSI, 24 V	B	4S/4M, 6S/4M
4725004030X	4721950820X	9730110220X	4721950830X	5.5 PSI, 12 V	K	4S/4M, 6S/4M Rear ports
4725004050X	4721950820X	9730110240X	4721950830X	5.5 PSI, 12 V	K	4S/4M, 6S/4M Rear ports
4725004200X	4721950760X	9730110210X	4721950770X	4.0 PSI, 12 V	B	4S/4M Rear ports
4725004210X	4721950760X	9730110220X	4721950770X	5.5 PSI, 12 V	B	4S/4M Rear ports
4725004220X	4721950780X	9730110210X	4721950790X	4.0 PSI, 12 V	B	4S/4M, 6S/4M Rear ports
4725004230X	4721950780X	9730110220X	4721950790X	5.5 PSI, 12 V	B	4S/4M, 6S/4M Rear ports
4725004240X	4721950760X	9730110230X	4721950770X	4.0 PSI, 12 V	B	6S/4M plus 1M, 6S/6M Rear ports
4725004250X	4721950780X	9730110240X	4721950790X	5.5 PSI, 12 V	B	6S/6M Rear ports

Note 1> Compatible with C-, D-, and E- version ECU's.

Note 2> All valves available as Reman only.

Section 5 . Système de freins ABS . Anti-Lock Brake System

Assemblages de soupape ABS/ATC de tracteur (essieu arrière) Tractor ABS/ATC Valve Packages (Rear Axle)

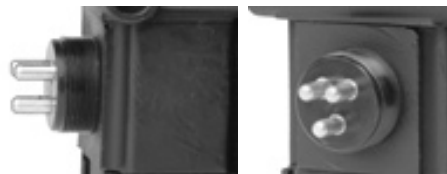
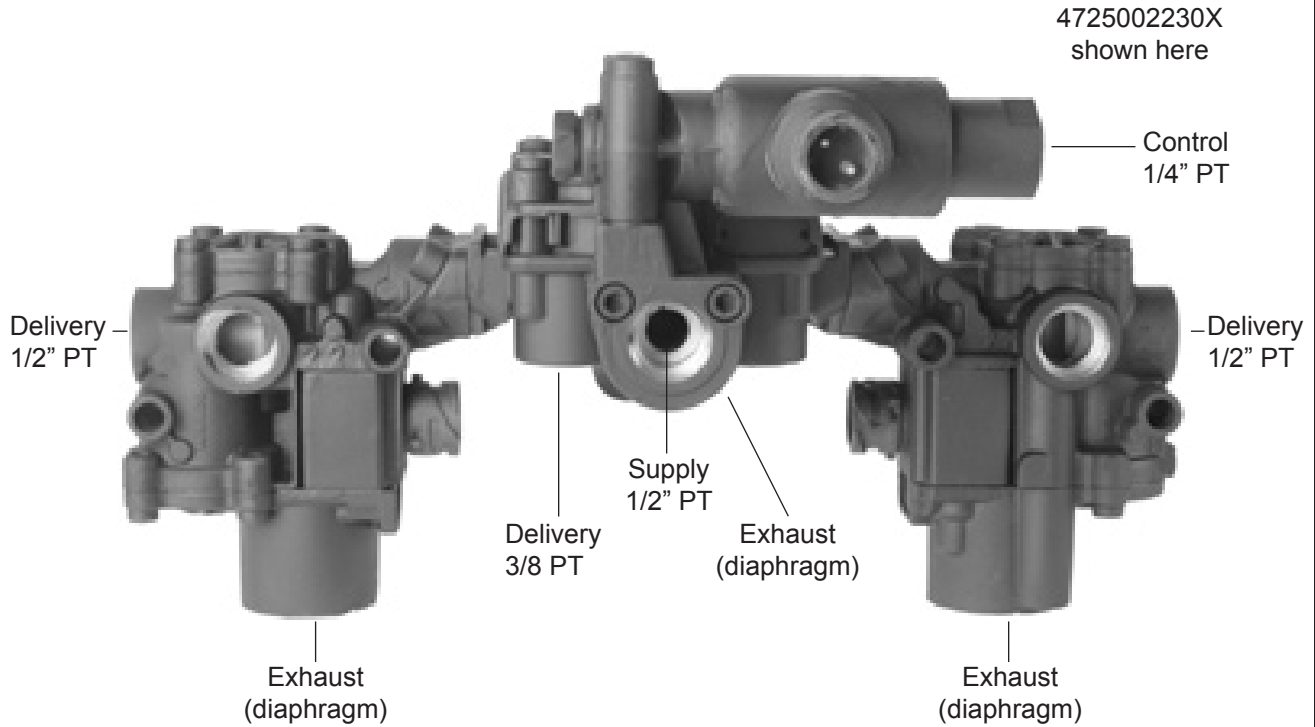

Kostal-Style Connector

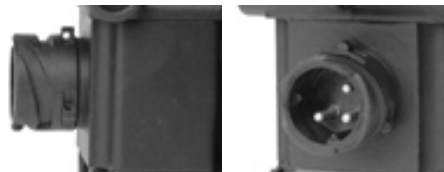

Bayonet-Style Connector

Section 5 .Système de freins ABS .Anti-Lock Brake System

Assemblages de soupape ABS/ATC de tracteur (essieu arrière) Tractor ABS/ATC Valve Packages (Rear Axle)

Complete Ass'y	Left side Modulator	Center Valves	Right side Modulator	Crack PSI & Voltage	Conn. style	Configuration
4725002030X	4721950820X	* 4721707910X ** 9730110260X	4721950830X	5.5 PSI, 12V	K	4S/4M, 6S/4M
4725002200X	4721950760X	* 4721707970X ** 9730110250X	4721950770X	4.0 PSI, 12V	B	4S/4M
4725002210X	4721950760X	* 4721707970X ** 9730110260X	4721950770X	5.5 PSI, 12V	B	4S/4M
4725002220X	4721950780X	* 4721707970X ** 9730110250X	4721950790X	4.0 PSI, 12V	B	4S/4M, 6S/4M
4725002230X	4721950780X	* 4721707970X ** 9730110260X	4721950790X	5.5 PSI, 12V	B	4S/4M, 6S/4M
4725002240X	4721950760X	* 4721707970X ** 9730110270X	4721950770X	4.0 PSI, 12V	B	6S/4M plus 1M 6S/6M
4725002250X	4721950760X	* 4721707970X **9730110280X	4721950770X	5.5 PSI, 12V	B	6S/4M plus 1M 6S/6M
4725002260X	4721950780X	* 4721707970X ** 9730110280X	4721950790X	5.5 PSI, 12V	B	4S/4M, 6S/4M
4725002320X	4721950740X	* 4721707960X ** 9730110250X	4721950750X	4.0 PSI, 24V	B	4S/4M, 6S/4M
4725005200X	4721950760X	* 4721707970X ** 9730110250X	4721950770X	4.0 PSI, 12V	B	4S/4M Rear ports
4725005210X	4721950760X	* 4721707970X **9730110260X	4721950770X	5.5 PSI, 12V	B	4S/4M Rear ports
4725005220X	4721950780X	* 4721707970X **9730110250X	4721950790X	4.0 PSI, 12V	B	4S/4M, 6S/4M Rear ports
4725005230X	4721950780X	* 4721707970X ** 9730110260X	4721950790X	5.5 PSI, 12V	B	4S/4M, 6S/4M Rear ports
4725005240X	4721950760X	* 4721707970X **9730110270X	4721950770X	4.0 PSI, 12V	B	4S/4M plus 1M, 6S/4M Rear ports
4725005250X	4721950780X	* 4721707970X ** 9730110280X	4721950790X	5.5 PSI, 12V	B	6S/4M Rear ports

Note 1> Complete Ass'y number is with the ATC valve.
 Note 2> Center Valves column: * is the ATC Valve, ** is the Relay Valve.
 Note 3> Compatible with D- and E- version ECU's only.
 Note 4> All valves available as Reman only.

Section 5 . Système de freins ABS . Anti-Lock Brake System

Assemblages de soupape ABS de tracteur (essieu avant) Tractor ABS Valve Packages (Front Axle)

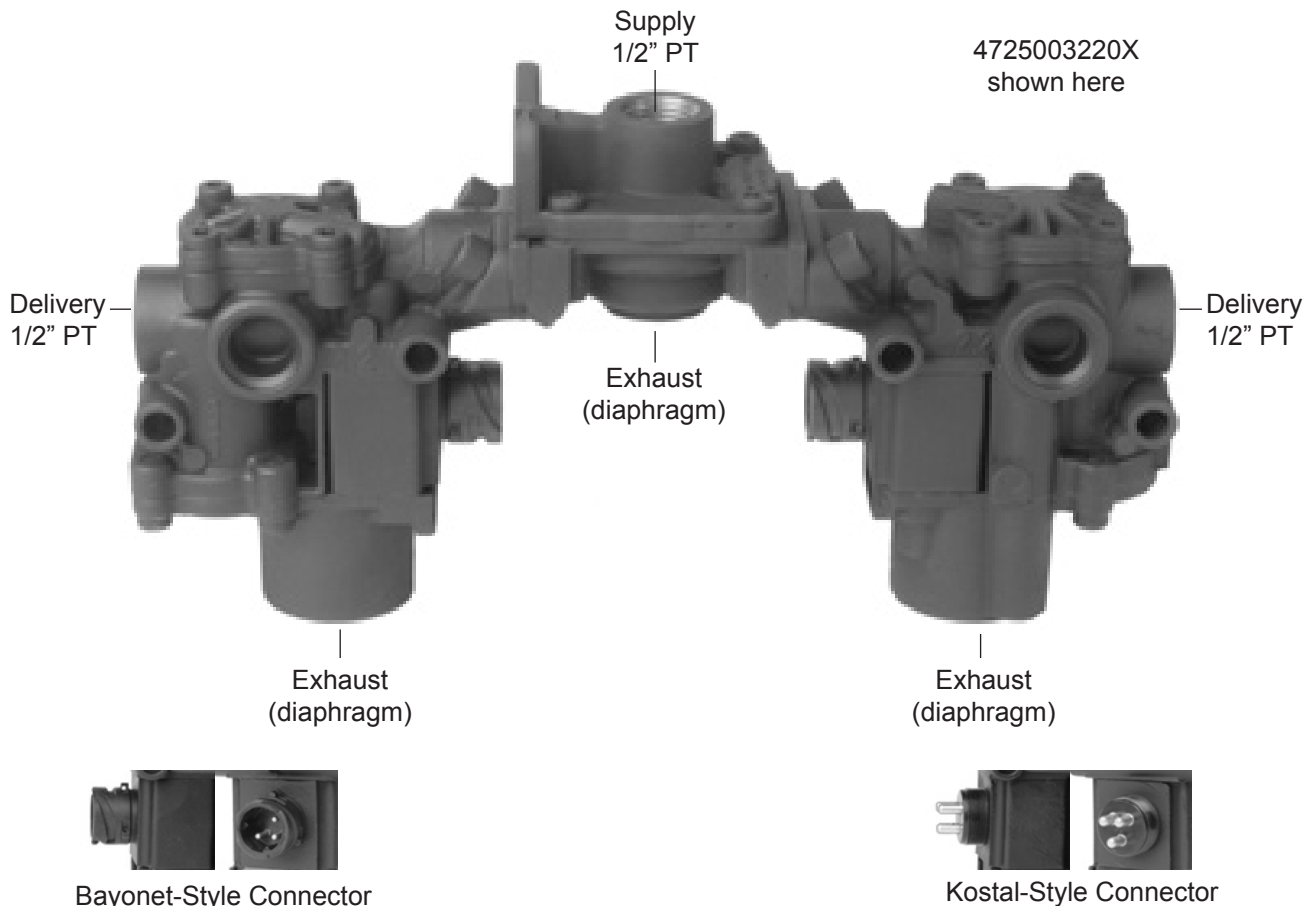

Complete Ass'y	Left side Modulator	Center Quick Release Valve	Right side Modulator	Crack PSI & Voltage	Conn. style	Configuration
4725003000X	4721950800X	9735001040X	4721950810X	1.0 PSI, 12 V	K	—
4725003010X	4721950800X	9735001050X	4721950810X	3.0 - 4.0 PSI 12 V	K	—
4725003020X	4721950800X	9735001060X	4721950810X	6.0 - 8.0 PSI 12 V	K	—
4725003200X	4721950760X	9735001040X	4721950770X	1.0 PSI, 12 V	B	—
4725003210X	4721950760X	9735001050X	4721950770X	3.0 - 4.0 PSI 12 V	B	—
4725003220X	4721950760X	9735001060X	4721950770X	6.0 - 8.0 PSI 12 V	B	—

Note 1> Compatible with C-, D-, and E- version ECU's.

Note 2> All valves available as Reman only.

Section 5 .Système de freins ABS .Anti-Lock Brake System

Modulateurs ABS de tracteur Tractor ABS Modulator Valves

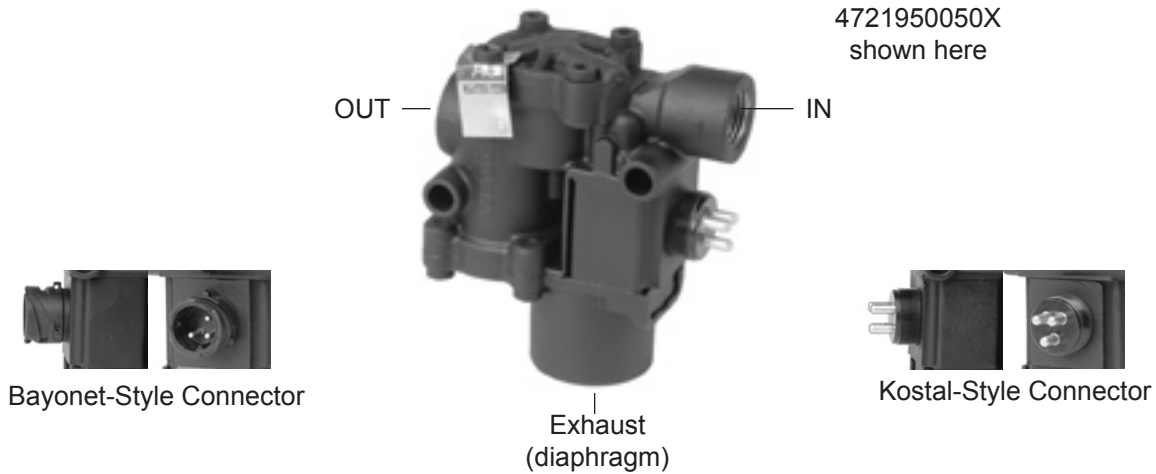

Modulator Valve	Port Size	Voltage	Conn. style	Notes
4008500530X	1/2 " NPT	12 V	B	
4008500540X	1/2 " NPT	12 V	B	
4721950040X	M22 x 1.5	24 V	K	Repl. Meritor R955334
4721950050X	1/2 " NPT	12 V	K	
4721950100X	M22 x 1.5	24 V	K	
4721950170X	1/2 " NPT	12 V	K	
4721950180X	M22 x 1.5	24 V	B	
4721950520X	1/2 " NPT	12 V	B	
4721950670X	1/2 " NPT	12 V	B*	*Push-to-Connect Weatherhead
4721950740X	1/2 " NPT	24 V	B	
4721950750X	1/2 " NPT	24 V	B	
4721950840X	1/2 " NPT	24 V	K	
4721950850X	1/2 " NPT	24 V	K	
4721950920X	1/2 " NPT	12 V	K	
4721950930X	1/2 " NPT	12 V	K	
4721950940X	1/2 " NPT	12 V	B	
4721950950X	1/2 " NPT	12 V	B	
4721950960X	1/2 " NPT	24 V	B	
Note 1> Compatible with all versions of Meritor / Wabco ECU's. Note 2> All valves available as Reman only.				

Section 5 . Système de freins ABS . Anti-Lock Brake System

Assemblages ECU/modulateur simple de remorque Trailer ECU/Single Modulator Valve Assemblies

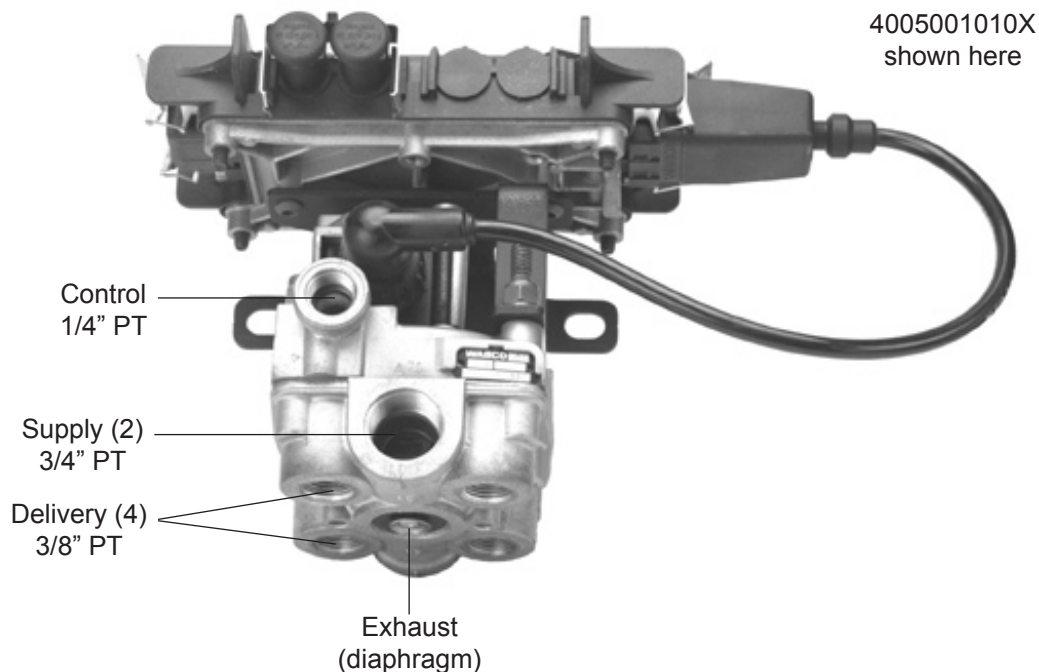

Complete Ass'y	Replacement Modulator	Configuration	Notes
4005001010X	4721950330X	2S/1M	Recommended for use with standard Trailers
4005001040X	4721950330X	2S/1M	Recommended for use with Turntables, Steerables, and Dollies
Note > All valves available as Reman only.			

Section 5 .Système de freins ABS .Anti-Lock Brake System

Assemblages ECU/modulateur double de remorque Trailer ECU/Dual Modulator Valve Assemblies

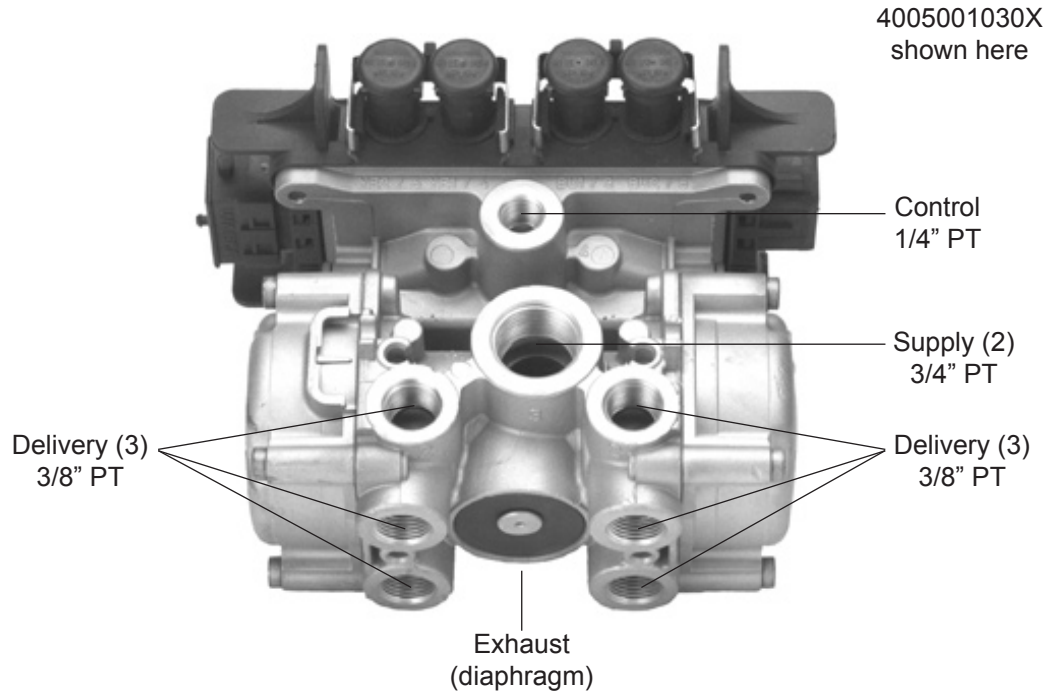

Complete Ass'y	Replacement Modulator	Configuration	Notes
4005001020X	4008506020X	2S/2M	Standard, for Trailers Replaces Meritor R955320
4005001030X	4008506020X	2S/2M, 4S/2M, 4S/3M	Premium, for Trailers Replaces Meritor R955321
4005001050X	4008506020X	2S/2M, 4S/2M, 4S/3M	Premium (with InfoLink capability), for Trailers
Note > All valves available as Reman only.			

Section 5 . Système de freins ABS . Anti-Lock Brake System

Assemblages ECU/modulateur de remorque Trailer ECU/Modulator Valve Assemblies

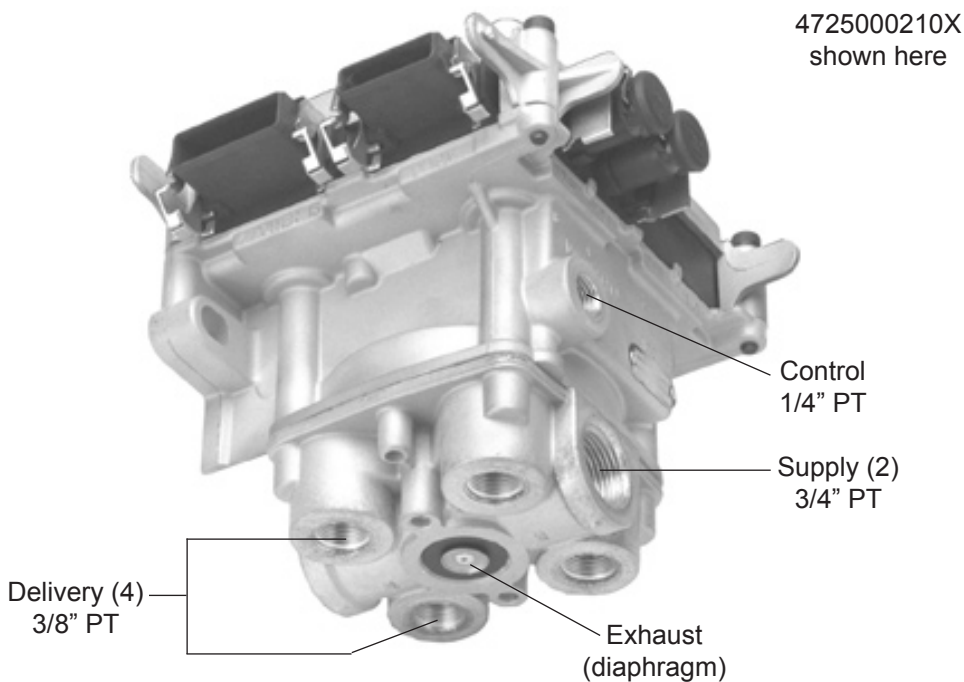

4725000210X
shown here

Complete Ass'y	Configuration	Notes
4725000110X	2S/1M	Turntables, Steerables, and Dollies (NO indicator light on cover)
4725000210X	2S/1M	"Standard" Trailer (WITH indicator light on cover) Replaces: Meritor R955344
Note > All valves available as Reman only.		

Section 5 .Système de freins ABS .Anti-Lock Brake System

Assemblages ECU/modulateur de remorque Trailer ECU/Modulator Valve Assemblies

4725000120X
 shown here

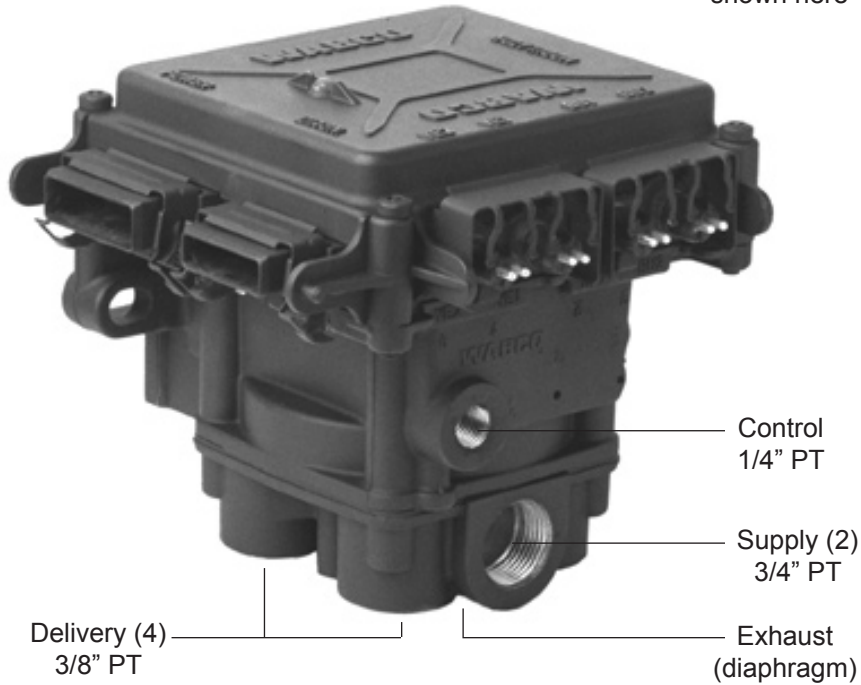

Complete Ass'y	Configuration	Notes
4725000120X	2S/2M, 4S/2M	Replaces: Meritor R955320
4725000130X	4S/3M	
Note > All valves available as Reman only.		

Section 5 .Système de freins ABS
.Anti-Lock Brake System

Modulateur ABS de remorque - 2 orifices d'alimentation
Trailer ABS Modulator Valve - 2 Delivery

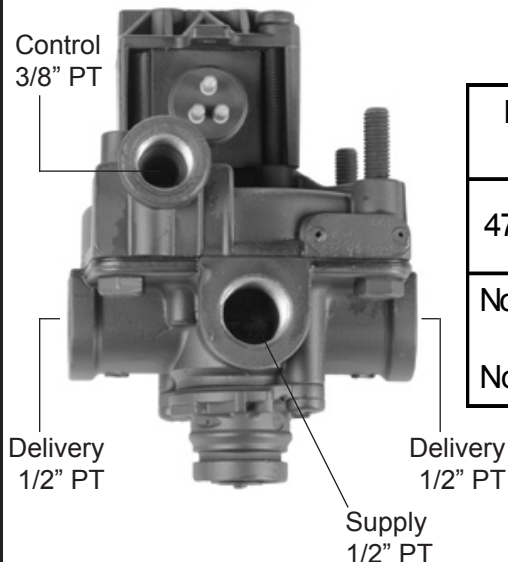

Modulator Valve	Crack PSI & Voltage	Conn. style	Notes
4721950230X	3.0 - 4.0 PSI 12 Volts	K	Trailers produced Before 04-01-99
Note 1> For 3M Enhanced Easy-Stop or 2M/3M Easy-Stop Units. Note 2> Valve available as Reman only.			



Modulateurs ABS de remorque - 4 orifices d'alimentation
Trailer ABS Modulator Valves - 4 Delivery

4721950330X shown here

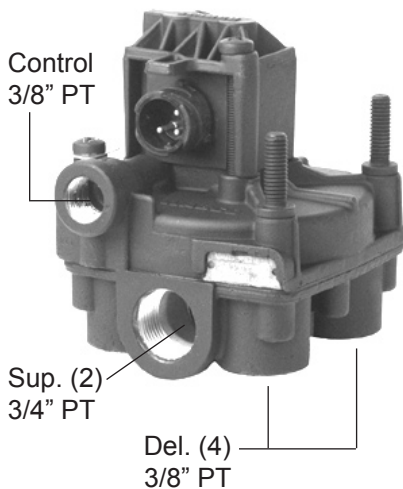

Modulator Valve	Crack PSI & Voltage	Conn. style	Notes
4721950260X	3.0 - 4.0 PSI 12 Volts	K	Trailers produced Before 04-01-99
4721950270X			
4721950320X			
4721950330X		B	Trailers produced from 04-01-99 and later
Note 1> For 3M Enhanced Easy-Stop or 2M/3M Easy-Stop Units. Note 2> All valves available as Reman only.			



Section 6

Soupapes de suspension à air
Suspension Air Valves

Section 6 • Soupapes de suspension à air
 • Suspension Air Valves

Soupapes de contrôle de niveau
Height Control Valves

New	Notes
FS-6586NT	* Metal construction. * Immediate Response. * Left or Right side installation.
Replaces: Neway 90554241	

New	Notes
FS-6843	* Engineered Plastic construction. * Immediate Response. * Left or Right side installation.
Replaces: Haldex 90555105	

New	Notes
FS-6586NTA	* Immediate Response. * Left or Right side installation. * FS-6678 Linkage Kit included.

New	Notes
FS-6587	* Immediate Response. * Left or Right side installation. * FS-6590 Dump Valve included. * Normally Open - needs air to dump.
Replaces: Neway 90554271	

New	Notes
FS-6590	* Dump Valve <only> for FS-6587. * Normally Open - needs air to dump.

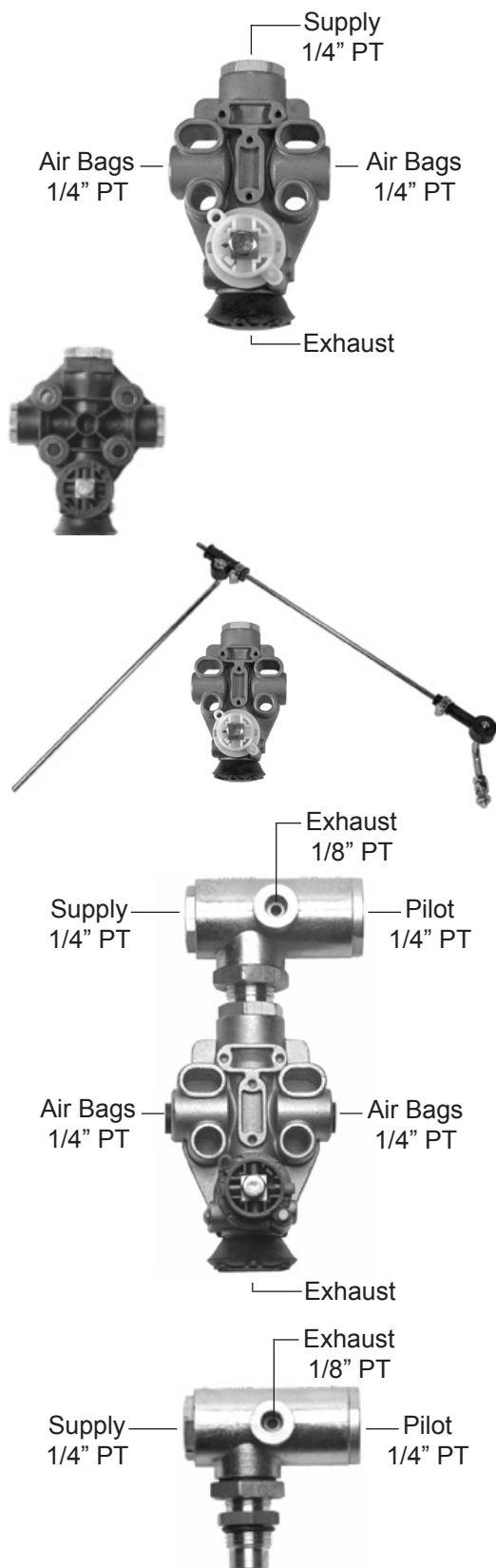

Section 6 . Soupapes de suspension à air Suspension Air Valves

Soupapes de contrôle de niveau Height Control Valves

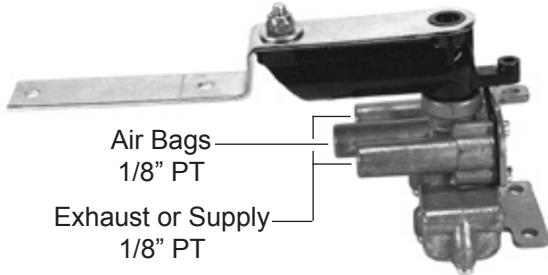

New	Notes
FS-6586	* Left or Right side installation. * Less responsive to short duration axle position changes.
Replaces: Neway 90054007	

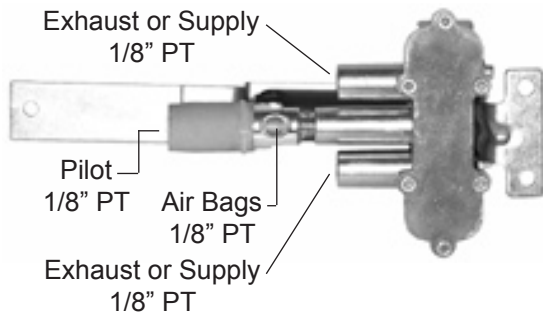

New	Notes
FS-6589NO	* Delayed Response. * Left or Right side installation. * Unresponsive to short duration axle position changes. * FS-6588NO Dump Valve included * Normally Open - needs air to dump.
Replaces: Neway 90554334	

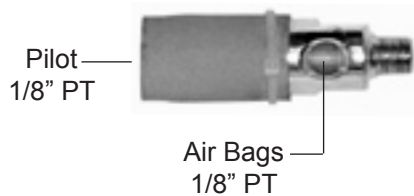

New	Notes
FS-6588NO	* Dump Valve <only> for FS-6589NO * Normally Open - needs air to dump.
Replaces: Neway 90554335	

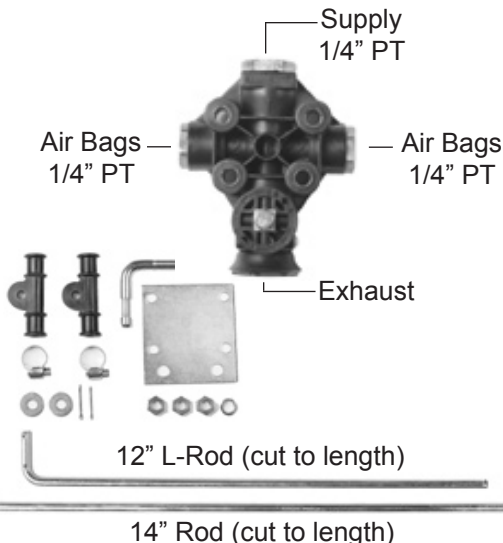

New	Notes
FSKN27000N	* Immediate Response. * Left or Right side installation. * Made of Engineered Plastic * Linkage Kit included. * Mounting Adapter Plate included
Replaces: Haldex KN27000	

Propriété exclusive de FleetSpec. Toute reproduction interdite. / Exclusive property of FleetSpec. Reproduction prohibited.

Section 6 • Soupapes de suspension à air
 • Suspension Air Valves

**Soupapes de contrôle de niveau
 Height Control Valves**

New	Notes
FS-6585	* Fast Response, High Airflow design * 4 (1/4" PT) Ports.
Replaces: Hendrickson Trailer VS-227, A-28651 Barksdale 52321-Q195	

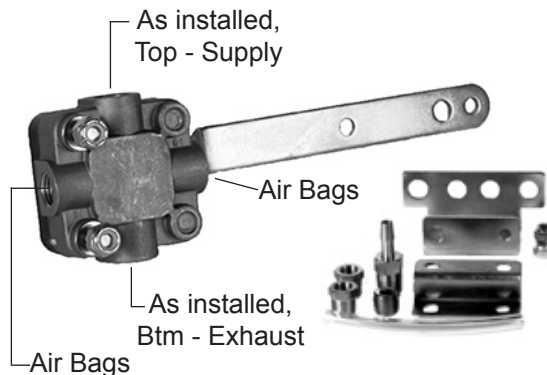
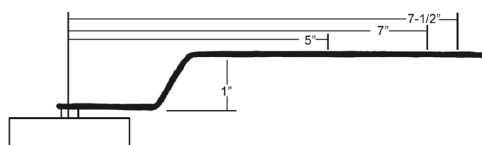

New	Notes
FS-6603	* Fast Response, High Airflow design * 4 (1/4" PT) Ports.
Replaces: Barksdale 52321-Q29, Q113, Q197 Freightliner KD-2204	

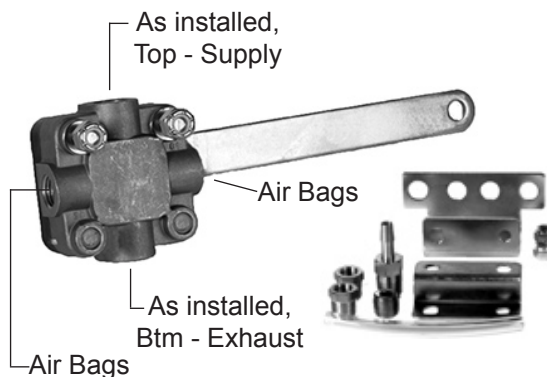
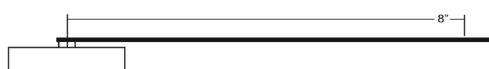

New	Notes
FS-6613	* Fast Response, High Airflow design * 4 (1/4" PT) Ports.
Replaces: Barksdale KD-2375, 52321-Q303 Hadley H00450CE	

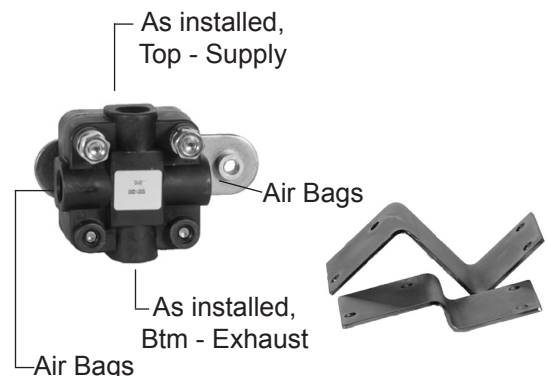
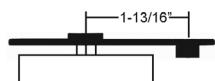

Section 6 . Soupapes de suspension à air Suspension Air Valves

Soupapes de contrôle de niveau Height Control Valves

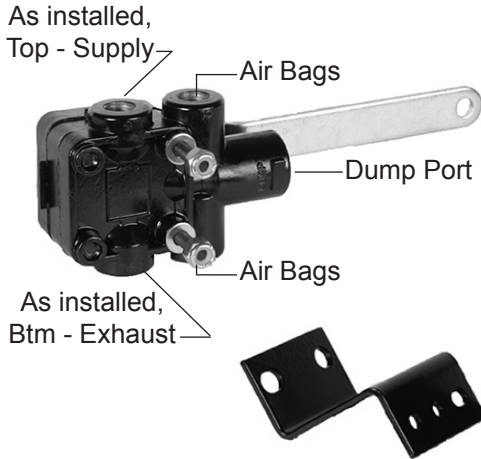

New	Notes
FS-6591	* Fast Response, High Airflow design * Integral Dump Valve. (N.C.) * 5 (1/4" PT) Ports.
Replaces: Hendrickson 57977-000, 60501-000 Barksdale 52341-Q123, KD2265 KD2315 Euclid E-11870	

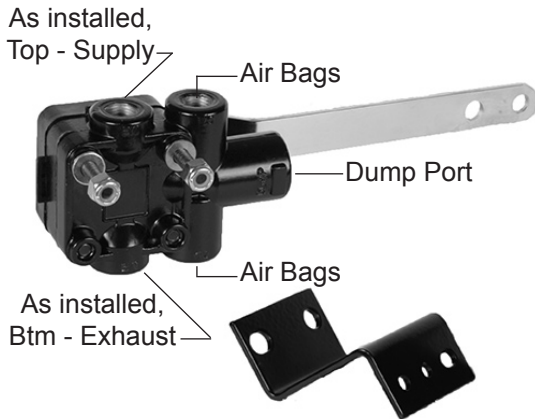
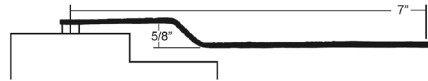

New	Notes
FS-6592	* Fast Response, High Airflow design * Integral Dump Valve. (N.C.) * 5 (1/4" PT) Ports.
Replaces: Barksdale KD2205, Volvo 3188710 Freightliner 16-14318-000	

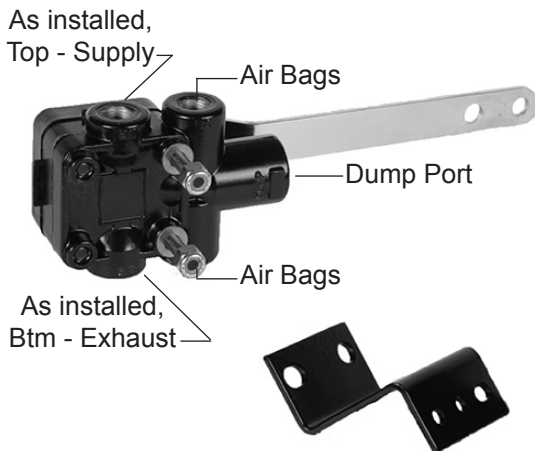

New	Notes
FS-6614	* Fast Response, High Airflow design * Integrated Dump Port (NC) * 5 (1/4" PT) Ports.
Replaces: Barksdale KD2228 Peterbilt 08-03315	



Section 6 : Soupapes de suspension à air
 : Suspension Air Valves

**Soupapes de contrôle de niveau
 Height Control Valves**

New	Notes
FS-6600	* Fast Response, High Airflow design * Integral Dump Valve. (N.C.) * 5 (1/4" PT) Ports.
Replaces: Peerless Trailer 52341-Q115	

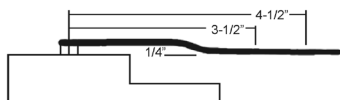

New	Notes
FS-6602	* Fast Response, High Airflow design * Integral Dump Valve. (N.O. - needs air applied to operate levelling) * Works with Trailer Parking Brakes. * 5 (1/4" PT) Ports.
Replaces: Hendrickson Trailer VS-228, A-29391	

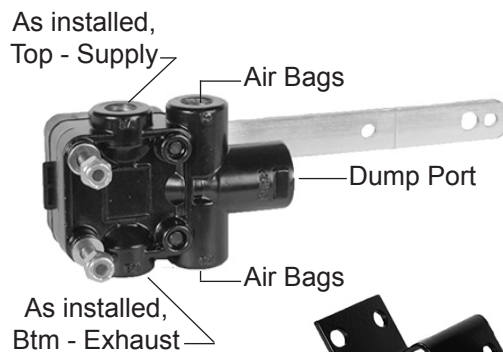
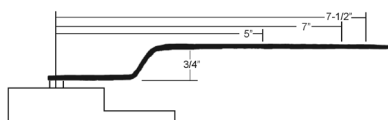

New	Notes
FS-6610	* Fast Response, High Airflow design * Integral Dump Valve. (N.C.) * 5 (1/4" PT) Ports.
Replaces: Barksdale KD-2360, 52341-Q206 Hadley HAD500NS International 2506169C91	

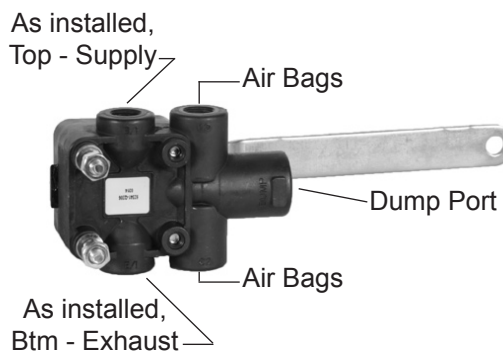
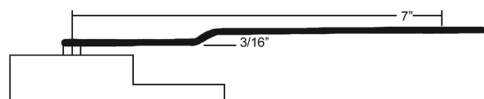

Section 6 : Soupapes de suspension à air
: Suspension Air Valves

Soupapes de contrôle de niveau
Height Control Valves

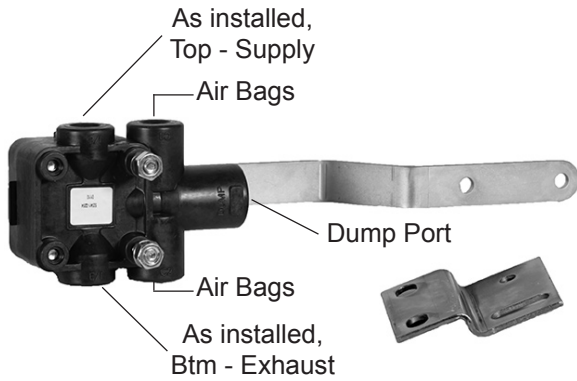

New	Notes
FS-6611	* Fast Response, High Airflow design * Integral Dump Valve. (N.C.) * 5 (1/4" PT) Ports.
Replaces: Barksdale KD-2358, 52341-Q204 Hadley H00500RS	

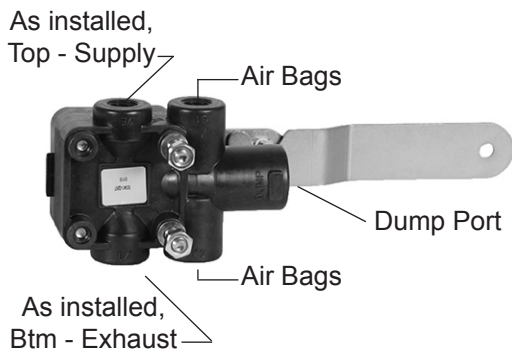
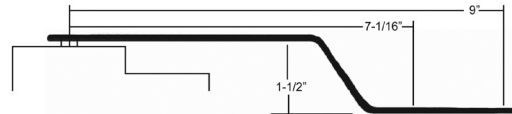

New	Notes
FS-6612	* Fast Response, High Airflow design * Integral Dump Valve. (N.C.) * 5 (1/4" PT) Ports.
Replaces: Barksdale: KD-2374, KD-2445, 52341-Q207 Haldex: G90-10199-095, G90-10919-99, PR 90554950, 90554945	

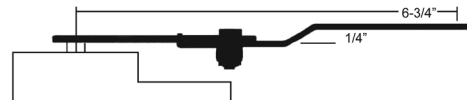

New	Notes
FS-H00450CE	* 2 Install brackets and 2 arms covers a variety of installations.
Replaces: Euclid E-9623, Hadley H00450CE, Tectran 80-1006. Volvo 3130560	



Section 6 . Soupapes de suspension à air . Suspension Air Valves

Tiges pour les soupapes de contrôle de niveau Linkages for Height Control Valves

New	Notes
FS-6594	* 18" Straight Rod. * Easily cuts down for any install.
Replaces: Neway SRK168, 48100225	
FS-6594R	"Lollipop" rubber link <only>
Replaces: Haldex 90054516	

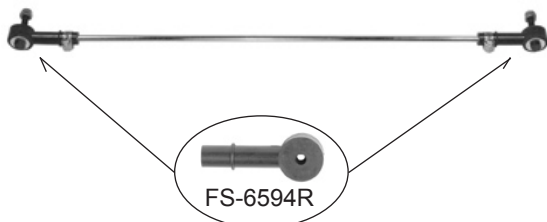

New	Notes
FS-6595	* Maximum 21" C to C * Easily adjusts for any install.
Replaces: Hendrickson/Turner A14187 Hendrickson S-14187	



New	Notes
FS-6678	* 14-1/2" Straight Rod. * 12-1/2" L Rod. * Easily adjusts for any install.
Replaces: Neway SRK205, 48100867	
FS-6678RE	"Elbow" rubber link <only>
Replaces: Haldex 90054630	
FS-6678R	"Lollipop" rubber link <only>
Replaces: Haldex 90054670	

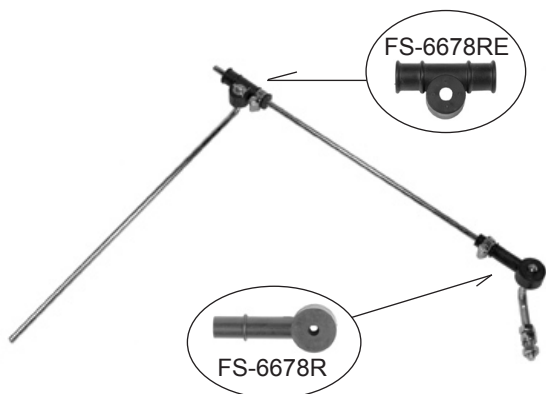

New	Notes
FS-6598	* Replacement kit for Haldex KN27000 Height Control Valve * Easily adjusts for any install.

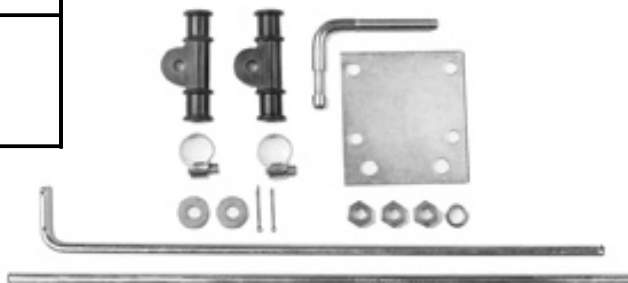

Section 6 • Soupapes de suspension à air • Suspension Air Valves

Soupapes de contrôle Control Valves

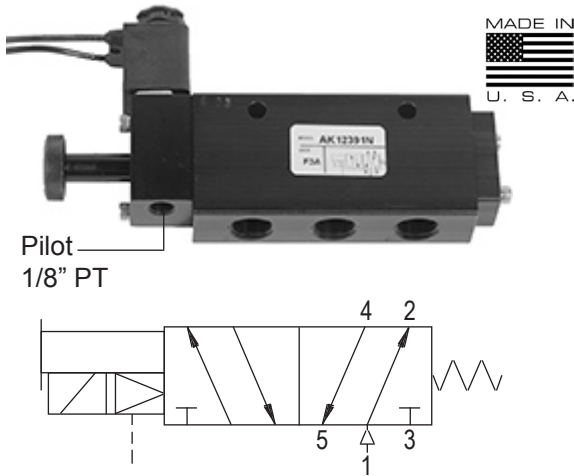

New	Notes
AK12391N	<ul style="list-style-type: none"> * 2 Position, 5 (3/8" PT) Port Valve. * 12 Volt Solenoid, Spring Return. * Manual (locking) Override. * 96 SCFM airflow (at full open). * External Pilot supply needed. * 40 PSI to 150 PSI Supply.
Replaces: Manac SP-4904 Ride-Air RA220-1	

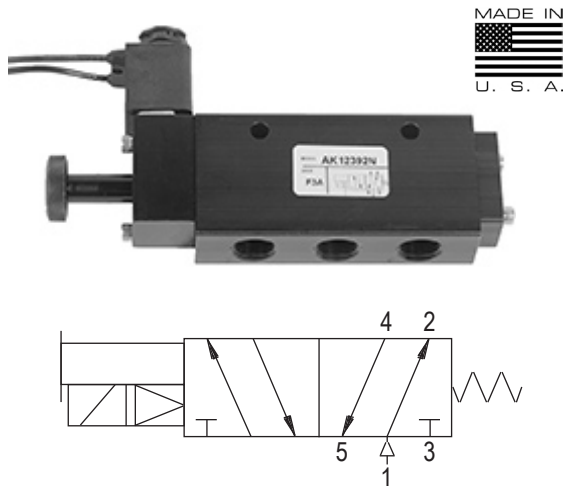

New	Notes
AK12392N	<ul style="list-style-type: none"> * 2 Position, 5 (3/8" PT) Port Valve. * 12 Volt Solenoid, Spring Return. * Manual (locking) Override. * 96 SCFM airflow (at full open). * Mesh screens in ports 1, 2 and 4. * 40 PSI to 150 PSI Supply.
Replaces: HD Plus ACW4944 Manac SP-4900, 223-6197 Ride-Air RA220	

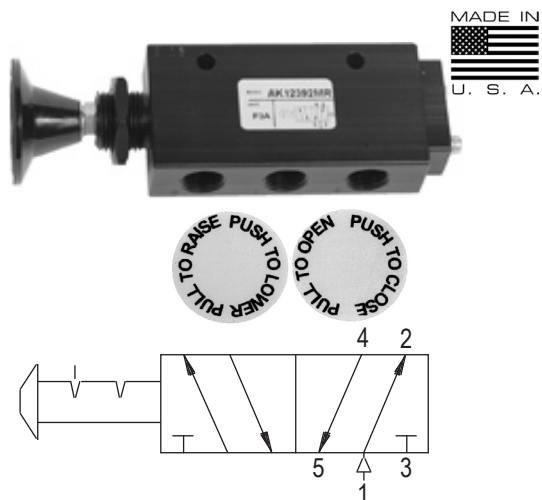

New	Notes
AK12392MR	<ul style="list-style-type: none"> * 2 Position, 5 (3/8" PT) Port Valve. * Fully Manual Operation. * 96 SCFM airflow (at full open). * Panel, inline, or thru hole mounting. * 200 PSI Max supply.
Replaces: Ride-Air RA221	

Section 6 : Soupapes de suspension à air
 : Suspension Air Valves

**Soupapes de contrôle
 Control Valves**

New	Notes
AK12392PR	<ul style="list-style-type: none"> * 2 Position, 5 (3/8" PT) Port Valve. * Manual operation, with air pilot reset. Detented in the out position. * 96 SCFM airflow (at full open). * Panel, inline, or thru hole mounting. * 200 PSI Max supply,. * 40 PSI Minimum for pilot pressure.
Replaces: Ride-Air RA222	

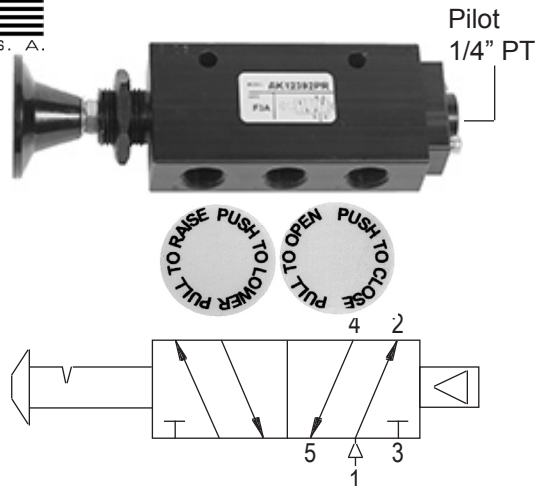

New	Notes
AK12393N	<ul style="list-style-type: none"> * 2 Position, 3 (3/8" PT) Port Valve. * Manual operation, with air pilot reset. Detented in the out position. * 96 SCFM airflow (at full open). * Panel, inline, or thru hole mounting. * 200 PSI Max supply,. * 40 PSI Minimum for pilot pressure.
Replaces: Manac 223-6204 Ride-Air RA222-3	

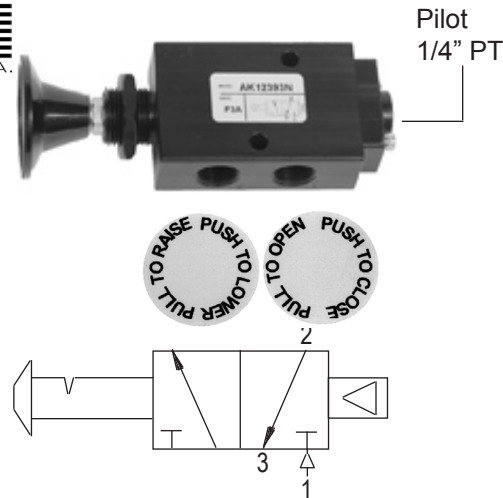

New	Notes
AK12394N	<ul style="list-style-type: none"> * 2 Position, 3 (3/8" PT) Port Valve. * Air pilot operation, Spring return. * 96 SCFM airflow (at full open). * Inline, or thru hole mounting. * 200 PSI Max supply,. * 40 PSI Minimum for pilot pressure.
Replaces: HD Plus ACW4948 Manac SP-4902, 223-6203, 223-6196 Ride-Air RA224-3	

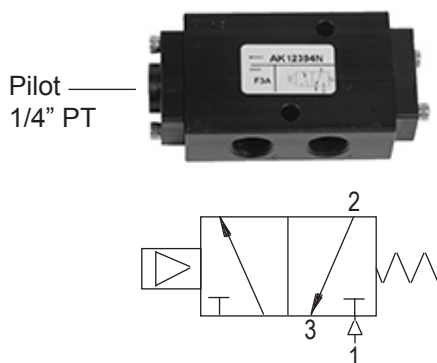

Section 6 • Soupapes de suspension à air • Suspension Air Valves

Soupapes de contrôle Control Valves

Pilot
1/4" PT



MADE IN
 U. S. A.

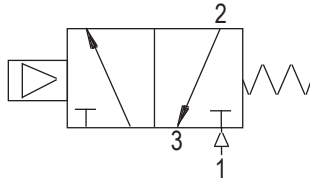

New	Notes
AK12394-1/4	<ul style="list-style-type: none"> * 2 Position, 3 (1/4" PT) Port Valve. * Air pilot operation, Spring return. * 48 SCFM airflow (at full open). * Inline, or thru hole mounting. * 200 PSI Max supply,. * 40 PSI Minimum for pilot pressure.
Replaces: Norgren K41DA00KS1KA-2	



MADE IN
 U. S. A.

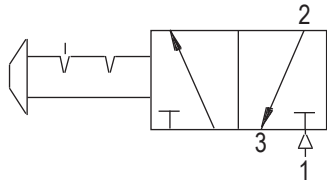
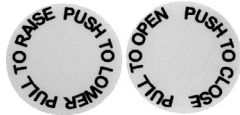

New	Notes
AK12395N	<ul style="list-style-type: none"> * 2 Position, 3 (3/8" PT) Port Valve. * Fully Manual Operation. * 96 SCFM airflow (at full open). * Panel, inline, or thru hole mounting. * 200 PSI Max supply.
Replaces: Ride-Air RA221-3	

Pilot
1/4" PT



MADE IN
 U. S. A.

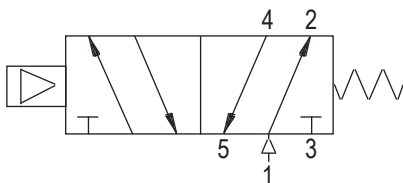

New	Notes
AK12396N	<ul style="list-style-type: none"> * 2 Position, 5 (3/8" PT) Port Valve. * Air pilot operation, Spring return. * 96 SCFM airflow (at full open). * Inline, or thru hole mounting. * 200 PSI Max supply,. * 40 PSI Minimum for pilot pressure.
Replaces: Ride-Air RA224	

Section 6 • Soupapes de suspension à air
 • Suspension Air Valves

**Soupapes de contrôle
 Control Valves**

New	Notes
AK12401N	<ul style="list-style-type: none"> * 2 Position, 3 (3/8" PT) Port Valve. * Manual operation, with air pilot reset. Detented in the out position. * 96 SCFM airflow (at full open). * Panel, inline, or thru hole mounting. * 200 PSI Max supply. * 40 PSI Minimum for pilot pressure. * Mini Black Knob.
Replaces: HD Plus ACW4946 Manac SP-4901, 223-6204	

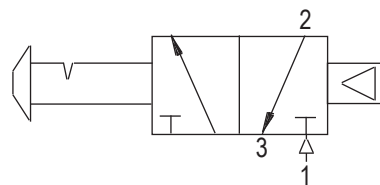

New	Notes
AK12402N	Air Control Valve, with Air Reset for use in FS-6967-6A Suspension Dump Control Box.

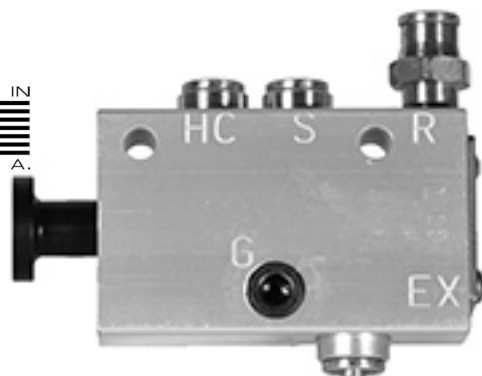

New	Notes
AK12403N	Air Control Valve (full manual), for use in FS-6967-6B Suspension Dump Control Box.



Section 6 . Soupapes de suspension à air Suspension Air Valves

Soupapes de contrôle Control Valves

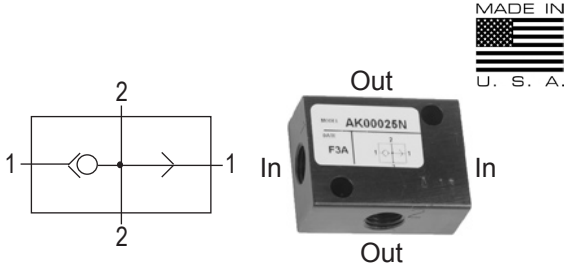

New	Notes
AK00025N	<ul style="list-style-type: none"> * 4 (1/4" PT) Ports * Thru hole mounting. * 10 to 150 PSI operation.
Replaces: Norgren T65A2800	

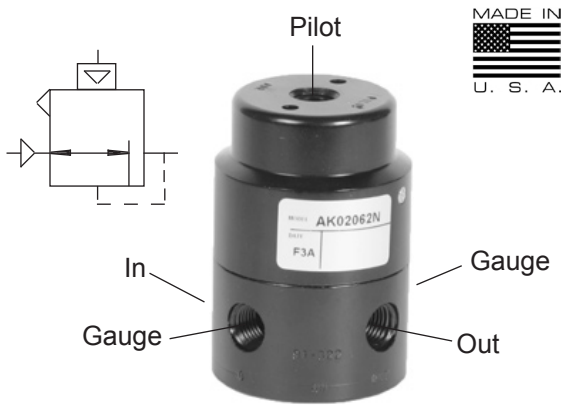

New	Notes
AK02062N	<ul style="list-style-type: none"> * 2:1 Ratio Regulator. * 5 (1/4" PT) Ports. - 2 for optional Air Gauge use. * Outputs 50 % of Signal Pressure. * Designed to regulate a Steer Axle with Torpress Air Bag.
Replaces: Ride-Air RA6210	



New	Notes
AK12392S	Replacement Solenoid Coil for AK12391N or AK12392N Valves
Replaces: Ride-Air RA220A	



New	Notes
AK12392SP	Replacement Spool for AK12391N or AK12392N Control Valves
Replaces: Ride-Air RA220C	

Section 6 : Soupapes de suspension à air
 : Suspension Air Valves

**Soupapes de contrôle
 Control Valves**

New	Notes
RA12391N	<ul style="list-style-type: none"> * 2 Position, 5 (3/8" PT) Port Valve. * 12 Volt Solenoid, Spring Return. * Manual (locking) Override. * Manual or Electric operation. * 1/8" Pilot Port * External pilot supply needed for electrical operation
Replaces: Ride-Air RA020-1	



New	Notes
RA12392N	<ul style="list-style-type: none"> * 2 Position, 5 (3/8" PT) Port Valve. * 12 Volt Solenoid, Spring Return. * Manual (locking) Override. * Manual or Electric operation. * Internal Pilot Supply
Replaces: Ride-Air RA020	

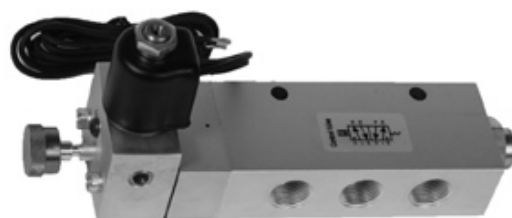

New	Notes
RA12392S	Replacement Solenoid Coil for RA12391N or RA12392N Valves
Replaces: Ride-Air RA020A	



New	Notes
RA12392SP	Replacement Spool Kit for RA12391N or RA12392N Valves
Replaces: Ride-Air RA020C	



Section 6 . Soupapes de suspension à air Suspension Air Valves

Soupapes de contrôle Control Valves



New	Notes
NG12391N	<ul style="list-style-type: none"> * 2 Position, 5 (3/8" PT) Port Valve. * 12 Volt Solenoid, Spring Return. * Manual (locking) Override. * Pilot air needed for electric operation * Solenoid on 3 port side of valve.
Replaces: Norgren K910019 Haldex 90554662 Tectran 29-SS6E	



New	Notes
NG12392N	<ul style="list-style-type: none"> * 2 Position, 5 (3/8" PT) Port Valve. * 12 Volt Solenoid, Spring Return. * Manual (locking) Override. * Solenoid on 2 port side of valve.
Replaces: Norgren K910014 Manac 023-299, 223-6197 Tectran 29-SS6M	

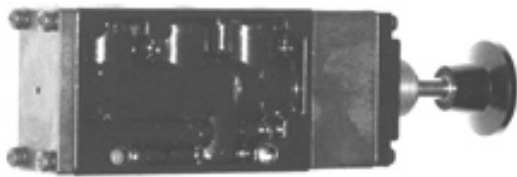

New	Notes
NG12392MR	<ul style="list-style-type: none"> * 2 Position, 5 (3/8" PT) Port Valve. * Fully Manual Operation.
Replaces: Parker 52043-1000	

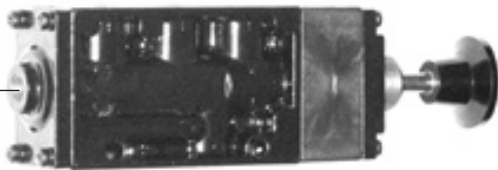

New	Notes
NG12392PR	<ul style="list-style-type: none"> * 2 Position, 5 (3/8" PT) Port Valve. * Manual Operation, Pilot Return.
Replaces: Parker 52045-1000	

Section 6 : Soupapes de suspension à air Suspension Air Valves

Soupapes de contrôle Control Valves

New	Notes
NG12392SR	* 2 Position, 5 (3/8" PT) Port Valve. * Manual Operation, Spring Return.
Replaces: Parker 52041-1000	



New	Notes
NG12393N	* 2 Position, 3 (3/8" PT) Port Valve. * Manual Operation, Pilot Return.
Replaces: Norgren K910054 Air-Max 02400188 Manac 223-6195	



Pilot
 1/8" PT

New	Notes
NG12394N	* 2 Position, 3 (3/8" PT) Port Valve. * Air Operated, Spring Return.
Replaces: Norgren K41EA00KS6KA2 Manac 023-2995, 223-6196	



Control
 1/8" PT

New	Notes
NG12395N	* 2 Position, 3 (3/8" PT) Port Valve. * Fully Manual Operation.
Replaces: Norgren K910038 Manac 023-2996 Parker M08531826	



Section 6 • Soupapes de suspension à air • Suspension Air Valves

Soupapes de contrôle Control Valves



Control
1/8" PT

New	Notes
NG12396N	* 2 Position, 5 (3/8" PT) Port Valve. * Air Operated, Spring Return.
Replaces: Norgren K71EA00KS6KA2 Manac 023-2997	

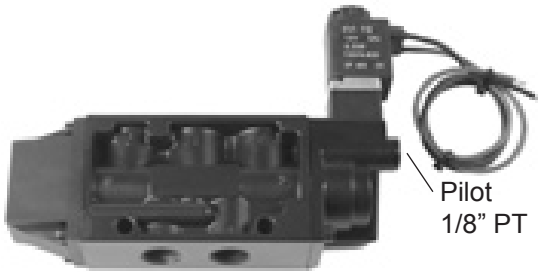

Pilot
1/8" PT

New	Notes
NG12398N	* 2 Position, 5 (3/8" PT) Port Valve. * 12 Volt Solenoid, Spring Return. * Pilot Port (35-150 PSI).
Replaces: Norgren K71EA00KS6KVV Velvac 320130	

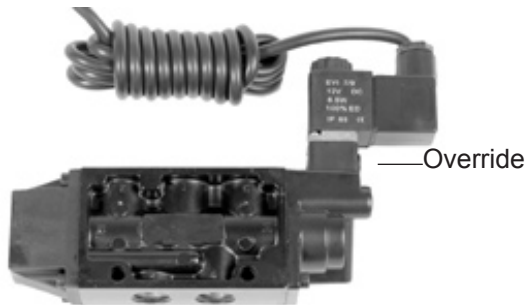

Override

New	Notes
NG12399N	* 2 Position, 5 (3/8" PT) Port Valve. * 12 Volt Solenoid, Spring Return.. * Locking Override Knob.
Replaces: Norgren K71EA00KS6KV2 Velvac 320131	



New	Notes
NG12410N	* 2 Position, 3 (3/8" PT) Port Valve. * 12 Volt Solenoid, Spring Return. * Normally Open, Quick Response
Replaces: Norgren K910027 Can replace FS-4523, when higher airflow is needed	

Section 6 • Soupapes de suspension à air
 • Suspension Air Valves

Soupapes de contrôle
Control Valves

New	Notes
NG12392S	* Manual / Electric replacement actuator for NG12391N & NG12392N
NG12392-C	* Replacement Solenoid Coil <only> for NG12391, 12392 & 12399
NG12392W	Replacement Electrical Socket and Cable for NG12391, 12392 & 12399 * 6 Foot Cable * Includes Gasket and Screw
NG12397	* Replacement Knob <only> for NG12391N, NG12392N
NG12392SP	* Replacement Spool <only> for NG12391, 92, 96, 98, 99

New	Notes
NG12398S	Replacement Actuator for NG12398N
NG12398C	Replacement Coil <only>

New	Notes
NG12399S	Replacement Actuator for NG12399N

New	Notes
NG12400	Replacement "Palm" Knob for NG12392MR, SR, PR, NG12393, 95
NG616-10	Replacement panel-mount Nut for NG12392MR, PR, SR, NG12393, 95

New	Notes
FS-70-2120	* Breather Fitting, 1/8" PT
FS-70-2140	* Breather Fitting, 1/4" PT
FS-70-2160	* Breather Fitting, 3/8" PT



Propriété exclusive de FleetSpec. Toute reproduction interdite. / Exclusive property of FleetSpec. Reproduction prohibited.

Section 6 . Soupapes de suspension à air Suspension Air Valves

Solénoïde électrique à 4-voie 4-Way Electrical Solenoid Valve

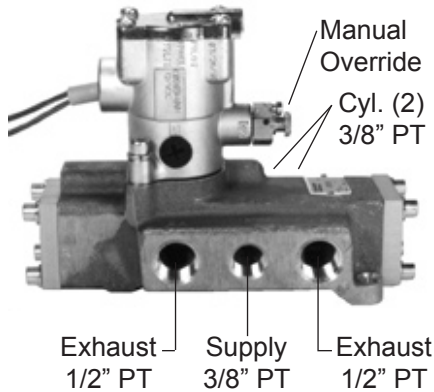

New	Notes
SH12387N	* 2 Position, 5 Port Valve. * 12 Volt Solenoid.
Reman SH12387X	* Manual (locking) Override. * 35 to 140 PSI operation. * 19" long wire, bare ends.
Replaces: Schrader L7053310445 Hendrickson A-12502-021 Tectran 27-S5331	
SH12387EC	End-Cover Repair Kit, with cover, air filter, end-gasket and 4 screws.

New	Notes
SH12387S	* 12 Volt replacement Solenoid. * "Special" -or- Continuous Service. * Manual (locking) Override. * 19" long wire, bare ends. * SH12387MG Metal Gasket included
Replaces: Schrader K085302545 Hendrickson A-12502-031 Tectran 27-K853025	

New	Notes
SH12387SK	* Service Kit to rebuild the Solenoid

New	Notes
SH12387MG	* replacement Metal Gasket for Solenoid mount.

New	Notes
SH12387GK	* Service Kit, to rebuild Solenoid and Spool components. * Our kit includes the SH12387MG replacement Metal Gasket, for improved performance.
Replaces: Schrader K352125 Hendrickson A-12502-023 Tectran 27-K5331RK	

Section 6 • Soupapes de suspension à air
 • Suspension Air Valves

**Soupapes de contrôle
 Control Valves**

New	Notes
NG12401N	* Air Control Valve for Self-Steer Axle. * 12 Volt, with Pilot Air Supply. * Manual Override knob.
Replaces: DeLoupe 30CODEL000	



New	Notes
AK12391N	* 2 Position, 5 (3/8" PT) Port Valve. * 12 Volt Solenoid, Spring Return. * Manual (locking) Override. * 96 SCFM airflow (at full open). * External Pilot supply needed. * 40 PSI to 150 PSI Supply.
Replaces: Manac SP-4904 Ride-Air RA220-1	



Pilot
 1/8" PT

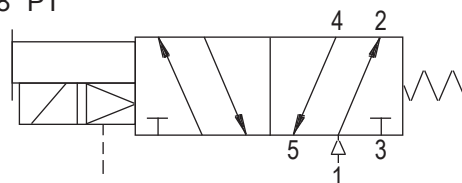

New	Notes
AK12394N	* 2 Position, 3 (3/8" PT) Port Valve. * Air pilot operation, Spring return. * 96 SCFM airflow (at full open). * Inline, or thru hole mounting. * 200 PSI Max supply. * 40 PSI Minimum for pilot pressure.
Replaces: HD Plus ACW4948 Manac SP-4902, 223-6203, 223-6196 Ride-Air RA224-3	



Pilot
 1/4" PT

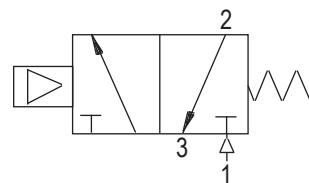

Section 6 • Soupapes de suspension à air
• Suspension Air Valves

**Soupapes de contrôle
Control Valves**

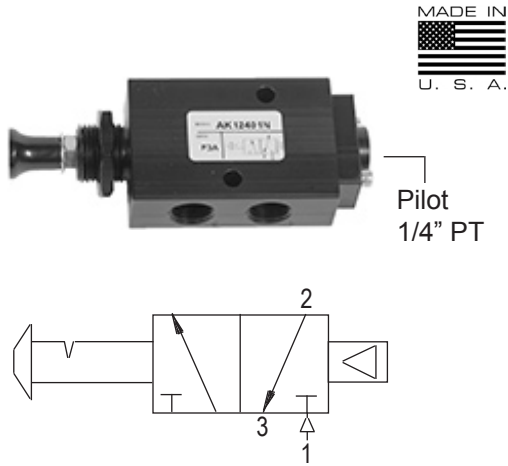

New	Notes
AK12401N	<ul style="list-style-type: none"> * 2 Position, 3 (3/8" PT) Port Valve. * Manual operation, with air pilot reset. Detented in the out position. * 96 SCFM airflow (at full open). * Panel, inline, or thru hole mounting. * 200 PSI Max supply. * 40 PSI Minimum for pilot pressure. * Mini Black Knob.
Replaces: HD Plus ACW4946 Manac SP-4901, 223-6204	

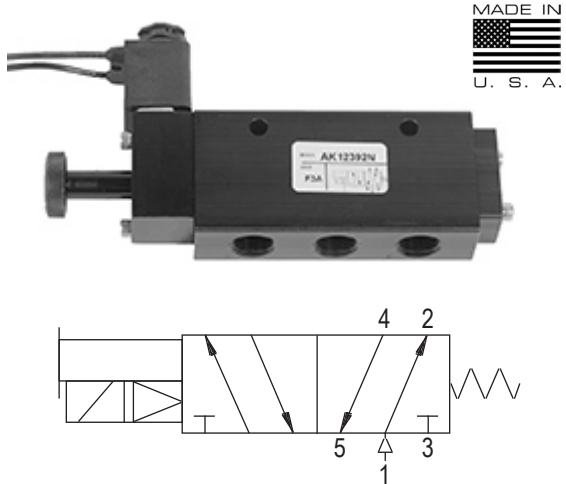

New	Notes
AK12392N	<ul style="list-style-type: none"> * 2 Position, 5 (3/8" PT) Port Valve. * 12 Volt Solenoid, Spring Return. * Manual (locking) Override. * 96 SCFM airflow (at full open). * Mesh screens in ports 1, 2 and 4. * 40 PSI to 150 PSI Supply.
Replaces: HD Plus ACW4944 Manac SP-4900, 223-6197 Ride-Air RA220	



New	Notes
FS-5181	<ul style="list-style-type: none"> * 2 Position, 5 (1/4" PT) Port Valve. * 12 Volt Solenoid * Breather Fittings in ports 3 and 5.
Replaces: Apsco VE-2 Buyers BAV050SA Tectran 29SS4	
FS-5181-C	Replacement Solenoid Coil <only>

Section 6 · Soupapes de suspension à air
 · Suspension Air Valves

Soupape 3-voie à retour automatique
3-Way Auto Reset Control Valves

New	Notes
FS-5177	* 1/4" Breather Fitting included.
Replaces: Hendrickson VS-25223	

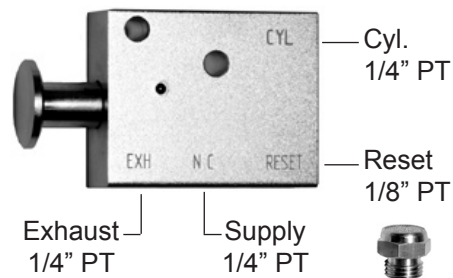

New	Notes
FS-5182	* Exhaust tube and all Push to Connect fittings are included.
Replaces: Hendrickson VS-25224	



Section 6 • Soupapes de suspension à air • Suspension Air Valves

Valves de protection

Pressure Protection Valves



New	Notes
FS-6596	* Normally Closed. Opens at 70 PSI. * Max. operating pressure: 150 PSI. * with Filter in Inlet Port.
Replaces: Williams WM778A1, 118181 Manac 023-150	



New	Notes
FS-6596N	* Normally Closed. Opens at 75 PSI. * Max. operating pressure: 150 PSI.
Replaces: Neway N90554107 Manac 023-290	



New	Notes
FS-6597	* Normally Closed. Opens at 75 PSI. * Max. operating pressure: 150 PSI.
Replaces: Haldex KN31171 Hendrickson A14149	

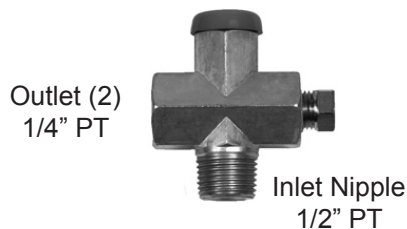

New	Notes
FS-6599	* Normally Closed. Opens at 85 PSI. * Red cap * 1/2" Nipple Mount
Replaces: Paccar 223-585	

Section 6 • Soupapes de suspension à air
 • Suspension Air Valves

Robinets à 3-vois
3-Way Diverter Valves

New	Notes
FS-5174	* All ports (3) are 1/4" PT * Brass housing, with Stainless Steel Ball (for corrosion resistance).
Replaces: Hendrickson A12502-025 Manac 223-292	

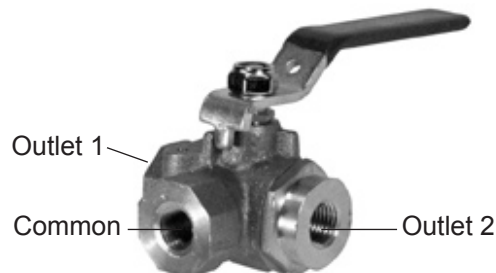

New	Notes
FS-5175	* All ports (3) are 1/4" PT * Brass housing, with Stainless Steel Ball (for corrosion resistance).
Replaces: Hendrickson A22535, VS-22535 Hendrickson AK147-1 Manac 073-034	
FS-5175K	Knob <only> for FS-5175

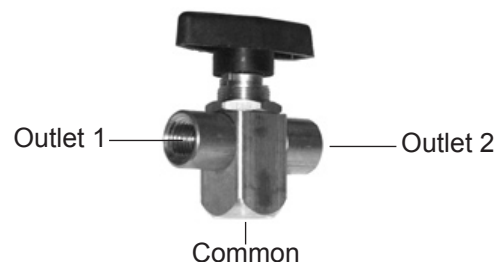

Soupape de contrôle manuel
Manual Control Valve

New	Notes
FS-6580	* Both ports (2) are 1/8" PT * Brass housing for corrosion resistance.
Replaces: Dayton 334-1599; Euclid E4326; Manac 023-138; Neway 90054088	
FS-6580K	Knob <only> for FS-6580
Replaces: Neway 90054211	

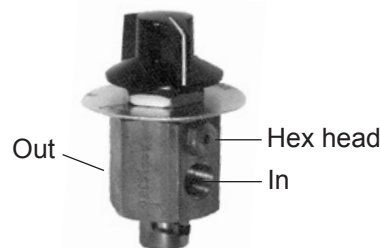

**** Important Note ****
 Reversed connections **WILL**
 cause this valve to leak.

Soupape de décharge rapide
Rapid Dump Valve

New	Notes
FS-5176	* All ports (4) are 1/8" PT
Replaces: GT Dev. 4111, Sloan 401148 Tectran 91-8310, Velvac 032195	

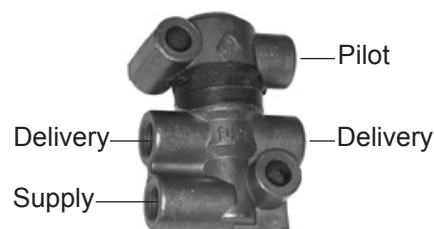

Section 6 . Soupapes de suspension à air . Suspension Air Valves

Soupapes à commande par pilote Pilot Valves

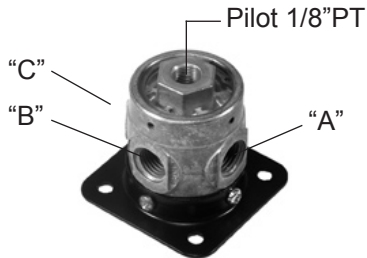

New	Notes	"A"	"B"	"C"
FS-6582	* Normally Open. * Replaces: Neway 90054079	Cyl	Exh	In
FS-6582NC	* Normally Closed.	In	Exh	Cyl
FS-6582U	* Normally Open <or> Closed * Replaces: Neway 90054615	Com	In N/C	In N/O

* Air piloted from 20 to 125 PSI. Ports "A" "B" and "C" are 1/4"
 * Commonly used for Service Line Override on Lift Axles.
 *** NOT intended for Brake System use ***

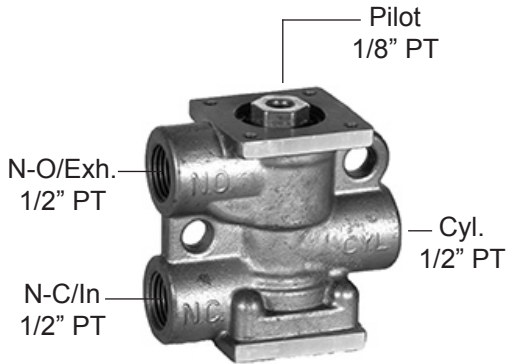
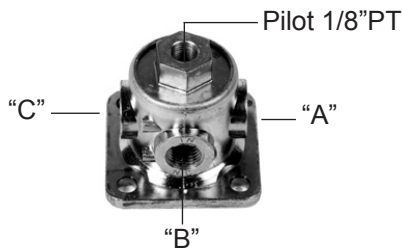

New	Notes
FS-HUM501A	* Two position, Spring Return * Mounts in any position * 275 CFM at 125 PSI
Replaces: Humphrey 501A	

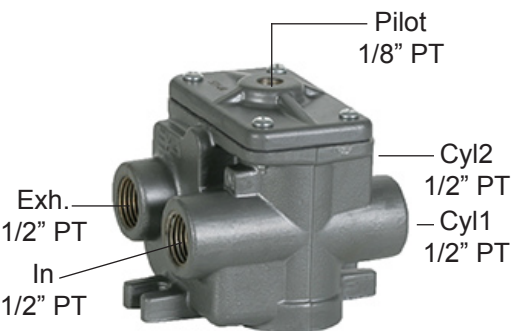

New	Notes
FS-HUM501-4A	* Two position, Spring Return, 4-Way * Mounts in any position * 212 CFM at 125 PSI
Replaces: Humphrey 501-4A	

Section 6 : Soupapes de suspension à air Suspension Air Valves

Solénoïdes électrique à 3-voie 3-Way Electrical Solenoid Valves

New	Notes	"A" 1/4"	"B" 1/4"	"C" 1/4"
FS-4523 *	* 12 Volt, Normally Open. * Closes when Energized. * Replaces: Neway 90054075	In	Exh	Cyl
* Use NG12410N when higher airflow is required				
FS-6581	* 12 Volt, Normally Closed. * Opens when Energized. * Replaces: Neway 90054074	Exh	In	Cyl
FS-6576	* 12 Volt operation. * Normally open or closed. * Manual Override feature. * Replaces: Neway 90054076	Exh N/C	In N/C	Com

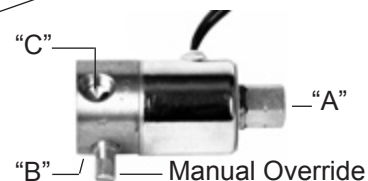

Valves relais Relay Valves

New	Reman	Type	"A" 1/4" PT	"B" 1/8" PT	Closes @ PSI	Reopens @ PSI	Replaces Williams:
FSWM147C	--	NC	Control	Exhaust	--	15-30	111527
FSWM147F	--	NO	Exhaust	Control	30-50	15-30	111531
--	FSWM147LX	NC	Control	Exhaust	--	35-45	130845
FSWM147P	--	NO	Exhaust	Control	10-30	5-10	111542

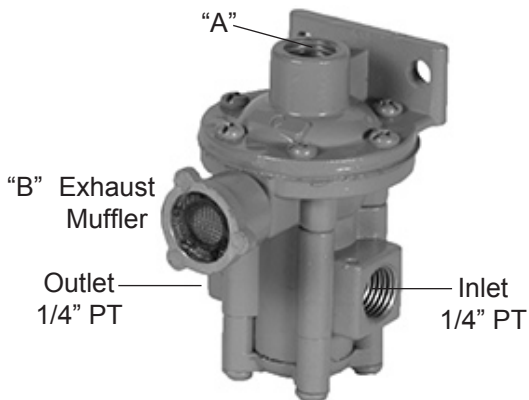

FSWM147C (and L) shown here

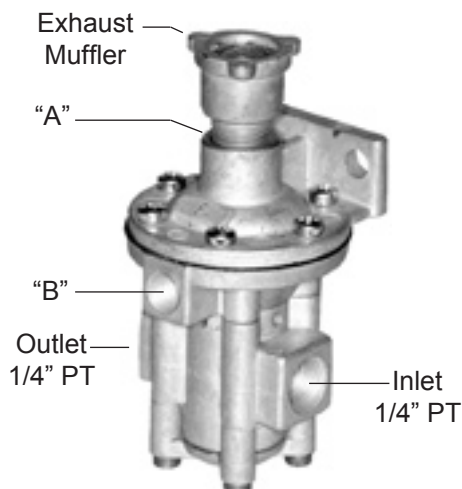

FSWM147F (and P) shown here

Propriété exclusive de FleetSpec. Toute reproduction interdite. / Exclusive property of FleetSpec. Reproduction prohibited.

Section 6 • Soupapes de suspension à air • Suspension Air Valves

Régulateurs de pression Pressure Regulators

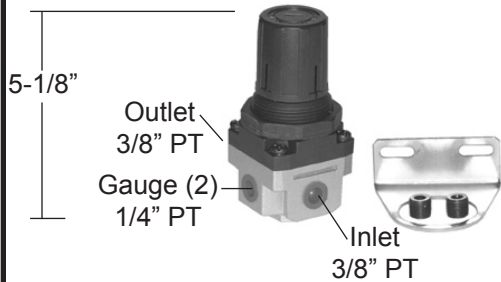

New	Notes
FS-12388	<ul style="list-style-type: none"> * 5-150 PSI regulating range. * 300 PSI max inlet pressure. * Reverse Flow feature * "Push-to-Lock" Adjusting Knob.

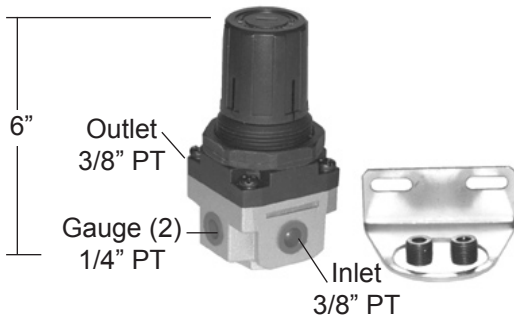

New	Notes
FS-12390	<ul style="list-style-type: none"> * 5-150 PSI regulating range. * 300 PSI max inlet pressure. * Reverse Flow feature. * "Push-to-Lock" Adjusting Knob.
Replaces: Haldex 90054864 Manac 023-3011 Norgren R73R-3AK-RMN Tectran 80-1200	

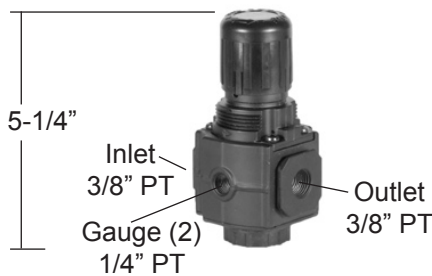

New	Notes
FS-12390oe	<ul style="list-style-type: none"> * 5-150 PSI regulating range. * 300 PSI max inlet pressure. * Reverse Flow feature * "Push-to-Lock" Adjusting Knob.
Replaces: Norgren R73R-3AK-RMN	

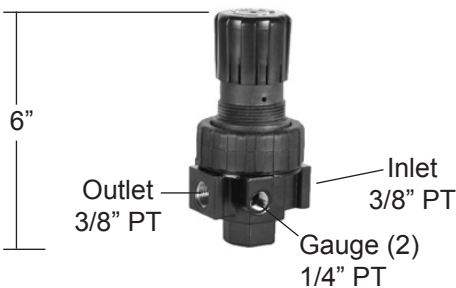

New	Notes
FS-12392	<ul style="list-style-type: none"> * 0-125 PSI regulating range. * 250 PSI max inlet pressure. * Reverse Flow feature. * "Push-to-Lock", non-rising Adjusting Knob.
Replaces: Parker 06R213AC Schrader 035612000B Tectran 27-3561200	
FS-12393	Same specs as above. With 1/4"PT Inlet & Outlet Ports
Replaces: Parker 06R113AC	

Section 6 : Soupapes de suspension à air
 : Suspension Air Valves

New	Notes
FS-6831	* 5-125 PSI regulating range. * 300 PSI max inlet pressure. * "Push-to-Lock" Adjusting Knob.
Replaces: Granning 1066, Hendrickson VS1968 Manac 043-016, Parker 14R013FC Norgren R07-100-RNLA	

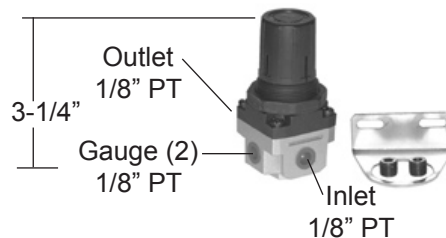

**Manomètres
 Gauges**

New	Notes
FS-6583S	* 2-1/2" Dia. x 1/4" PT Bottom mount. * Silicone liquid filled; Stainless Steel. * reads: 0 to 160 PSI.
Replaces: Ride-Air RA325BL Tectran 27-ADB-15	



New	Notes
FS-6584	* 1-5/8" Dia. x 1/8" PT Bottom mount. * reads: 0 to 160 PSI.



New	Notes
FS-6848S	* 2-1/2" Dia. x 1/4" PT Center mount. * Silicone liquid filled; Stainless Steel. * reads: 0 to 160 PSI.
Replaces: Ride-Air RA325CL	



New	Notes
FS-6849	* 1-5/8" Dia. x 1/8" PT Center mount. * reads: 0 to 160 PSI.
Replaces: Ride-Air RA315C	



Propriété exclusive de FleetSpec. Toute reproduction interdite. / Exclusive property of FleetSpec. Reproduction prohibited.

Section 6 • Soupapes de suspension à air • Suspension Air Valves

Boîtes pour les contrôles de suspension Air Suspension Control Boxes



New	Notes
	* Air Control Box, Empty. * 12" Square, 6-1/2" Deep.
FS-6967-1	* 18 Gauge, Black Powder Coated Steel. * 8 Pre-punched Access Holes.
FS-6967-1NH	* 18 Gauge, Black Powder Coated Steel. * NO Pre-punched Holes.
FS-6967-1SS	* 304 Stainless Steel - no paint. * 8 Pre-punched access holes * 20 Gauge.
FS-6967-1SSNH	* 304 Stainless Steel - no paint. * NO Pre-punched Holes * 20 Gauge.



All pre-built boxes by FleetSpec include:

- * Plumbing Diagram inside the lid.
- * All components listed for easy ID of replacement parts.
- * Rubber lid seal for improved moisture protection.
- * Rubber Door latch.
- * 100% Factory Tested for reliability.

Section 6 : Soupapes de suspension à air : Suspension Air Valves

Boite de contrôle de suspension à air pour essieu relevable (12x12 po.) Air Suspension Standard 12 x 12 inch Lift Axle Control Boxes

FS-6967-1B (With Norgren style Control Valve)

- * Controls the lifting and lowering of the Lift Axle.
- * With the Regulator, you can adjust the Air Ride pressure to the Lift Axle, to control your loads weight distribution.
- * Silicone filled, Stainless Steel pressure gauge, 0-160 PSI.

Replaces: Manac 021-7181, Ride-Air RA012B

FS-6967-1BSS Same as above, in a Stainless Steel Box.

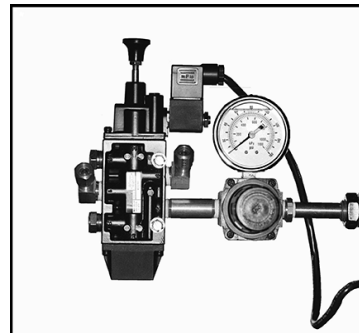

FS-6967-1C (With Norgren style Control Valve)

- * Controls the lifting and lowering of the Lift Axle.
- * With the Regulator, you can adjust the Air Ride pressure to the Lift Axle, to control your loads weight distribution.
- * Silicone filled, Stainless Steel pressure gauge, 0-160 PSI.
- * Lockout Valve eliminates tire damage when the lift axle is up (Lift Axle wheels turn freely).

Replaces: Ride-Air RA012TSR, Tectran 27-ACB-6

FS-6967-1CSS Same as above, in a Stainless Steel box.

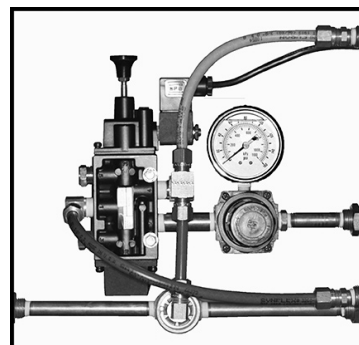

FS-6967-1E (With Ride-Air style Control Valve)

- * Controls the lifting and lowering of the Lift Axle.
- * With the Regulator, you can adjust the Air Ride pressure to the Lift Axle, to control your loads weight distribution.
- * Lockout Valve eliminates tire damage when the lift axle is up (Lift Axle wheels turn freely).
- * Silicone filled, Stainless Steel pressure gauge, 0-160 PSI.

Replaces: Ride-Air RA012, Tectran 27-ACB-6

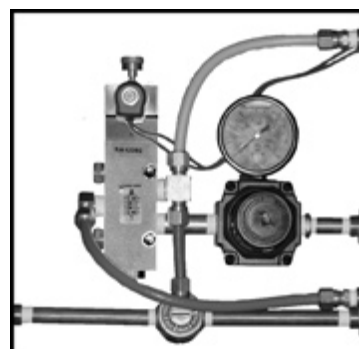

FS-6967-1L (With Schrader style Control Valve)

- * Controls the lifting and lowering of the Lift Axle.
- * With the Regulator, you can adjust the Air Ride pressure to the Lift Axle, to control your loads weight distribution.
- * Silicone filled, Stainless Steel pressure gauge, 0-160 PSI.
- * Lockout Valve eliminates tire damage when the lift axle is up (Lift Axle wheels turn freely).

Replaces: Ride-Air RA012TSR-SWP, Tectran 27-ACB-5

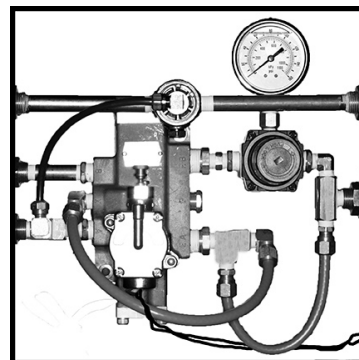

Section 6 • Soupapes de suspension à air • Suspension Air Valves

Boîtes de contrôle pour essieu relevable et d'évacuation de l'air de la suspension pneumatique (12x12po.)

Air Suspension Standard 12 x 12 inch Lift Axle & Air Suspension Dump Control Boxes

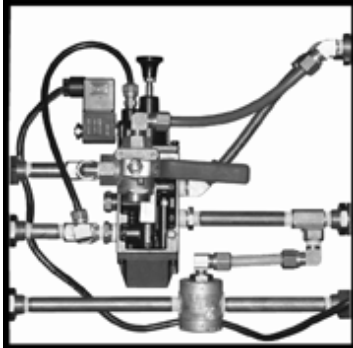

FS-6967-1A (With Norgren style Control Valve)

- * Controls the lifting and lowering of the Lift Axle, and Ride Bags system dump.
- * The Suspension Height Control Valve controls the Air Ride pressure for all axles, including the Lift Axle.
- * Lockout Valve (A) eliminates tire damage when the lift axle is up (Lift Axle wheels turn freely).

Replaces: Ride-Air RA013S, Tectran 27-ACB-8

FS-6967-1ASS Same as above, in a Stainless Steel Box.

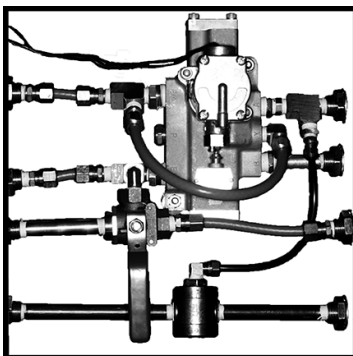

FS-6967-1K (With Schrader style Control Valve)

- * Controls the lifting and lowering of the Lift Axle, and Ride Bags system dump.
- * The Suspension Height Control Valve controls the Air Ride pressure for all axles, including the Lift Axle.
- * Lockout Valve (A) eliminates tire damage when the lift axle is up (Lift Axle wheels turn freely).

Replaces: Tectran 27-ACB-2

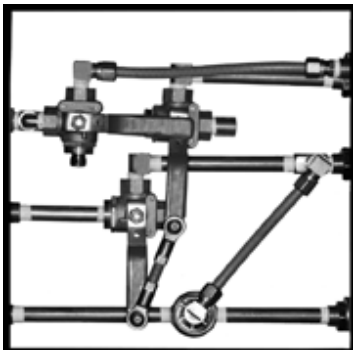

FS-6967-1AM

- * Controls the lifting and lowering of the Lift Axle, and Ride Bags system dump.
- * **Full MANUAL operation**
- * The Suspension Height Control Valve controls the Air Ride pressure for all axles, including the Lift Axle.
- * Lockout Valve eliminates tire damage when the lift axle is up (Lift Axle wheels turn freely).

Section 6 • Soupapes de suspension à air • Suspension Air Valves

Boîtes de contrôle pour essieu relevable autovireur Liftable Steer Axle Control Boxes

FS-6967-1FSS (With Schrader style Control Valve)
* Stainless Steel 12x12 Box

- * With Auto Torpress Regulator.
- * Minimum pre-set regulator @ 25 PSI.
- * Lockout Valve eliminates tire damage when the lift axle is up (Lift Axle wheels turn freely).
- * Suspension Height Control Valve controls the air ride pressure for ALL axles, including the liftable Steer Axle.

Replaces: Ride-Air RA016SRP-31

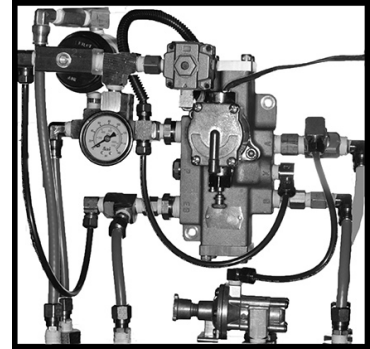

FS-6967-1J (With Ride-Air style Control Valve)

- * With Auto Torpress Regulator.
- * Minimum pre-set regulator @ 25 PSI.
- * Lockout Valve eliminates tire damage when the lift axle is up (Lift Axle wheels turn freely).
- * Suspension Height Control Valve controls the air ride pressure for ALL axles, including the liftable Steer Axle.

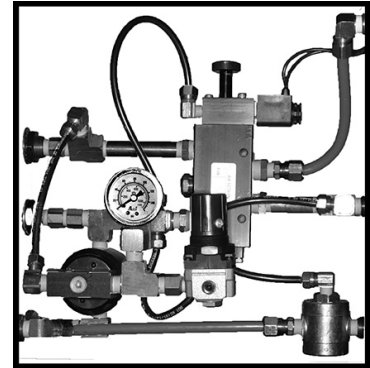

Section 6 · *Soupapes de suspension à air*
· *Suspension Air Valves*

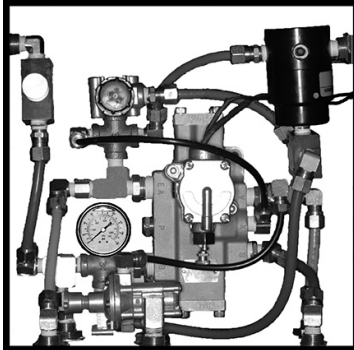
**Boîtes de contrôle pour essieu relevable autovireur,
et d'évacuation de l'air**
Liftable Steer Axle Control Boxes with Dump Control**FS-6967-1G** (With Schrader style Control Valve)

- * With Auto Torpress Regulator.
- * Minimum pre-set regulator @ 25 PSI.
- * Manual valve to dump & reload air from Primary & Steer Axle Air Springs
- * Lockout Valve eliminates tire damage when the lift axle is up (Lift Axle wheels turn freely).
- * Suspension Height Control Valve controls the air ride pressure for ALL axles, including the liftable Steer Axle.

Replaces: Ride-Air RA016SRP-32

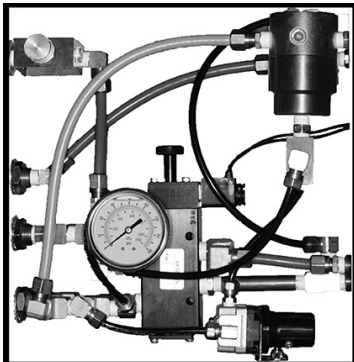
**FS-6967-1M** (With Ride-Air style Control Valve)

- * With Auto Torpress Regulator.
- * Minimum pre-set regulator @ 25 PSI.
- * Manual valve to dump & reload air from Primary & Steer Axle Air Springs
- * Lockout Valve eliminates tire damage when the lift axle is up (Lift Axle wheels turn freely).
- * Suspension Height Control Valve controls the air ride pressure for ALL axles, including the liftable Steer Axle.

Replaces: Ride-Air RA016SSN-32

Section 6 • Soupapes de suspension à air
 • Suspension Air Valves

Pièces divers
Miscellaneous Parts

New	Notes
FS-6967-1D	* Door Kit for FS-6967-1 (black) Box.
FS-6967-2D	* Door Kit for FS-6967-2 Box.
Kit contains: Door, Hinge Pin, Latch, Cotter Pin, and Pin Mount.	
FS-6967-L	* Latch Kit, fits any Box.
Kit contains: Latch, Cotter Pin, and Pin Mount.	
FS-6967-P	* Hinge Pin for FS-6967-1 Box.
FS-6967-1H	* Hinge (with Pin) for FS-6967-1 Box



New	Notes
FS-317E	* Steel Terminal Bolt. * 1/4" Female PT x 1" long.



New	Notes
FS-6970	* 7/8" Grommet, with 3/8" Pass-thru.
FS-6971	* 7/8" Snap-in Hole Plug.



New	Notes
FS-70-2120	* Breather Fitting, 1/8" PT
FS-70-2140	* Breather Fitting, 1/4" PT
FS-70-2160	* Breather Fitting, 3/8" PT



Section 6 • Soupapes de suspension à air • Suspension Air Valves

Boîtes pour les contrôles de suspension Clear Cover Suspension Control Boxes



New	Notes
FS-6967-6	6" square, 3-1/2" deep.
FS-6967-7	8" wide, 10-1/2" tall, 6" deep.
Composite construction, with clear covers, and rubber door seals - Very rugged design.	



Boîtes de contrôle d'évacuation de l'air de la suspension pneumatique Air Suspension Dump Control Boxes



- > Rugged all weather, light weight compact composite box, with Weather Seal.
- > **Minimum** parts, for **Maximum** reliability
- > *Easy to install*, with Push-To-Connect fittings

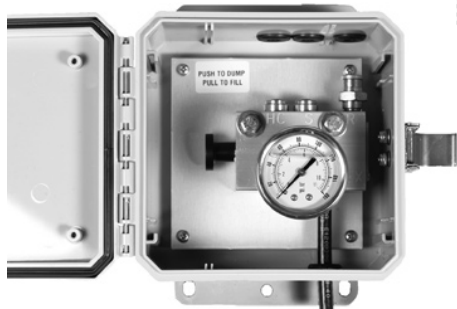

New	Notes
FS-6967-6A	* Durable composite construction. * 6-1/2" square, 4" deep * Manual operation, with Air Reset
Reset port ties into Parking Brake. When Parking Brakes are released, dump valve resets and air flows freely from Height Control Valve to Air Springs.	

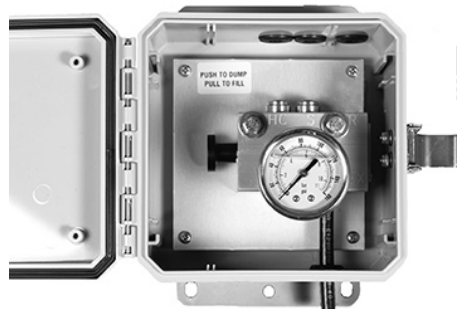

New	Notes
FS-6967-6B	* Durable composite construction. * 6-1/2" square, 4" deep * Full Manual operation.

Propriété exclusive de FleetSpec. Toute reproduction interdite. / Exclusive property of FleetSpec. Reproduction prohibited.

Section 6 : Soupapes de suspension à air Suspension Air Valves

Boîtes pour les contrôles de suspension Air Suspension Control Boxes

New	Notes
	* Air Control Box, Empty. * 8-1/4" Square, 4-1/4" Deep.
FS-6967-2	* 18 Gauge, Black Powder Coated Steel. * NO Pre-punched Holes.
FS-6967-2F	* 18 Gauge, Black Powder Coated Steel. * 3 Pre-Punched Access Holes.
FS-6967-2SS	* 304 Stainless Steel - no paint * 20 Gauge * NO Pre-punched Holes. Replaces: Ride-Air RA001TS



All pre-built boxes by FleetSpec include:

- * Plumbing Diagram inside the lid.
- * All components listed for easy ID of replacement parts.
- * Rubber lid seal for improved moisture protection.
- * Rubber Door latch.
- * 100% Factory Tested for reliability.

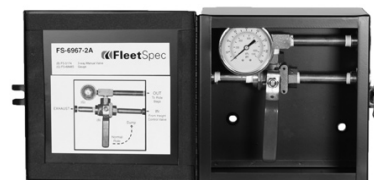

Section 6 • Soupapes de suspension à air • Suspension Air Valves

Boîtes de contrôle d'évacuation de l'air de suspension pneumatique (8-1/4 x 8-1/4 po.) Air Suspension 8-1/4 x 8-1/4 inch Dump Control Boxes



- * Used to manually exhaust the Air Ride Suspension while the trailer is docked.
- * 3-Way Hand Control Diverter Valve.
- * Silicone filled, Stainless Steel pressure gauge, 0-160 PSI
- * Gauge indicates air pressure in the suspension, which can be used in calculating the load weight.

FS-6967-2A

Replaces: Meritor R986058
 Ride Air RA014GL
 Tectran 27-ADB-15, 27-ADB-66

FS-6967-2ASS Same as above, in a Stainless Steel Box
 Replaces: Ride-Air RA014GLS

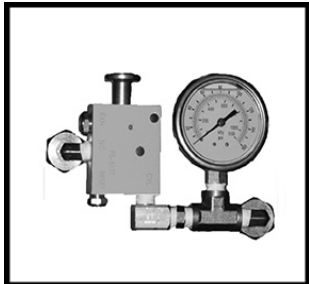

FS-6967-2E

- * 3-Way Push-Pull Diverter Valve.

Replaces: Ride Air RA015GL

FS-6967-2ESS Same as above, in a Stainless Steel Box
 Replaces: Ride-Air RA015LS

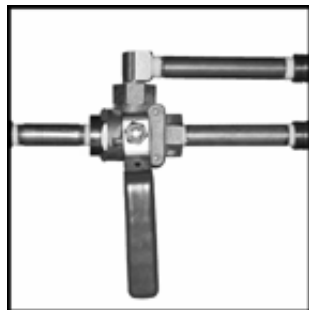

FS-6967-2B

- * Used to manually exhaust the Air Ride Suspension while the trailer is docked.
- * 3-Way Hand Control Diverter Valve.

Replaces: Ride-Air RA014, Tectran 27-ADB-12

FS-6967-2BSS Same as above, in a Stainless Steel Box
 Replaces: Tectran 27-ADB-16



FS-6967-2C

- * Used to electrically exhaust the Air Ride Suspension while the trailer is docked.
- * 3-Way Electric Solenoid Valve.

Section 6 : Soupapes de suspension à air
: Suspension Air Valves

Boîtes pour les contrôles de suspension
Air Suspension Control Boxes

New	Notes
FS-6967-3	* Air Control Box, Empty. * Black Powder Coated Steel. * 10" High, 18" Long, 6" Deep.



New	Notes
FS-6967-3D	* Door Kit for FS-6967-3 * Foam Seal included. * Latch & Cotter Pin included.



Section 6 • Soupapes de suspension à air • Suspension Air Valves

Boîtes pour les contrôles de suspension Air Suspension Control Boxes



New	Notes
FS-6967-4	* Air Control Box, Empty. * Black High-Gloss Painted Steel. * Foam Door Seal included. * 10" High, 12" Wide, 6" Deep.
Replaces: Manac 482-9041	



Back view



New	Notes
FS-6967-4D	* Door for FS-6967-4 Box. * Foam Seal included. * Latch & Cotter Pin included.
Replaces: Manac 582-90411	



New	Notes
FS-6967-5	* Air Control Box, Empty. * Black Powder Coated 18 Ga. Steel. * Foam Door Seal included. * 10" High, 18" Wide, 6" Deep.
Replaces: Manac 223-354	



Back view



New	Notes
FS-6967-5D	* Door for FS-6967-5 Box. * Foam Seal included.
Replaces: Manac 492-910	
FS-6967-5L	* Latch Kit for FS-6967-5 Box



Section 6 : Soupapes de suspension à air
 : Suspension Air Valves

Boîtes de contrôle pour essieu auto-vireur relevable, avec contrôle de vidange d'air
Liftable Steer Axle Control Boxes, with Dump Control

New	Notes
FS-6967-5A	<ul style="list-style-type: none"> * Steerable Lift Axle MUST be lifted (Up position) when backing up. * Controls the lifting and lowering of the Lift Axle, and Ride Bags system dump. * Suspension Height Control Valve controls Air Ride Pressure for ALL axles, including the Lift Axle. * Lockout Valve (A) eliminates tire damage when the Lift Axle is up. (Lift Axle Wheels turn freely) * Silicone filled, Stainless Steel Pressure Gauge, 0 to 160 PSI. * REQUIRES Control Box FS-6967-8A to control the Torpress Air Bag.
Replaces: Manac 072-0561	

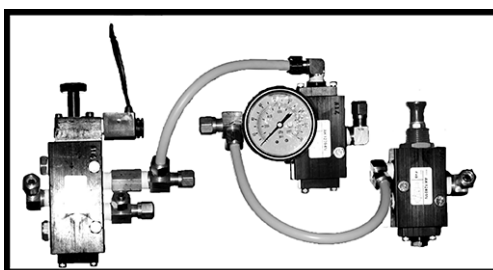

New	Notes
FS-6967-5B	<ul style="list-style-type: none"> * Controls the lifting and lowering of the Lift Axle, and Ride Bags system dump. * Suspension Height Control Valve controls Air Ride Pressure for ALL axles, including the Lift Axle. * For Reverse Operation (Backing up), the Self-Steering Axle MUST be lifted. This activates the Locking Cylinder automatically. (Prevents Self-Steer Axle wheels from turning) * Lockout Valve (A) eliminates tire damage when the Lift Axle is up. (Lift Axle Wheels turn freely) * Silicone filled, Stainless Steel Pressure Gauge, 0 to 160 PSI. * REQUIRES Control Box FS-6967-8A to control the Torpress Air Bag.

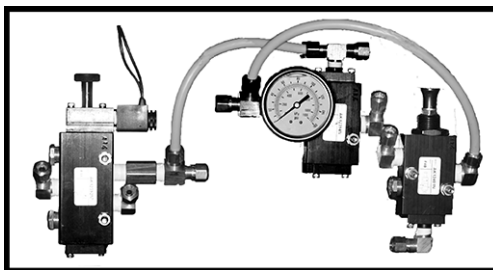

Section 6 . Soupapes de suspension à air . Suspension Air Valves

Boîtes pour les contrôles de suspension Air Suspension Control Boxes



Back
view

New	Notes
FS-6967-8	* Air Control Box, Empty. * Black Powder Coated Steel. * Foam Door Seal included. * 8-1/4" Square, 4-1/2" Deep.
Replaces: Manac 223-352	

Boîtes de contrôle pour essieu relevable autovireur, Lifiable Steer Axle Torpress Air Bag Control Box (8-1/4" square)

New	Notes
FS-6967-8A	* With the Regulator, you can adjust the Air Ride Pressure to the Self-Steering Lift Axle Torpress Air Bag, to control the drivability of the self-steering axle. * Silicone Filled, Stainless Steel Gauge, 0 to 160 PSI.



Section 6 : Soupapes de suspension à air
: Suspension Air Valves

Notes



Section 7

Soupapes à fonctions diverses
Miscellaneous Air Valves

Section 7 • Soupapes à fonctions diverses • Miscellaneous Air Valves

Soupapes servo-pneumatique de passation des vitesses Transmission Air Shift Valves

New	Ports	Side Button
FSA6909N	1/16" PT (3)	None
For 7L, 8, 8L, 9 and 10 speed models. Replaces: Eaton / Fuller A-6909		



New	Ports	Side Button
FSA6913N	1/16" PT (5)	Red
For 13 speed models. Replaces: Eaton / Fuller A-6913		



New	Ports	Side Button
FSA6915N	1/16" PT (5)	Blue
For 7LL, 8LL, 9MLL and 15 speed models. Replaces: Eaton / Fuller A-6915		



New	Ports	Side Button
FSA6918N	1/16" PT (4)	Grey
For 18 speed models. Replaces: Eaton / Fuller A-6918		



Section 7 . Soupapes à fonctions diverses . Miscellaneous Air Valves

Soupape de transmission Transmission Range Valve

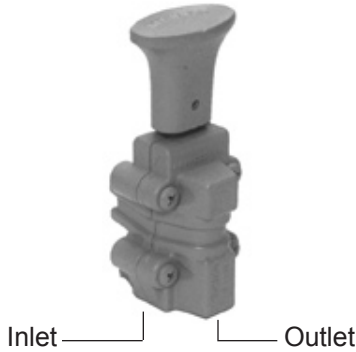

New	Reman	Ports
FSA3546N	FSA3546X	1/8" (2)
Replaces: Eaton / Fuller A-3546		

Soupape de transmission Transmission Range Slave Valve

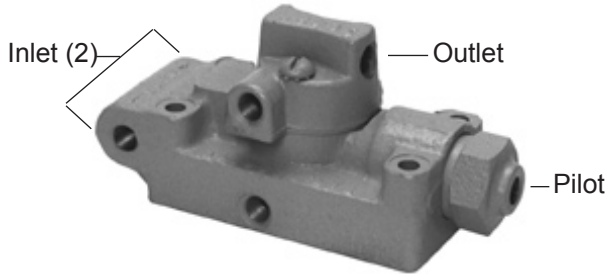

New	Reman	Ports
—	FSA4688X	1/8" (6)

Soupape de porte arrière de camion-benne Dump Truck Rear Door Valve

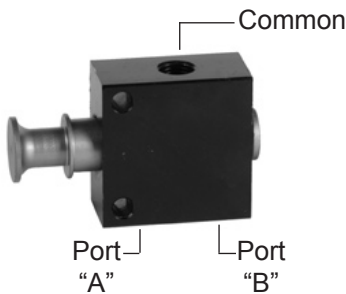

New	Notes
FS-5178	* All ports (3) 1/4" PT * Includes 3 Fittings
Used on Dump Trucks to unlock the Rear Door Replaces: Apsco V-8	

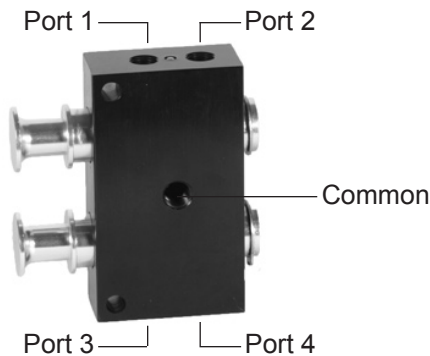

New	Notes
FS-5178DB	* All ports (5) 1/8" PT
Used on Dump Trucks with Pup Trailers, to unlock the rear doors individually. Replaces: Apsco V-88	

Section 7 • Soupapes à fonctions diverses • Miscellaneous Air Valves

Soupape de hayon élévateur Tailgate Control Valves

New	Notes
FS-12391B	* 3-Position, 5 (1/4" PT) Port Valve. * 1/4" Breather Fittings (2) included.
Replaces: Buyers BAV020	

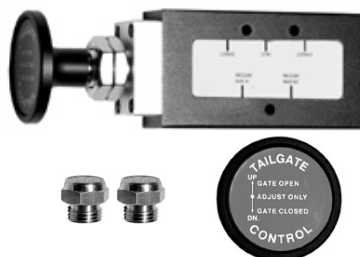

New	Notes
FS-6593	* All ports (5) are 1/8" PT. * 1/8" Breather Fittings (2) included. * Only 2-3/4" (70mm) long
Replaces: Buyers BAV010, Velvac 320124	



New	Notes
FS-5181	* 2 Position, 5 (1/4" PT) Port Valve. * 12 Volt Solenoid * Breather Fittings in ports 3 and 5.
Replaces: Apsco VE-2 Buyers BAV050SA Tectran 29SS4	
FS-5181-C	Replacement Solenoid Coil <only>



Valve de vérin pneumatique Air Cylinder Valves

New	Notes
VE320121MR	* Two Position Valve * Operates double acting cylinders. * Replaces: Velvac 320121
VE320122MR	* Three Position Holding Type Valve * Operates systems where full air pressure (or vacuum) must be isolated. (Air Bags, Lift Gates, etc) * Replaces: Velvac 320122
* All ports (5) are 1/4" PT. * 2 Labels included, White text on Red. - Pull to Raise / Push to Lower - Pull to Open / Push to Close	



Section 7 . Soupapes à fonctions diverses • Miscellaneous Air Valves

Régulateurs de pression

5th Wheel Air Toggle Switch



New	Notes
FS-5180	General purpose On-Off Air Toggle Switch
Replaces: Holland XA-02048 Velvac 032138	

Valve à air à bascule Toggle Air Valves

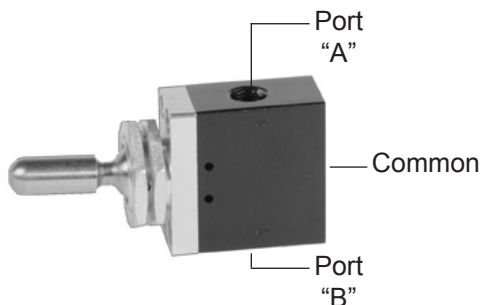

New	Notes
FS-5179T	* Toggle returns to center when released. * All Ports (3) are 1/8" PT
Replaces: Buyers BAV020T	
FS-5179TD	* Toggle remains where set. * All Ports (3) are 1/8" PT
Replaces: Buyers BAV020TD	

Régulateurs de pression Pressure Regulators

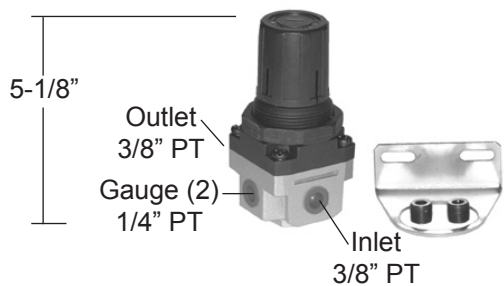

New	Notes
FS-12387	* 5-150 PSI regulating range. * 300 PSI max inlet pressure. * "Push-to-Lock" Adjusting Knob.

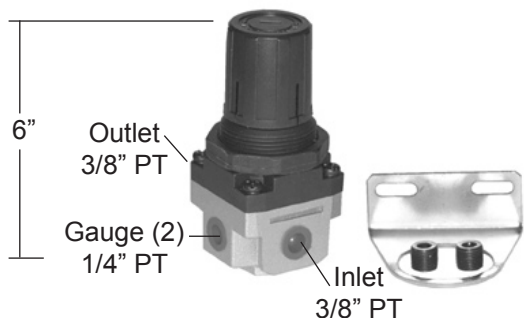

New	Notes
FS-12389	* 5-150 PSI regulating range. * 300 PSI max inlet pressure. * "Push-to-Lock" Adjusting Knob.

Propriété exclusive de FleetSpec. Toute reproduction interdite. / Exclusive property of FleetSpec. Reproduction prohibited.

Section 7 · *Soupapes à fonctions diverses*
· *Miscellaneous Air Valves*

Notes





Section 8

Têtes d'accouplement & accessoires
Gladhands & Air Accessories

Section 8 . Têtes d'accouplement & accessoires
 Gladhands & Air Accessories

Joint d'étanchéité pour têtes d'accouplement
Gladhand Seals

New	Notes
FS-312B	* Blue Polyurethane, Surface Sealing. * Replaces: Midland DA9017B
FS-312K	* Black Polyurethane, Surface Sealing.
FS-312R	* Red Polyurethane, Surface Sealing. * Replaces: Midland DA9017R



New	Notes
FS-312BS	* Blue Polyurethane, Surface Sealing. * With Screen
FS-312BRS	* Set of 2 Blue & 2 Red Polyurethane, Surface Sealing, with 4 Screens
FS-312RS	* Red Polyurethane, Surface Sealing. * With Screen



New	Notes
FS-312	* Black Rubber, Surface Sealing type. * Replaces: Midland 10028



New	Notes
FS-312A	* Black Rubber, Sealed type. * Replaces: Midland 10024

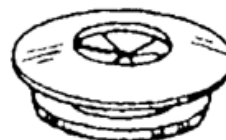

Section 8 • Têtes d'accouplement & accessoires Gladhands & Air Accessories

Têtes d'accouplement Gladhands



New	Straight Mount
FS-313E	Emergency: Red coded Replaces: Phillips 12-008, Sloan 441016
FS-313S	Service: Blue coded Replaces: Phillips 12-006, Sloan 441015
Aluminum construction, with Steel Wear & Color Plates. 1/2" NPT Pipe Port, FS-312 Gladhand Seal included.	



New	Shut-off Gladhands
FS-318E	Emergency: Red coded Replaces: Phillips 12-308, Sloan 035095
FS-318S	Service: Blue coded. Replaces: Phillips 12-306, Sloan 035094
Aluminum construction, with Steel Color Plates. Bulkhead fitting, with 3/8" NPT fitting 3/8" Air Tube connector provided. FS-312 Gladhand Seal included.	



New	38° Bracket Mount, with Bottom Port
FS-319E	Emergency: Red coded Replaces: Phillips 12-138, Sloan 441019
FS-319S	Service: Blue coded Replaces: Phillips 12-136, Sloan 441023
Aluminum construction, with Steel Color Plates. 2 x 3/8" NPT Pipe Ports (rear port plugged). FS-312 Gladhand Seal included.	

Section 8 • Têtes d'accouplement & accessoires
 • Gladhands & Air Accessories

**Têtes d'accouplement
 Gladhands**

New	Surface Mount with Shut-Off
FS-320E	Emergency: Red coded Replaces: Sloan 441014
FS-320S	Service: Blue coded Replaces: Sloan 441004
Aluminum construction, with Steel Color Plates. 3/8" NPT Pipe Port, FS-312 Gladhand Seal included.	



New	"Dummy" Coupling
FS-321	16" Cable, looped. Replaces: Phillips 12-0100
Aluminum construction, with Steel Wear Plate. NO Gladhand Seal required.	



New	45° Bracket Mount Swivel Gladhands
FS-322E	Emergency: Red coded Replaces: Tectran 9222
FS-322S	Service: Blue coded. Replaces: Tectran 9221
Aluminum construction, with Steel Wear & Color Plates. FS-312 Gladhand Seal included.	

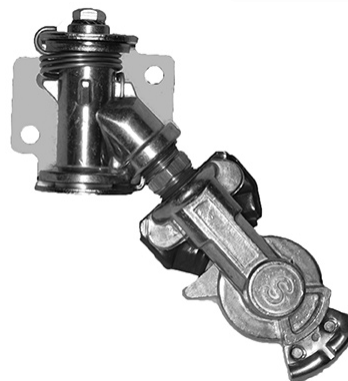

New	45° Bracket Mount Swivel Gladhands with Shut-Off
FS-323E	Emergency: Red coded Replaces: Tectran 9218
FS-323S	Service: Blue coded. Replaces: Tectran 9219
Aluminum construction, with Steel Color Plates. FS-312 Gladhand Seal included.	



Propriété exclusive de FleetSpec. Toute reproduction interdite. / Exclusive property of FleetSpec. Reproduction prohibited.

Section 8 • Têtes d'accouplement & accessoires Gladhands & Air Accessories

Poignées de rallonge pour tête d'accouplement Gladhand Grip Extensions

New	Notes
FS-315	<ul style="list-style-type: none"> * 1-Piece design, made from solid aluminum. * Red & Blue Anodized - Won't fade or wear off. * Knurled grip surface - Won't slip. * 1/2" NPT Male & Female threads, with Thread Sealant pre-applied to the male threads. * Set of 2, in Clamshell Packaging. * Replaces: Phillips 12-600

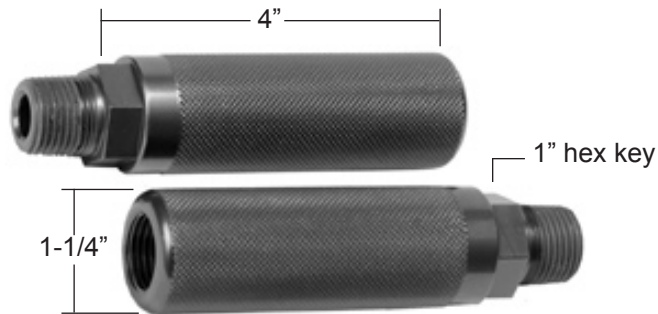

Poignées pour tête d'accouplement Gladhand Grip Handles

New	Notes
FS-324	<ul style="list-style-type: none"> * Easy to install 2-piece Red & Blue colour coded handles. * Prevents airhose kinking at Gladhands. * 1/2" NPT Male Gladhand & 1/2" Female Airline * Set of 2, in Clamshell Packaging. * Replaces: Sloan 441751



Section 8 · Têtes d'accouplement & accessoires
 · Gladhands & Air Accessories

Valves de desserrage rapide de conduite
In-Line Quick Release Valves

New	Notes
FS-6605	<ul style="list-style-type: none"> * Mounts between truck Tractor Protection valve and Emergency Air Line. * Provides faster release of air pressure from trailer emergency line for faster application of trailer parking brake. * Brown Sleeve.
Replaces: Sloan 401145, Phillips 12-810	

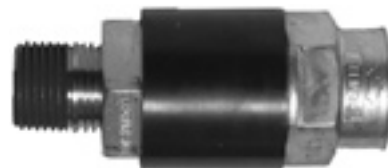

Air Flow →

New	Notes
FS-6606	<ul style="list-style-type: none"> * Mounts at truck Service Gladhand. * Provides faster release of air pressure from trailer brake line, for faster release of service brakes. * Black Sleeve.
Replaces: Sloan 401146, Phillips 12-811	



Section 8 · Têtes d'accouplement & accessoires Gladhands & Air Accessories

Ressorts de support pour boyau Hose Support Springs

New	O.D.	Length	Replaces
FS-3056	3/4"	12"	Midland 11601
FS-3057	1"	12"	Midland 11602
FS-3058	1-1/16"	16"	Midland 11603
FS-3055	1-1/8"	25"	Midland 11600

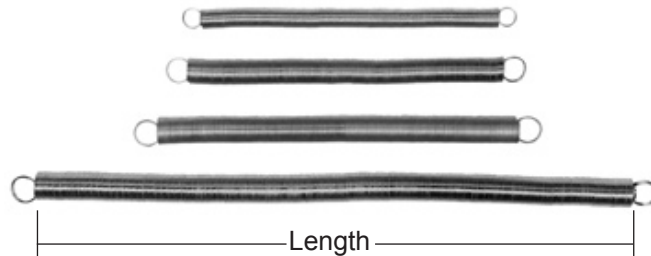

Verrouillage du tête d'accouplement Gladhand Lock

New	Notes
FS-316	* Red Powder Coated Steel. * 2 Keys provided. * Available "Keyed Alike" in cases of 12 pcs.



Section 8 • Têtes d'accouplement & accessoires
 • Gladhands & Air Accessories

Séparateurs de boyau
Hose Separators

New	Notes
FS-473	* For 3/8" Air Hoses. * Replaces: Midland 11548
FS-473A	* For 1/2" Air Hoses. * Replaces: Midland 11549



New	Notes
FS-473D	* Double, for 3/8" Air Hoses.
FS-473AD	* Double, for 1/2" Air Hoses.



Brides de retenu pour boyau à air
Air Hose Clamps

New	Notes
FS-5143	* Two 3/4" holes for 3/8" I.D. Air Lines, and a center hole for a 7-conductor Electrical Cable. * Replaces: Midland 11544



New	Notes
FS-5147	* Two 3/4" holes for 3/8" I.D. Air Lines. * Replaces: Midland 11541



New	Notes
FS-5150	* Two 3/4" holes for 3/8" I.D. Air Lines, and a center hole for a 7-conductor Electrical Cable. * Replaces: Midland 11543



Section 8 · Têtes d'accouplement & accessoires
· Gladhands & Air Accessories

Notes



Section 9

Accessoires électriques
Electrical Accessories

Section 9 • Accessoires électriques • Electrical Accessories

Robinet électro-pneumatique Solenoid Air Valve

New	Notes
FSKN68230N	<ul style="list-style-type: none"> * Normally Closed. * Exhaust is under white plastic cover. * Both ports (2) are 1/4" PT. * 12 Volt operation. * Operates the shift mechanism of a two-speed axle.
Replaces: Midland KN68230	

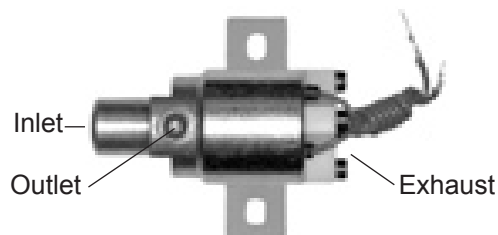

Aiguillages à commande électro-pneumatique Electro-Pneumatic Switches

New	Notes
FSBE13240N	Tractor Spring Brake Circuit Light Switch. <ul style="list-style-type: none"> * Actuates at 55 PSI. Normally Closed at 0 PSI. * Single pole, 2 terminals. * 12 or 24 Volt operation.
Replaces: Midland BE13240	



1/8" PT

New	Notes
FSBE13250N	Service Circuit Stoplight Switch. <ul style="list-style-type: none"> * Actuates between 3 and 5 PSI. * Normally Open at 0 PSI. * Single pole, 2 terminals. * 12 or 24 Volt operation.
Replaces: Midland BE13250	



1/4" PT

New	Notes
FSBE13255N	Trailer Emergency Stoplight Switch. <ul style="list-style-type: none"> * Actuates at 55 PSI. * One side Open at 0 PSI, other side Closed. * Single pole, double throw, 3 terminals. * 12 or 24 Volt operation.
Replaces: Midland BE13255	



1/8" PT

Section 9 . Accessoires électriques . Electrical Accessories

Boîtes de jonctions électrique Electrical Junction Boxes



New	Notes
FS-3583-8	7 Connector block, with 5 access ports. * 4 Rubber grommets with pass-thru holes. * 4 Rubber block-off grommets. * Pins labeled : GRD. / CLEAR / L.TURN / STOP / R.TURN / TAIL / AUX.
Replaces: Midland 22010 / 22040 Phillips 15-960 Tectran 667-7040	

See-thru polycarbonate

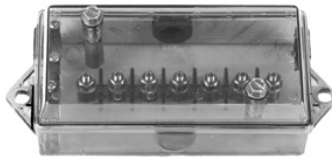

New	Notes
FS-3585-8	7 Connector block, with 5 access ports. * Molded from Smoked see-thru Polycarbonate material. * Molded Gasket seals the Lid. * 4 Rubber grommets with pass-thru holes. * 4 Rubber block-off grommets. * Pins labeled : GRD. / CLEAR / L.TURN / STOP / R.TURN / TAIL / AUX.
Replaces: Phillips 15-961 Tectran 667-7080	

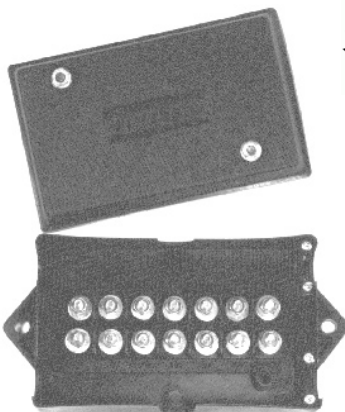

New	Notes
FS-3584	14 Connector block, with 6 access ports. * 5 Rubber grommets with pass-thru holes. * 5 Rubber block-off grommets. * Row 1 Pins labeled : ABS / TAIL / R.TURN / STOP / L.TURN / CLEAR / GRD. * Row 2 Pins labeled : GRD. / AUX. / ABS-MALF / AUX / AUX / AUX / ALT-ABS
Replaces: Tectran 667-1440	



Section 10

Accessoires de camion & remorque
Truck & Trailer Accessories

Section 10 : Accessoires de camion & remorque Truck & Trailer Accessories

Cales d'espacement de roue Wheel Spacers

New	Bolt Circle	Bolt Holes	Notes	Replaces
WG5901	11-1/4"	10 x 7/8 10 x 1-1/8	Stud-piloted	Accuride 590-1
WG5902	11-1/4"	10 x 3/4"	Stud-piloted	Accuride 590-2
WG5903	285.75mm	10 x 22mm	Hub-piloted	Accuride 590-3
WG7381	335mm	10 x 22mm	Hub-piloted ISO European mount	Accuride 738-1
WG7902	225mm	8 x 22mm	Hub-piloted	Accuride 790-2

These Nylon spacers are approximately 0.045" thick. They are placed between the hub or drum and the wheel, and/or between two wheels in dual applications. The spacers are recommended in applications where corrosion and / or wear are, or can become an issue. Both aluminium and steel wheels can benefit from the use of these spacers.

WARNING: Care must be exercised in centering the spacers prior to torqueing and stud length must be adequate to ensure proper torqueing as spacers are 0.045" thick. Furthermore, It is *not* recommended to use these spacers in vocational applications equipment like dump trucks, cement mixers and any heavy haul equipment floats where excessive heat from braking can become an issue.



Section 10 • Accessoires de camion & remorque
 • Truck & Trailer Accessories

**Capuchons de moyeu
 Hub Caps**

New	Notes
FS-34009WMP	* Comes with the FS-5984 Magnetic Drain Plug pre-installed. * Simply remove the plug, and see if metal particles are attached to the magnet. This helps to identify impending bearing failure.
	Replaces: Stemco 343-4009

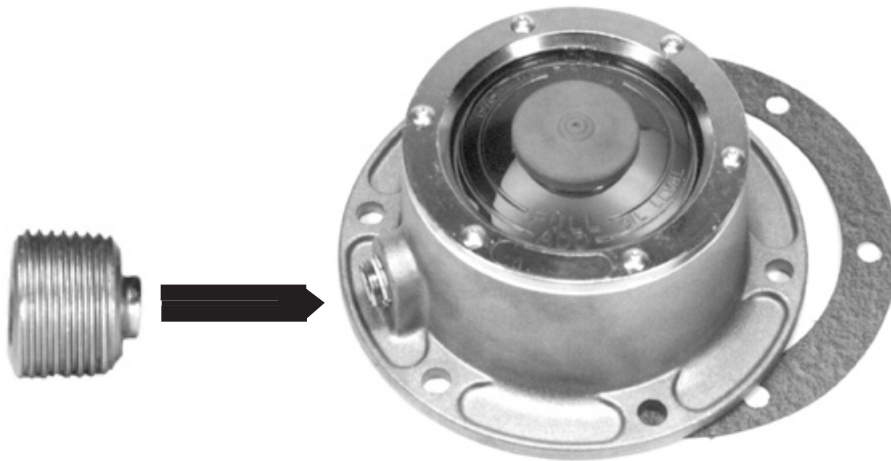

New	Notes
FS-5984	3/8" NPT Magnetic Drain Plug
	Replaces: Stemco 359-5984



New	Notes
FS-5915	3/4" Red Plug <only>. fits FS-34249
	Replaces: Stemco 359-5915



New	Notes
FS-5990	1-1/8" Red Plug <only> fits FS-34009, FS-34024 and FS-34195
	Replaces: Stemco 359-5990

Propriété exclusive de FleetSpec. Toute reproduction interdite. / Exclusive property of FleetSpec. Reproduction prohibited.

Section 10 . Accessoires de camion & remorque
 . Truck & Trailer Accessories

**Capuchons de moyeu
 Hub Caps**

New	Bolt Circle	Bolt Holes	Height	Replaces
FS-34009	5-1/2"	6 x 5/16"	2-11/16"	Stemco 343-4009 SKF 1643, 1743
FS-34009WMP	FS-34009 with Magnetic Drain Plug installed			Stemco 343-4009
FS-34009-1	Gasket for 5-1/2" bolt circle, 6 x 5/16" holes			Stemco 330-3009
FS-34024	4-1/2"	6 x 5/16"	2-5/8"	Stemco 343-4024 SKF 1612
FS-34024-1	Gasket for 4-1/2" bolt circle, 6 x 5/16" holes			Stemco 330-3024
FS-34195	6-3/4"	6 x 5/16"	3-11/16"	Stemco 343-4195 SKF 1696
FS-34195-1	Gasket for 6-3/4" bolt circle, 6 x 5/16" holes			Stemco 330-3118
FS-34249	5-1/2"	6 x 3/8"	1-13/16"	Stemco 343-4249 SKF 1613
	5-9/16"	6 x 5/16"		
FS-34249-1	Gasket <only> for FS-34249			Stemco 330-3122

FS-34009



FS-34024

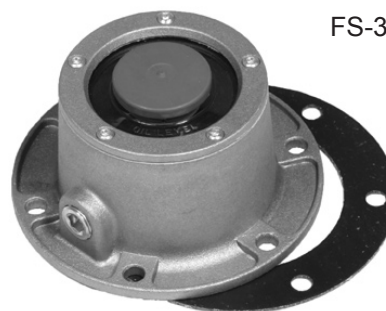

FS-34195



FS-34249

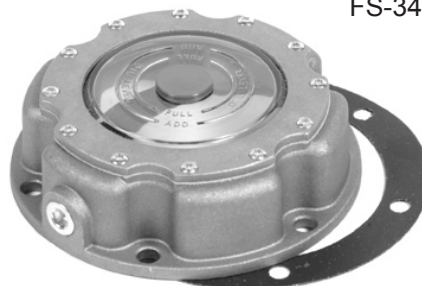

Section 10 . Accessoires de camion & remorque • Truck & Trailer Accessories

Butoirs de quai en caoutchouc Rubber Dock Bumpers

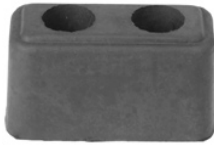

New	Notes
RDB1000	6"L x 2-3/4"W x 3"H 1/2" bolt holes on 2-1/2" centers.
Replaces: Buyers B5500 HI-V 671-1044 Jimex 610-127 Ride-Air RA2444 RPT F02173	

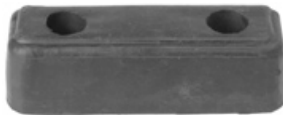

New	Notes
RDB1001	8"L x 2-1/2"W x 2-1/4"H 3/8" bolt holes on 4-1/2" centers.
Replaces: Faucher 625-6007 HI-V 671-1042 Jimex 610-007 Ride-Air RA2442 RPT F02158	



New	Notes
RDB1002	8-1/8"L x 5-1/2"W x 3-1/2"H 3/4" bolt holes on 5-1/2" centers, 3-1/8" apart.
Replaces: Faucher 625-6153 HI-V 671-1045 Jimex 612-111 Ride-Air RA2445 RPT F02156	



New	Notes
RDB1003	4-3/4"L x 3-1/8"W x 3-5/8"H 1/2" bolt holes on 2-1/2" centers.
Replaces: Faucher 625-6053 HI-V 671-1046 RPT F02155	

Section 10 · Accessoires de camion & remorque
 · Truck & Trailer Accessories

Butoirs de quai en caoutchouc
Rubber Dock Bumpers

New	Notes
RDB1004	16"L x 2-3/8"W x 2"H 3/8" bolt holes on 6-1/2" centers.
Replaces: Faucher 625-0024 Hi-V 671-1041 Jimex 610-014 Ride-Air RA2441 RPT F02159	

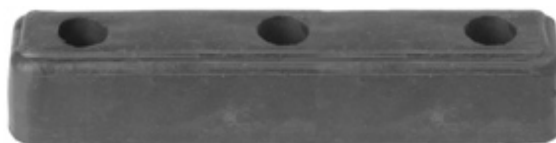

New	Notes
RDB1005	6"L x 4"W x 3-1/4"H 7/16" bolt holes on 2-1/2" centers.
Replaces: Faucher 625-6102 Hi-V 671-1043 Jimex 610-102 Ride-Air RA2443	



New	Notes
RDB1006	5-1/4"L x 3-1/2"W x 4-3/8"H 1/2" bolt holes on 3-1/2" centers.
Replaces: Trailmobile 431-1-149, Great Dane, & Utility brands	



Section 10 . Accessoires de camion & remorque • Truck & Trailer Accessories

Butoirs de quai en caoutchouc, en forme de "D" "D-Shaped" Rubber Dock Bumpers



New	Notes
RDB1020	6"L x 4"W x 3-1/2"H 3/8" holes on 3" centers.
Replaces: Faucher 625-4033 Jimex 625-106	

New	Notes
RDB1021	12"L x 4"W x 3-1/2"H
Replaces: Faucher 625-4065	

New	Notes
RDB1022	36"L x 4"W x 3-1/2"H
Replaces: Faucher 625-4139	

Cales de roues Rubber Wheel Chocks



New	Notes
RWC1000	"Pyramid" design. 7-3/4"L x 9-1/2"W x 5-5/8"H
Replaces: Hi-V 671-1047 Jimex 610-131 Ride-Air RA2400SD RPT F00155	

New	Notes
RWC1001	"Contour" design. 9-1/2"L x 6-1/2"W x 7"H
Replaces: Faucher 625-6141 Hi-V 671-1048 Ride-Air RA2401-1 RPT F00169	

Section 10 • Accessoires de camion & remorque
 • Truck & Trailer Accessories

Courroies de caoutchouc
Rubber Cargo Straps

New	Length	Qty.
FS-3063	4"	10
FS-3066	9"	10
FS-3067	15"	10
FS-3068	21"	10
FS-3070 (adjustable)	24" (Max)	10
	5 Hook-holes, spaced 6" apart	
FS-3069	31"	10
FS-3065	41"	10

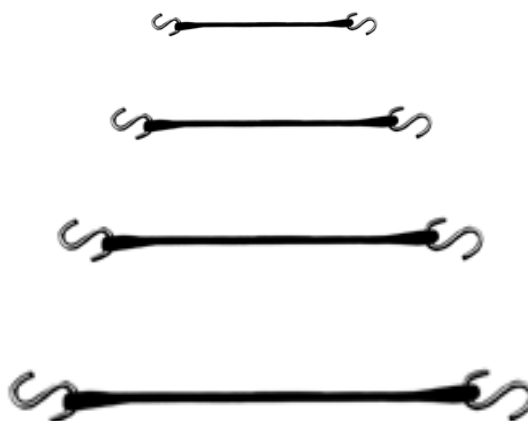

Porte-documents
Document Holders

New	Notes
FS-3220	* Corrosion resistant Aluminum construction. * Tube measures 1-5/8" dia. x 9" long. * Support mount 2-3/4" x 5-3/4"
FS-3220C	Replacement rubber End-Caps (bag of 5 pcs.)

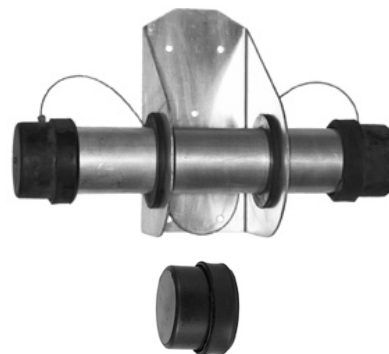

New	Notes
FS-3221	* Corrosion resistant, non-metallic construction. * Galvanized Steel spring. * "Smoked" see-thru polycarbonate cover. * Mounts by 3/16" holes on 5-1/2" centers.
Replaces: Truck-Lite 97960	
FS-3221C	Replacement Cover (with Gasket)
Replaces: Tectran 9446; Truck-Lite 97960-3	



Propriété exclusive de FleetSpec. Toute reproduction interdite. / Exclusive property of FleetSpec. Reproduction prohibited.

Section 10 . Accessoires de camion & remorque
· Truck & Trailer Accessories**Verrouillage du pivot d'attelage**
King Pin Lock

New	Notes
KPL1000	* Zinc plated Steel. * 2 Keys provided. * Available "Keyed Alike" in cases of 12 pcs.

Section 10 · Accessoires de camion & remorque
· Truck & Trailer Accessories

Notes

FleetSpec



Appendix

TERMES ET CONDITIONS

PROCÉDURE DE COMMANDE : Vos commandes peuvent être effectuées par la poste, le téléphone ou le fax.

Adresse postale : **FleetSpec**, 5857 Chemin Saint-François, St-Laurent, Québec, H4S 1B6
Téléphone : (514) 956-0111 ou sans frais : 1-888-350-FLEET (3533)
Fax : (514) 956-0782

TERMES: Net 30 jours.

CONDITIONS :

- Des intérêts sont imputables pour tout compte en souffrance.
- Tout solde impayé selon le délai entraînera le paiement sur livraison (C.O.D.) ou paiement à l'avance de toute nouvelle commande.
- Tout envoi de produits est basé sur le prix établi à Montréal.
- Les frais de transport pour toute commande excédant 3,000.00 \$, mais excluant les prix des noyaux, sont défrayés par **FleetSpec** (à l'exception des livraisons à terre-neuve et les régions nordiques).
- Les noyaux sont payables, selon les termes spécifier ci-haut.
- Tout produit en attente de réception du fournisseur sera ajouté à votre prochain envoi, sauf avis contraire.

TRANSPORT DES NOYAUX : Les clients doivent retourner les noyaux, à leurs frais, à l'adresse suivante :

FleetSpec
128 Maple Dale, Suite 101
East Farnham, Québec
J2K 4M8

TERMS & CONDITIONS

ORDERING PROCEDURES : Orders can be placed by mail, telephone or fax.

Mailing address: **FleetSpec**, 5857 Chemin Saint-François, St-Laurent, Québec, H4S 1B6
Telephone : (514) 956-0111 or toll free : 1-888-350-FLEET (3533)
Fax : (514) 956-0782

TERMS : Net 30 days.

CONDITIONS:

- A late payment charge will be added to all past due invoices.
- Any unpaid account within the stated terms is subject to a C.O.D. or C.I.A. status.
- All shipments are F.O.B. Montréal.
- Prepaid freight on orders of \$3,000.00 or more in value, excluding cores (excluding deliveries to Newfoundland & Northwest Territories).
- Cores are payable in accordance with the above terms.
- Back order items will be added to your next order, unless specified otherwise.

CORE FREIGHT : All customers will return cores (freight prepaid) to the following address :

FleetSpec
128 Maple Dale, Suite 101
East Farnham, Québec
J2K 4M8

POLITIQUE POUR LES NOYAUX

Tout client se verra octroyer une période d'un an, à partir de la date de la facturation, pour retourner les noyaux afin d'obtenir le crédit applicable. Tout produit contenu dans la banque de noyaux sera automatiquement effacé de la banque s'il n'est pas retourné à l'intérieur de la période de douze (12) mois.

Les noyaux retournés à **FleetSpec**, mais ne faisant pas l'objet d'un crédit, seront placés dans la banque de noyaux du client pour une période d'un (1) an. Après cette période, les noyaux contenus dans la banque et non utilisés lors d'achat subséquente deviendront la propriété de **FleetSpec**.

Basé sur la politique « item par item », le crédit de noyau sera appliqué en fonction de tout achat préalablement effectué.

FleetSpec peut également être intéressé par l'achat de certains types de noyaux ne figurant pas dans la banque de noyau du client, et pour lesquels un crédit ne peut être émis. Cet achat s'effectuera uniquement en fonction des besoins de **FleetSpec**.

Les noyaux reçus endommagés ou avec pièces manquantes seront susceptible de frais comme suit:

- Une pièce manquante ou défectueuse : 50% de la valeur reçu
- Plus d'une pièce manquante ou défectueuse : Aucune valeur

La valeur monétaire de tout noyau ainsi que toute charge additionnelle se négocient au moment de l'entente de vente.

Les noyaux répertoriés « endommagés » à la suite d'une inondation, d'un incendie, de surchauffe ou d'abandon dans des dépotoirs n'ont aucune valeur négociable.

CORE POLICIES

Each customer has one year from the purchase date of the finished product to return the core in order to receive the appropriate credit. Any item in the customer's core bank will then be deleted if it is not returned before the end of the twelve (12) month period.

Cores returned to **FleetSpec**, which are not eligible for core return credit, will be placed in a core bank for up to one (1) year. Cores remaining in that bank after a one (1) year period without a corresponding purchase will become the sole property of **FleetSpec**.

Based on an «item by item» policy, the core credit can be granted against the item previously purchased.

FleetSpec may also be interested in purchasing certain cores for which the customer is not entitled to a credit, following the core bank policy. Offers to purchase such cores will be on an «as needed» basis.

Cores with damaged or missing components are subject to the following percentage charge backs :

- One part damaged or missing : deduct 50% of full core value
- Cores with more than one part damaged or missing : no value

The value of any core, as well as any additional charges, are determined at the point of sale.

Cores that are classified as flood, fire, heat damaged or « junkyard cores » have no value.

GARANTIE

FleetSpec garantit que tous ses produits remanufacturés, achetés ou distribués sont sans défaut tant au niveau du matériel que de l'assemblage et ce, en fonction d'un usage normal. La politique générale de garantie de **FleetSpec** couvre une période de douze (12) mois à compter de la date de facturation, à l'exception des valves (remanufacturées) où la garantie est de douze (12) mois à compter de la date du sceau d'identification attaché à la valve.

Toute marchandise sous garantie doit nous être retournée, <<à vos frais>>, lors de votre prochain envoi de noyaux à l'adresse suivante : **FleetSpec**, 128 Maple Dale, Suite 101, East Farnham, Québec, J2K 4M8.

FleetSpec, à sa discrétion, réparera, remplacera sans frais, créditera les composantes défectueuses ou remplacera les composantes défectueuses par des pièces équivalentes, sans frais supplémentaires.

La garantie sur nos produits est annulée si :

- Les pièces ne sont pas installées selon nos spécifications
- Les pièces subissent des altérations et/ou modifications non conformes à nos spécifications sans notre approbation préalable.

Si un produit ne comporte aucune garantie ou fonctionne normalement, les options suivantes sont envisageables :

- Le produit peut vous être retourné, à vos frais
- **FleetSpec** en dispose, à sa convenance

La garantie s'applique uniquement au premier acheteur utilisateur du produit et n'est pas transférable.

La garantie offerte par **FleetSpec** ne peut être modifiée ou révisée par un employé, agent ou représentant.

La garantie ne couvre pas les frais d'installation, la main-d'œuvre, le transport, la perte de temps et tous autres frais connexes.

Le produit défectueux, couvert par la garantie, sera soit remplacé ou crédité par **FleetSpec**, à notre discrétion.

WARRANTY

FleetSpec warrants products it manufactured or supplied to be free from defects in material and workmanship under normal use and service. The overall warranty policy is for twelve (12) months from the date of invoice, except for (remanufactured) valves, where the warranty is for a twelve (12) months period, from the date of the identification tag attached to the valve.

All warranty returns must be shipped, <<Pre-Paid>>, with the next scheduled core return shipment to the following address : **FleetSpec**, 128 Maple Dale, Suite 101, East Farnham, Québec, J2K 4M8.

FleetSpec will, at our option, either repair, replace without charge, or give credit for components or parts shown to be defective or replace those defective parts by equivalent ones.

The warranty on our products is void when :

- Parts are not installed according to our specifications.
- Parts are altered or changed from originals specifications without our knowledge and consent.

If a product is determined to be non-warrantable or is found to function normally, the following options are available :

- The product may be returned to you freight « collect »
- **FleetSpec** can dispose of the part(s) at its warehouse

The warranty only applies to the first user purchaser of the product.

The warranty is offered by **FleetSpec** and therefore no employee, agent, salesman or other person has the authority to offer or make any other warranty.

The warranty does not cover charges for installation, labor, travel, consequential damages, loss of time or other incidentals.

Products found to be defective under the warranty will be rectified by credit or replacement of the part, at **FleetSpec**'s discretion.

Équivalence / Interchange

Berg à/to Bendix

PART #	FleetSpec Replacement
B12340X	FS103009N
B12341X	FS103009N
B12342X	FS102626N, FS103009N
B12344X	FS102626N, FS103009N
B12345X	FS102626N, FS103009N
B12346X	FS102626N, FS103009N
B12352X	FS101112X, FS102626N
B12360X	FS101112X, FS102626N

Kelsey Hayes à/to Bendix

PART #	FleetSpec Replacement
KH5468X	FS103009N
KH5470X	FS102626N

Midland à/to Bendix

PART #	FleetSpec Replacement
KN20541X	FS101112X, FS101622X
KN28000X	FS103009N
KN28010X	FS102626N, FS103009N
KN28011X	FS102626N, FS103009N
KN28060X	FS103009N
KN28061X	FS103009N
KN28071X	FS103010N
KN28132X	FS103009N
KN28140X	FS103010N

Sealco à/to Bendix

PART #	FleetSpec Replacement
S9125X	FS102626N, FS103009N
SA1100SX	FS102626N

Wagner à/to Bendix

PART #	FleetSpec Replacement
WA104001X	FS101112X, FS101622X
WA104003X	FS101112X, FS101622X
WA104010X	FS101112X, FS101622X
WA78882X	FS102626N, FS103009N
WA78887X	FS102626N, FS103009N
WA86473X	FS102626N
WA86477X	FS102626N
WA88802X	FS101112X, FS101622X
WA88812X	FS101112X, FS101622X
WA98730X	FS101112X, FS101622X
WA98731X	FS101112X, FS101622X
WA98732X	FS101112X, FS101622X

Bendix à/to Midland

PART #	FleetSpec Replacement
BW065104X	WA103600X
BW101112X	FSKN26000X
BW101622X	FSKN26000X
BW103009X	FSKN28140X
BW103010X	FSKN28071X
BW227661X	FSKN34070X
BW227672X	FSKN34070X
BW229434X	FSKN30300X
BW229467X	FSKN28060N
BW229500X	FSKN22100X
BW229501X	FSKN22100X
BW277446X	FSKN30300X
BW277863X	FSKN22100X
BW278898X	FSKN22100X
BW279000X	FSKN34060X
BW279180X	FSKN28140X
BW279962X	FSKN34060X
BW280243X	FSKN28132X
BW280651X	WA103600X
BW281860X	FSKN30400X
BW281865X	FSKN30300X

Équivalence / Interchange

Bendix à/to Midland (cont'd)

<u>PART #</u>	FleetSpec Replacement
BW283940X	FSKN28140X
BW286171X	FSKN22140X
BW286364X	FSKN28030X
BW286370X	FSKN28071X
BW286371X	FSKN28071X
BW287224X	FSKN28071X
BW287260X	FSKN28071X
BW287376X	B12360X
BW288063X	FSKN28030X
BW288369X	FSKN28071X
BW289182X	FSKN32040X
BW289714X	FSKN32040X

Bendix à/to Sealco

<u>PART #</u>	FleetSpec Replacement
BW102626X	SE110415X
BW103009X	SE110415X
BW103109X	SE110415X
BW228500X	SE110200X
BW281865X	SE110170X
BW287375X	SE110170X
BW287376X	SE110170X
RE-4	SEA1000SX
RE-6	SE110205X
SR-2	SE110170X

Berg à/to Midland

<u>PART #</u>	FleetSpec Replacement
11661	WA103600X
11675	FSKN30300X
B12345X	WA103600X
B12346X	FSKN28500N
B12350X	FSKN30400X
B12360X	FSKN26000X

Berg à/to Sealco

<u>PART #</u>	FleetSpec Replacement
11675	SEA1000SX
11675	SE110470X
B12341X	SE110410X
B12343X	SE110415X
B12345X	SE110415X
B12346X	SE110410X
B12360X	SE110170X
B12361X	SE110170X
WA99036X	SE110200

Midland à/to Midland

<u>PART #</u>	FleetSpec Replacement
B12360X	FSKN26000X
KN28150X	FSKN26000X
KN28160X	FSKN28500X
KN30010X	FSKN30300X

Sealco à/to Midland

<u>PART #</u>	FleetSpec Replacement
S3100X	FSKN28500N
S9125X	FSKN28500N
S110139X	WA103600X
S110147X	FSKN26000X
S110171X	FSKN26000X
S110180X	FSKN26000X
S110190X	FSKN26000X
S110200X	FSKN30300X
S110205X	FSKN30400X
S110230X	FSKN26000X
SA1000X	FSKN30300X
SA1100X	WA103600X

Équivalence / Interchange

Wagner à/to Midland

PART #	FleetSpec Replacement
WA104001X	FSKN26000X
WA104002X	FSKN26000X
WA104003X	FSKN26000X
WA104010X	FSKN26010X
WA37411X	FSKN30300X
WA71890X	FSKN30300X
WA71891X	FSKN30200X
WA78880X	FSKN28500N
WA78882X	FSKN28510N
WA78886X	FSKN28500N
WA78887X	FSKN28520N
WA78889X	FSKN28510N
WA80070X	FSKN28500N
WA83335X	FSKN26000X, B12360X
WA83336X	FSKN26000X, B12360X
WA86310X	FSKN28500N
WA86311X	FSKN28500N
WA86313X	FSKN28510N
WA86314X	FSKN28510N
WA86318X	FSKN28510N
WA88802X	FSKN26000X
WA88812X	FSKN26000X
WA98730X	FSKN26000X
WA99036X	FSKN30400X

Kelsey Hayes à/to Midland

PART #	FleetSpec Replacement
KH5454X	WA103600X

Midland à/to Sealco

PART #	FleetSpec Replacement
WA30010X	SE110200X
KN26000X	SE110191X
KN26010X	SE110191X
KN28510X	SE110410X
KN30000X	SEA1000SX
KN30100X	SEA1000SX, SE110200X
KN30200X	SE110267X, SE110338X
KN30300X	SEA1000SX, SE110200X
KN30400X	SEA1000SX, SE110200X
RG-2	SE110410X
RT-4	SE110191X

 **FleetSpec**



List numérique
Index

List numérique / Index

Numero de pièce Part Number	Description	Page
4005001010X	Wabco Trailer ECU / MODULATOR Assy.	118
4005001020X	Wabco Trailer ECU / MODULATOR Assy.	119
4005001030X	Wabco Trailer ECU / MODULATOR Assy.	119
4005001040X	Wabco Trailer ECU / MODULATOR Assy.	118
4005001050X	Wabco Trailer ECU / MODULATOR Assy.	119
4008500530X	Wabco Trailer ECU / MODULATOR Assy.	117
4008500540X	Wabco Tractor ABS MODULATOR	117
4008506020X	Wabco Trailer ABS Dual MODULATOR	119
4721707910X	Wabco ABS/ATC Valve	115
4721707960X	Wabco ABS/ATC Valve	115
4721707970X	Wabco ABS/ATC Valve	115
4721950040X	Wabco Tractor ABS MODULATOR	117
4721950050X	Wabco Tractor ABS MODULATOR	117
4721950100X	Wabco Tractor ABS MODULATOR	117
4721950170X	Wabco Tractor ABS MODULATOR	117
4721950180X	Wabco Tractor ABS MODULATOR	117
4721950230X	Wabco Trailer ABS MODULATOR	122
4721950260X	Wabco Trailer ABS MODULATOR	122
4721950270X	Wabco Trailer ABS MODULATOR	122
4721950320X	Wabco Trailer ABS MODULATOR	122
4721950330X	Wabco Trailer ABS MODULATOR	118, 122
4721950520X	Wabco Tractor ABS MODULATOR	117
4721950670X	Wabco Tractor ABS MODULATOR	117
4721950740X	Wabco ABS MODULATOR, 24V	113, 115, 117
4721950750X	Wabco ABS MODULATOR, 24V	113, 115, 117
4721950760X	Wabco ABS MODULATOR	113, 115, 116
4721950770X	Wabco ABS MODULATOR	113, 115, 116
4721950780X	Wabco ABS MODULATOR	113, 115
4721950790X	Wabco ABS MODULATOR	113, 115
4721950800X	Wabco ABS MODULATOR	113, 116
4721950810X	Wabco ABS MODULATOR	113, 116
4721950820X	Wabco ABS MODULATOR	113, 115
4721950830X	Wabco ABS MODULATOR	113, 115
4721950840X	Wabco ABS MODULATOR	117
4721950850X	Wabco ABS MODULATOR	117
4721950920X	Wabco Tractor ABS MODULATOR	117
4721950930X	Wabco Tractor ABS MODULATOR	117
4721950940X	Wabco Tractor ABS MODULATOR	117
4721950950X	Wabco Tractor ABS MODULATOR	117
4721950960X	Wabco Tractor ABS MODULATOR	117
4725000110X	Wabco Trailer ECU / MODULATOR Assy.	120
4725000120X	Wabco Trailer ECU / MODULATOR Assy.	121
4725000130X	Wabco Trailer ECU / MODULATOR Assy.	121
4725000210X	Wabco Trailer ECU / MODULATOR Assy.	120
4725001000X	Wabco Tractor ABS VALVE PACKAGE (Rear)	113
4725001010X	Wabco Tractor ABS VALVE PACKAGE (Rear)	113
4725001020X	Wabco Tractor ABS VALVE PACKAGE (Rear)	113
4725001030X	Wabco Tractor ABS VALVE PACKAGE (Rear)	113
4725001200X	Wabco Tractor ABS VALVE PACKAGE (Rear)	113
4725001210X	Wabco Tractor ABS VALVE PACKAGE (Rear)	113
4725001220X	Wabco Tractor ABS VALVE PACKAGE (Rear)	113
4725001230X	Wabco Tractor ABS VALVE PACKAGE (Rear)	113

List numérique / Index

Numero de pièce Part Number	Description	Page
4725001240X	Wabco Tractor ABS VALVE PACKAGE (Rear)	113
4725001250X	Wabco Tractor ABS VALVE PACKAGE (Rear)	113
4725001320X	Wabco Tractor ABS VALVE PACKAGE (Rear)	113
4725002030X	Wabco Tractor ABS/ATC VALVE PACKAGE (Rear)	115
4725002200X	Wabco Tractor ABS/ATC VALVE PACKAGE (Rear)	115
4725002210X	Wabco Tractor ABS/ATC VALVE PACKAGE (Rear)	115
4725002220X	Wabco Tractor ABS/ATC VALVE PACKAGE (Rear)	115
4725002230X	Wabco Tractor ABS/ATC VALVE PACKAGE (Rear)	115
4725002240X	Wabco Tractor ABS/ATC VALVE PACKAGE (Rear)	115
4725002250X	Wabco Tractor ABS/ATC VALVE PACKAGE (Rear)	115
4725002260X	Wabco Tractor ABS/ATC VALVE PACKAGE (Rear)	115
4725002320X	Wabco Tractor ABS/ATC VALVE PACKAGE (Rear)	115
4725003000X	Wabco Tractor ABS VALVE PACKAGE (Front)	116
4725003010X	Wabco Tractor ABS VALVE PACKAGE (Front)	116
4725003020X	Wabco Tractor ABS VALVE PACKAGE (Front)	116
4725003200X	Wabco Tractor ABS VALVE PACKAGE (Front)	116
4725003210X	Wabco Tractor ABS VALVE PACKAGE (Front)	116
4725003220X	Wabco Tractor ABS VALVE PACKAGE (Front)	116
4725004030X	Wabco Tractor ABS VALVE PACKAGE (Rear)	113
4725004050X	Wabco Tractor ABS VALVE PACKAGE (Rear)	113
4725004200X	Wabco Tractor ABS VALVE PACKAGE (Rear)	113
4725004210X	Wabco Tractor ABS VALVE PACKAGE (Rear)	113
4725004220X	Wabco Tractor ABS VALVE PACKAGE (Rear)	113
4725004230X	Wabco Tractor ABS VALVE PACKAGE (Rear)	113
4725004240X	Wabco Tractor ABS VALVE PACKAGE (Rear)	113
4725004250X	Wabco Tractor ABS VALVE PACKAGE (Rear)	113
4725005200X	Wabco Tractor ABS/ATC VALVE PACKAGE (Rear)	115
4725005210X	Wabco Tractor ABS/ATC VALVE PACKAGE (Rear)	115
4725005220X	Wabco Tractor ABS/ATC VALVE PACKAGE (Rear)	115
4725005230X	Wabco Tractor ABS/ATC VALVE PACKAGE (Rear)	115
4725005240X	Wabco Tractor ABS/ATC VALVE PACKAGE (Rear)	115
4725005250X	Wabco Tractor ABS/ATC VALVE PACKAGE (Rear)	115
9730110210X	Wabco ABS RELAY Valve	113
9730110220X	Wabco ABS RELAY Valve	113
9730110230X	Wabco ABS RELAY Valve	113
9730110240X	Wabco ABS RELAY Valve	113
9730110250X	Wabco ABS RELAY Valve (for ATC)	115
9730110260X	Wabco ABS RELAY Valve (for ATC)	115
9730110270X	Wabco ABS RELAY Valve (for ATC)	115
9730110280X	Wabco ABS RELAY Valve (for ATC)	115
9735001040X	Wabco ABS QUICK RELEASE Valve	116
9735001050X	Wabco ABS QUICK RELEASE Valve	116
9735001060X	Wabco ABS QUICK RELEASE Valve	116
ABS0001	ABS Sensor Spring CLIP	105, 106
ABS0002	ABS Sensor Spring CLIP	105
ABS090-0.3M	ABS SENSOR - Right Angle	104
ABS090-0.3MBEN	ABS SENSOR - Right Angle (for Bendix)	106
ABS090-0.5M	ABS SENSOR - Right Angle	104
ABS090-0.9M	ABS SENSOR - Right Angle	104
ABS090-1.0MBEN	ABS SENSOR - Right Angle (for Bendix)	106
ABS090-1.5M	ABS SENSOR - Right Angle	104
ABS090-1.5MBEN	ABS SENSOR - Right Angle (for Bendix)	106

List numérique / Index

Numero de pièce Part Number	Description	Page
ABS090-1.8M	ABS SENSOR - Right Angle	104
ABS090-1.9MBEN	ABS SENSOR - Right Angle (for Bendix)	106
ABS090-2.0M	ABS SENSOR - Right Angle	104
ABS090-2.0MBEN	ABS SENSOR - Right Angle (for Bendix)	106
ABS180-0.4MDB	ABS Mini SENSOR - Straight	104
ABS180-0.6M	ABS SENSOR - Straight	104
ABS180-1.0MBEN	ABS SENSOR - Straight (for Bendix)	106
ABS180-1.7MBEN	ABS SENSOR - Straight (for Bendix)	106
ABS180-1.8M65MM	ABS SENSOR - Straight	104
ABS180-1.8M79MM	ABS SENSOR - Straight	104
ABS180-1.9MBEN	ABS SENSOR - Straight (for Bendix)	106
ABS180-2.0M	ABS SENSOR - Straight	104
ABS180-2.0MBEN	ABS SENSOR - Straight (for Bendix)	106
ABSE090-1.8M	ABS Sensor EXTENSION Cable	105
ABSE090-3.0M	ABS Sensor EXTENSION Cable	105
ABSE090-5.0M	ABS Sensor EXTENSION Cable	105
ABSE180-1.5M	ABS Sensor EXTENSION Cable	105
ABSE180-2.0M	ABS Sensor EXTENSION Cable	105
ABSE180-2.5M	ABS Sensor EXTENSION Cable	105
ABSE180-3.0M	ABS Sensor EXTENSION Cable	105
ABSE180-3.5M	ABS Sensor EXTENSION Cable	105
AK00025N	SHUTTLE Valve, 1/4" NPT	138
AK02062N	2:1 Ratio REGULATOR	138
AK12391N	4-Way Single SOLENOID Valve, with manual o/ride	134, 145
AK12392MR	5-Port, 2-Position PUSH/PULL	134
AK12392N	4-Way Single SOLENOID Valve, with manual o/ride	134, 145
AK12392PR	5-Port, 2-Position PUSH/PULL, Air Reset	135
AK12392S	Solenoid for AK12391N, AK19392N	138
AK12392SP	Spool for AK12391N, 92N	138
AK12393N	3-Port, 2-Position PUSH/PULL, Air Reset	135
AK12394N	3-Port, 2-Position Air Pilot, Spring Return	135, 145
AK12394-1/4	3-Port, 2-Position Air Pilot, Spring Return (1/4")	136
AK12395N	3-Port, 2-Position PUSH/PULL	136
AK12396N	5-Port, 2-Position Air Pilot, Spring Return	136
AK12401N	3-Port, 2-Position PUSH/PULL, Air Reset	137, 146
AK12402N	Control Valve, manual or Air Reset	137
AK12403N	Control Valve, manual reset	137
AL364040X	Haldex ABS RELAY Valve	111
AL364041X	Haldex ABS RELAY Valve	111
AL364045X	Haldex ABS RELAY Valve	111
AL430611X	Haldex FFABS	110
AL430614X	Haldex FFABS	110
B12343N	RELAY Valve, New	76
B12343X	Berg RELAY Valve	76
B12347X	Berg RELAY Valve	76
B12350X	Berg RELAY Valve	76
B12352N	S.E.R.V. Valve, New	77
B12352X	Berg S.E.R.V. Valve	77
B12360X	Berg TASK Valve	77
B12361X	Berg TASK Valve	77
F400-D10140	SLACK ADJUSTER, w/inst kit, Haldex style	22
F400-D10141	SLACK ADJUSTER, w/inst kit, Haldex style	22

Propriété exclusive de FleetSpec. Toute reproduction interdite. / Exclusive property of FleetSpec. Reproduction prohibited.

List numérique / Index

Numero de pièce Part Number	Description	Page
F400-D10143	SLACK ADJUSTER, w/inst kit, Haldex style	22
F400-D10144	SLACK ADJUSTER, w/inst kit, Haldex style	22
F400-D10155	SLACK ADJUSTER, w/inst kit, Haldex style	22
F400-D10211	SLACK ADJUSTER, w/inst kit, Haldex style	22
F400-D10212	SLACK ADJUSTER, w/inst kit, Haldex style	22
F400-D10215	SLACK ADJUSTER, w/inst kit, Haldex style	22
F400-D10216	SLACK ADJUSTER, w/inst kit, Haldex style	22
F400-D10305	SLACK ADJUSTER, w/inst kit, Haldex style	22
F400-D10306	SLACK ADJUSTER, w/inst kit, Haldex style	22
F42710553	INSTALLATION Kit	23
F42710554	INSTALLATION Kit	23
F42710558	STUD Kit	23
F42710563	INSTALLATION Kit	23
F42710566	INSTALLATION Kit	23
F44310318K	STUD Kit	23
F45210125	BUSHING, Rectangular (plastic)	23
FS065040X	Bendix AD-4 Air DRYER, 24V	33
FS065040XNB	Bendix AD-4 Air DRYER, 24V (no bracket)	33
FS065041X	Bendix AD-4 Air DRYER, 12V	33
FS065041XNB	Bendix AD-4 Air DRYER, 12V (no bracket)	33
FS065043X	Bendix AD-4 COVER, 24V - 120W Single terminal	33
FS065044X	Bendix AD-4 COVER, 12V	33
FS065066N	QR-1 Non-metallic, 1/2" Supply, New	58
FS065067N	QR-1 Non-metallic, 3/8" Supply, New	58
FS065089X	Bendix AD-4 Air DRYER 24V - 120W	33
FS065089XNB	Bendix AD-4 Air DRYER 24V - 120W (no bracket)	33
FS065090X	Bendix AD-4 COVER, 24V, 120W dbl Terminal	33
FS065104N	R-12 RELAY Valve, New	60
FS065125N	R-12H RELAY Valve, New	62
FS065125X	Bendix R-12H RELAY Valve	62
FS065145N	BP-R1 Bobtail RELAY Valve	45
FS065146N	BP-R1 Bobtail RELAY Valve	45
FS065154X	Bendix LQ-5 Bobtail RATIO Valve	50
FS065156X	Bendix MV-3 Control MODULE	53
FS065157X	Bendix MV-3 Control MODULE	53
FS065175N	SLACK ADJUSTER, Bendix style	20
FS065179N	SLACK ADJUSTER, Bendix style	20
FS065186X	Bendix MV-3 Control MODULE	53
FS065206N	R-12 RELAY Valve	61
FS065206X	Bendix R-12 RELAY Valve	61
FS065208X	Bendix MV-3 Control MODULE	53
FS065224AXNB	Bendix AD-9 Air DRYER New style cover, 24V	35
FS065224N	AD-9 Air DRYER, 24V, New	35
FS065224N100W	AD-9 Air DRYER, 24V, 100W, New	35
FS065224NNB	AD-9 Air DRYER, 24V, New (no bracket)	35
FS065224NNB100W	AD-9 Air DRYER, 24V, 100W (no bracket)	35
FS065224X	Bendix AD-9 Air DRYER, 24V	35
FS065224XNB	Bendix AD-9 Air DRYER, 24V (no bracket)	35
FS065224XNB100W	Bendix AD-9 Air DRYER, 24V (no bracket)	35
FS065225N	AD-9 Air DRYER, 12V, New	35
FS065225NNB	AD-9 Air DRYER, 12V, New (no bracket)	35
FS065225NPF	Pure Filter AD-9 Style DRYER 12V, New	34

Propriété exclusive de FleetSpec. Toute reproduction interdite. / Exclusive property of FleetSpec. Reproduction prohibited.

List numérique / Index

Numero de pièce Part Number	Description	Page
FS065227X	Use FS109688X	
FS065228XNB	Bendix AD-9-EP Air DRYER, 12V (no bracket)	35
FS065229N	AD-9 COVER, 3/4" ports, 24V, 75W	36
FS065229X	Bendix AD-9 COVER, 24V	36
FS065230X	Bendix AD-9 COVER, 3/4" ports, 12V	36
FS065231N	AD-9 COVER, 1/2" ports, 12V, 75W	36
FS065231X	Bendix AD-9 COVER, 1/2" ports, 12V	36
FS065243XNB	Bendix AD-9-EP Air DRYER, 12V (no bracket)	35
FS065247N	SLACK ADJUSTER, Bendix style	20
FS065248X	Bendix MV-3 Control MODULE	53
FS065303N	R-12 RELAY Valve, New	61
FS065313X	Bendix E-12 Dual FOOT Valve	49
FS065337X	Bendix M-21 ABS Modulator Valve	108
FS065344N	SLACK ADJUSTER, Bendix style	20
FS065395X	Bendix E-14 Dual FOOT Valve	49
FS065430X	Bendix R-14V&H Relay valve - Reman	63
FS065437N	SR-5 SPRING BRAKE Valve, New	68
FS065438X	Use FS109616X	
FS065439N	SR-5 SPRING BRAKE Valve, New	68
FS065439X	Use FS109617X	
FS065440X	Use FS109618X	
FS065451N	RE-6NC RELAY EMERGENCY Valve - New	65
FS065451X	Bendix RE-6NC RELAY EMERGENCY Valve, reman	65
FS065476N	R-12P RELAY Valve	62
FS065499X	Bendix AD-9 12v 1/2" DLU Purge	35
FS065499XNB	Bendix AD-9 12v 1/2" DLU Purge (No brkt)	35
FS065523X	Bendix MV-3 Control MODULE	53
FS065612N	AD-IP DRYER, 12V, New	28
FS065613N	AD-IP DRYER, 24V, New	28
FS065624N	AD-IP CARTRIDGE, New	28
FS065647XNB	Bendix AD-9 DRYER, 12V, Drop In	35
FS065661N	PP-DC CONTROL Valve, New	56
FS065661X	Bendix PP-DC CONTROL Valve	56
FS065691X	Use FS109991X	
FS065700N	SLACK ADJUSTER, Bendix style	20
FS065706N	TP-3DC PROTECTION Valve - New	72
FS065706X	Bendix TP-3DC PROTECTION Valve - Reman	72
FS101100X	Bendix E-10 Dual FOOT Valve	49
FS101112N	SR-4 SPRING BRAKE Valve, New	68
FS101112X	Bendix SR-4 SPRING BRAKE Valve	68
FS101333N	R-10 RELAY Valve, New	60
FS101437X	Bendix MV-2 Control MODULE	51
FS101479X	Bendix PP-7 CONTROL Valve	55
FS101569X	Bendix MV-2 SPOOL Assembly (red)	51
FS101570X	Bendix MV-2 SPOOL Assembly (yellow)	51
FS101622N	SR-4 SPRING BRAKE Valve, New	68
FS101622X	Bendix SR-4 SPRING BRAKE Valve	68
FS101818X	Bendix E-7 Dual FOOT Valve	48
FS101860X	Bendix TC-7 TRAILER CONTROL Valve	71
FS101900N	AD-2 Desiccant CARTRIDGE, New	32
FS101900X	Bendix AD-2 Desiccant CARTRIDGE	32
FS101930X	R-8 RELAY Valve, Metric	59

List numérique / Index

Numero de pièce Part Number	Description	Page
FS102423N	HANDLE for TC-7	71
FS102626N	R-12 RELAY Valve, New	60
FS102657N	THERMOSTAT Kit, AD-2 -4	32, 33
FS102707X	Bendix TC-7 TRAILER CONTROL Valve	71
FS102761N	SR-2 Trailer SPRING BRAKE Valve	67
FS102761X	Bendix SR-2 SPRING BRAKE Valve	67
FS103009N	R-12H RELAY Valve, New	62
FS103010N	R-14H RELAY Valve, New	63
FS103028N	R-14 RELAY Valve, New	63
FS103061N	SR-2 Trailer SPRING BRAKE Valve	67
FS103061X	Bendix SR-2 SPRING BRAKE Valve	67
FS103081N	R-7 Modulating RELAY Valve	59
FS103253X	Bendix AD-2 COVER, 24V, 120W	32
FS103818N	AD-4 Purge Valve KIT	33
FS103980N	AD-4 End Cover KIT	33
FS104308X	Bendix E-6 Dual Circuit FOOT Valve	48
FS104358N	AD-4 Desiccant CARTRIDGE, New	33
FS104358X	Bendix AD-4 Desiccant CARTRIDGE	33
FS104561X	Bendix R-12 RELAY Valve	60
FS104598X	Bendix BP-1 PROPORTIONING Valve	45
FS106284X	Bendix BP-1 PROPORTIONING Valve	45
FS106941X	Bendix TP-5 TRACTOR PROTECTION Valve	73
FS107158N	"Easy-On" Straight YOKE Kit	10,20
FS107539X	Bendix SR-4 SPRING BRAKE Valve	68
FS107695N	AD-9 Mounting BRACKET Kit	33, 37
FS107794N	AD-9 Desiccant CARTRIDGE, New	36
FS107794NPF	Pure Filter Dessicant Cartridge - New	34
FS107794X	Bendix AD-9 Desiccant CARTRIDGE	36
FS107794XPF	Pure Filter Dessicant Cartridge - Reman	34
FS107796N	Use FS107794N	
FS107798N	Use FS5005037N	
FS107799N	AD-9 CHECK VALVE assy, 3/4" Del, New	37
FS107800N	AD-9 CHECK VALVE assy, 1/2" Del, New	37
FS108076X	Bendix SR-4 SPRING BRAKE Valve	68
FS108709N	RV-1 Pressure Reducing Valve	66
FS109264X	Use FS065476N	
FS109477X	Bendix AD-IP DRYER, 12V	28
FS109477XNB	Bendix AD-IP DRYER, 12V (no bracket)	28
FS109478XNB	Bendix AD-IP DRYER, 24V (no bracket)	28
FS109493X	Bendix AD-IP Desiccant CARTRIDGE	28
FS109494N	AD-IP Check valve KIT	29
FS109495N	AD-IP -IS -SP THERMOSTAT Kit (12 volts)	29, 30, 31
FS109496N	AD-IP -IS -SP THERMOSTAT Kit (24 volts)	29, 30, 31
FS109498N	AD-IP Cartridge BOLT Kit	29
FS109578N	AD-9 THERMOSTAT Kit (12 volt, 75 watt)	37
FS109579N	AD-9 THERMOSTAT Kit (24 volt, 75 watt)	37
FS109615X	Use FS065437N	
FS109616X	Bendix SR-5 SPRING BRAKE Valve	68
FS109617X	Use FS065437N	
FS109618X	Bendix SR-5 SPRING BRAKE Valve	68
FS109685AXNB	Bendix AD-9 DRYER, 12V, New Style Cover	35
FS109685X	Bendix AD-9 DRYER, 12V	35

Propriété exclusive de FleetSpec. Toute reproduction interdite. / Exclusive property of FleetSpec. Reproduction prohibited.

List numérique / Index

Numero de pièce Part Number	Description	Page
FS109685XNB	Bendix AD-9 DRYER, 12V (no bracket)	35
FS109685XPF	Pure Filter AD-9 Style DRYER 12V, Reman	34
FS109687XNB	Bendix AD-9 DRYER (no bracket)	35
FS109688XNB	Bendix AD-9EP DRYER 24V	35
FS109869N	AD-IP -SP -9 & Wabco Electrical CONNECTOR	29, 31, 37, 39
FS109871N	Use FS109869N	
FS109991X	Bendix AD-SP DRYER, 12V	31
FS109992X	Bendix AD-SP DRYER, 24V	31
FS-11034	3/8" PT SAFETY Valve	39, 102
FS-11209	One-Way CHECK Valve 3/8"	78, 102
FS-11210	One-Way CHECK Valve 1/2"	78, 102
FS112399N	AD-9 Exhaust COVER	36
FS-12387	Pressure REGULATOR 3/8" (Without Gauge)	174
FS-12388	Pressure REGULATOR 3/8" (Reverse Flow)	152
FS-12389	Pressure REGULATOR 3/8" (Without Gauge)	174
FS-12390	Pressure REGULATOR 3/8" (Reverse Flow)	152
FS-12390oe	Pressure REGULATOR 3/8" (Reverse Flow)	152
FS-12391B	Tailgate Air CONTROL Valve, New	173
FS-12392	Pressure REGULATOR 3/8"	152
FS-12393	Pressure REGULATOR 1/4"	152
FS131081N	ST-4 SAFETY Valve 250PSI, New	70
FS205105N	ST-1 Adjustable SAFETY Valve, New	32, 33, 70
FS225892N	TW-3 Control Valve	75
FS225892X	Bendix TW-3 CONTROL Valve	75
FS227661X	Bendix TP-2 Tractor PROTECTION Valve	72
FS227672X	Bendix TP-2 Tractor PROTECTION Valve	72
FS228600N	SL-4 Stop Lamp SWITCH, New	66
FS228750N	LP-3 Low Pressure SWITCH, New	50
FS229434X	Bendix RE-4 RELAY Valve	64
FS229505N	LQ-2 LIMITING & QUICK RELEASE Valve, New	50
FS229507N	LQ-2 LIMITING & QUICK RELEASE Valve, New	50
FS229509N	LQ-2 LIMITING & QUICK RELEASE Valve, New	50
FS229635N	TW-1 CONTROL Valve, New	74
FS229813N	QR-1 QUICK RELEASE, 3/8-1/4, New	58
FS229859N	QR-1 QUICK RELEASE, 3/8-3/8, New	58
FS229860N	QR-1 QUICK RELEASE, 1/2-3/8, New	58
FS236241N	TW-4 KNOB Kit	75
FS236577N	D-2 Mounting GASKET	46
FS240272N	PP-1 KNOB Kit 3/8" shaft	55
FS241866N	PP-1 KNOB Kit 3/8" shaft	55
FS276270N	TC-2 TRAILER Valve	71
FS276270X	Bendix TC-2 TRAILER Valve	71
FS276272N	TC-2 TRAILER Valve	71
FS276272X	Bendix TC-2 TRAILER Valve	71
FS276462X	Bendix PP-2 CONTROL Valve	54
FS276566N	PP-1 CONTROL Valve	54
FS276567N	PP-1 CONTROL Valve	54
FS276635N	TW-4 CONTROL Valve, New	75
FS277144N	RV-1 PRESSURE REDUCING Valve, New	66
FS277144X	Bendix RV-1 PRESSURE REDUCING Valve	66
FS277147N	PR-2 PRESSURE PROTECTION Valve, New	57
FS277148N	PR-2 PRESSURE PROTECTION Valve, New	57

List numérique / Index

Numero de pièce Part Number	Description	Page
FS277214N	RV-1 PRESSURE REDUCING Valve, New	66
FS277214X	Bendix RV-1 PRESSURE REDUCING Valve	66
FS277227N	PR-2 PRESSURE PROTECTION Valve, New	57
FS277340X	Bendix TR-2 INVERSION valve	74
FS277863N	E-3 FOOT Valve, New	47
FS277863X	Bendix E-3 FOOT Valve	47
FS278595X	Bendix DC-4 DOUBLE CHECK valve	45
FS278596X	Bendix DC-4 DOUBLE CHECK valve	45
FS278597X	Bendix DC-4 DOUBLE CHECK valve	45
FS278598X	Bendix DC-4 DOUBLE CHECK valve	45
FS278614N	DC-4 DOUBLE CHECK Valve, New	45
FS278615N	DC-4 DOUBLE CHECK Valve, New	45
FS278825N	SV-1 SYNCHRONIZING Valve, New	71
FS278998X	Bendix E-3 FOOT Valve	47
FS279000N	TP-3 TRACTOR PROTECTION Valve, New	72
FS279180N	R-6 RELAY Valve, New	59
FS279416N	LP-3 Low Pressure SWITCH, New	50
FS279692X	Bendix TP-3 TRACTOR PROTECTION Valve	72
FS279750X	Bendix E-4 Dual FOOT Valve	47
FS279787X	Bendix PP-3 CONTROL Valve	54
FS279950X	Bendix E-5 FOOT Valve	47
FS279952N	R-6 RELAY Valve	59
FS279952X	Bendix R-6 RELAY Valve	59
FS280454X	Bendix PP-2 CONTROL Valve	54
FS280758N	TR-3 INVERSION valve, New	74
FS280758X	Bendix TR-3 INVERSION valve	74
FS280905X	Bendix TW-2 Lever Operated CONTROL Valve	74
FS280995X	Bendix PP-1 CONTROL Valve	54
FS281318N	TR-3 INVERSION valve, New	74
FS281318X	Bendix TR-3 INVERSION valve	74
FS281459N	TR-3 INVERSION valve, New	74
FS281459X	Bendix TR-3 INVERSION valve	74
FS281587X	Bendix PP-1 CONTROL Valve	54
FS281860X	Bendix RE-6 RELAY EMERGENCY Valve	64
FS281865N	RE-6 RELAY EMERGENCY Valve, New	64
FS281923N	DV-2 DRAIN Valve, New	46
FS281924N	DV-2 DRAIN Valve, New	46
FS282472N	SV-1 SYNCHRONIZING Valve, New	71
FS282472X	Bendix SV-1 Synchronizing Valve, Reman	71
FS282499X	Bendix PP-1 CONTROL Valve	54
FS283700X	Bendix SV-1 SYNCHRONIZING Valve	71
FS283940N	R-6 RELAY Valve, New	59
FS283940X	Bendix R-6 RELAY Valve	59
FS284142N	ST-3 SAFETY Valve 150 PSI, New	32, 33, 70
FS284358N	D-2 Hi-Temp / Waterproof GOVERNOR, New	46
FS284412N	DV-2 DRAIN Valve, Heated 12V, New	46
FS284760X	Bendix E-7 FOOT Valve	48
FS284795N	DV-2 DRAIN Valve, Heated 12V, New	46
FS284818X	Bendix DV-2 DRAIN Valve, Heated 24V	46
FS286171N	E-6 Dual Circuit FOOT Valve, New	48
FS286211X	Bendix RD-3 CONTROL Valve	65
FS286364N	SR-1 SPRING BRAKE Valve, New	67

Propriété exclusive de FleetSpec. Toute reproduction interdite. / Exclusive property of FleetSpec. Reproduction prohibited.

List numérique / Index

Numero de pièce Part Number	Description	Page
FS286364X	Bendix SR-1 SPRING BRAKE Valve	67
FS286370N	R-8 RELAY Valve, New	59
FS286460N	PR-3 PRESSURE PROTECTION Valve, New	57
FS286500N	PR-4 PRESSURE PROTECTION Valve, New	57
FS286774X	Bendix E-7 Dual FOOT Valve	48
FS286873X	Bendix AD-2 PURGE Valve	32
FS286875X	Bendix AD-2 COVER, 12V	32
FS286876X	Bendix AD-2 COVER, 24V	32
FS286934X	Bendix AD-2 Air DRYER 12V	32
FS286936X	Bendix AD-2 Air DRYER 24V	32
FS286961X	Bendix AD-2 Air DRYER 24V	32
FS287053N	AD-2 Purge Valve KIT	32
FS287114N	R-8P Pilot RELAY Valve	60
FS287114X	Bendix R-8P Pilot RELAY Valve	60
FS287238X	Bendix PP-8 CONTROL Valve	55
FS287376X	Bendix SR-2 SPRING BRAKE Valve	67
FS287411X	Bendix E-7 Dual FOOT Valve	48
FS287417X	Bendix PP-1 CONTROL Valve	54
FS287418X	Bendix PP-8 CONTROL Valve	55
FS287600X	Bendix PP-1 CONTROL Valve	54
FS287637X	Bendix PP-1 CONTROL Valve	54
FS288239N	PP-7 CONTROL Valve, New	55
FS288240X	Bendix PP-7 CONTROL Valve	55
FS288241X	Bendix PP-7 CONTROL Valve	55
FS288242X	Bendix PP-7 CONTROL Valve	55
FS288267X	Bendix E-7 Dual FOOT Valve	48
FS288301X	Bendix TP-4 TRACTOR PROTECTION Valve	73
FS288323N	PR-4 PRESSURE PROTECTION Valve, New	57
FS288323X	Bendix PR-4 PRESSURE PROTECTION Valve	57
FS288369N	R-8 RELAY Valve, New	59
FS288383X	Bendix E-7 FOOT Valve	48
FS288497X	Bendix SR-2 SPRING BRAKE Valve	67
FS288605N	TP-5 TRACTOR PROTECTION Valve, New	73
FS288605X	Bendix TP-5 TRACTOR PROTECTION Valve	73
FS288719X	Bendix AD-2 Air DRYER 24V	32
FS288746X	Bendix PP-3 CONTROL Valve	54
FS288755X	Bendix R-8 RELAY Valve	59
FS289144N	LQ-4 RATIO Valve, New	50
FS289144X	Bendix LQ-4 RATIO Valve	50
FS289182X	Bendix QR-1C QUICK RELEASE Valve	58
FS289253X	Bendix TP-5 TRACTOR PROTECTION Valve	73
FS289477X	Bendix PP-3 CONTROL Valve	54
FS289512X	Bendix PP-3 CONTROL Valve	54
FS289714N	QR-1C QUICK RELEASE Valve, New	58
FS290655N	PP-7 Dash Valve BUTTON, Red	55
FS291452N	"Easy-On" ADAPTER	10, 20
FS294314N	"Standard" Mounting BRACKET	75
FS296010N	"Universal" Mounting BRACKET	75
FS298817N	RED KNOB, for MV-3	52
FS298818N	YELLOW KNOB, for MV-3	52
FS-3055	Hose SUPPORT Spring 25-1/2" X 1-1/8"	184
FS-3056	Hose SUPPORT Spring 25-1/2" X 1-1/8"	184

Propriété exclusive de FleetSpec. Toute reproduction interdite. / Exclusive property of FleetSpec. Reproduction prohibited.

List numérique / Index

Numero de pièce Part Number	Description	Page
FS-3057	Hose SUPPORT Spring 12-1/2" X 1"	184
FS-3058	Hose SUPPORT Spring 15" X 1-1/16"	184
FS-3063	Rubber STRAP, 4"	201
FS-3065	Rubber STRAP, 41"	201
FS-3066	Rubber STRAP, 9"	201
FS-3067	Rubber STRAP, 15"	201
FS-3068	Rubber STRAP, 21"	201
FS-3069	Rubber STRAP, 31"	201
FS-3070	Rubber STRAP, Adjustable (24" max)	201
FS-312	Gladhand SEAL, Rubber, Surface Sealing	179
FS-312A	Gladhand SEAL, Rubber, Sealed Type	179
FS-312B	Gladhand SEAL, Polyurethane, Blue	179
FS-312BRS	Gladhand SEAL Set, 2 Red, 2 Blue, 4 Screens	179
FS-312BS	Gladhand SEAL, Poly Blue with Filter SCREEN	179
FS-312K	Gladhand SEAL, Polyurethane, Black	179
FS-312R	Gladhand SEAL, Polyurethane, Red	179
FS-312RS	Gladhand SEAL, Poly Red with Filter SCREEN	179
FS-313E	Emergency GLADHAND	180
FS-313S	Service GLADHAND	180
FS-315	Gladhand Grip EXTENSIONS (pair)	182
FS-316	Gladhand LOCK	184
FS-317E	Terminal BOLT	159
FS-318E	Shut-Off GLADHAND, Emergency	180
FS-318S	Shut-Off GLADHAND, Service	180
FS-319E	38° Angle Mount GLADHAND, Emergency	180
FS-319S	38° Angle Mount GLADHAND, Service	180
FS-320E	Surface Mount Shut-off GLADHAND, Emergency	181
FS-320S	Surface Mount Shut-off GLADHAND, Service	181
FS-321	"Dummy" Coupling with 16" Cable, Looped	181
FS-3220	Document HOLDER	201
FS-3220C	Replacement Rubber CAP for FS-3220	201
FS-3221	Document HOLDER	201
FS-3221C	Replacement COVER for FS-3221	201
FS-322E	45° Bracket Mount Swivel GLADHAND Emergency	181
FS-322S	45° Bracket Mount Swivel GLADHAND Service	181
FS-323E	45° Swingaway Shut-Off Gladhand Emergency	181
FS-323S	45° Swingaway Shut-Off Gladhand Service	181
FS-324	Gladhand Grip Handles, set of Red & Blue	182
FS-34009	"Sterco" style HUB CAP with Gasket	197
FS-34009-1	Hub Cap GASKET for FS-34009 (330-3009)	197
FS-34009WMP	FS-34009 HUB CAP with magnetic plug	196, 197
FS-34024	HUB CAP (repl 343-4024)	197
FS-34024-1	Hub Cap GASKET (for FS-34024)	197
FS-34195	HUB CAP (repl 343-4195)	197
FS-34195-1	Hub Cap GASKET (for FS-34195)	197
FS-34249	HUB CAP (repl 343-4249)	197
FS-34249-1	Hub Cap GASKET (for FS-34249)	197
FS-3583-8	Electrical JUNCTION BOX (7 Connectors)	190
FS-3584	Electrical JUNCTION BOX (14 Connectors)	190
FS-3585-8	Electrical JUNCTION BOX - Clear (7 Connectors)	190
FS-432	Clevis BUSHING 1/2-ID x 5/8-OD	23
FS-433	Clevis BUSHING 1/2-ID x 3/4-OD	23

Propriété exclusive de FleetSpec. Toute reproduction interdite. / Exclusive property of FleetSpec. Reproduction prohibited.

List numérique / Index

Numero de pièce Part Number	Description	Page
FS-434	Clevis BUSHING, 5/8-ID x 13/16-OD	23
FS-4523	3-way Elec. SOLENOID (Normally OPEN)	151
FS-473	Hose SEPARATOR, 3/8"	185
FS-473A	Hose SEPARATOR, 1/2"	185
FS-473AD	Hose SEPARATOR, 1/2", Double	185
FS-473D	Hose SEPARATOR, 3/8", Double	185
FS5000284X	Bendix TP-5 TRACTOR PROTECTION Valve	73
FS5000709XNB	Bendix AD-IP DRYER, Drop in (NO BRACKET)	28
FS-5001	Type 09 Air Brake Service CHAMBER	9
FS5001247N	AD-IP Mounting BRACKET Kit	29
FS5001455X	Use FS065706X	
FS-5001D	DIAPHRAGM <only>, Type 9	14
FS-5002	Type 12 Air Brake Service CHAMBER	9
FS5002595N	AD-9 Thermostat KIT (24V, 100W)	37
FS-5002D	DIAPHRAGM <only>, Type 12	14
FS-5003	Type 16 Air Brake Service CHAMBER	9
FS5003365X	Use FS065104N	
FS5003547N	AD-IP Purge Valve Maintenance KIT	29
FS-5003D	DIAPHRAGM <only>, Type 16	14
FS-5003L	Type 16LS Air Brake Service CHAMBER	9
FS-5004	Type 20 Air Brake Service CHAMBER	9
FS5004049N	AD-IS Governor / Delivery CHECK Valve, New	30
FS5004050X	Bendix AD-IS Dryer (DRM)	30
FS5004338N	AD-9 PURGE Valve Assy, 24 Volt, New	36
FS5004341X	Bendix AD-9 PURGE Valve Assy, 12V	36
FS5004342X	Bendix AD-9 PURGE Valve Assy, 24V	36
FS5004381N	AD-9 PURGE Valve Assy, 24V, 100W, Hard Seat	36
FS5004479N	AD-9 PURGE Valve Assy, 12V, 75W, Hard Seat	36
FS5004480N	AD-9 PURGE Valve Assy, 24V, 75W, Hard Seat	36
FS-5004D	DIAPHRAGM <only>, Type 20	14
FS-5004DL	DIAPHRAGM <only>, Type 20 Long Stroke	14
FS-5004L	Type 20 Air Brake Service CHAMBER, L/Stroke	9
FS-5005	Type 24 Air Brake Service CHAMBER	9
FS5005037N	Repair KIT for AD-9 Purge Valve	37
FS5005893N	Repair KIT for AD-9 Purge Valve	37
FS-5005D	DIAPHRAGM <only>, Type 24	14
FS-5005DL	DIAPHRAGM <only>, Type 24 Long Stroke	14
FS-5005L	Type 24 Air Brake Service CHAMBER, L/Stroke	9
FS-5006	Type 30 Air Brake Service CHAMBER	9
FS-5006D	DIAPHRAGM <only>, Type 30	14
FS-5006DL	DIAPHRAGM <only>, Type 30 Long Stroke	14
FS-5006L	Type 30 Air Brake Service CHAMBER, L/Stroke	9
FS-5007	Type 36 Air Brake Service CHAMBER	9
FS-5007D	DIAPHRAGM <only>, Type 36	14
FS5008414N	Use R950011N	
FS5010133X	Bendix AD-IS Air DRYER, 12V	30
FS5010211X	Bendix AD-IS Air DRYER, 24V	30
FS5010696X	Bendix AD-IS Air DRYER, 12V	30
FS5011075X	Bendix AD-IS Air Dryer (DRM)	30
FS5019291X	DC-4 Double CHECK Valve, Reman	45
FS-5012	Service Return SPRING	13
FS-5019	Spring Brake PUSH ROD 13.5 in.	12

Propriété exclusive de FleetSpec. Toute reproduction interdite. / Exclusive property of FleetSpec. Reproduction prohibited.

List numérique / Index

Numero de pièce Part Number	Description	Page
FS-5019-18	Spring Brake PUSH ROD 18.5 in. For Intraxx	12
FS-5019-22	Spring Brake PUSH ROD 22 in.	12
FS5019291X	Bendix DC-4 DOUBLE CHECK Valve	45
FS-5040	Replacement HOUSING, Standard Stroke	13
FS-5040L	Replacement HOUSING, Long Stroke	13
FS-5042	Spring Brake Clamp NUT & BOLT Ass'y	13
FS-5076	Yoke PIN <only>, 1/2"	12
FS-5077A	Yoke PIN <only>, 5/8"	12
FS-5081	YOKE Assembly 1/2" X 1/2"	12
FS-5082A	YOKE Assembly 5/8" X 1/2"	12
FS-5083A	YOKE Assembly 5/8" X 5/8"	12
FS-5143	Air Hose CLAMP	185
FS-5147	Air Hose CLAMP (2-hole)	185
FS-5150	Air Hose CLAMP (3-hole)	185
FS-5172-6	DRAIN Valve (5' cable, crimped)	102
FS-5173	DRAIN Valve (5' cable, uncrimped)	102
FS-5173-1	Cable FERRULE	102
FS-5173-4	DRAIN Valve (4' cable, crimped)	102
FS-5173-6	DRAIN Valve (5' cable, crimped)	102
FS-5174	3-Way DIVERTER Valve (1/4")	149
FS-5175	3-Way DIVERTER Valve (1/4")	149
FS-5175K	KNOB for FS-5175	149
FS-5176	RAPID DUMP Valve	149
FS-5177	3-Way, Auto Reset CONTROL Valve (VS-25223)	147
FS-5178	3-way Dump Truck REAR DOOR Valve	172
FS-5178DB	2-spool - 4 way Dump Truck REAR DOORS valve	172
FS-5179T	Toggle AIR VALVE	174
FS-5179TD	Toggle Detented AIR VALVE	174
FS-5180	5th Wheel Air Toggle Switch	174
FS-5181	Solenoid Control Valve	146, 173
FS-5181-C	Coil <only> for FS-5181	146, 173
FS-5182	3-Way, Auto Reset CONTROL Valve (VS25224)	147
FS-5210	Alcohol EVAPORATOR	41
FS-5210K	REBUILD KIT for Alcohol Evaporator	41
FS-5210SV	SAFETY Valve for Alcohol Evaporator	41
FS-5584	Pushrod DUST BOOT	12
FS-5606	30/30 Sealed SPRING BRAKE Ass'y 13" rod	7
FS-5606-18	30/30 Sealed SPRING BRAKE Ass'y 18" rod	7
FS-5606-18INT	30/30 Sealed SPRING BRAKE Ass'y 18" rod	7
FS-5606C	Standard CLAMP Ass'y for Piggyback	13
FS-5606CE	Economy CLAMP Ass'y for Piggyback	13
FS-5606CW	Wide CLAMP Ass'y for Piggyback	13
FS-5606INT	30/30 Sealed SPRING BRAKE Ass'y 13" Intraxx	7
FS-5606L	30/30 Sealed SPRING BRAKE Ass'y L/stroke	7
FS-5606L-18	30/30 Sealed SPRING BRAKE Ass'y L/stroke	7
FS-5606L-18INT	30/30 Sealed SPRING BRAKE Ass'y L/stroke	7
FS-5606L-INT	30/30 Sealed SPRING BRAKE Ass'y L/stroke	7
FS-5606L-WY	30/30 Sealed SPRING BRAKE Ass'y L/stroke	7
FS-5606R	Replacement Release Stud PLUG	13
FS-5608P	PIGGYBACK PLUS Kit (standard stroke)	8
FS-5608PL	PIGGYBACK PLUS Kit (long stroke)	8
FS-5620LS	Replacement RELEASE STUD (long stroke)	13

Propriété exclusive de FleetSpec. Toute reproduction interdite. / Exclusive property of FleetSpec. Reproduction prohibited.

List numérique / Index

Numero de pièce Part Number	Description	Page
FS-5624	SPRING BRAKE 24/30	7
FS-5915	Red Rubber PLUG, for "Stemco" Hub Caps	196
FS-5984	3/8" Magnetic Drain PLUG	196
FS-5990	Red Rubber PLUG, for "Stemco" Hub Caps	196
FS-6576	3-Way Electrical SOLENOID Valve, With Over-Ride	151
FS-6580	Manual CONTROL Valve (Repl. Neway 90054088)	149
FS-6580K	KNOB for FS-6580	149
FS-6581	3-Way Electrical SOLENOID Valve, N/C	151
FS-6582	PILOT Valve (Normally Open)	150
FS-6582NC	PILOT Valve (Normally Closed)	150
FS-6582U	PILOT Valve	150
FS-6583S	Silicone Filled, Stainless Steel GAUGE	153
FS-6584	GAUGE, 1-5/8 dia bottom mount	153
FS-6585	HEIGHT CONTROL Valve (Hendrickson VS-227)	129
FS-6586	HEIGHT CONTROL Valve (Neway 90054007)	128
FS-6586NT	HEIGHT CONTROL Valve (Neway 90554241)	127
FS-6586NTA	HEIGHT CONTROL Valve with LINK Kit	127
FS-6587	HEIGHT CONTROL Valve (Neway 90554271)	127
FS-6588NO	DUMP Valve for FS-6589	128
FS-6589NO	HEIGHT CONTROL Valve (Neway 90554334)	128
FS-6590	DUMP Valve for FS-6587	127
FS-6591	HEIGHT CONTROL Valve (Hendrickson 57977-000)	130
FS-6592	Height Control Valve (Barksdale KD-2205)	130
FS-6593	TAILGATE CONTROL Valve (BAV010)	173
FS-6594	LINKAGE Assembly (SRK 168)	133
FS-6594R	Rubber LOLLIPOP for FS-6594	133
FS-6595	LINKAGE Assembly - 21" (A14187)	133
FS-6596	PRESSURE PROTECTION Valve, with Filter	96, 148
FS-6596N	PRESSURE PROTECTION Valve (N90554107)	148
FS-6597	PRESSURE PROTECTION Valve (Haldex KN31171)	148
FS-6598	LINKAGE kit for FSKN27000N	133
FS-6599	PRESSURE PROTECTION Valve	148
FS-6600	Height Control Valve (Peerless 82341-Q115)	131
FS-6602	Height Control Valve (Hendrickson VS-228)	131
FS-6603	Height Control Valve (Freightliner KD-2204)	129
FS-6605	In-Line Quick Release Valve	183
FS-6606	In-Line Quick Release Valve	183
FS-6610	Height Control Valve (KD2360)	131
FS-6611	Height Control Valve (KD2358)	132
FS-6612	Height Control Valve (KD2374)	132
FS-6613	Height Control Valve (52321-Q303)	129
FS-6614	Height Control Valve (KD2228)	130
FS-6678	LINKAGE Assembly (SRK 205)	133
FS-6678R	Rubber LOLLIPOP for FS-6678	133
FS-6678RE	Rubber ELBOW for FS-6678	133
FS-6831	Pressure REGULATOR (1/8 NPT ports)	153
FS-6843	HEIGHT CONTROL Valve (Haldex 9055105)	127
FS-6848S	Silicone Filled, Stainless Steel GAUGE	153
FS-6849	GAUGE, 1-5/8 dia center mount	153
FS-6967-1	Universal Air Suspension BOX (12" Square)	154
FS-6967-1A	"Loaded" CONTROL BOX (12" Square)	156
FS-6967-1AM	"Loaded" CONTROL BOX (12" Square)	156

Propriété exclusive de FleetSpec. Toute reproduction interdite. / Exclusive property of FleetSpec. Reproduction prohibited.

List numérique / Index

Numero de pièce Part Number	Description	Page
FS-6967-1ASS	"Loaded" CONTROL BOX (12" Square)	156
FS-6967-1B	"Loaded" CONTROL BOX (12" Square)	155
FS-6967-1BSS	"Loaded" CONTROL BOX (12" Square)	155
FS-6967-1C	"Loaded" CONTROL BOX (12" Square)	155
FS-6967-1CSS	"Loaded" CONTROL BOX (12" Square)	155
FS-6967-1D	DOOR Replacement Kit for FS-6967-1	159
FS-6967-1E	Lift Axle CONTROL BOX	155
FS-6967-1FSS	Lift Axle CONTROL BOX	157
FS-6967-1G	Lift Axle CONTROL BOX	158
FS-6967-1H	Replacement HINGE & PIN for FS-6967-1 Box	159
FS-6967-1J	Lift Axle CONTROL BOX	157
FS-6967-1K	Lift Axle CONTROL BOX	156
FS-6967-1L	Lift Axle CONTROL BOX	155
FS-6967-1M	Lift Axle CONTROL BOX	158
FS-6967-1NH	Same as FS-6967-1, with No Holes	154
FS-6967-1SS	Universal Air Suspension BOX (12", S/Steel)	154
FS-6967-1SSNH	Universal Air Suspension BOX, with No Holes	154
FS-6967-2	Universal Air Suspension BOX (8-1/4" Square)	161
FS-6967-2A	"Loaded" CONTROL BOX (8-1/4" Square)	162
FS-6967-2ASS	"Loaded" CONTROL BOX (8-1/4" Square) SS	162
FS-6967-2B	"Loaded" CONTROL BOX (8-1/4" Square)	162
FS-6967-2BSS	"Loaded" CONTROL BOX (8-1/4" Square) SS	162
FS-6967-2C	"Loaded" CONTROL BOX (8-1/4" Square)	162
FS-6967-2D	DOOR Replacement Kit for FS-6967-2	159
FS-6967-2E	"Loaded" CONTROL BOX (8-1/4" Square)	162
FS-6967-2ESS	"Loaded" CONTROL BOX (8-1/4" Square), SS	162
FS-6967-2F	Same as FS-6967-2, with 3 pre-punched holes	161
FS-6967-2SS	CONTROL BOX, Stainless Steel / 8-1/4" Square	161
FS-6967-3	Universal Air Suspension BOX (18"x10"x6")	163
FS-6967-3D	Door Kit for FS-6967-3	163
FS-6967-4	Manac Air Suspension BOX (12"x10"x6")	164
FS-6967-4D	DOOR Assembly for FS-6967-4	164
FS-6967-5	Manac Air Suspension BOX (18"x10"x6")	164
FS-6967-5A	"Loaded" CONTROL BOX (18"x10"x6")	165
FS-6967-5B	"Loaded" CONTROL BOX (18"x10"x6")	165
FS-6967-5D	Door for FS-6967-5	164
FS-6967-6	Clear Cover Composite Suspension Box 6 X 6 In	160
FS-6967-6A	CONTROL BOX WITH Air Reset	160
FS-6967-6B	CONTROL BOX, full Manual Control	160
FS-6967-7	Clear Cover Composite Suspension Box 8 X 10-1/2	160
FS-6967-8	CONTROL BOX, empty (Manac 223-352)	166
FS-6967-8A	CONTROL BOX, with Regulator & Gauge	166
FS-6967-L	LATCH Replacement Kit, fits all Boxes	159
FS-6967-P	Hinge PIN <only> for FS-6967-1	159
FS-6970	7/8" GROMMET, for Suspension Boxes	159
FS-6971	7/8" Hole PLUG, for Suspension Boxes	159
FS-70-2120	BREATHER Fitting 1/8" NPT	143, 159
FS-70-2140	BREATHER Fitting 1/4" NPT	143, 159
FS-70-2160	BREATHER Fitting 3/8" NPT	143, 159
FS7101X	CR Brakemaster AFTERCOOLER Model 62	40
FS7103X	CR Brakemaster AFTERCOOLER Model 68	40
FS800004X	Bendix PP-DC CONTROL Valve	56

Propriété exclusive de FleetSpec. Toute reproduction interdite. / Exclusive property of FleetSpec. Reproduction prohibited.

List numérique / Index

Numero de pièce Part Number	Description	Page
FS800034N	PP-DC CONTROL Valve, New	56
FS800034X	Bendix PP-DC CONTROL Valve	56
FS800142X	Bendix PP-DC CONTROL Valve	56
FS800155N	ST-4 SAFETY Valve, New	70
FS800257N	MV-3 Control MODULE, New	53
FS800257X	Bendix MV-3 Control MODULE	53
FS800258X	Bendix MV-3 Control MODULE	53
FS800259N	MV-3 Control MODULE, New	53
FS800259X	Bendix MV-3 Control MODULE	53
FS800260N	MV-3 Control MODULE, New	53
FS800260X	Bendix MV-3 Control MODULE	53
FS800333N	QR-L In-line QUICK RELEASE Valve, New	58
FS800350N	ST-4 SAFETY Valve, New	29, 30, 37, 70
FS800353X	Bendix MV-3 Control MODULE	53
FS800365N	R-12 RELAY Valve, New	60
FS800372N	SC-3 Single Check Valve, New	66
FS800375N	SC-3 Single Check Valve, New	66
FS800396X	Bendix TP-5 TRACTOR PROTECTION Valve	73
FS800404N	AD-IP, AD-IS PURGE Valve Assy, New	28, 30
FS800404X	Bendix AD-IP, AD-IS PURGE Valve Assy.	28, 30
FS800405N	AD-9 PURGE Valve Assy, 12 Volt, New	36
FS800470N	R-12DC Relay Valve - New	61
FS800470X	Bendix R-12DC Relay Valve - Reman	61
FS800471N	R-12DC Relay Valve - New	61
FS800471X	Bendix R-12DC Relay Valve - Reman	61
FS800477N	R-12DC Relay Valve - New	61
FS800477X	Bendix R-12DC Relay Valve - Reman	61
FS800481N	R-12DC Relay Valve - New	61
FS800481X	Bendix R-12DC Relay Valve - Reman	61
FS800515N	MV-3 Control MODULE, New	53
FS800515X	Bendix MV-3 Control MODULE	53
FS800516N	MV-3 Control MODULE, New	53
FS800516X	Bendix MV-3 Control MODULE	53
FS800517N	MV-3 Control MODULE, New	53
FS800517X	Bendix MV-3 Control MODULE	53
FS800518X	Bendix MV-3 Control MODULE	53
FS800519N	MV-3 Control MODULE, New	53
FS800519X	Bendix MV-3 Control MODULE	53
FS800521N	MV-3 Control MODULE, New	53
FS800521X	Bendix MV-3 Control MODULE	53
FS800522X	Bendix MV-3 Control MODULE	53
FS800523N	MV-3 Control MODULE, New	53
FS800523X	Bendix MV-3 Control MODULE	53
FS800529X	Bendix MV-3 Control MODULE	53
FS800573N	MV-3 Control MODULE, New	53
FS800573X	Bendix MV-3 Control MODULE	53
FS800622N	MV-3 Control MODULE, New	53
FS800622X	Bendix MV-3 Control MODULE	53
FS800629N	E-8P Dual Circuit FOOT Valve, New	48
FS800629X	Bendix E-8P Dual FOOT Valve	48
FS800630N	E-8P Dual Circuit FOOT Valve, New	48
FS800630X	Bendix E-8P Dual FOOT Valve	48

Propriété exclusive de FleetSpec. Toute reproduction interdite. / Exclusive property of FleetSpec. Reproduction prohibited.

List numérique / Index

Numero de pièce Part Number	Description	Page
FS800632X	Bendix E-10P FOOT Valve	49
FS800636N	R-12 RELAY Valve	60
FS800887X	Use FS109991X	
FS800960X	Bendix TC-7 Trailer CONTROL Valve	71
FS800972X	Use FS109992X	
FS801266N	Use FS5010696XO	
FS801315X	Bendix PP-DC DASH Valve	56
FS801479X	Bendix M-32QR ABS MODULATOR 12V	109
FS801481X	Bendix M-32QR ABS MODULATOR 12V	109
FS801631X	Bendix MV-3 Control MODULE	53
FS801665X	Bendix M-32 ABS MODULATOR	109
FS802743N	Bendix QR-N Style Quick Release Valve	58
FS802745N	Bendix QR-N Style Quick Release Valve	58
FS803121X	Bendix ATR-6 TRACTION RELAY Valve	108
FSA3546N	Fuller style Transmission RANGE Valve, New	172
FSA3546X	Fuller Transmission RANGE Valve	172
FSA4688X	Fuller Transmission SLAVE Valve	172
FSA6909N	Transmission Air SHIFT Valve, New	171
FSA6913N	Transmission Air SHIFT Valve, New	171
FSA6915N	Transmission Air SHIFT Valve, New	171
FSA6918N	Transmission Air SHIFT Valve, New	171
FSBE13240N	Tractor Spring Brake Circuit Light SWITCH, New	189
FSBE13250N	Service Circuit Stoplight SWITCH, New	189
FSBE13255N	Trailer Emergency Stoplight SWITCH, New	189
FS-GUAS1132	Gunite Style ASA	21
FS-GUAS1133	Gunite Style ASA	21
FS-GUAS1136	Gunite Style ASA	21
FS-GUAS1140	Gunite Style ASA	21
FS-GUAS1141	Gunite Style ASA	21
FS-GUAS1147	Gunite Style ASA	21
FS-GUAS3000	Gunite style ASA YOKE kit	11
FS-GUAS3000GP	Gunite style ASA YOKE kit, Greasable Pins	11
FS-GUAS3000LP	Large PIN for FS-GUAS3000	11
FS-GUAS3000SP	Small PIN for FS-GUAS3000	11
FS-GUAS3016	Gunite style CLEVIS	11, 21
FS-GUAS3016GP	Gunite style ASA YOKE kit, Greasable Pins	11, 21
FS-GUAS3018	Gunite style CLEVIS	11, 21
FS-GUAS3018GP	Gunite style ASA YOKE kit, Greasable Pins	11, 21
FS-GUAS3019	Gunite style CLEVIS	11, 21
FS-GUAS3019GP	Gunite style ASA YOKE kit, Greasable Pins	11, 21
FS-GUAS4004	Pin Kit, 6 Large, 6 Small, 12 Cotter Pins	11, 21
FS-H00450CE	Hadley style HCV (H00450CE)	132
FS-HUM501A	Humphrey style Air Piloted Valve	150
FS-HUM501-4A	Humphrey style Air Piloted Valve	150
FSK021557X	Bendix SR-7 SPRING BRAKE Valve	69
FSK021558X	Bendix SR-7 SPRING BRAKE Valve	69
FSK021559X	Bendix SR-7 SPRING BRAKE Valve	69
FSK021560X	Bendix SR-7 SPRING BRAKE Valve	69
FSK021562X	Bendix SR-7 SPRING BRAKE Valve	69
FSK021563X	Bendix SR-7 SPRING BRAKE Valve	69
FSK022105N	AD-IS / AD-IP Purge Valve	28, 30
FSK041395N	AD-9 Check Valve (New Style Cover)	37

Propriété exclusive de FleetSpec. Toute reproduction interdite. / Exclusive property of FleetSpec. Reproduction prohibited.

List numérique / Index

Numero de pièce Part Number	Description	Page
FSK052778	Use SE110500N	
FSKN20080X	Haldex DOUBLE FLIPPER Valve	85
FSKN20090X	Haldex DOUBLE FLIPPER Valve	85
FSKN20110X	Haldex DOUBLE FLIPPER Valve	85
FSKN20541X	Haldex Trailer Brake CONTROL Valve	83
FSKN20606X	Haldex Manifold Dash MODULE	79
FSKN20607X	Haldex Manifold Dash MODULE	79
FSKN20612X	Haldex Manifold Dash MODULE	79
FSKN20615X	Haldex Manifold Dash MODULE	79
FSKN22100X	Haldex Single Circuit FOOT Valve	78
FSKN22140X	Haldex Dual Circuit FOOT Valve	78
FSKN26000N	RT-4 Multifunction TRAILER Valve, New	83
FSKN26000X	Haldex RT-4 Multifunction TRAILER Valve	83
FSKN26010X	Haldex RT-4 Multifunction TRAILER Valve	83
FSKN26020N	RT-4 Multifunction TRAILER Valve, New	83
FSKN26020X	Haldex RT-4 Multifunction TRAILER Valve	83
FSKN27000N	HEIGHT CONTROL Valve	128
FSKN28030X	Haldex INVERSION Valve	79
FSKN28060N	RELAY Valve, New	80
FSKN28060X	Haldex RELAY Valve	80
FSKN28061X	Haldex RELAY Valve	80
FSKN28065X	Haldex RELAY Valve	80
FSKN28071N	RELAY Valve, New	80
FSKN28071X	Haldex RELAY Valve	80
FSKN28080N	RELAY Valve, New	81
FSKN28080X	Haldex RELAY Valve	81
FSKN28130X	Haldex RELAY Valve	81
FSKN28131X	Haldex RELAY Valve	81
FSKN28140X	Haldex RELAY Valve	81
FSKN28300X	Haldex RELAY Valve	80
FSKN28500N	RG-2 RELAY Valve, New	82
FSKN28510N	RG-2 RELAY Valve, New	82
FSKN28520N	RG-2 RELAY Valve, New	82
FSKN28531X	Haldex RG-2 RELAY Valve	82
FSKN28551X	Haldex RG-5 RELAY Valve	82
FSKN28600N	FF-2 FULL FUNCTION Valve, New	79
FSKN28600X	Haldex FF-2 FULL FUNCTION Valve	79
FSKN28601N	FF-2 FULL FUNCTION Valve, New	79
FSKN28601X	Haldex FF-2 FULL FUNCTION Valve	79
FSKN30200X	Haldex EMERGENCY RELAY Valve	82
FSKN30300N	EMERGENCY RELAY Valve, New	82
FSKN30300X	Haldex EMERGENCY RELAY Valve	82
FSKN30400N	EMERGENCY RELAY Valve, New	82
FSKN30400X	Haldex EMERGENCY RELAY Valve	82
FSKN32040X	Haldex QUICK RELEASE Valve	80
FSKN32041X	Haldex QUICK RELEASE Valve	80
FSKN33000X	Haldex "Pure Air" DRYER, 12V	40
FSKN33050X	Haldex "Tornado" AfterCooler, 12V, Reman	40
FSKN34050X	Haldex TRACTOR PROTECTION Valve	84
FSKN34060X	Haldex TRACTOR PROTECTION Valve	84
FSKN34070X	Haldex TRACTOR PROTECTION Valve	84
FSKN34080X	Haldex TRACTOR PROTECTION Valve	85

Propriété exclusive de FleetSpec. Toute reproduction interdite. / Exclusive property of FleetSpec. Reproduction prohibited.

List numérique / Index

Numero de pièce Part Number	Description	Page
FSKN34090X	Haldex TRACTOR PROTECTION Valve	85
FSKN34100X	Haldex TRACTOR PROTECTION Valve	85
FSKN34110X	Haldex TRACTOR PROTECTION Valve	85
FSKN68230N	SOLENOID Valve 12 V, with Bracket, New	189
FS-MC8056KTA	Pin Kit for Stemco ASA	10, 25
FS-MC8420KTA	Crewson "Auto-Check" style ASA YOKE kit	10, 25
FS-MC8420LP	Large PIN for FS-NC8420KTA	10, 25
FS-MC8420SP	Small PIN for FS-NC8420KTA	10, 25
FS-MC8480KTA	Crewson "Auto-Check" style ASA YOKE kit	10, 25
FS-MK21106S	Stemco Crewson ASA	24
FS-MK22100S	Stemco Crewson ASA	24
FS-MK22106S	Stemco Crewson ASA	24
FS-MK22153S	Stemco Crewson ASA	24
FS-MK41106SE	Stemco Crewson ASA w/ Stroke Ind, Std SB	24
FS-MK42100SE	Stemco Crewson ASA w/ Stroke Ind, Std SB	24
FS-MK42106SE	Stemco Crewson ASA w/ Stroke Ind, Std SB	24
FS-MK71106SE	Stemco Crewson ASA w/ Stroke Ind, Std SB	24
FS-MK72100SE	Stemco Crewson ASA w/ Stroke Ind, Std SB	24
FS-MK72106SE	Stemco Crewson ASA w/ Stroke Ind, Std SB	24
FS-R801041	SLACK ADJUSTER, Meritor style	18
FS-R801042	SLACK ADJUSTER, Meritor style	18
FS-R801073	SLACK ADJUSTER, Meritor style	18
FS-R801074	SLACK ADJUSTER, Meritor style	18
FS-R802446	SLACK ADJUSTER, Meritor style	19
FS-R802447	SLACK ADJUSTER, Meritor style	19
FS-R802486	SLACK ADJUSTER, Meritor style	19
FS-R802487	SLACK ADJUSTER, Meritor style	19
FS-R810005	Meritor style PIN kit	10, 18
FS-R810019	Meritor style ASA YOKE kit	10, 18
FS-R810019GP	Meritor style ASA YOKE kit, Greasable Pins	10, 18
FS-R810019LP	Long PIN for Meritor ASA Yoke	10, 18
FS-R810019SP	Small PIN for Meritor ASA Yoke	10, 18
FS-R810021	Meritor style ASA YOKE kit (LS)	10, 18
FS-R810021GP	Meritor style ASA YOKE kit, Greasable Pins	10, 18
FS-T221	Turbo-2000, HD-200 Purge Tank Kit	42
FS-T224	Desiccant CARTRIDGE, CR, New	42
FS-T224A	Desiccant CARTRIDGE, CR, New	42
FST51301N	Tramec style Trailer Emergency Valve	95
FS-T619110	Heater & Thermo Kit 12V	42
FS-T619111	Heater & Thermo Kit 24V	42
FS-T620602X	CR Turbo-2000 Air DRYER, 12 Volt	42
FS-T620606X	CR Turbo-2000 Air DRYER, 24 Volt	42
FSWM100361X	Williams EMERGENCY RELAY Valve	100
FSWM100362X	Williams EMERGENCY RELAY Valve	100
FSWM111263X	Williams Adjustable PRESSURE PROTECTION	96
FSWM111276X	Williams 3-Way REGULATING Valve	96
FSWM111913X	Williams Auxiliary Tank CONTROL Valve	97
FSWM111999X	Williams High Volume, compensating RELAY Valve	99
FSWM112173X	Williams QUICK RELEASE Valve	100
FSWM112201X	William RATIO RELAY Valve (Repl WM318A)	99
FSWM112211X	Williams TRACTOR PROTECTION Valve	99
FSWM112215X	Williams EMERGENCY SAFETY Valve	97

Propriété exclusive de FleetSpec. Toute reproduction interdite. / Exclusive property of FleetSpec. Reproduction prohibited.

List numérique / Index

Numero de pièce Part Number	Description	Page
FSWM112229X	Willaims PARKING BRAKE Control Valve	97
FSWW112371X	Williams Non-compensating, Adjustable RELAY Viv.	101
FSWM112468X	Willaims High Flow MODULATING Valve	96
FSWM113726X	Williams Hand Operated REGULATING Valve	98
FSWM113730X	WilliamsHand Control Valve (WM606)	98
FSWM118316X	Williams 2 Pos. 4-Way CONTROL Valve	98
FSWM147C	N/C RELAY Valve (Williams style), New	101, 151
FSWM147F	N/O RELAY Valve (Williams style), New	101, 151
FSWM147LX	Williams RELAY Valve	101, 151
FSWM147P	N/O RELAY Valve (Williams style), New	101, 151
GCP1012	Greasable Clevis Pin 1/2"	12
GCP1014	Greasable Clevis Pin 1/4"	12
GCP1058	Greasable Clevis Pin 5/8"	12
KH5468X	Kelsey Hayes RELAY Valve	87
KH5470X	Kelsey Hayes RELAY Valve	87
KPL1000	King Pin LOCK	202
MSA824000	MANUAL SLACK ADJUSTER, Meritor style	17
MSA824001	MANUAL SLACK ADJUSTER, Meritor style	17
MSA824003	MANUAL SLACK ADJUSTER, Meritor style	17
MSA824004	MANUAL SLACK ADJUSTER, Meritor style	17
MSA824007	MANUAL SLACK ADJUSTER, Meritor style	17
NG12391N	Manual / Electric CONTROL Valve (K910019)	140
NG12392-C	Solenoid COIL for NG12391N, 2N, 9N	143
NG12392MR	Manual Return, Manual CONTROL Valve	140
NG12392N	Manual / Electric CONTROL Valve	140
NG12392PR	Pilot Return, Manual CONTROL Valve	140
NG12392S	Electric ACTUATOR for NG12391N, 2N	143
NG12392SP	Spool only for Norgren 5 port valve	143
NG12392SR	Spring Return, Manual CONTROL Valve	141
NG12392W	Electrical WIRE & SOCKET for NG12391N, 2N, 9N	143
NG12393N	Manual CONTROL Valve	141
NG12394N	Air Operated CONTROL Valve	141
NG12395N	Manual CONTROL Valve	141
NG12396N	Air Operated CONTROL Valve	142
NG12397	KNOB <only> for NG12391, 92	143
NG12398C	Solenoid COIL for 12398N	143
NG12398N	Electric CONTROL Valve	142
NG12398S	Electric ACTUATOR for NG12398N	143
NG12399N	Electric CONTROL Valve	142
NG12399S	Electric ACTUATOR for NG12399N	143
NG12400	Palm KNOB <only> for NG12392, 93, 95	143
NG12401N	Air Control Valve	145
NG12410N	Air Operated CONTROL Valve	142
NG616-10	Panel-Mount NUT <only>	143
R950011N	AD-SP, AD -IS CARTRIDGE, New	30, 31, 38
R950013	TURBO CUT-OFF Valve Kit	39
R950014	Purge Valve KIT	38
R950015	HEATER Kit (12 Volt)	39
R950016	HEATER Kit (24 Volt)	39
R950017	Outlet Check Valve KIT	39
R950044	Regeneration Valve KIT	39
R950045	DIAPHRAGM <only> for Regeneration Valve	39

Propriété exclusive de FleetSpec. Toute reproduction interdite. / Exclusive property of FleetSpec. Reproduction prohibited.

List numérique / Index

Numero de pièce Part Number	Description	Page
R955205N	Wabco style DRYER, 12 Volt, New	38
R955205X	Wabco DRYER, 12 Volt	38
R955206N	Wabco style DRYER, 24 Volt, New	38
R955206X	Wabco DRYER, 24 Volt	38
R955300X	Wabco DRYER, 12 Volt, Volvo VN	38
RA12391N	2-Position, 5-port (3/8) CONTROL Valve	139
RA12392N	2-Position, 5-port (3/8) CONTROL Valve	139
RA12392S	Solenoid Coil <only>	139
RA12392SP	Spool Kit	139
RDB1000	Rubber DOCK BUMPER, 6x2.75x3	198
RDB1001	Rubber DOCK BUMPER, 8x2.5x2.25	198
RDB1002	Rubber DOCK BUMPER, 8.125x5.5x3.5	198
RDB1003	Rubber DOCK BUMPER, 4.75x3.125x5.625	198
RDB1004	Rubber DOCK BUMPER, 16x2.375x2	199
RDB1005	Rubber DOCK BUMPER, 6x4x3.25	199
RDB1006	Rubber DOCK BUMPER, 5.25x3.5x4.375	199
RDB1020	"D" Rubber DOCK BUMPER, 6x4x3.5	200
RDB1021	"D" Rubber DOCK BUMPER, 12x4x3.5	200
RDB1022	"D" Rubber DOCK BUMPER, 36x4x3.5	200
RWC1000	Rubber "Pyramid" WHEEL CHOCK	200
RWC1001	Rubber "Contour" WHEEL CHOCK	200
S4341003100	Pressure Control CHECK Valve	38
SE110139N	SERVICE RELAY Valve, New	89
SE110139X	Sealco SERVICE RELAY Valve	89
SE110148X	Sealco SPRING BRAKE Control Valve	93
SE110170N	SPRING BRAKE Control Valve, New	93
SE110170X	Sealco SPRING BRAKE Control Valve	93
SE110171N	SPRING BRAKE Control Valve, New	94
SE110171X	Sealco SPRING BRAKE Control Valve	94
SE110191N	SPRING BRAKE Control Valve, New	94
SE110191X	Sealco SPRING BRAKE Control Valve	94
SE110197N	SERVICE RELAY Valve, New	89
SE110197X	Sealco SERVICE RELAY Valve	89
SE110200N	Charging RELAY EMERGENCY Valve, New	92
SE110200X	Sealco Charging RELAY EMERGENCY Valve	92
SE110205X	Sealco Charging RELAY EMERGENCY Valve	92
SE110207X	Sealco SERVICE RELAY Valve	90
SE110310N	SPRING BRAKE Control Valve, New	93
SE110310X	Sealco SPRING BRAKE Control Valve	93
SE110315N	SPRING BRAKE Control Valve, New	93
SE110315X	Sealco SPRING BRAKE Control Valve	93
SE110338N	RELAY EMERGENCY Valve, New	93
SE110338X	Sealco RELAY EMERGENCY Valve	93
SE110360N	LOV-2 SERVICE RELAY Valve, New	89
SE110360X	Sealco LOV-2 SERVICE RELAY Valve	89
SE110380N	SERVICE RELAY Valve, New	89
SE110380X	Sealco LOV-4 SERVICE RELAY Valve	89
SE110400X	Sealco Dual Circuit FOOT Valve	95
SE110410N	LOV-2 SERVICE RELAY Valve, New	89
SE110410X	Sealco LOV-2 SERVICE RELAY Valve	89
SE110415N	SERVICE RELAY Valve, New	89
SE110415X	Sealco LOV-4 SERVICE RELAY Valve	89

Propriété exclusive de FleetSpec. Toute reproduction interdite. / Exclusive property of FleetSpec. Reproduction prohibited.

List numérique / Index

Numero de pièce Part Number	Description	Page
SE110450X	Sealco SERVICE RELAY Valve	89
SE110460X	Sealco Charging RELAY EMERGENCY Valve	92
SE110470X	Sealco Charging RELAY EMERGENCY Valve	92
SE110475X	Sealco Charging RELAY EMERGENCY Valve	92
SE110500N	SPRING BRAKE PRIORITY Valve, New	94
SE110500X	Sealco SPRING BRAKE PRIORITY Valve	94
SE110555X	Sealco AUTO RESET Control Valve	91
SE110570N	CONTROL LINE Valve, New	90
SE110570X	Sealco CONTROL LINE Valve	90
SE110580N	CONTROL LINE Valve, New	90
SE110580X	Sealco CONTROL LINE Valve	90
SE110600X	Sealco SERVICE RELAY Valve	89
SE110700N	SERVICE RESERVOIR PRIORITY Valve, New	94
SE110800N	SERVICE RESERVOIR PRIORITY Valve, New	94
SE140200N	PRESSURE PROTECTION Valve, New	88
SE140270N	PRESSURE PROTECTION Valve, New	88
SE140280N	PRESSURE PROTECTION Valve, New	88
SE17600BN	Push-Pull HAND CONTROL valve, New	91
SE2550N	Supply Line FILTER, New	88
SE3100N	MINI VALVE, New	91
SE3100X	Sealco MINI VALVE	91
SE3800N	In-Line QUICK RELEASE Valve, New	88
SE3800X	Sealco In-Line QUICK RELEASE Valve	88
SE6125-2X	Sealco Single Circuit FOOT Valve	95
SE9125X	Sealco SERVICE RELAY Valve	90
SE99600BN	Auto Shut-Off Push-Pull Valve	91
SEA1000-5AX	Sealco Valve Replacement CARTRIDGE	92
SEA1000SN	RELAY EMERGENCY Valve, New	92
SEA1000SX	Sealco RELAY EMERGENCY Valve	92
SH12387EC	End Cover KIT for SH12387	144
SH12387GK	Rebuild KIT for SH12387N	144
SH12387MG	Metal GASKET <only> for SH12387N	144
SH12387N	Schrader style AIR-ELECTRIC Valve, New	144
SH12387S	SOLENOID HEAD for SH12387N	144
SH12387SK	Solenoid Head Service KIT	144
SH12387X	Schrader AIR-ELECTRIC Valve	144
VE320121MR	4-Way, 2-Position Push-Pull CONTROL Valve	173
VE320122MR	4-Way, Holding Type Push-Pull CONTROL Valve	173
WA103600X	Wagner RF RELAY Valve	86
WA85490X	Wagner RG-4 Tandem RELAY Valve	86
WA88802X	Wagner RT RELAY Valve	86
WA88812X	Wagner RT RELAY Valve	86
WA98730X	Wagner RT-2 TRAILER Valve	86
WG5901	Wheel SPACER (Repl. Accuride 5901)	195
WG5902	Wheel SPACER (Repl. Accuride 5902)	195
WG5903	Wheel SPACER (Repl. Accuride 5903)	195
WG7381	Wheel SPACER (Repl. Accuride 7381)	195
WG7902	Wheel SPACER (Repl. Accuride 7902)	195

Propriété exclusive de FleetSpec. Toute reproduction interdite. / Exclusive property of FleetSpec. Reproduction prohibited.