



MINI-LIGHTBARS

BEACONS

BACK-UP ALARMS

CAMERA SYSTEMS

DIRECTIONAL WARNING

PERIMETER LIGHTING

LIGHTBARS



# THE DRIVING FORCE

Federal Signal is the **Driving Force** of industry solutions for municipal, utility, tow and recovery and DOT vehicles. Our Amber products offer customers solutions to improve work zone safety—everyday. From beacons to lightbars, controllers and back-up cameras—we work with you to provide solutions to fit your needs and meet the demands of your ever changing work environments.

***Federal Signal brings together revolutionary technologies to create a SAFER, SIMPLER and SMARTER warning system.***

**Solaris® LED Reflector Technology**



Federal Signal's Solaris® LED reflector design is engineered to significantly increase off-axis warning. The high-efficiency Solaris reflector maximizes the LED light source to eliminate dark spots and distribute 360-degrees of light coverage.



**ROC (Reliable Onboard Circuitry™) Technology**



Federal Signal introduced a breakthrough in lightbar construction with the revolutionary ROC (Reliable Onboard Circuitry™) technology. ROC is manufactured to eliminate approximately 85% of the connection failure points found in a typical lightbar assembly. Wires, connections and assemblies have been replaced by PCB assemblies — reducing labor repair time and increasing the road time for emergency vehicles.



**FS Convergence Network**



The FS Convergence Network provides “plug-n-play” installation from Federal Signal's SmartSiren® Platinum, amplifier and controller, to our family of serial communication lightbars and the Interior Lighting System (ILS).



**SpectraLux™ Multicolor LED Technology**



Exclusive to Federal Signal, SpectraLux™ multicolor LED technology provides the ability for a lighthead to change color while in operation. SpectraLux is available in Vision SLR and Valor lightbars and the IMPAXX6 exterior light.



**SLR (Solaris® LED Rotator) Design**



Federal Signal's Solaris SLR design significantly maximizes the LED light source for full light coverage. The SLR rotator in the SLR Beacon provides a superior LED rotating solution fit for any work truck to improve visibility and work zone safety.





<b>Mini-Lightbars</b>		<b>Interior Mount Warning Lights</b>	
HighLighter™ LED.....	4	Viper® S2.....	46
HighLighter™ LED Economy .....	5	FireBeam®.....	46
HighLighter™.....	5	Littlite®.....	47
HighLighter™ Strobe .....	6	LED Compartment Light.....	47
24" Legend® .....	7	<b>Area Lighting</b>	
21" Mini-JetSolaris® .....	8	9x7 Scene Light .....	48
12" Legend® Sets .....	9	Wireless VisiBeam®/VisiBeam®.....	48
9" MicroEscape .....	9	GHSCENE .....	49
TurboBeam® Mini-Lightbars .....	10	Tractor and Utility.....	49
<b>Mini-Lightbar Specification Page .....</b>	<b>11</b>	<b>Back-up Alarms and Mobile Camera Systems</b>	
<b>Beacons</b>		2012 Series Back-up Alarms.....	50
SLR Beacon .....	12	Evacuator Back-up Alarms.....	50
UltraStar® LED .....	13	Reactor Series Back-up Alarms.....	50
Pulsator® LED.....	14	Two-Tone Alarms .....	51
Model 651 LED .....	15	Grommet-mount Alarms .....	51
AL2.....	16	Switch .....	51
AS2.....	17	Mobile Camera Systems.....	52
US5, US6, US7 UltraStar®.....	18	<b>Accessories</b>	
Model 901/951 .....	20	Headlight/Taillight Flashers.....	53
Model 851 .....	21	Intelli-Flash Flashers.....	53
Model 651 .....	22	Mounting Bars .....	53
Pulsator® 551 Plus.....	24	Switch Controls .....	54
Pulsator® 451 Plus.....	25	Ignition Delay Timer .....	54
Model 401 .....	26	<b>Lamp Replacement Parts .....</b>	<b>55</b>
Firebolt®.....	27	<b>Lightbars</b>	
Renegade®.....	28	Legend® LPX Discrete .....	56
Sentry® .....	29	Legend® LPX.....	57
Model 100 .....	30	Legend® .....	58
<b>Beacon Specifications.....</b>	<b>31</b>	Valor™ .....	60
<b>Directional Warning Lights</b>		JetSolaris® LED .....	62
VPX SignalMaster™ .....	32	JetStream® LED .....	63
SignalMaster™ .....	33	JetStream® .....	64
LED SignalMaster™ .....	32	TurboBeam® .....	65
SignalMaster™ .....	34	<b>Hook Kit Reference Guide .....</b>	<b>66</b>
SignalMaster™ Controls .....	34	<b>Lightbar Common Replacement Parts.....</b>	<b>67</b>
SignalMaster™ Mounting Brackets .....	34	<b>Parts Index.....</b>	<b>68</b>
<b>External Mount/Perimeter Lights</b>		<b>Terms and Conditions .....</b>	<b>73</b>
Viper® EXT .....	35		
IPX6 IMPAXX® .....	36		
IPX3 IMPAXX®.....	37		
Viper/IMPAXX® Brackets.....	38		
MicroPulse™ 6 .....	39		
MicroPulse™ 3 .....	39		
3600 LED Lights .....	40		
7x3 QuadraFlare® .....	41		
6x4 QuadraFlare® .....	41		
9x7 QuadraFlare® .....	42		
In-line Corner LED Systems.....	42		
Silver Series® LED Systems.....	43		
SignalTech® LED lights .....	44		
Grille Lights .....	45		
Mount Boxes .....	45		

**General Notes**

1. All voltage is 12V (V denotes volts) unless marked otherwise. Contact the factory for pricing and availability of 24V models.
2. Standard rotators: 95 FPM. Medium rotators: 120 FPM. Fast rotators: 175 FPM (halogen models).
3. Prices for lightbars do not include controls (purchase separately) unless otherwise noted.
4. Prices for custom JetStream lightbars do not include inserts (purchase separately).
5. Product code: -95 and Z=Service Replacement Parts.
6. For detailed information on how to order, consult the product bulletins or contact the factory at 800-824-0254.

# HighLighter™ LED

- Low-profile, only 2.6" tall; 15" long
- Optimized Solaris® LED reflector maximizes warning lights at 360-degrees and 90-degrees off-axis
- Twenty-one Selectable flash patterns with synchronization capability
- Pattern selection using MagnetSelect® feature which enables easy selection from flash patterns using a magnet
- Split-color models available
- LEDs offered in Amber, Blue, Green, Red, and White
- Domes available in Amber, Blue, Clear, Green, and Red
- Five-year LED warranty



454201-02SC



Model	Description
-------	-------------

**Solid-color models**

*Suction-cup magnet mount models, include cigarette plug with on/off switch*

454200-02SC	Amber LEDs with Amber dome
454200-03SC	Blue LEDs with Blue dome
454200-04SC	Red LEDs with Red dome
454200-05SC	White LEDs with Clear dome
454200-06SC	Green LEDs with Green dome
454200-25SC	Amber LEDs with Clear dome
454200-35SC	Blue LEDs with Clear dome
454200-45SC	Red LEDs with Clear dome
454200-65SC	Green LEDs with Clear dome
454200-24-02SC	24 VDC, Amber LEDs with Amber dome
454200-24-25SC	24 VDC, Amber LEDs with Clear dome

**Permanent mount**

454201-02SC	Amber LEDs with Amber dome
454201-03SC	Blue LEDs with Blue dome
454201-04SC	Red LEDs with Red dome
454201-05SC	White LEDs with Clear dome
454201-06SC	Green LEDs with Green dome
454201-25SC	Amber LEDs with Clear dome
454201-35SC	Blue LEDs with Clear dome
454201-45SC	Red LEDs with Clear dome
454201-65SC	Green LEDs with Clear dome
454201-24-02SC	24 VDC, Amber LEDs with Amber dome
454201-24-25SC	24 VDC, Amber LEDs with Clear dome

*Magnetic mount models, include cigarette plug with on-off switch*

454202-02SC	Amber LEDs with Amber dome
454202-03SC	Blue LEDs with Blue dome
454202-04SC	Red LEDs with Red dome
454202-05SC	White LEDs with Clear dome
454202-06SC	Green LEDs with Green dome
454202-25SC	Amber LEDs with Clear dome
454202-35SC	Blue LEDs with Clear dome
454202-45SC	Red LEDs with Clear dome
454202-65SC	Green LEDs with Clear dome
454202-24-02SC	24 VDC, Amber LEDs with Amber dome
454202-24-25SC	24 VDC, Amber LEDs with Clear dome

**Split-color models**

*Suction-cup magnet mount models, include cigarette plug with on/off switch*

454300C-AB	Amber/Blue LEDs
454300C-AR	Amber/Red LEDs
454300C-AW	Amber/White LEDs
454300C-BA	Blue/Amber LEDs
454300C-BR	Blue/Red LEDs
454300C-RA	Red/Amber LEDs
454300C-RB	Red/Blue LEDs
454300C-RW	Red/White LEDs
454300CS-BWB	Blue/White/Blue LEDs
454300CS-RWR	Red/White/Red LEDs

Model	Description
-------	-------------

**Permanent mount models**

454301C-AA	Amber/Amber LEDs
454301C-AB	Amber/Blue LEDs
454301C-AR	Amber/Red LEDs
454301C-BR	Blue/Red LEDs
454301C-BW	Blue/White LEDs
454301C-RA	Red/Amber LEDs
454301C-RB	Red/Blue LEDs
454301C-RW	Red/White LEDs
454301CS-00005	White/Amber/White LEDs

*Magnetic mount models, include cigarette plug with on/off switch*

454302C-AR	Amber/Red LEDs
454302C-BA	Blue/Amber LEDs
454302C-BR	Blue/Red LEDs
454302C-BW	Blue/White LEDs
454302C-RA	Red/Amber LEDs
454302C-RB	Red/Blue LEDs
454302C-RW	Red/White LEDs

**Accessories and Kits**

SW2	Switch control
Z8560109A	Magnet Select keychain

**Common Replacement Parts**

Z8560095B-02	Dome, LED HighLighter, Amber; -03(Blue); -04(Red); -05(Clear)
Z124161A	Kit, Base, LED HighLighter

**Notes**

- If ordering a dome for a unit older than Series C, you must order a base kit (Z124161A).
- See page 6 for HighLighter mounting kits
- See page 53 for mounting bar options

## HighLighter™ LED Economy

- Low-profile, only 2.6" tall; 15" long
- Offered in Amber LEDs only
- Dome available in Amber and Clear
- Five-year LED warranty



454205-025C



Model	Description
	<b>Suction-cup magnet mount models, includes cigarette plug with on/off switch</b>
454204-025C	Amber LEDs with Amber dome
454204-255C	Amber LEDs with Clear dome
	<b>Permanent Mount Models</b>
454205-025C	Amber LEDs with Amber dome
454205-255C	Amber LEDs with Clear dome
	<b>Magnetic Mount Models</b>
454206-025C	Amber LEDs with Amber dome
454206-255C	Amber LEDs with Clear dome

### Notes

- See page 6 for HighLighter mounting kits.
- See page 53 for mounting bar options.

## HighLighter™

- Two 55-watt halogen reflectors produce an effective 80,000 candelas each
- Compact size - 15" long
- Special thick filament bulb
- Permanent or magnetic mount options for ease of installation
- Domes available in Amber, Blue, Clear, Green, and Red
- Five-year product warranty



(permanent mount shown)



Model	Description
	<b>Permanent mount</b>
450112-02	(2) 95 FPM rotators, diagonal mirror; Amber; -03(Blue); -04(Red); -05(Clear)
450114-02	(2) 95 FPM rotators, diagonal mirror, 24 VDC; Amber; -03(Blue); -04(Red)
450152-02	(2) 120 FPM rotators, diagonal mirror; Amber; -03(Blue); -04(Red); -05(Clear)
452112-02	(2) 95 FPM rotators, diamond mirror; Amber; -03(Blue); -04(Red); -05(Clear)
451112-02	(2) 175 FPM rotators, diagonal mirror; Amber; -03(Blue); -04(Red); -05(Clear)
	<b>Magnetic mount, includes cigarette plug</b>
452142-02	(2) 95 FPM rotators, diagonal mirror; Amber; -03(Blue); -04(Red); -05(Clear)
452162-02	(2) 120 FPM rotators, diagonal mirror; Amber; -03(Blue); -04(Red); -05(Clear)
452412-02	(2) 175 FPM rotators, diagonal mirror; Amber; -03(Blue); -04(Red); -05(Clear)
452643-02	(2) 95 FPM rotators, diamond mirror; Amber; -03(Blue); -04(Red); -05(Clear)
	<b>Suction-cup magnetic mount, includes cigarette plug</b>
450142-02	(2) 95 FPM rotators, diagonal mirror; Amber; -03(Blue); -04(Red); -05(Clear)
450144-02	(2) 95 FPM rotators, diagonal mirror, 24 VDC; Amber
450162-02	(2) 120 FPM rotators, diagonal mirror; Amber; -03(Blue); -04(Red); -05(Clear)
451412-02	(2) 175 FPM rotators, diagonal mirror; Amber; -03(Blue); -04(Red); -05(Clear)
452642-02	(2) 95 FPM rotators, diamond mirror; Amber; -04(Red); -05(Clear)
452642-02	(2) 95 FPM rotators, diamond mirror; Amber; -04(Red); -05(Clear)

### Accessories and Kits

DCK	Kit, dome cover, specify color, -A(Amber); -R(Red)
SPL2	Kit, rotator lens, specify color, -A(Amber); -B(Blue); -G(Green); -R(Red)

### Common Replacement Parts

Z8440A265A-02	Bulb, 55W, halogen, long life
439231-95	Bulb, 24 VDC
447532	Motor, 95 FPM, 12 VDC
447542	Motor, 120 FPM, 12 VDC
447539	Motor, 175 FPM, 12 VDC
447534	Motor, 95 FPM, 24 VDC
447544	Motor, 175 FPM, 24 VDC
448572	Rotator, 95 FPM, 12 VDC
Z8433008B-07	Rotator, 120 FPM, 12 VDC
448522	Rotator, 175 FPM, 12 VDC
448514	Rotator, 95 FPM, 24 VDC
448524	Rotator, 175 FPM, 24 VDC
452510-02	Dome, HighLighter; Amber; -03(Blue); -04(Red); -05(Clear)

### Notes

- See page 6 for HighLighter mounting kits.
- See page 53 for mounting bar options.



# HighLighter™ Strobe

- Compact Size - 15" long
- Fully-encapsulated (potted) 40-watt power supply with eight user selectable flash patterns
- Automatic or manual hi-low feature for day or night operations
- Silicone rubber strobe tubes to absorb vibration
- Three mount options available: permanent, magnetic and suction-cup magnetic
- Raised base makes installation and maintenance quick and easy
- Five-year product warranty



CLASS 1

Model	Description
	<b>Permanent mount</b>
453001-02SB	(2) strobe heads, diagonal mirror, 20W; Amber; -04(Red); -05(Clear); -25(Clear dome with Amber and Clear strobe domes)
453003-02SB	(2) strobe heads, diamond mirror, 20W; Amber
453201-02	(2) strobe heads, diagonal mirror, 40W; Amber; -03(Blue); -04(Red); -05(Clear); -25(Clear domes with Amber and Clear strobe domes); -45(Clear dome with Red and Clear strobe domes)
	<b>Magnetic mount, include cigarette plug</b>
453000-02SB	(2) strobe heads, diagonal mirror; Amber; -04(Red); -05(Clear); -25(Clear dome with Amber and Clear strobe domes)
453002-02SB	(2) strobe heads, diamond mirror; Amber
453202-02	(2) strobe heads, diagonal mirror, 40W; Amber; -03(Blue); -04(Red); -05(Clear)
	<b>Suction-cup magnetic mount, includes cigarette plug</b>
453200-02	(2) strobe heads, diagonal mirror, 40W; Amber; -03(Blue); -04(Red); -05(Clear); -25(Clear dome with Amber and Clear strobe domes)

### Accessory

SW2 Switch control

### Common Replacement Parts

Z8560081A	Power supply, 40W
Z8560082A	Strobe assembly
208669-95	Dome, fresnel, strobe (under dome)
452510-02	Dome, HighLighter; Amber; -03(Blue); -04(Red); -05(Clear)

### Notes

- See below for HighLighter mounting kits.
- See page 53 for mounting bar options.

## Mounting Kits - For use with HighLighter LED, HighLighter LED Economy, HighLighter and HighLighter Strobe

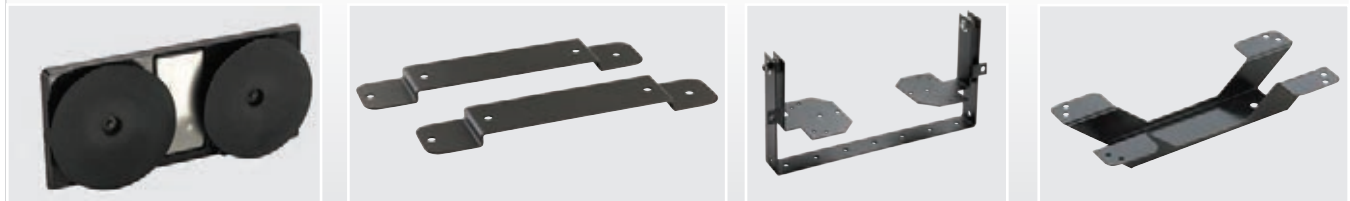

452341

454218

210883

454217

Model	Description
452340	Kit, magnetic mount, cigarette plug included
452341	Kit, suction cup magnetic mount, cigarette plug included
452342	Kit magnetic mount, cigarette plug not included
454217	Kit, riser mount
454218	Kit, flat mount
210883	Self-leveling bracket

## 24" Legend®

- Low-profile, linear lightbar design offers front and rear cut-off and dimming features
- Patented ROC (Reliable Onboard Circuitry™) eliminates approximately 85% of the potential failure points in a typical lightbar
- Optimized Solaris® LED reflector maximizes warning lights at 360-degrees and 90-degrees off-axis
- Advanced microprocessor controller provides three modes of operation and a library of flash patterns
- LEDs offered in Amber, Blue, Green, Red, and White
- Top dome colors are offered in Amber and Clear
- Six-button and/or three-button serial controller available for light control only
- Five-year LED warranty



Model	Description
	<b>24" Model - Permanent mount and 3-button controller included</b>
LGD24-00107	Clear/Clear, (4) Amber corner LED reflectors, (4) Amber 5" LED reflectors, (2) Amber 2" LED reflectors
	<b>24" Models - Flat mount and 6-button controller included</b>
LGD24-00001	Clear/Clear, (4) Amber corner LED reflectors, (4) Amber 5" LED reflectors, (2) Amber 2" LED reflectors
LGD24-00026	Amber/Amber, (4) Amber corner LED reflectors, (4) Amber 5" LED reflectors, (2) Amber 2" LED reflectors
LGD24-00018	Clear/Clear, (4) Amber corner LED reflectors
LGD24-00046	Amber/Amber, (4) Amber corner LED reflectors
	<b>24" Models - Permanent mount and 6-button controller included</b>
LGD24-00036	Clear/Clear, (4) Amber corner LED reflectors, (4) Amber 5" LED reflectors, (2) Amber 2" LED reflectors
LGD24-00035	Amber/Amber, (4) Amber corner LED reflectors, (4) Amber 5" LED reflectors, (2) Amber 2" LED reflectors
LGD24-00047	Clear/Clear, (4) Amber corner LED reflectors
LGD24-00048	Amber/Amber, (4) Amber corner LED reflectors

### Accessories and Kits

660000	6-button programmable controller, light control only
660300	3-button programmable controller, light control only
660100	RS485 relay module
HKB-(Model)	Hook required with hook-on mount, specify vehicle—see page 21
Z8653134B	Hook mount kit
Z8653134B-01	Permanent mount kit
Z8653178A	Flat surface mount kit

### Note

- See page 67 for common replacement parts.

### How to order

Choose one of the popular models above, customize your own lightbar with our online configurator or contact a local Federal Signal representative or distributor.



## 21" Mini-JetSolaris®

- All models feature Solaris® LED reflector technology for superior light performance
- Utilizes innovative patented ROC (Reliable Onboard Circuitry™) technology
- Twenty-six user-selectable patterns with primary/secondary modes
- LEDs offered in Amber, Blue, Green, Red, and White
- Cigarette plug power option available
- Five-year LED warranty



JLX2106C-HD

CLASS 1

Online Lightbar Configurator

ROC  
RELIABLE ONBOARD CIRCUITRY™

SOLARIS

Model	Description
	<b>21" Mini-JetSolaris - Mount kit included</b>
JLX2101-HD	Amber, (2) Amber 6-LED reflectors, (6) Amber 3-LED reflectors
JLX2101C-HD	Clear, (2) Amber 6-LED reflectors, (6) Amber 3-LED reflectors
JLX2106-HD	Amber, (6) Amber 6-LED reflectors, (6) Amber 3-LED reflectors
JLX2106C-HD	Clear, (6) Amber 6-LED reflectors, (6) Amber 3-LED reflectors
JLX2192-HD	Clear, (6) Amber 6-LED reflectors, (6) Amber 3-LED reflectors, cigarette plug included
<b>Kits</b>	
JMPK	Kit, permanent mount, 21" Mini-Jet models
JMMK	Kit, magnetic mount

### How to order

Choose one of the popular models above, customize your own lightbar with our online configurator or contact a local Federal Signal representative or distributor.



JMPK



JMMK



## 12" Legend® Sets

- Optimized Solaris® LED reflector maximizes warning lights at 360-degrees and 90-degrees off-axis
- Patented ROC (Reliable Onboard Circuitry™) eliminates approximately 85% of the potential failure points in a typical lightbar
- 20-ft traditional cable
- Built-in flasher models include (10) selectable flash patterns
- Five-year LED warranty



Model	Description
	<b>Flat Mount Included</b>
LGD12-00001	Clear, (2) Amber corner LED reflectors, (2) Amber 5" LED reflectors, (1) Amber 2" reflector, built-in flasher, set
LGD12-00002	Clear, (2) Amber corner LED reflectors, (2) Amber 5" LED reflectors, (1) Amber 2" reflector, set

### Accessories and Kits

660100	RS485 relay module
650205	Flasher, (2) 10A loads, (10) flash patterns, high-side switching

### Note

- See page 67 for common replacement parts.

## 9" MicroEscape®

- Solaris® LED reflector technology provides superior light performance
- Built-in Intelli-flash LED flasher
- Two flashing modes each with the ability to select one of 10 flash patterns
- Permanent mount kit included
- Five-year LED warranty



ME4QL-A



Model	Description
ME4QL-A	9", Amber Dome, (4) Amber LED reflectors, set
ME4QLC-A	9", Clear Dome, (4) Amber LED reflectors, set

### Kit

501430	Kit, FMK flat surface mount
--------	-----------------------------

### Common Replacement Parts

Z8003245A-02	PC board assembly, non-flasher, Amber
Z8003245A-08	PC board assembly, non-flasher, White

# TurboBeam® Mini-Lightbar

- Powerful 80,000-candela halogen rotators
- Optional diamond mirrors double flash rate
- Available in 15" and 22" lengths with flush or raised bases
- Five-year product warranty



415010-02SC

CLASS 1

Model	Description
<b>15" Models - 12 VDC, (2) rotators, flush base</b>	
211906-02SC	Diamond mirror, magnetic mount, Amber; -03(Blue); -04(Red); -43(Red/Blue)
415010-02SC	Permanent mount, Amber; -03(Blue); -04(Red); -05(Clear); -34(Blue/Red)
415011-02SC	Diamond mirror, permanent mount, Amber; -03(Blue); -04(Red); -05(Clear); -23(Amber/Blue); -24(Amber/Red); -25(Amber/Clear); -43(Red/Blue)
<b>15" Model - 24 VDC, (2) rotators, flush base</b>	
211900-02SC	Permanent mount, Amber; -03(Blue); -04(Red)
<b>15" Model - 12 VDC, (2) rotators, raised base</b>	
415510-02SB	Permanent mount, Amber; -03(Blue); -04(Red); -05(Clear); -52(Clear/Amber)
<b>22" Models - 12 VDC, (2) rotators, diamond mirror, flush base</b>	
211914-02SC	Magnetic mount, Amber; -04(Red); -353(Blue/Clear/Blue)
415111-02SC	Permanent mount, Amber; -03(blue); -04(Red); -05(Clear); -06(Green); -242(Amber/Red/Amber); -252(Amber/Clear/Amber)
<b>22" Model - 12 VDC, (2) rotators, diamond mirror, raised base</b>	
415611-02SB	Permanent mount, Amber; -03(Blue); -04(Red); -242(Amber/Red/Amber); -252(Amber/Clear/Amber)

### Accessories and Kits

SPL2	Filter, rotator, specify color, -A(Amber); -B(Blue); -G(Green); -R(Red); (only compatible with all raised base and 22" flush base models)
210386B	Kit, wiring install
210897B	Kit, magnetic mount for flush mount base models only
510450	Kit, magnetic mount for raised base models only

### Common Replacement Parts

AHRK	Rotator, 95 FPM
AHRK-F	Rotator, 175 FPM
411167	Right-side dome, Amber
411177	Center dome, Amber
411187	Left-side dome, Amber



211900-02SC  
415010-02SC  
415510-02SB

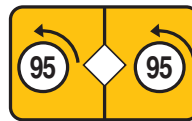

211906-02SC  
415011-02SC

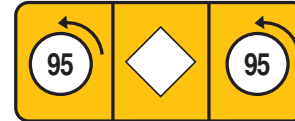

211914-02SC  
415111-02SC  
415611-02SB



SPL2-A



210897B



510450

**LED Mini-Lightbars**

Model	Operating Voltage	Amp Draw	FPM	Flash Patterns	Approvals	Base Material	LED Colors	Dome Colors	Dimensions (L x W x H)	Ship Weight (lbs)	Warranty (years)
24" Legend	12	4.0A @ 12.8 V	Various	Various	Class 1	Aluminum	Amber, Blue, Green, Red and White	Amber and Clear	24.25" x 11.2" x 2.5"	10.8	5
12" Legend	12	2.5A @ 12.8 V	Various	10	Class 1	Aluminum	Amber, Blue, Green, Red and White	Amber and Clear	12" x 11.2" x 2.5"	10.8	5
Mini-JetSolaris	12	2.0A @ 12 V	Various	26	Class 1	Aluminum	Amber, Blue, Green, Red and White	Amber, Blue, Clear and Red	21.0" x 11.2" x 4.7"	16.0	5
HighLighter LED	12 or 24	2.0A @ 12.8 V 1.0A @ 25.6 V	Various	21	Class 1	Polycarbonate	Amber, Blue, Green, Red and White	Amber, Blue, Clear, Green and Red	15.3" x 8.4" x 3.0"	6.0	5
9" MicroEscape	12	6A @ 12 V	Various	10	Class 1	Aluminum	Amber, Blue and Red	Amber, Clear and Red	9.0" x 10.5" x 4.5"	7.8	5

**Strobe Mini-Lightbars**

Model	Operating Voltage	Amp Draw	Joules	Watts	FPM	Approvals	Base Material	Dome Colors	Dimensions (L x W x H)	Ship Weight (lbs)	Warranty (years)
HighLighter Strobe	12	3.6A @ 12V	35/22 Hi-Lo (default)	40/24 (default)	65 (default)	Class 1	Polycarbonate	Amber, Blue, Clear, Green and Red	15.0" x 9.0" x 5.0"	5.0	5

**Rotating Mini-Lightbars**

Model	Operating Voltage	Amp Draw	Lamp	Candelas	FPM	Approvals	Base Material	Dome Colors	Dimensions (L x W x H)	Ship Weight (lbs)	Warranty (years)
HighLighter	12/24	8.6 @ 12V; 5.8 @ 24V	55/70	80,000	285-525	Class 1 Title 13	Polycarbonate	Amber, Blue, Red, Clear and Green	15.8" x 7.0" x 5.3"	5.0	5
Mini-Jet	12/24	8.6 @ 12V; 5.6 @ 24V	55/70	55,000	380/555	Class 1 Title 13	Aluminum	Various	21.0" x 11.2" x 4.7"	10.0	5
TurboBeam Mini-Lightbar	12/24	8.6 @ 12V; 5.6 @ 24V	55/70	80,000	190/380	Class 1	Aluminum	Amber, Blue, Red, Clear and Green	15.0" x 9.0" x 5.0" (15") 22.0" x 9.0" x 5.0" (22")	5 (15") 6 (22")	5

# SLR Beacon

- Rotating LED beacon with 12 high-powered LEDs
- Federal Signal's patented Solaris® LED rotator technology
- 75/90/120 RPM
- 12/24 VDC
- Five-year LED warranty



CLASS 1 CLASS 2 SLR®

Model	Description
	<b>Models with permanent/pipe mount</b>
262650-02	Amber LEDs, Amber dome, permanent/pipe mount, -04(Red), Class 1
272650-02	Amber LEDs, Amber dome, permanent/pipe mount, -04(Red), Class 2

**Note**

- See page 53 for roof mounting bar options

Model	Operating Voltage	Amp Draw	RPM	Approvals	Base Material	Dome Colors	Dimensions (D x H)	Ship Weight (lbs)	Warranty (years)
SLR Beacon	12/24	1.8A @ 12.8V	75/90/120	Class 1 & 2	Polycarbonate/ aluminum	Amber, Clear and Red	5.75" x 7.09"	2.75 (perm.)	5

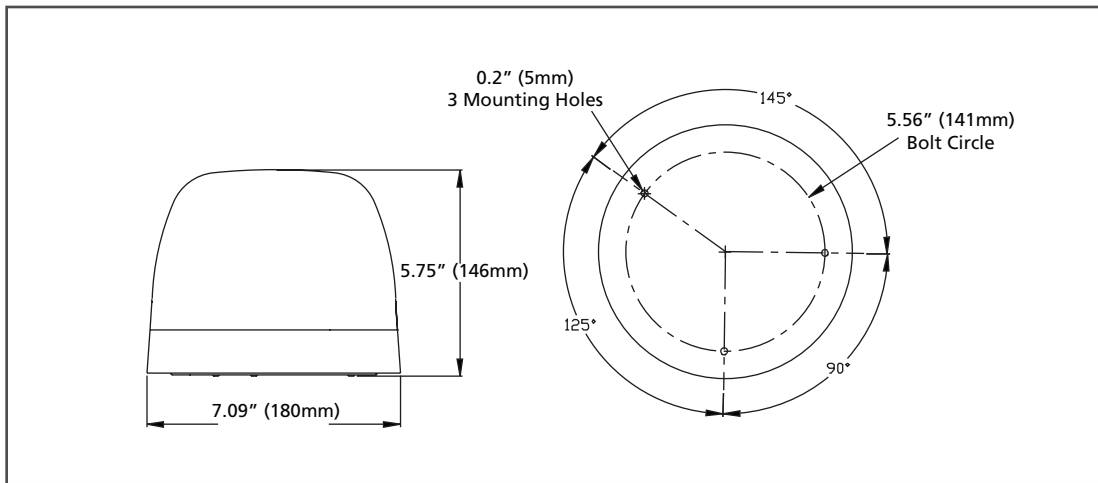

# UltraStar® LED

- LED UltraStar® provides superior optics for maximized light output
- Die-cast aluminum base
- Twelve selectable “strobing” patterns
- Industry standard mounting for quick and easy retrofits
- SAE J845 Class 1 approved
- Five-year LED warranty



**CLASS 1**

Model	Description
<b>Models with 1-inch permanent/pipe mount</b>	
252650-02SB	Amber LEDs with Amber dome
252654-04SB	Red LEDs with Red dome
252657-02SB	Amber LEDs with Amber dome and dust cover
<b>Models with magnet mount and cigarette plug</b>	
252651-02SB	Amber LEDs with Amber dome
252655-04SB	Red LEDs with Red dome

### Accessories and Kits

SW2	Switch control
448330	MZDGK branch guard

### Common Replacement Parts

Z8444374A	Dome, short, -01(Clear); -02(Red); -03(Amber); -04(Blue)
Z8444375A-01	Dust cover, short, Clear
Z8444313C	Light shield
Z8444397A	J-bolt mounting kit

### Note

- See page 53 for roof mounting bar options.

Model	Operating Voltage	Amp Draw	FPM	Flash Patterns	Approvals	Base Material	Dome Colors	Dimensions (D x H)	Ship Weight (lbs)	Warranty (years)
UltraStar LED	12/24	1.2A @ 12.8 V	Various	12	Class 1	Aluminum	Amber, Blue, Clear, Green and Red	6.5" x 5.25"	2.75 (perm.) 3.5 (mag.)	5

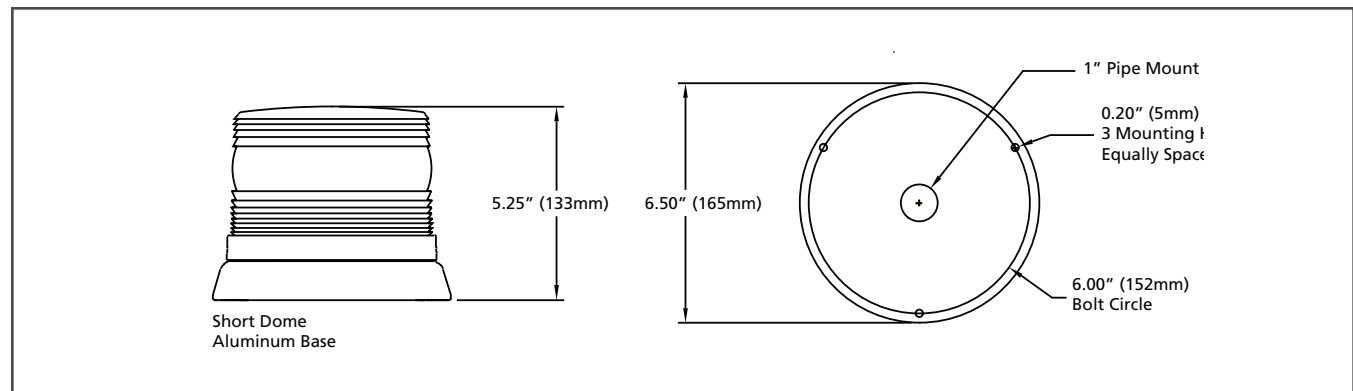

# Pulsator® LED

- LEDNode™ technology for zero maintenance
- Black polycarbonate plastic base
- Ten selectable “strobing” flash patterns
- Permanent mount kit included
- SAE J845 Class 1 approved and SAE J845 Class 2 approved models
- Five-year LED warranty



**CLASS 1** **CLASS 2**

Model	Description
	<b>Permanent Mount, 12-24 VDC</b>
212650-02	Amber LED, Amber dome, Class 2
212650-25	Amber LED, Clear dome, Class 2
212650-03	Blue LED, Blue dome, Class 2
212650-04	Red LED, Red dome, Class 2
212660-02	Amber LED, Amber dome, Class 1
212660-25	Amber LED, Clear dome, Class 1

### Accessories and Kits

SW2	Switch control
210890	Kit, magnetic mount
210891	Kit, self-adhesive mounting
210893	1/2" pipe mount
210894	3/4" pipe mount
210895	1" pipe mount

### Common Replacement Parts

208666-95	Dome, tall, Blue
208667-95	Dome, tall, Amber
208668-95	Dome, tall, Red
208669-95	Dome, tall, Clear

### Note

- See page 53 for roof mounting bar option.

Model	Operating Voltage	Amp Draw	FPM	Flash Patterns	Approvals	Base Material	Dome Colors	Dimensions (D x H)	Ship Weight (lbs)	Warranty (years)
Pulsator LED	12/24	0.80A @ 12.8 V 0.40A @ 25.6 V	Various	10	Class 1 & 2	Polycarbonate	Amber, Blue, Clear, Green and Red	6.5" x 6.0"	1.9	5

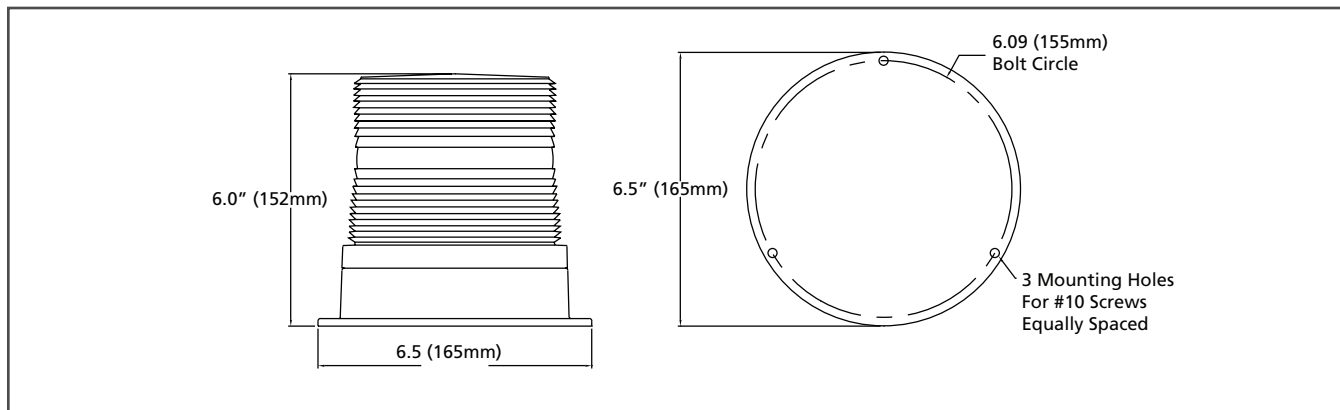

# Model 651 LED

- "Open-style" aluminum base
- Built-in flash patterns
- Low amp draw
- SAE J845 Class 2 approved
- Five-year LED warranty



420222-02

CLASS 2

Model	Description
420222-02	UTILITY LIGHT, blackout lens, clear dust cover, branch guard, Amber LED, Amber dome
420223-02	Open style bottom, Amber LED, Amber dome

### Accessories and Kits

210781	Wire branch guard (used on 651 Plus and 651 AUL models)
210939	"L" mounting bracket
210830	Polycarbonate 1" pipe/flush mount bottom
210982	Aluminum 1" pipe/flush mount bottom
210831	Kit, polycarbonate flush magnetic mount
210050	Kit, aluminum flush magnetic mount
210837	1" to 1/2" pipe adapter for 210830 and 210982
210838	1" to 3/4" pipe adapter for 210830 and 210982
210846	Aluminum flush enclosed bottom
210923	Aluminum raised enclosed bottom
210928	Magnetic mount kit for aluminum/polycarbonate mount bottoms
210877	Dust cover with black top
200765-95	Polycarbonate dust cover without black cover

### Common Replacement Parts

205003-95	Gasket, base
205004-95	Gasket, dome
208551-95	Base
438694-95	Kit, mounting
200767-95	Dome, Amber
200768-95	Dome, Clear

Model	Operating Voltage	Amp Draw	FPM	Flash Patterns	Approvals	Base Material	Dome Colors	Dimensions (D x H)	Ship Weight (lbs)	Warranty (years)
651 LED	12/24	1A @ 12.8 V	Various	4	Class 2	Aluminum	Amber	6.51" x 5.4" 6.51" x 6.05" (Wire Branch Guard)	2	5

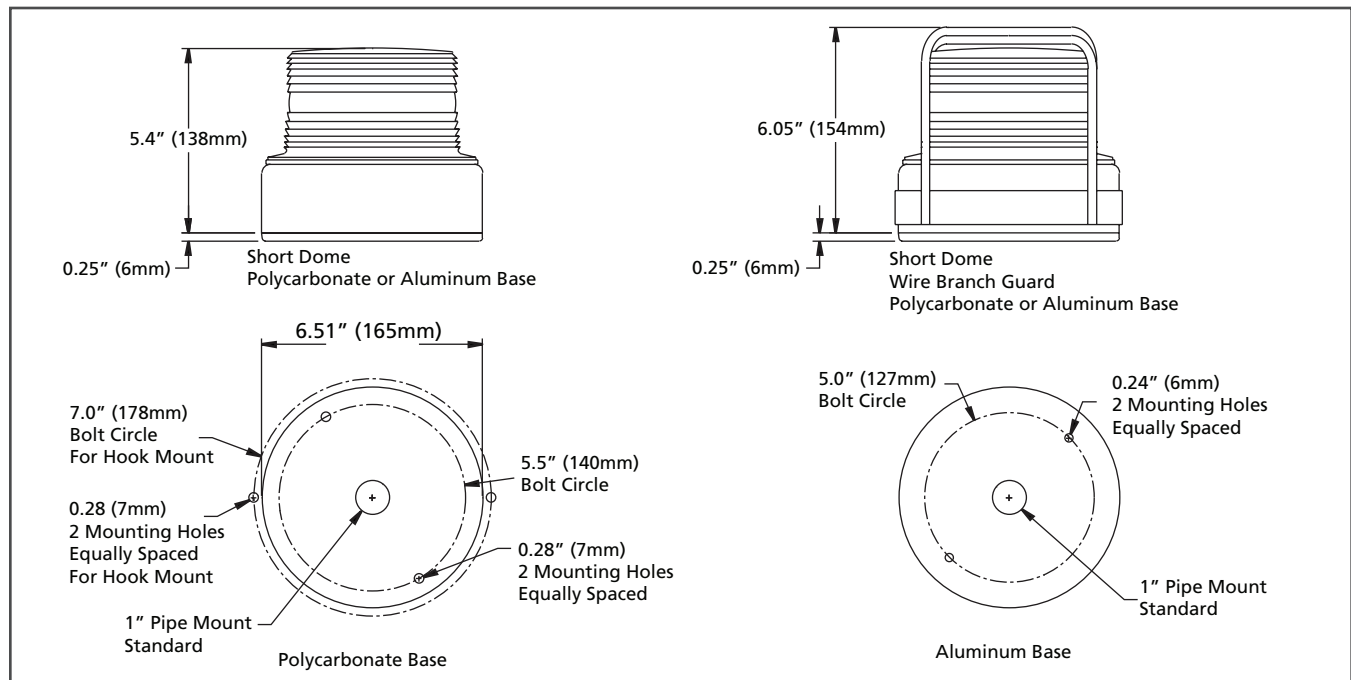

# AL2

- Electronics are encapsulated in a durable steel enclosure using a high-temperature range silicone potting compound for dependable operation
- Offers (4) built-in, user-selectable flash patterns
- Operates at 12 or 24 VDC
- High-profile design, with a sturdy polycarbonate dust cover, provide for a robust warning solution
- Clear-anodized aluminum base for chrome-plated aluminum base models available
- Five-year product warranty



211779-02

**CLASS 2**

Model	Description
211779-02	AL2, LED, anodized aluminum base, Amber
211781-02	AL2, LED, chrome-plated base, Amber

Model	Operating Voltage	Amp Draw	FPM	Flash Patterns	Approvals	Base Material	Dome Colors	Dimensions (D x H)	Ship Weight (lbs)	Warranty (years)
AL2	12/24	1A @ 12.8 V	Various	4	Class 2	Aluminum or Chrome-plated Aluminum	Amber	9.0" x 8.6"	3.8	5

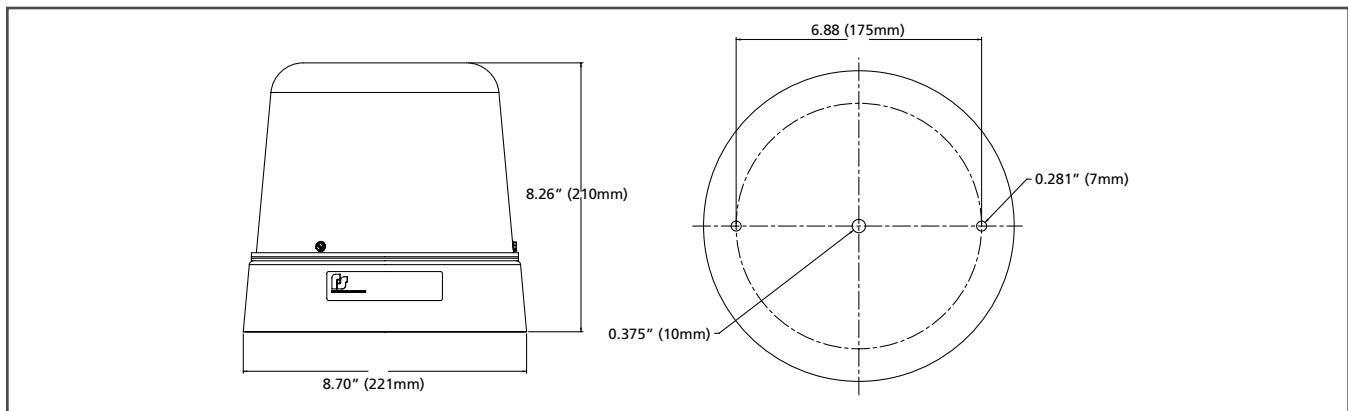



# AS2

- Electronics are encapsulated in a durable steel enclosure using a high-temperature range silicone potting compound for dependable operation
- Provides an 80-FPM double-flash warning signal
- Automatically adjusts to any voltage from 12-48 VDC
- High-profile design, with a sturdy polycarbonate dust cover, provide for a robust warning solution
- Clear-anodized aluminum base for chrome-plated aluminum base models available
- Five-year product warranty



211780-02

**CLASS 2**

Model	Description
211778-02	AS2, strobe, anodized aluminum base, Amber
211780-02	AS2, strobe, chrome-plated base, Amber

Model	Operating Voltage	Amp Draw	Joules	Watts	FPM	Approvals	Base Material	Dome Colors	Dimensions (D x H)	Ship Weight (lbs)	Warranty (years)
AS2	12/24	1.65A @ 12 V	12	16	80	Class 2	Aluminum or Chrome-plated Aluminum	Amber	9.0" x 8.6"	3.8	5

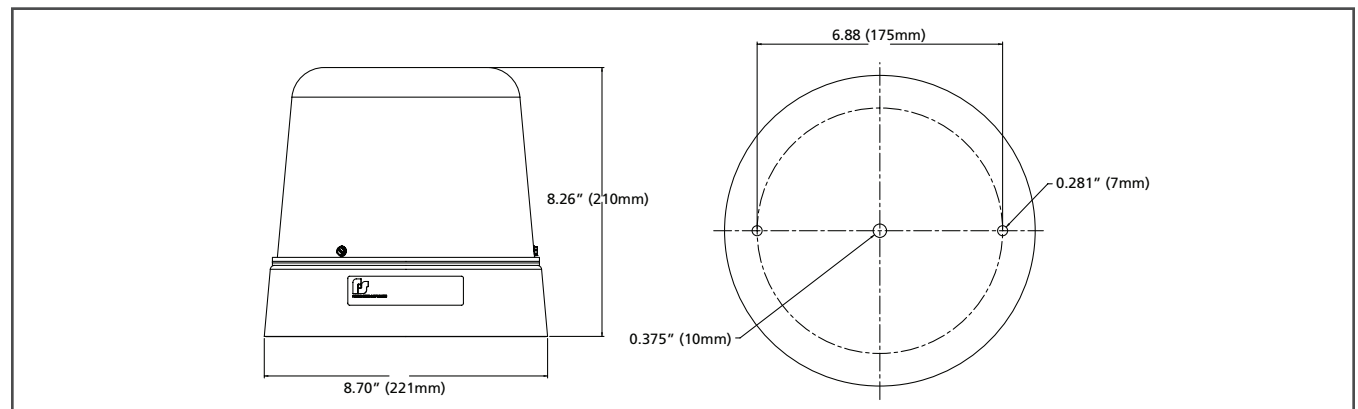

## UltraStar® US 5, US 6 and US 7

- Powder coated aluminum die-cast base
- Shock-mounted strobe tube
- Industry standard mounting: permanent/1" pipe, magnetic and J-bolt
- Five-year product warranty

### US 5

- 13 Joules, double flash and 14 Joules, quad flash
- SAE J845 Class 1 approved (SAE J1318, Class 1, 2009) tall dome models
- SAE J845 Class 2 approved (SAE J1318, Class 1, 2009) short dome models

### US 6

- 17/12 Joules, double flash
- Built-in photocell provides automatic adjustment to ambient light for day or night operation (may be converted to a manual [switchable] adjustment)
- SAE J845 Class 1 approved (SAE J1318, Class 1, 2009)
- Potted, fully-encapsulated power supply

### US 7

- Power supply produces 21 Joules
- Built-in photocell provides automatic adjustment to ambient light for day or night operation (may be converted to a manual [switchable] adjustment)
- SAE J845 Class 1 approved (SAE J1318, Class 1, 2009)
- Potted, fully-encapsulated power supply



CLASS 1 CLASS 2

Model	Description
250121-02	<b>US 5, 13-Joules, 12-24 VDC, 18.4W, double flash, tall dome</b> Permanent/pipe mount, Amber; -03(Blue); -04(Red); -05(Clear), Class 1
250141-02	Magnetic mount, Amber; -03(Blue); -04(Red); -05(Clear), Class 1
251121-02	<b>US 5, 13-Joules, 12-24 VDC, 18.4W, double flash, short dome</b> Permanent/pipe mount, Amber; -03(Blue); -04(Red); -05(Clear), Class 2
251141-02	Magnetic mount, Amber; -03(Blue); -04(Red); -05(Clear), Class 2
252600-02	<b>US 6, 17/12-Joules, 12-24 VDC, 21.3/15W, double flash</b> Permanent/1" pipe mount, Amber; -03(Blue); -04(Red); -05(Clear), Class 1
252601-02	Magnetic mount, Amber; -03(Blue); -04(Red); -05(Clear), Class 1
250721-02	<b>US 7, 21/13-Joules, 12-24 VDC, 26.3/16.3W, quad flash, tall dome</b> Permanent/pipe mount, Amber; -03(Blue); -05(Clear), Class 1
250741-02	Magnetic mount, Amber; -03(Blue); -05(Clear), Class 1

### Accessories and Kits

SW2	Switch control
448310	Kit, vibration mount
448320	MZDGP pipe mount adapter for 448330 branch guard
448330	MZDGK branch guard
Z8444373A-01	Dust cover, tall dome, Clear
Z8444375A-01	Dust cover, short dome, Clear

### Common Replacement Parts

251500	Flash tube, US5
251501	Flash tube, US7
250520	Double flash power supply, US5
Z8444372A	Dome, tall; -01(Clear); -02(Red); -03(Amber); -04(Blue)
Z8444374A	Dome, short; -01(Clear); -02(Red); -03(Amber); -04(Blue)
Z8575272A	Flash tube assembly, US6

### Note

- See page 53 for roof mounting bar options.

Model	Operating Voltage	Amp Draw	Joules	Watts	FPM	Approvals	Base Material	Dome Colors	Dimensions (D x H)	Ship Weight (lbs)	Warranty (years)
UltraStar US 5	12/24	1.8A @ 12V to 0.9A @ 24V	13/14	18.4/19	85/80	Class 1 & 2	Aluminum	Amber, Blue, Clear, and Red	6.5" x 6.74" (Tall) 6.5" x 5.25" (Short)	4.0	5
UltraStar US 6	12/24	2.0A @ 12.8V to 1.2A @ 25.6V (high) 1.6A @ 12.8V to 0.8A @ 25.6V (low)	17/12	17/12	75	Class 1	Aluminum	Amber, Blue, Clear, and Red	6.5" x 6.7" (Perm.) 6.5" x 6.9" (Mag.)	4.25 (Perm.) 4.95 (Mag.)	5
UltraStar US 7	12/24	2.5A @ 12V to 1.2A to 24V	21/13 Hi-Lo	21.3/15	75	Class 1	Aluminum	Amber, Blue, Clear, and Red	6.5" x 6.74" (Tall)	4.0	5

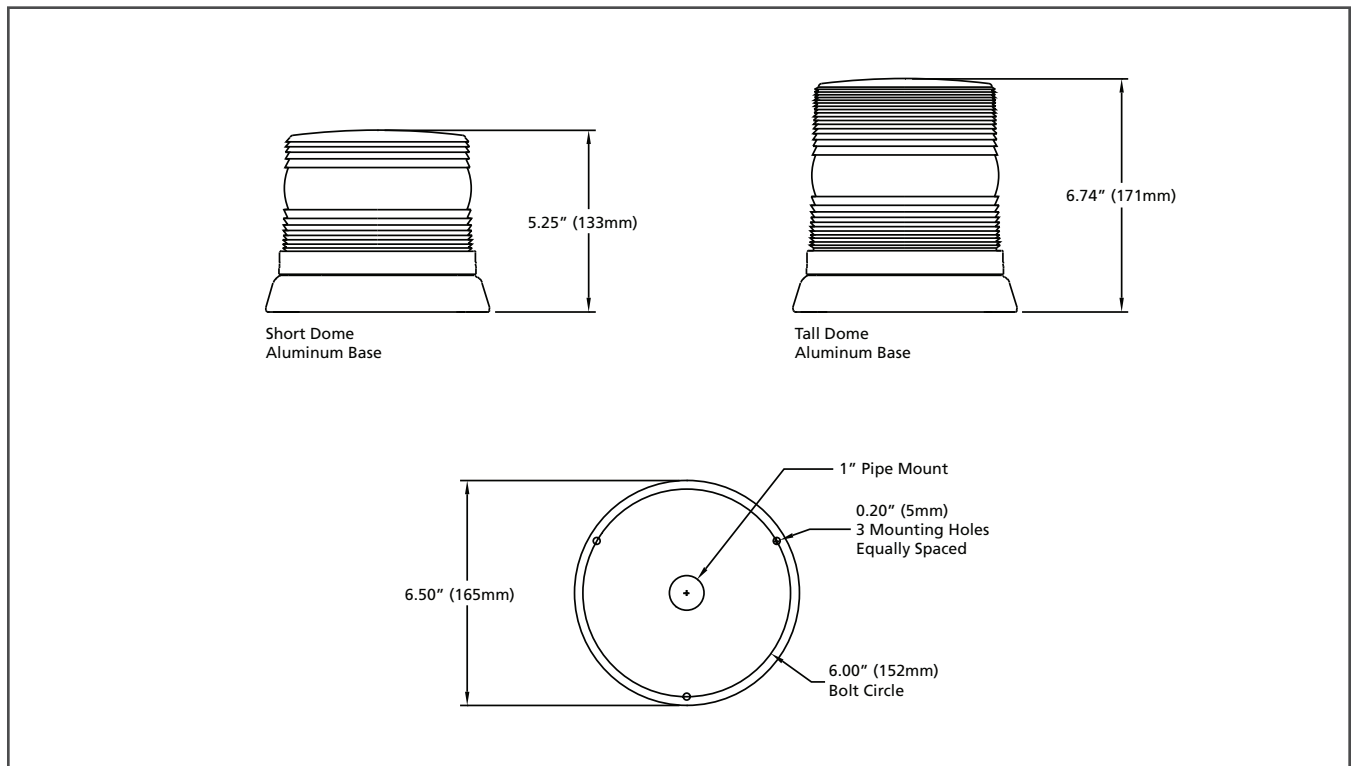

448330



448320

# Model 901/951

- Automatic adjustment to function at any voltage from 12-48VDC
- Open-style aluminum base
- Attached dust cover
- High- (Model 951) and low- (Model 901) profile strobe beacon
- SAE J845 Class 1 approved (SAE J1318 Class 1, 2009)
- Built-in high/low flash option
- Five-year product warranty



**CLASS 1**

Model	Description
	<b>Model 901</b>
	<i>18J, 21.3W, 12-48VDC, double flash, hi/low</i>
211740-02	Open-style bottom, Amber; -03(Blue); -04(Red); -05(Clear)
	<b>Model 951</b>
	<i>18J, 21.3W, 12-48VDC, double flash, hi/low</i>
211742-02	Open-style bottom, Amber; -03(Blue); -04(Red); -05(Clear)
211749-02	Aluminum 1" pipe/flush mount bottom, Amber; -03(Blue); -05(Clear)
211754-02	UTILITY LIGHT, blackout lens, clear dust cover, branch guard, and aluminum 1" pipe/flush mounting base, Amber

### Accessories and Kits

	<b>Model 901 only</b>
200765-95	Polycarbonate dust cover without black cover
210781	Wire branch guard
210877	Dust cover with black top
	<b>Model 951 only</b>
200776-95	Polycarbonate dust cover without black cover
210782	Wire branch guard
210878	Dust cover with black top
	<b>Model 901 and 951</b>
210050	Kit, aluminum flush magnetic mount
210830	Polycarbonate 1" pipe/flush mount bottom
210831	Kit, polycarbonate flush magnetic mount
210837	1" to 1/2" pipe adapter for 210830 and 210982
210838	1" to 3/4" pipe adapter for 210830 and 210982
210846	Aluminum flush enclosed bottom
210923	Aluminum raised enclosed bottom
210928	Magnetic mount kit for aluminum/polycarbonate mount bottoms
210982	Aluminum 1" pipe/flush mount bottom

### Note

- See page 23 for specification drawings.

Model	Operating Voltage	Amp Draw	Joules	Watts	FPM	Approvals	Base Material	Dome Colors	Dimensions (D x H)	Ship Weight (lbs)	Warranty (years)
<b>Model 901</b>	12/48	2.1A @ 12V to 0.55A @ 48V	18/9	21.3	75	Class 1	Aluminum	Amber, Blue, Clear, and Red	6.51" x 5.69"	2.3	5
<b>Model 951</b>	12/48	2.1A @ 12V to 0.55A @ 48V	18/9	21.3	75	Class 1, Title 13	Aluminum	Amber, Blue, Clear, and Red	6.51" x 7.62"	2.7	5



210830



210831



210838 (left), 210837 (right)

# Model 851

- Open-style aluminum base strobe beacon
- Automatic adjustment to function at any voltage from 12-48VDC
- High-profile strobe beacon
- SAE J845 Class 1 approved (SAE J1318 Class 1, 2009)
- Five-year product warranty



CLASS 1

Model	Description
<b>Model 851 Plus models</b>	
<b>12J, 16W, 12-48VDC, double flash</b>	
420400-02	Open style bottom, Amber; -03(Blue); -04(Red); -05(Clear)
211789-02	Magnetic mount, Amber; -05(Clear)
420406-02	UTILITY LIGHT, blackout lens, clear dust cover, branch guard, and polycarbonate mounting base
420412-02	Aluminum 1" pipe/flush mount bottom, Amber; -05(Clear)
<b>10J, 13.3W, 115VDC, single flash</b>	
412047-02	Enclosed bottom, A/C line cord, Amber; -03(Blue); -04(Red); -05(Clear)
412048-02	Enclosed bottom, pipe flange, Amber; -03(Blue); -04 (Red); -05(Clear)
<b>Model 851-RR</b>	
<b>10J, 13.3W, 72VDC, single flash</b>	
412046-02	Enclosed bottom, spike filter, Amber; -03(Blue); -04(Red); -05(Clear)

### Accessories and Kits

210782	Wire branch guard
210939	"L" mounting bracket
210830	Polycarbonate 1" pipe/flush mount bottom
210982	Aluminum 1" pipe/flush mount bottom
210831	Kit, polycarbonate flush magnetic mount
210050	Kit, aluminum flush magnetic mount
210837	1" to 1/2" pipe adapter for 210830 and 210982
210838	1" to 3/4" pipe adapter for 210830 and 210982
210846	Aluminum flush enclosed bottom
210923	Aluminum raised enclosed bottom
210928	Magnetic mount kit for aluminum/polycarbonate mount bottoms
210878	Dust cover with black top
200776-95	Polycarbonate dust cover without black cover

### Common Replacement Parts

211400-95	Flash tube
205003-95	Gasket, base
205004-95	Gasket, dome
208551-95	Base
438694-95	Kit, mounting
200771-95	Dome, Blue
200772-95	Dome, Clear
200773-95	Dome, Red
200775-95	Dome, Amber
Z2005265B	Power supply, double flash
211024-95	Power supply, 72VDC
211007-95	Power supply, 115VAC

### Note

- See page 23 for specification drawings.

Model	Operating Voltage	Amp Draw	Joules	Watts	FPM	Approvals	Base Material	Dome Colors	Dimensions (D x H)	Ship Weight (lbs)	Warranty (years)
Model 851	12/48	1.65A @ 12V	12	16	80	Class 2	Aluminum	Amber, Blue, Clear, and Red	6.6" x 7.74"	2.2	5



210782



210830



210831

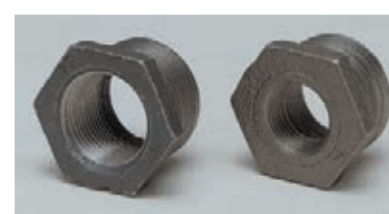

210838 (left), 210837 (right)

# Model 651

- Open-style aluminum base strobe beacon
- Automatic adjustment to function at any voltage from 12-48VDC
- Low-profile strobe beacon
- SAE J845 Class 2 approved (SAE J1318 Class 2, 2009)
- Five-year product warranty

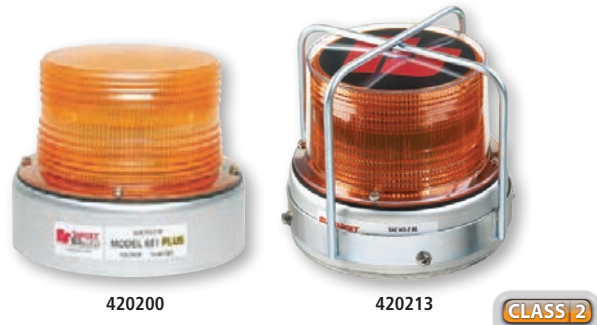

Model	Description
<b>Model 651 Plus models</b>	
<b>12J, 16W, 12-48VDC, double flash</b>	
420200-02	Open style bottom, Amber; -03(Blue); -04(Red); -05(Clear)
420205-02	Black top dome, open-style bottom, Amber: -03(Blue); -04(Red)
420208-02	UTILITY LIGHT, blackout lens, Clear dust cover, and polycarbonate mounting base, Amber
420212-02	Aluminum 1" pipe/flush mount bottom, Amber; -05(Clear)
420213-02	UTILITY LIGHT, blackout lens, Clear dust cover, branch guard, and aluminum 1" pipe/flush mount bottom, Amber
<b>10J, 13.3W, 115VAC, single flash</b>	
412027-02	Enclosed bottom/AC line cord, Amber; -03(Blue); -04(Red); -05(Clear)
412028-02	Enclosed bottom/pipe flange, Amber; -03(Blue); -04(Red); -05(Clear)
<b>Model 651 AUL models</b>	
<b>11J, 14.7W, single flash, enclosed bottom</b>	
412010-02	12VDC, Amber; -03(Blue); -05(Clear)
412013-02	24VDC, spike filter, Amber; -03(Blue); -04(Red)

## Accessories and Kits

210781	Wire branch guard (used on 651 Plus and 651 AUL models)
210939	"L" mounting bracket
210830	Polycarbonate 1" pipe/flush mount bottom
210982	Aluminum 1" pipe/flush mount bottom
210831	Kit, polycarbonate flush magnetic mount
210050	Kit, aluminum flush magnetic mount
210837	1" to 1/2" pipe adapter for 210830 and 210982
210838	1" to 3/4" pipe adapter for 210830 and 210982
210846	Aluminum flush enclosed bottom
210923	Aluminum raised enclosed bottom
210928	Magnetic mount kit for aluminum/polycarbonate mount bottoms
210877	Dust cover with black top
200765-95	Polycarbonate dust cover without black cover

## Common Replacement Parts

211200-95	Flash tube
205003-95	Gasket, base
205004-95	Gasket, dome
208551-95	Base
438694-95	Kit, mounting
200766-95	Dome, Blue
200767-95	Dome, Amber
200768-95	Dome, Clear
200769-95	Dome, Red
<b>Model 651 Plus models only</b>	
Z2005265B	Power supply, double flash
430344-95	Power supply, quad flash
211024-95	Power supply, 72VDC
211007-95	Power supply, 115VAC
<b>Model 651 AUL models only</b>	
211090-95	Power supply, 12VDC

## Note

- See page 23 for specification drawings.

Model	Operating Voltage	Amp Draw	Joules	Watts	FPM	Approvals	Base Material	Dome Colors	Dimensions (D x H)	Ship Weight (lbs)	Warranty (years)
<b>Model 651</b>	12/48, 72	1.65A @ 12V to 0.41 @ 48V	12/10	12/10	80	Class 2	Aluminum	Amber, Blue, Clear, and Red	6.51" x 5.65"	2.0	5

**Model 901 and Model 651**

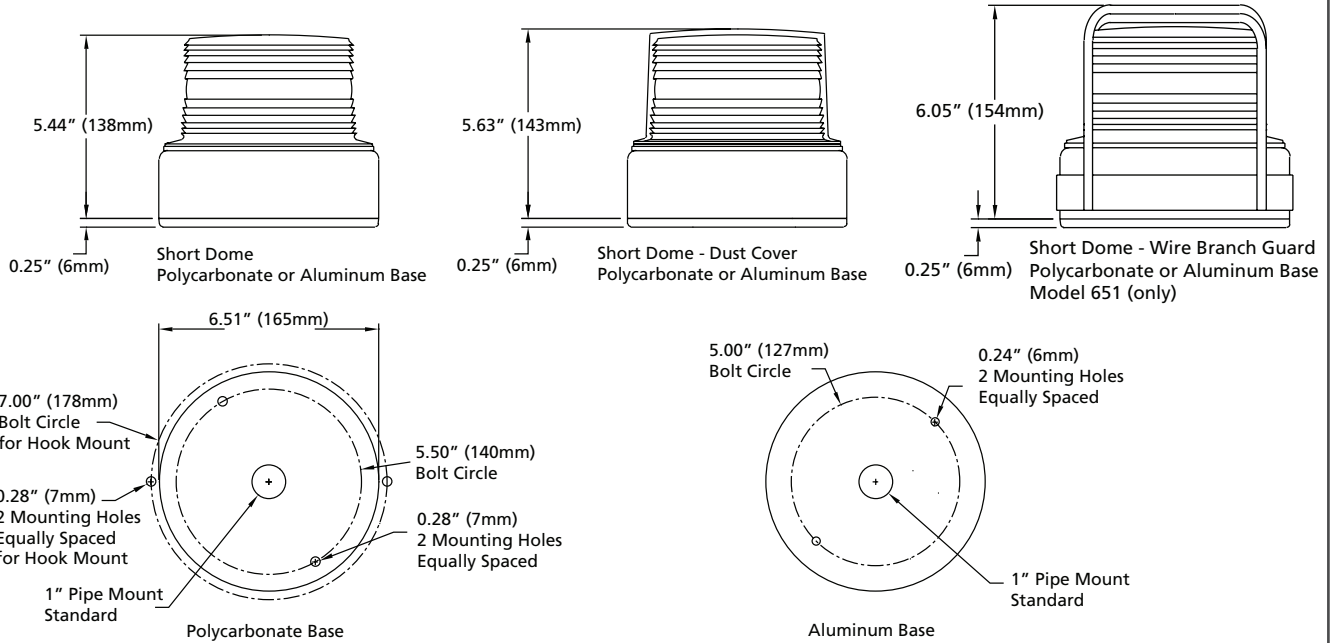

**Model 951 and Model 851**

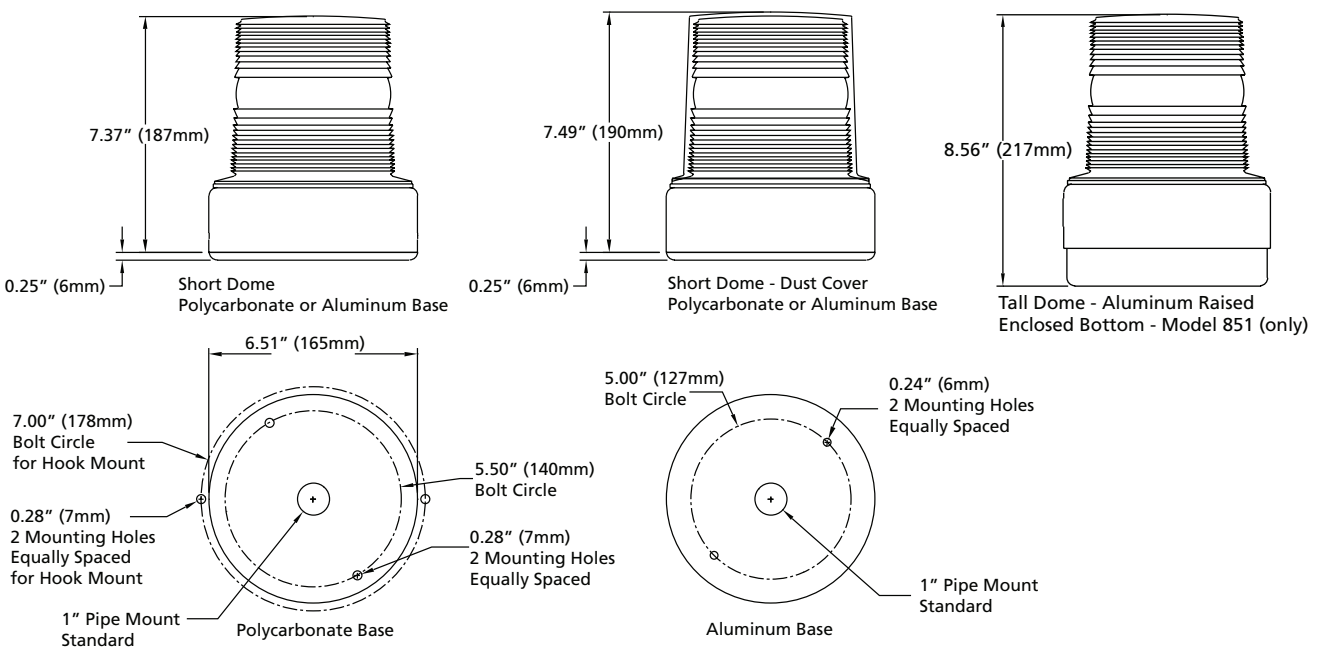

# Pulsator® 551 Plus

- High-profile, polycarbonate base strobe beacon
- Easily replaceable helical strobe tube
- Automatic adjustment to function at any voltage from 12-48VDC
- SAE J845 Class 2 approved (SAE J1318 Class 2, 2009)
- Three-year product warranty



CLASS 2

Model	Description
211694-02	<b>8J, 16W, 12-24VDC, 120FPM, single flash</b> Permanent mount, Amber; -03(Blue); -04(Red); -05(Clear)
211695-02	Magnetic mount, Amber
211681-02	<b>10J, 13.3W, 12-48VDC, double flash</b> Permanent mount, Amber; -03(Blue); -04(Red); -05(Clear)
211684-02	Magnetic mount, Amber; -04(Red); -05(Clear)
211820-02	HEAVY DUTY, permanent mount, Amber; -03(Blue); -04(Red); -05(Clear)
211925-02	<b>5J, 5.8W, 115VAC</b> Permanent mount, double flash, Amber; -03(Blue); -04(Red); -05(Clear)

### Accessories and Kits

200069-95	Bottom plate
210890	Kit, magnetic mount
210891	Kit, self-adhesive mounting
210893	1/2" pipe mount
210894	3/4" pipe mount
210895	1" pipe mount
210377	Wiring kit, 30-ft, strobes

### Common Replacement Parts

2005082B-95	Power supply, 10-Joules, quad flash
2005082B-12-95	Power supply, 10-Joules, double flash
2005035A-95	Power supply, 115VAC, double flash
208666-95	Dome, Blue
208667-95	Dome, Amber
208668-95	Dome, Red
208669-95	Dome, Clear
439290-95	Flash tube

### Note

- See page 25 for specification drawings.

Model	Operating Voltage	Amp Draw	Joules	Watts	FPM	Approvals	Base Material	Dome Colors	Dimensions (D x H)	Ship Weight (lbs)	Warranty (years)
Pulsator 551 Plus	12/48	1.2A @ 12V to 0.3A @ 48V (10J)	10/8	13.3/12.5	80/75	Class 2	Polycarbonate	Amber, Blue, Clear, and Red	6.5" x 6.0"	1.5 1.9 (Heavy Duty)	3



210890



210891



210377



210893



210894



210895



# Pulsator® 451 Plus

- Low-profile, polycarbonate base strobe beacon
- Easily replaceable helical strobe tube
- Automatic adjustment to function at any voltage from 12-48VDC
- SAE J845 Class 2 approved (SAE J1318 Class 2, 2009)
- Three-year product warranty



**CLASS 2**

Model	Description
	<b>8J, 10.7W, 12-48VDC, double flash</b>
211680-02	Permanent mount, Amber; -03(Blue); -04(Red); -05(Clear)
211682-02	Magnetic mount, Amber; -03(Blue); -04(Red); -05(Clear)
211823-02	HEAVY DUTY, permanent mount, Amber; -03(Blue); -04(Red); -05(Clear)

### Accessories and Kits

200069-95	Bottom plate
210890	Kit, magnetic mount
210893	1/2" pipe mount
210894	3/4" pipe mount
210895	1" pipe mount
210377	Wiring kit, 30-ft, strobes
210387	Wiring kit, one strobe
210376	Wiring kit, two strobes

### Common Replacement Parts

2005082B-23-95	Power supply, double flash
208566-95	Dome, Blue
208567-95	Dome, Amber
208568-95	Dome, Red
208569-95	Dome, Clear
439411-95	Flash tube

Model	Operating Voltage	Amp Draw	Joules	Watts	FPM	Approvals	Base Material	Dome Colors	Dimensions (D x H)	Ship Weight (lbs)	Warranty (years)
Pulsator 451 Plus	12/48	0.9A @ 12V to 0.25 @48V	8	10.7/10	80/75	Class 2	Polycarbonate	Amber, Blue, Clear, and Red	6.5" x 4.0"	1.3 1.6 (Heavy Duty)	3

### Model 551 Plus and Model 451 Plus

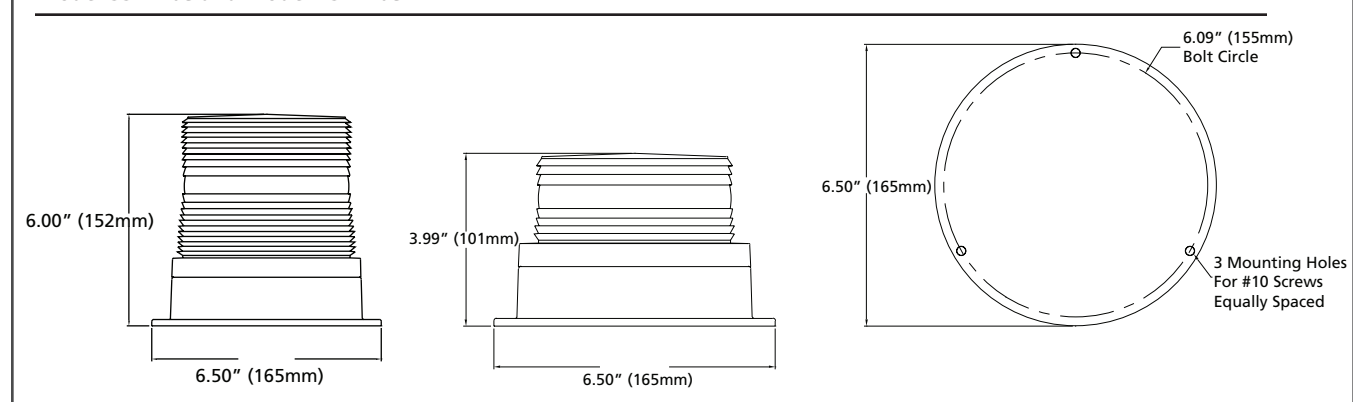

210377



210387



210376

# Model 401

- Low-profile strobe beacon
- Automatic adjustment to function at any voltage from 12-48 VDC
- Features rubber base that resists corrosion and absorbs harsh shock
- SAE J845 Class 2 approved (SAE J1318 Class 2, 2009)
- Three-year product warranty



**CLASS 2**

Model	Description
220300-02	<b>Double Flash, permanent mount</b> 5J, 5.4W, 12-48VDC, 65 FPM, Amber; -03(Blue); -04(Red)
220301-02	<b>Single Flash, permanent mount</b> 5J, 5.4W, 12-48VDC, 65 FPM, Amber; -03(Blue); -04(Red)
220308-02	<b>Double Flash, magnetic mount</b> 5J, 5.4W, 12-48VDC, 65 FPM, Amber; -03(Blue); -04(Red)
220309-02	<b>Single Flash, magnetic mount</b> 5J, 5.4W, 12-48VDC, 65 FPM, Amber; -03(Blue); -04(Red)

### Common Replacement Parts

8107230A-95	Flash Tube, Double Flash
2005191A-95	Power Supply, 12-48V, Double Flash
Z8263073-05	Dome, Amber; -01(Blue); -02(Red)

Model	Operating Voltage	Amp Draw	Joules	Watts	FPM	Approvals	Base Material	Dome Colors	Dimensions (D x H)	Ship Weight (lbs)	Warranty (years)
<b>Model 401</b>	12/48	0.65A @ 12V to 0.17A @ 48V	5	5.4	65	Class 2	Rubber	Amber, Blue, and Red	5.72" x 5.0"	1.3 1.9 (Heavy Duty)	3

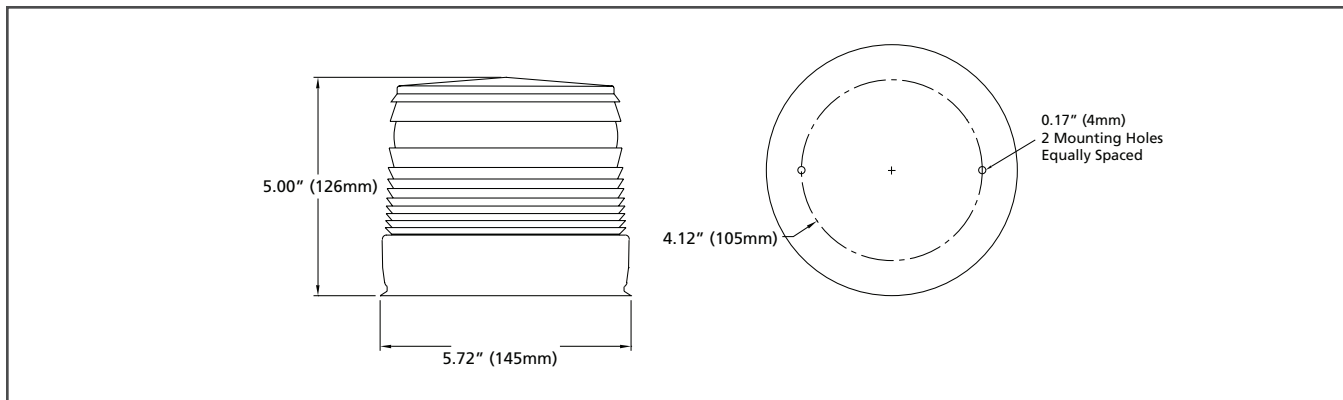

# Firebolt®

- Automatic adjustment to function at multi-voltages
- Polycarbonate base available in permanent and magnetic models
- Three-year product warranty



Model	Description
	<b>2J, 2W, 12-72VDC, single flash</b>
220100-02	Permanent mount, Amber; -03(Blue); -04(Red); -05(Clear)
210873-02	Magnetic mount, Amber; -03(Blue); -04(Red); -05(Clear)
	<b>2J, 2W, 115VAC, single flash</b>
212356-02	Permanent mount, Amber; -03(Blue); -04(Red); -05(Clear)
	<b>5J, 5.4W, 12-48VDC, double flash</b>
220105-02	Permanent mount, Amber; -03(Blue); -04(Red); -05(Clear)
220110-02	Magnetic mount, Amber
	<b>Firebolt Plus</b>
	<b>2J, 2W, 12-72VDC, single flash, replaceable strobe tube</b>
220200-02	Permanent mount, Amber; -03(Blue); -04(Red); -05(Clear)
220208-02	Magnetic mount, Amber; -03(Blue); -04(Red); -05(Clear)

### Accessories and Kits

210376	Kit, wiring, (2) strobes
210377	Kit, wiring, 30-ft, strobes
210539	"L" mounting bracket
210728	Kit, magnetic mount with cigarette plug
210850	Adapter, pipe mount, 3/4"
210881	Adapter, pipe mount, 1/2"
210862	Kit, mounting self-adhesive
211676	Dome guard assembly, Chrome

### Common Replacement Parts

211300-95	Flash tube, FireBolt Plus
211356-95	Power supply and flash tube, 115VAC, FireBolt
211360-95	Power supply and flash tube, 2-Joules, FireBolt
211550-95	Power supply, FireBolt Plus
2005143B-95	Power supply and flash tube, 5-Joules, 115VAC, FireBolt
205580-95	Dome, Amber
205581-95	Dome, Red
205582-95	Dome, Clear
205584-95	Dome, Blue
200523-95	Gasket, dome
208505-95	Base

Model	Operating Voltage	Amp Draw	Joules	Watts	FPM	Approvals	Base Material	Dome Colors	Dimensions (D x H)	Ship Weight (lbs)	Warranty (years)
Firebolt	12/72 @ 2J 12/48 @ 5J	0.24 @ 12V to 0.04 @ 72V (2J); 0.65A @ 12V to 0.17 @ 48V (5J)	2/5	2/5.4	60/65	Class 3	Polycarbonate	Amber, Blue, Clear, and Red	5.10" x 3.61"	0.7	3
Firebolt Plus	12/72 @ 2J 12/48 @ 5J	0.24A @ 12V to 0.04A @ 24V	2	16	60/65	Class 3	Polycarbonate	Amber, Blue, Clear, and Red	5.10" x 3.61"	0.7	3

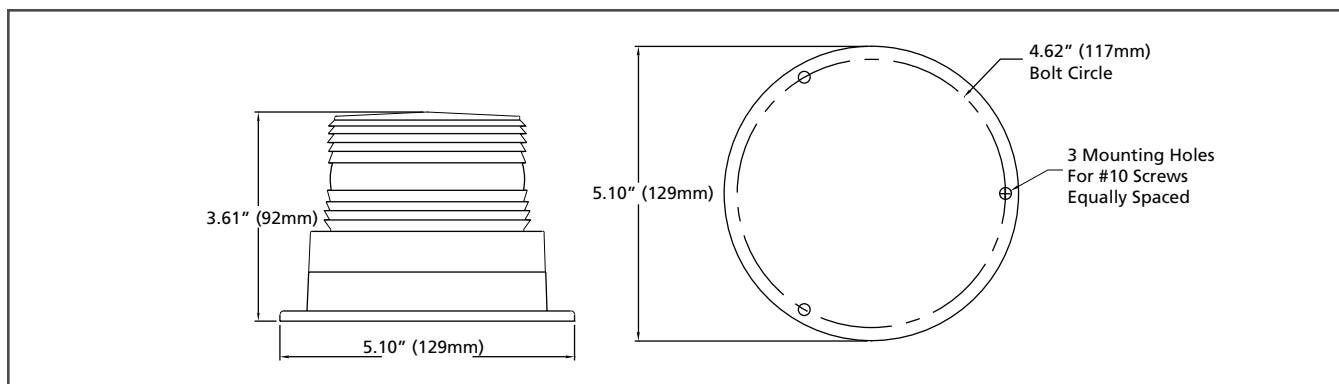

# Renegade®

- Easily replaceable strobe tube
- Vibration and moisture resistant
- Automatic adjustment to function at any voltage from 12-48VDC
- SAE J845 Class 3 approved (SAE J1318 Class 3, 2009)
- Three-year product warranty



**CLASS 3**

Model	Description
462121-02	<b>2.2J, 2.6W, 12-48VDC, double flash</b> Permanent 1/2" pipe mount, Amber; -03(Blue); -04(Red); -05(Clear)
462141-02	Magnetic mount with cigarette plug, Amber; -03(Blue); -04(Red); -05(Clear)

Kit	Description
462400	Kit, magnetic mount

Common Replacement Parts	
462500-02	Dome, Amber; -03(Blue); -04(Red); -05(Clear)
462510	Flash tube assembly
462520	Trim ring
462530	Gasket, dome
462540	Gasket, mounting

Model	Operating Voltage	Amp Draw	Joules	Watts	FPM	Approvals	Base Material	Dome Colors	Dimensions (D x H)	Ship Weight (lbs)	Warranty (years)
Renegade	12/48	0.3A @ 12V	2.2	2.6	75	Class 3	Polycarbonate	Amber, Blue, Clear, and Red	2.86" x 4.27" Pipe Mount 4.0" x 4.27" Permanent Mount	0.9	3

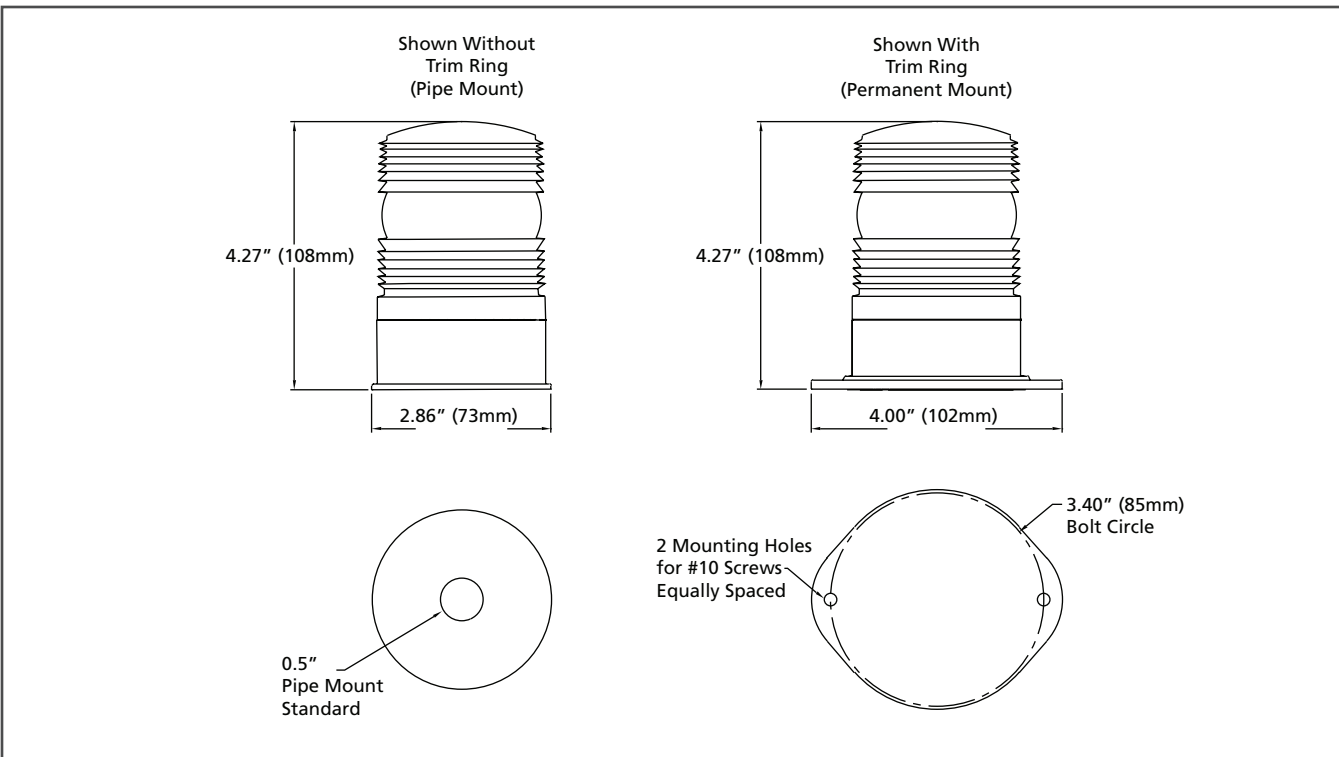

# Sentry®

- Rugged, polycarbonate housing features twist-off dome for easy maintenance
- Compact size allows for a variety of mounting options
- Large parabolic reflector and 55-watt halogen bulb produce an attention-getting 80,000 candelas per flash
- Domes are available in Amber, Blue, Clear, Green, and Red
- SAE J845 Class 1 approved
- Five-year product warranty



CLASS 1

Model	Description
<b>12VDC, 95 FPM</b>	
448112-02	Permanent mount, Amber; -03(Blue); -04(Red); -05(Clear)
448122-02	Pipe mount, Amber; -03(Blue); -04(Red); -05(Clear)
448142-02	Magnetic mount, Amber; -03(Blue); -04(Red); -05(Clear)
<b>24VDC, 95 FPM</b>	
448114-02	Permanent mount, Amber; -04(Red)
448144-02	Magnetic mount, Amber; -03(Blue); -04(Red); -05(Clear)
<b>12VDC, 175 FPM</b>	
449112-02	Permanent mount, Amber; -03(Blue); -04(Red); -05(Clear)
449122-02	Pipe mount, Amber; -03(Blue); -04(Red)
449142-02	Magnetic mount, Amber; -03(Blue); -04(Red); -05(Clear)

### Accessories and Kits

448320	Branch guard pipe mount adapter
448330	Branch guard
448410	Kit, magnetic mount
448310	Kit, vibration mount

### Common Replacement Parts

Z8440A265A-02	Bulb, 12VDC, 55W, halogen, long life
439231-95	Bulb, 24VDC, 70W
447532	Motor, 12VDC, 95 FPM
447539	Motor, 12VDC, 175 FPM
447534	Motor, 24VDC, 95 FPM
448572	Rotator, 12VDC, 95 FPM
448522	Rotator, 12VDC, 175 FPM
448514	Rotator, 24VDC, 95 FPM
448524	Rotator, 24VDC, 175 FPM
448500-02	Dome, Amber; -03(Blue); -04(Red); -05(Clear)

Model	Operating Voltage	Amp Draw	Lamp	Candelas	FPM	Approvals	Base Material	Dome Colors	Dimensions (D x H)	Ship Weight (lbs)	Warranty (years)
Sentry	12/24	4.3 @ 12V; 2.1 @ 24V	55/70	80,000	95/175	Class 1, Title 13	Polycarbonate	Amber, Blue, Red, and Clear	6.33" x 6.48"	2.0	5

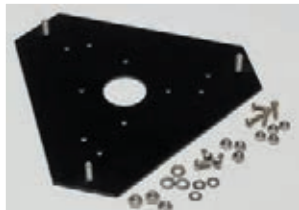
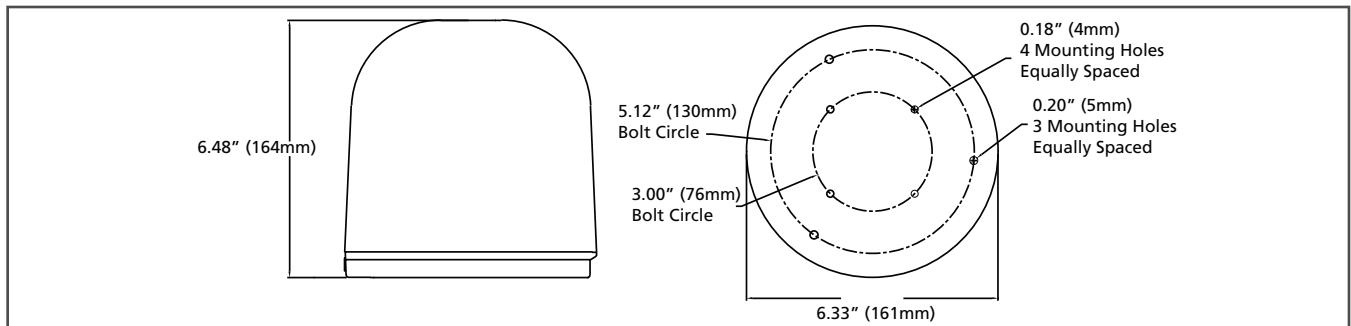

448320



448330



448410



448310



# Model 100

- Years of reliable service have made the Model 100 an industry standard
- Powerful 80,000-candelas halogen rotator that draws only 4.3 amps
- Rotator "floats" on a neoprene washer to absorb vibration
- SAE J845 Class 1 approved



CLASS 1

Model	Description
442112-02	<b>Model 100, 12VDC, 175 FPM</b> Permanent mount, Amber; -03(Blue); -04(Red); -05(Clear)
442114-02	<b>Model 100, 24VDC, 175 FPM</b> Permanent mount, Amber; -03(Blue); -04(Red); -05(Clear)
443113-02	<b>Model 100, 12VDC, 120 FPM</b> Permanent mount, Amber; -03(Blue); -04(Red); -05(Clear)
443112-02	<b>Model 100, 12VDC, 95 FPM</b> Permanent mount, Amber; -03(Blue); -04(Red); -05(Clear)
443212-02	Magnetic mount, Amber
443312-02	Magnetic mount, replacement bulb, Amber
443612-02	"Model 101", permanent mount, mounting pad, Amber
443712-02	Permanent mount, long-life bulb, mounting pad, Amber
443114-02	<b>Model 100, 24VDC, 95 FPM</b> Permanent mount, Amber; -03(Blue); -04(Red); -05(Clear)
443314-02	Permanent mount, replacement bulb, Amber

### Accessories and Kits

210880-01	Self-leveling bracket
447302	Kit, vibration mount
447303	Branch guard

### Common Replacement Parts

Z8440A265A-02	Bulb, 12VDC, 55W, halogen, long life
439231-95	Bulb, 24VDC, 70W
447532	Motor, 12VDC, 95 FPM
447542	Motor, 12VDC, 120 FPM
447539	Motor, 12VDC, 175 FPM
447534	Motor, 24VDC, 95 FPM
447544	Motor, 24VDC, 175 FPM
442512	Rotator, 12VDC, 95 FPM
442522	Rotator, 12VDC, 175 FPM
442524	Rotator, 24VDC, 175 FPM
Z8422C002-01	Dome, Red; -04(Amber); -05(Clear); -09(Blue)

Model	Operating Voltage	Amp Draw	Lamp	Candelas	FPM	Approvals	Base Material	Dome Colors	Dimensions (D x H)	Ship Weight (lbs)	Warranty (years)
Model 100	12/24	4.3 @ 12V; 2.1 @ 24V	55/70	80,000	95/120/195	Class 1, Title 13	Polycarbonate	Amber, Blue, Red, and Clear	8.42" x 7.31"	4.0	5

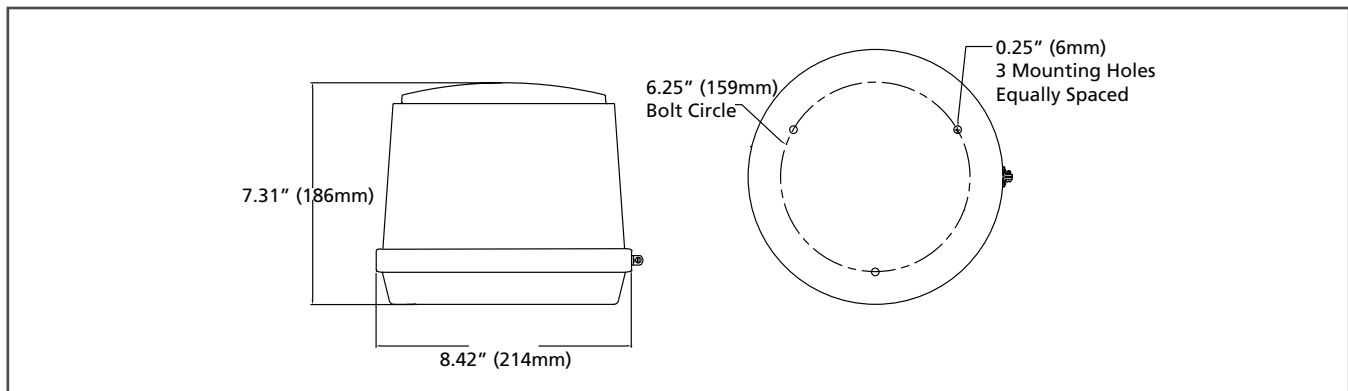

**LED Beacons**

Model	Operating Voltage	Amp Draw	FPM	Flash Patterns	Approvals	Base Material	Dome Colors	Dimensions (D x H)	Ship Weight (lbs)	Warranty (years)
SLR Beacon	12/24	1.8A @ 12.8 V	75/90/120	-	Class 1 & 2	Aluminum/Polycarbonate	Amber, Clear and Red	7.09" x 5.75"	2.75	5
UltraStar LED	12/24	1.2A @ 12.8 V	Various	12	Class 1	Aluminum	Amber, Blue, Clear, Green and Red	6.5" x 5.25"	2.75 (perm.) 3.5 (mag.)	5
Pulsator LED	12/24	0.80A @ 12.8 V 0.40A @ 25.6 V	Various	10	Class 1 & 2	Polycarbonate	Amber, Blue, Clear, Green and Red	6.5" x 6.0"	1.9	5
651 LED	12/24	1A @ 12.8V	Various	4	Class 2	Aluminum	Amber	6.51" x 5.4" 6.51" x 6.05" (Wire Branch Guard)	2	5
AL2	12/24	1A @ 12.8 V	Various	4	Class 2	Aluminum or Chrome-plated Aluminum	Amber	9.0" x 8.6"	3.8	5

**Strobe Beacons**

Model	Operating Voltage	Amp Draw	Joules	Watts	FPM	Approvals	Base Material	Dome Colors	Dimensions (D x H)	Ship Weight (lbs)	Warranty (years)
UltraStar US 5	12/24	1.8A @ 12V to 0.9A @ 24V	13/14	18.4/19	85/80	Class 1 & 2	Aluminum	Amber, Blue, Clear, and Red	6.5" x 6.74" (Tall) 6.5" x 5.25" (Short)	4.0	5
UltraStar US 6	12/24	2.0A @ 12.8V to 1.2A @ 25.6V (high) 1.6A @ 12.8V to 0.8A @ 25.6V (low)	17/12	17/12	75	Class 1	Aluminum	Amber, Blue, Clear, and Red	6.5" x 6.7" (Perm.) 6.5" x 6.9" (Mag.)	4.25 (Perm.) 4.95 (Mag.)	5
UltraStar US 7	12/24	2.5A @ 12V to 1.2A @ 24V	21/13 Hi-Lo	21.3/15	75	Class 1	Aluminum	Amber, Blue, Clear, and Red	6.5" x 6.74" (Tall)	4.0	5
Model 901	12/48	2.1A @ 12V to 0.55A @ 48V	18/9	21.3	75	Class 1	Aluminum	Amber, Blue, Clear, and Red	6.51" x 5.69"	2.3	5
Model 951	12/48	2.1A @ 12V to 0.55A @ 48V	18/9	21.3	75	Class 1, Title 13	Aluminum	Amber, Blue, Clear, and Red	6.51" x 7.62"	2.7	5
Model 851	12/48	1.65A @ 12V	12	16	80	Class 2	Aluminum	Amber, Blue, Clear, and Red	6.6" x 7.74"	2.2	5
Model 651	12/48, 72	1.65A @ 12V to 0.41 @ 48V	12/10	12/10	80	Class 2	Aluminum	Amber, Blue, Clear, and Red	6.51" x 5.65"	2.0	5
Pulsator 551 Plus	12/48	1.2A @ 12V to 0.3A @ 48V (10J)	10/8	13.3/12.5	80/75	Class 2	Polycarbonate	Amber, Blue, Clear, and Red	6.5" x 6.0"	1.5 1.9 (Heavy Duty)	3
Pulsator 451 Plus	12/48	0.9A @ 12V to 0.25 @ 48V	8	10.7/10	80/75	Class 2	Polycarbonate	Amber, Blue, Clear, and Red	6.5" x 4.0"	1.3 1.6 (Heavy Duty)	3
Model 401	12/48	0.65A @ 12V to 0.17A @ 48V	5	5.4	65	Class 2	Rubber	Amber, Blue, and Red	5.72" x 5.0"	1.3 1.9 (Heavy Duty)	3
Firebolt	12/72 @ 2J 12/48 @ 5J	0.24 @ 12V to 0.04 @ 72V (2J); 0.65A @ 12V to 0.17 @ 48V (5J)	2/5	2/5.4	60/65	Class 3	Polycarbonate	Amber, Blue, Clear, and Red	5.1" x 3.61"	0.7	3
Firebolt Plus	12/72 @ 2J 12/48 @ 5J	0.24A @ 12V to 0.04A @ 24V	2	16	60/65	Class 3	Polycarbonate	Amber, Blue, Clear, and Red	5.1" x 3.61"	0.7	3
Renegade	12/48	0.3A @ 12V	2.2	2.6	75	Class 3	Polycarbonate	Amber, Blue, Clear, and Red	2.86" x 4.27" Pipe Mount 4.0" x 4.27" Permanent Mount	0.9	3
AS2	12/24	1.65A @ 12V	12	16	80	Class 2	Polycarbonate	Amber	9.0" x 8.6"	3.8	5

**Halogen Beacons**

Model	Operating Voltage	Amp Draw	Lamp	Candelas	FPM	Approvals	Base Material	Dome Colors	Dimensions (D x H)	Ship Weight (lbs)	Warranty (years)
Sentry	12/24	4.3 @ 12V; 2.1 @ 24V	55/70	80,000	95/175	Class 1, Title 13	Polycarbonate	Amber, Blue, Red, and Clear	6.33" x 6.48"	2.0	5
Model 100	12/24	4.3 @ 12V; 2.1 @ 24V	55/70	80,000	95/120/195	Class 1, Title 13	Polycarbonate	Amber, Blue, Red, and Clear	8.42" x 7.31"	4.0	5



# VPX SignalMaster™



- High output Solaris® LED reflector technology
- Fully encapsulated waterproof LED modules
- Wide angle lens for better off-axis warning
- Each LED module contains (8) high-powered LEDs
- Five-year LED warranty

CLASS 1



Model	Description
320842	20", (4) LED modules, 30-ft cable, Amber LEDs with Amber lens
320862	31", (6) LED modules, 30-ft cable, Amber LEDs with Amber lens
320866	31", (6) LED modules, 60-ft cable, Amber LEDs with Amber lens
320882	42", (8) LED modules, 30-ft cable, Amber LEDs with Amber lens
320886	42", (8) LED modules, 60-ft cable, Amber LEDs with Amber lens
320892	51", (8) LED modules, 30-ft cable, Amber LEDs with Amber lens
320893	51", (8) LED modules, 50-ft cable, Amber LEDs with Amber lens

### Common Replacement Parts

Z8613194A-01	Viper EXT, Amber LEDs with Amber lens
Z8613194A-02	Viper EXT, Blue LEDs with Blue lens
Z8613194A-03	Viper EXT, Red LEDs with Red lens
Z8613194A-04	Viper EXT, Amber LEDs with Clear lens
Z8613194A-05	Viper EXT, Blue LEDs with Clear lens
Z8613194A-06	Viper EXT, Red LEDs with Clear lens

### Note

- See page 34 for SignalMaster mounting brackets.
- See page 34 for SignalMaster controllers.

# LED SignalMaster™



- Extremely low amp draw reduces strain on electrical systems
- Internal or external mounting
- Four built-in housing channels for flexible mounting
- Five-year LED warranty

CLASS 2

Model	Description
	<b>SignalMaster T-1-3/4 LED Units</b>
320742	20", (4) LED modules, 30-ft cable, Amber LEDs with Amber lens
320752	31", (6) LED modules, 15-ft cable, Amber LEDs with Amber lens
320762	31", (6) LED modules, 30-ft cable, Amber LEDs with Amber lens
320766	31", (6) LED modules, 60-ft cable, Amber LEDs with Amber lens
320772	42", (8) LED modules, 15-ft cable, Amber LEDs with Amber lens
320782	42", (8) LED modules, 30-ft cable, Amber LEDs with Amber lens
320786	42", (8) LED modules, 60-ft cable, Amber LEDs with Amber lens
320792	51", (8) LED modules, 30-ft cable, Amber LEDs with Amber lens
320793	51", (8) LED modules, 50-ft cable, Amber LEDs with Amber lens
321722	84", DOT strip, 35-ft cable
	<b>SignalMaster II Light Models (includes control)</b>
321702	42", control, S/T/T override, 15-ft cable
321712	51", control, S/T/T override, 35-ft cable
	<b>Complete System Models</b>
330312	(1) 320782 light and (1) 331105 controller

### Common Replacement Parts

Z8573229A-02	LED Module Assy, SignalMaster T1-3/4 LEDs, Clear Lens, Amber LEDs
--------------	---

### Note

- See page 34 for SignalMaster mounting brackets.
- See page 34 for SignalMaster controllers.



## SignalMaster™ Plus

- Individually sealed LED modules with wide-angle lens
- Sturdy aluminum extrusion
- Internal or external mounting applications
- Each LED module contains (3) high-powered LEDs
- SAE J595 Class 2 approved
- Three-year LED warranty



SMLED-PLS-8

CLASS 2

Model	Description
SMLED-PLS-6	28", (6) LED modules, 30-ft cable, Clear Lens with Amber LEDs
SMLED-PLS-8	37", (8) LED modules, 50-ft cable, Clear Lens with Amber LEDs

### Notes

- See page 34 for SignalMaster mounting brackets
- See page 34 for SignalMaster controllers

## SignalMaster™

- Housing blocks sunlight to increase warning effectiveness
- Unique lens spreads light horizontally for increased warning coverage
- Easy to maintain and service
- Three-year product warranty



Model	Description
<b>Halogen SignalMaster</b>	
320142	20", (4) lamp, 30-ft cable, Amber lens
320162	31", (6) lamp, 15-ft cable, Amber lens
320612	31", (6) lamp, 30-ft cable, Amber lens
320172	42", (8) lamp, 15-ft cable, Amber lens
320182	42", (8) lamp, 30-ft cable, Amber lens
320192	42", (8) lamp, 50-ft cable, Amber lens
320602	84", DOT strip, 35-ft cable, Amber lens
<b>Complete System Models</b>	
323142	(2) 320142 lights; (1) 330104 controller and (2) 320310 mounts
330302	(1) 320612 light and (1) 331105 controller
322112	(1) 320182 light and (1) 331105 controller
322122	(1) 320192 light and (1) 331105 controller
322612	(1) 51" light with (1) 30-ft cable and (1) 331105 controller
322132	(1) 320182 light, (1) 331105 controller and (1) 320320 mount
<b>SignalMaster II light models, includes integrated control</b>	
321102	42", (8) lamp, control, S/T/T override, 15-ft cable
321112	51", (8) lamp, control, S/T/T override, 35-ft cable

### Accessories and Kits

320400	Kit, 50-ft cable
320401	LED upgrade, single LED module
320404	LED upgrade, 4-LED module
320406	LED upgrade, 6-LED module
320408	LED upgrade, 8-LED module

### Common Replacement Parts

322502	Bulb, SignalMaster, 27W
322512-02	Lens, SignalMaster, Amber
Z140325A-13	15-position female connector for full-featured controller
Z8573157B-01	SignalMaster II control
Z8573180A	Reflector and terminal assembly, SignalMaster
Z8573001B	Lens, SignalMaster, Clear; -01(Red); -02(Amber); -03(Blue); -04(Green);

### Notes

- See page 34 for SignalMaster mounting brackets.
- See page 34 for SignalMaster controllers.



## SignalMaster™ Controls

- Controls six or eight lamp directional lights
- Installer selectable flash patterns
- Tactile membrane keypad
- Turn signal override feature (331105)
- Three-year warranty



330104-SB



331105-SB

Model	Description
330104-SB	Six or eight-lamp, 12 or 24V (multiple installer-selectable flash patterns, fuse protected)
331105-SB	Heavy Duty six or eight-lamp, 12 or 24V (slide switch, multiple installer-selectable flash patterns, heavy duty ground, fuse protected, controls two halogen or LED SignalMasters simultaneously), turn signal override feature

### Common Replacement Part

Z140325A-13	15-position female connector for full-featured controller
-------------	---

## SignalMaster Mounting Brackets — for use with any SignalMaster model



320310 Kit, bracket, flush mount system



320330 Kit, bracket, system mount



320350 Kit, bracket, foot adaptor



320320 Kit, bracket, double "L" Mount



320340 Kit, bracket, universal vehicle mount

# Viper® EXT

- High-output Solaris® LED reflector technology
- Fully-encapsulated waterproof housing
- Wide angle lens for better off-axis warning
- Wide variety of synchronized patterns
- Models come standard with Black bezel
- LEDs offered in Amber, Blue, Green, Red, and White
- Dimensions: 5.7" (L) x 2.4" (H) x 1.5" (D) (with bezel)  
4.5" (L) x 1.9" (H) x 1.5" (D) (without bezel)
- Five-year LED warranty



CLASS 1



Model	Description
	<b>Clear off-axis lens</b>
VPX800-2	Amber, (8) high-powered LEDs
VPX800-3	Blue, (8) high-powered LEDs
VPX800-4	Red, (8) high-powered LEDs
VPX800-5	White, (8) high-powered LEDs
VPX800-6	Green, (8) high-powered LEDs
350172-25	Amber, (8) high-powered LEDs, 6" oval grommet mounting plate*
	<b>Colored off-axis lens</b>
VPX802-2	Amber, (8) high-powered LEDs
VPX802-3	Blue, (8) high-powered LEDs
VPX802-4	Red, (8) high-powered LEDs
VPX802-6	Green, (8) high-powered LEDs
350172-02	Amber, (8) high-powered LEDs, 6" oval grommet mounting plate*

\* For mounting in standard 6" oval cutouts

## Accessories and Kits

330507	Kit, 6" oval grommet mounting plate (sold individually, lighthead sold separately)
VPXM-1	Chrome bezel, all models

## Note

- See page 38 for mounting brackets.



## IPX6 IMPAXX®

- SpectraLux™ multicolor LED technology
- High-output Solaris® LED reflector technology
- Fully-encapsulated waterproof housing
- Available in 6-LED, 12-LED, or 18-LED models
- 23 Flash patterns available
- LEDs offered in Amber, Blue, Green, Red, and White
- Dimensions: 5.5" (L) x 2.0" (H) x 1.5" (D) (with bezel)  
4.1" (L) x 1.4" (H) x 1.4" (D) (without bezel)
- Five-year LED warranty



CLASS 1



SpectraLux

Model	Description
	<b>Single color, Clear off-axis lens, horizontal mount</b>
IPX600-A	(6) Amber LEDs
IPX600-B	(6) Blue LEDs
IPX600-G	(6) Green LEDs
IPX600-R	(6) Red LEDs
IPX600-W	(6) White LEDs
	<b>Single color, Colored off-axis lens, horizontal mount</b>
IPX602-A	(6) Amber LEDs
IPX602-B	(6) Blue LEDs
IPX602-R	(6) Red LEDs
	<b>Single color, Clear off-axis lens, vertical mount</b>
IPX603-A	(6) Amber LEDs
IPX603-B	(6) Blue LEDs
IPX603-G	(6) Green LEDs
IPX603-R	(6) Red LEDs
IPX603-W	(6) White LEDs
	<b>Colored lens, center focused lens</b>
IPX604-A	(6) Amber LEDs
IPX604-B	(6) Blue LEDs
IPX604-R	(6) Red LEDs
	<b>Dual color, Clear off-axis lens, horizontal mount</b>
IPX620-BA	(12) LEDs, Blue/Amber
IPX620-BR	(12) LEDs, Blue/Red
IPX620-BW	(12) LEDs, Blue/White
IPX620-RA	(12) LEDs, Red/Amber
IPX620-RW	(12) LEDs, Red/White
IPX620-WA	(12) LEDs, White/Amber

### Accessories

IPX6M-1	Chrome bezel, all models
IPX-GRL1	IPX3/IPX6/VPX8, pair of grille brackets with hardware, vertical mount orientation
IPX-GRL2	IPX3/IPX6/VPX8, pair of grille brackets with hardware, horizontal mount orientation
IPX-LPV1	IPX3/IPX6/VPX8, flat surface license plate mount, various vehicles without recessed plate mounting locations
IPX-LPVX1	IPX3/IPX6/VPX8, extended license plate bracket for vehicles with a recessed license plate mount location
IPX-LPH1	IPX3/IPX6/VPX8, generic high side license plate holder with horizontal mount tab on each side, fits most vehicles
IPX-TRNK1	IPX3/IPX6/VPX8, pair of inner trunk lid brackets with hardware
IPX-PB45H	IPX3/IPX6/VPX8, pair of 45-degree slanted push bumper mounts with hardware, horizontal light orientation, fits most push bumpers
IPX-PB45V	IPX3/IPX6/VPX8, pair of 45-degree slanted push bumper mounts with hardware, vertical light orientation, fits most push bumpers
IPX-PBL1	IPX3/IPX6/VPX8, pair, universal "L" bracket, horizontal orientation
330507	Viper EXT/3600 mounting bracket and grommet for standard oval cut-out "Series 60"

### Note

- See page 38 for mounting brackets.



## IPX3 IMPAXX®

- High-output Solaris® LED reflector technology
- Compact size allows for a variety of mounting locations
- Fully-encapsulated waterproof housing
- Wide angle lens for better off-axis warning
- Center focus lens also available
- Wide variety of synchronized patterns
- LEDs offered in Amber, Blue, Green, Red, and White
- Dimensions: 3.5" (L) x 1.4" (H) x 1.2" (D) (with bezel)  
2.9" (L) x 1.3" (H) x 1.2" (D) (without bezel)
- Five-year LED warranty



CLASS 1 CLASS 2 Amber lights only

Model	Description
	<b>Clear lens, advanced off-axis lens</b>
IPX300-2	Amber, (3) high-powered LEDs
IPX300-3	Blue, (3) high-powered LEDs
IPX300-4	Red, (3) high-powered LEDs
IPX300-5	White, (3) high-powered LEDs
IPX300-6	Green, (3) high-powered LEDs
	<b>Clear lens, center focused lens</b>
IPX310-2	Amber, (3) high-powered LEDs
IPX310-3	Blue, (3) high-powered LEDs
IPX310-4	Red, (3) high-powered LEDs
IPX310-5	White, (3) high-powered LEDs
IPX310-6	Green, (3) high-powered LEDs
	<b>Colored lens, advanced off-axis lens</b>
IPX302-2	Amber LEDs, (3) high-powered LEDs
IPX302-3	Blue LEDs, (3) high-powered LEDs
IPX302-4	Red LEDs, (3) high-powered LEDs
IPX302-6	Green LEDs, (3) high-powered LEDs
	<b>Colored lens, center focused lens</b>
IPX312-2	Amber LEDs, (3) high-powered LEDs
IPX312-3	Blue LEDs, (3) high-powered LEDs
IPX312-4	Red LEDs, (3) high-powered LEDs
IPX312-6	Green LEDs, (3) high-powered LEDs

**Accessory**

IPXM-1	Chrome bezel, all models
--------	--------------------------

**Note**

- See page 38 for mounting brackets.



## Grille Brackets



IPX-GRL1

IPX3/IPX6/VPX8, (1) grille brackets with hardware, vertical mount orientation, Ford Crown Victoria Police Package vehicles, '02 - '11



IPX-GRL2

IPX3/IPX6/VPX8, (1) grille brackets with hardware, horizontal mount orientation, Ford Crown Victoria Police Package vehicles, '02 - '11

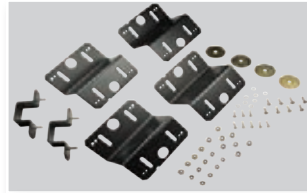

IPX-GRL3

IPX3/IPX6/VPX8, pair of grille brackets with hardware, 2011 Dodge Charger

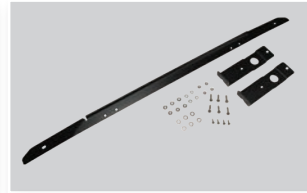

IPX-GRL4

IPX3-only, pair of grille brackets with each bracket holds (2) IPX3 light in a vertical orientation, 2011 Chevrolet Caprice

## Rear Side Window Brackets



IPX-SW1

IPX3/IPX8, pair of rear side window mount brackets, '02 - '11 Ford Crown Victoria Police Package vehicles



VPX-SW

VPX8, pair of rear side window mount brackets, each bracket hold (2) Viper EXT lights, late model Ford Crown Victoria Police Package vehicles



IPX-RDW2

IPX3/IPX6/VPX8, pair of rear side window mount brackets and covers, each bracket holds (2) IMPAXX or Viper Ext lights, Chevrolet Caprice



IPX-ROW1

IPX3/IPX6, pair of rear side "Opera" window mount brackets, Chevrolet Caprice



IPX-RSW1

IPX3/IPX6/VPX8, pair of rear side window mount brackets and covers, Dodge Charger



IPX-RSW2

IPX3/IPX6/VPX8, pair of rear side window mount brackets and covers, Chevrolet Caprice

## License Plate

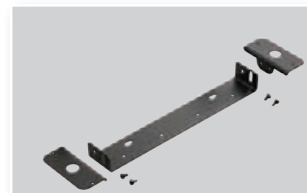

IPX-LPV1

IPX3/IPX6/VPX8, flat surface license plate mount, various vehicles without recessed plate mounting locations



IPX-LPVX1

IPX3/IPX6/VPX8, extended license plate bracket for vehicles with a recessed license plate mount location including but not limited to the '02 - '11 Ford Crown Victoria Police Package

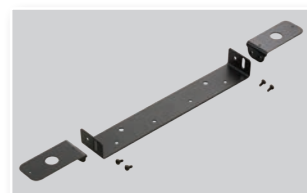

IPX-LPH1

IPX3/IPX6/VPX8, generic high side license plate holder with horizontal mount tab on each side, fits most vehicles

## Trunk Lid Brackets



IPX-TRNK1

IPX3/IPX6/VPX8, pair of inner trunk lid brackets with hardware, '02-'11 Ford Crown Victoria Police Interceptor package



IPX-TRNK2

IPX3/IPX8, pair of inner trunk lid brackets with hardware, '07 - '10 Dodge Charger



IPX-TRNK3

IPX3/IPX6/VPX8, pair of inner trunk lid brackets with hardware, 2011 Dodge Charger

## Push-bumper Brackets



IPX-PB45H

IPX3/IPX6/VPX8, pair of 45-degree slanted push bumper mounts with hardware, horizontal light orientation, fits most push bumpers



IPX-PB45V

IPX3/IPX6/VPX8, pair of 45-degree slanted push bumper mounts with hardware, vertical light orientation, fits most push bumpers

## Universal Mount

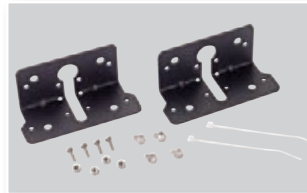

IPX-PBL1

IPX3/IPX6/VPX8, pair, universal "L" bracket, horizontal orientation

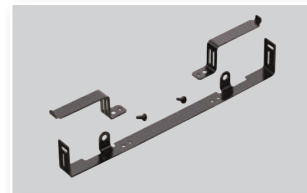

IPX-LPF1

IPX3 only, generic low side license plate holder for horizontal IMPAXX install, most vehicles



## MicroPulse™

- Multiple mounting options for various applications
- Super warning with (3) or (6) high-powered LEDs
- Low-profile design offers wider range of mounting locations
- 12 or 19 selectable flash patterns MicroPulse 3 or MicroPulse 6
- Single/multi-unit synchronization
- Dimensions: **MicroPulse 6**  
 4.2" (L) x 1.0" (H) x 1.6" (D) (hood/grille mount)  
 5.0" (L) x 1.1" (H) x 0.7" (D) (surface mount)  
**MicroPulse 3**  
 2.5" (L) x 1.0" (H) x 1.5" (D) (hood/grille mount)  
 3.4" (L) x 1.1" (H) x 0.7" (D) (surface mount)
- Three-year LED warranty



CLASS 1 CLASS 2

Model	Description
	<b>MicroPulse 6 (SAE J845 / J595 Class 1)</b>
	<b>Surface Mount, 12-24 VDC</b>
MPS600-AA	6-LED lighthead, Amber/Amber
MPS600-BB	6-LED lighthead, Blue/Blue
MPS600-RB	6-LED lighthead, Red/Blue
MPS600-RR	6-LED lighthead, Red/Red
MPS600-RW	6-LED lighthead, Red/White
MPS600-WW	6-LED lighthead, White/White
	<b>Hood/Grille Mount, 12-24 VDC</b>
MPS650-AA	6-LED lighthead, Amber/Amber
MPS650-BB	6-LED lighthead, Blue/Blue
MPS650-RB	6-LED lighthead, Red/Blue
MPS650-RR	6-LED lighthead, Red/Red
MPS650-RW	6-LED lighthead, Red/White
MPS650-WW	6-LED lighthead, White/White
	<b>MicroPulse 3 (SAE J845 / J595 Class 2)</b>
	<b>Surface mount, 12-24 VDC</b>
MPS300-A	3-LED lighthead, Amber
MPS300-B	3-LED lighthead, Blue
MPS300-R	3-LED lighthead, Red
MPS300-W	3-LED lighthead, White
	<b>Hood/Grille mount, 12-24 VDC</b>
MPS350-A	3-LED lighthead, Amber
MPS350-B	3-LED lighthead, Blue
MPS350-R	3-LED lighthead, Red
MPS350-W	3-LED lighthead, White



## 3600 LED Lights

- Watertight seal make each unit extremely durable
- Models may be synchronized with each other and other Federal Signal products
- Variety of mounting options
- Clear and color lens options
- SAE J845 Class 1
- Built-in selectable flash patterns
- LEDs offered in Amber, Blue, Red, and White
- Dimensions: 4.2" (L) x 1.8" (H) x 1.0" (D) (without bezel)
- Five-year LED warranty



360401-02

CLASS 1

Model	Description
	<b>Warning lights with Colored lens, wide prescription</b>
360401-02	Amber LED, Amber lens
360401-03	Blue LED, Blue lens
360401-04	Red LED, Red lens
	<b>Warning lights with Clear lens, wide prescription</b>
360411-02	Amber LED, Clear lens
360411-03	Blue LED, Clear lens
360411-04	Red LED, Clear lens
360411-05	White LED, Clear lens

### Kits

330501	Kit, plastic surface mount (pair)
330502	Kit, flush mount (pair)
330503	Kit, side mirror mount with rubber grommet (pair)
330504	Kit, dash/deck mount, plastic bezel (sold individually)
330505	Kit, cast bezel, surface mount (sold individually)
330507	Kit, grommet, 6"



330501



330502



330503



330504



330505



330507





## 7x3 QuadraFlare®

- Advanced Solaris® LED reflector technology in a 7x3 package
- Available with built-in flasher featuring a variety of OEM friendly selectable patterns
- LEDs offered in Amber, Blue, Green, Red, and White
- Optional chrome-plated trim bezel available
- Five-year LED warranty



CLASS 1 SOLARIS

Model	Description
<b>Warning lights with color lens and built-in flasher</b>	
QL73XF-(color)	Amber, Blue or Red
QL73XF-G	Green
<b>Warning lights with Clear lens and built-in flasher</b>	
QL73XFC-(color)	Amber, Blue or Red
QL73XFC-C	Clear
QL73XFC-G	Green
<b>Split-LED warning lights with color lens and built-in flasher</b>	
QL73SF-AA	Amber/Amber
QL73SF-BB	Blue/Blue
QL73SF-GG	Green/Green
QL73SF-RR	Red/Red

Model	Description
<b>Split-LED warning lights with Clear lens and built-in flasher</b>	
QL73SFC-AC	Amber/Clear
QL73SFC-BA	Blue/Amber
QL73SFC-RA	Red/Amber
QL73SFC-RB	Red/Blue
QL73SFC-RC	Red/Clear
QL73SFC-RG	Red/Green
QL73SFC-RR	Red/Red

Accessories	
QL73MC	Trim bezel, Chrome with gasket
QL73MB	Trim bezel, Black with gasket

Common Replacement Parts	
Z8012078A	Lens, fluted, Red; -02(Clear)
Z8012110A	Gasket, 7x3 base/lens, molded

## 6x4 QuadraFlare®

- Advanced Solaris® LED reflector technology in a 6x4 package
- LEDs available in Amber, Blue, Green, Red, and White
- Offered with built-in flasher featuring a variety of selectable patterns
- Optional chrome-plated trim bezel
- Brake/Tail/Turn, Turn Arrow and Back-up light models also available
- Five-year LED warranty



CLASS 1 SOLARIS

Model	Description
<b>Warning lights with color lens and built-in flasher</b>	
QL64XF-(color)	Amber, Blue, or Red
QL64XF-C	Clear
QL64XF-G	Green
<b>Warning lights with Clear lens and built-in flasher</b>	
QL64XFC-(color)	Amber, Blue, or Red
QL64XFC-G	Green
<b>Split-LED warning lights with color lens and built-in flasher</b>	
QL64SF-AA	Amber/Amber
QL64SF-BB	Blue/Blue
QL64SF-RR	Red/Red
QL64SF-GG	Green/Green
<b>Split-LED warning lights with Clear lens and built-in flasher</b>	
QL64SFC-(Color/Color)	Combinations of Amber/Blue/Red
QL64SFC-(Color/Color)	Combinations of Amber/Blue/Red with Green/ White
<b>Brake/Tail/Turn and Back-up lights</b>	
QL64Z-BTT	Brake/Tail/Turn, Red LED, Red lens
QL64Z-ARROW	Turn arrow, Amber LED, Amber lens
QL64Z-TURN	Turn light, Amber LED, Amber lens
QL64Z-BACKUP	Back-up light, White LED, Clear lens
<b>3-Position Vertical Casting</b>	
QL64Z3V-LEFT	Installed QL64Z-BTT, QL64Z-ARROW (left facing), QL64Z-BACKUP
QL64Z3V-RIGHT	Installed QL64Z-BTT, QL64Z-ARROW (right facing), QL64Z-BACKUP
QL64Z3V-LED	Installed QL64Z-BTT, QL64Z-TURN, QL64Z-BACKUP
QL64Z3V	Casting with gasket

Model	Description
<b>3-Position Horizontal Casting</b>	
QL64Z3H-LEFT	Installed QL64Z-BTT, QL64Z-ARROW (left facing), QL64Z-BACKUP
QL64Z3H-RIGHT	Installed QL64Z-BTT, QL64Z-ARROW (right facing), QL64Z-BACKUP
QL64Z3H-LEDLEFT	Installed QL64Z-BTT, QL64Z-TURN, QL64Z-BACKUP
QL64Z3H-LEDRIGHT	Installed QL64Z-BTT, QL64Z-TURN, QL64Z-BACKUP
QL64Z3H	Casting with gasket
<b>4-Position Vertical Casting</b>	
QL64Z4V-LEFT	Installed QL64Z-BTT, QL64Z-ARROW (left facing), QL64Z-BACKUP, QL64XF-R
QL64Z4V-RIGHT	Installed QL64Z-BTT, QL64Z-ARROW (right facing), QL64Z-BACKUP, QL64XF-R
QL64Z4V-LED	Installed QL64Z-BTT, QL64Z-TURN, QL64Z-BACKUP, QL64XF-R
QL64Z4V	Casting with gasket

Accessories and Kits	
QL64MHL	Headlight mount kit
QL64MC	Trim bezel, Chrome with gasket
QL64MB	Trim bezel, Black with gasket

Common Replacement Parts	
Z8012109A	Gasket, 6x4 base/lens molded
Z8012013B-01	Lens, fluted, 6x4, Amber; -02(Clear)



## 9x7 QuadraFlare®

- Advanced Solaris® LED reflector technology in a 9x7 package
- Features unique Quad-X patterns
- Available with built-in flasher featuring a variety of OEM friendly selectable patterns
- LEDs offered in Amber, Blue, Green, Red, and White
- Optional chrome-plated trim bezel available
- Five-year LED warranty



CLASS 1 SOLARIS

Model	Description
<b>GHSCENE</b>	
<i>9x7 GHSCENE lights</i>	
QL97HSCENE	Halogen SCENE
QL97LEDSCENE	LED SCENE
<b>QuadraFlare</b>	
<i>9x7 Warning lights with color lens and built-in flasher</i>	
QL97XF-(color)	Amber, Blue or Red
QL97XF-G	Green
<i>9x7 Warning lights with Clear lens and built-in flasher</i>	
QL97XFC-(color)	Amber, Blue or Red
QL97XFC-C	White
QL97XFC-G	Green
<i>9x7 Split-LED warning lights with color lens and built-in flasher</i>	
QL97SF-AA	Amber/Amber
QL97SF-BB	Blue/Blue
QL97SF-GG	Green/Green
QL97SF-RR	Red/Red

Model	Description
<i>9x7 Split-LED warning lights with Clear lens and built-in flasher</i>	
QL97SFC-AA	Amber/Amber
QL97SFC-AC	Amber/Clear
QL97SFC-BA	Blue/Amber
QL97SFC-BB	Blue/Blue
QL97SFC-BC	Blue/Clear
QL97SFC-CC	White/White
QL97SFC-GG	Green/Green
QL97SFC-RA	Red/Amber
QL97SFC-RB	Red/Blue
QL97SFC-RC	Red/White
QL97SFC-RG	Red/Green
QL97SFC-RR	Red/Red

### Accessories

QL97MB	Trim bezel, Black with gasket
QL97MC	Trim bezel, Chrome with gasket

### Common Replacement Parts

Z8012062C-02	Lens, fluted, Clear
Z8012111A	Gasket, 9X7 base/lens, molded

## In-Line Corner LED Systems

- Built-in (19) selectable flash patterns
- Multiple units can be synchronized and can flash simultaneously or alternately
- Maintenance free
- Low-profile design
- Three-year product warranty



Model	Description
416200-22	Amber/Amber, (2) LED heads with In-Line flasher
416200-33	Blue/Blue, (2) LED heads with In-Line flasher
416200-44	Red/Red, (2) LED heads with In-Line flasher
416200-55	Clear/Clear, (2) LED heads with In-Line flasher

### Common Replacement Parts

416201-02	LED lighthouse, Amber
416201-03	LED lighthouse, Blue
416201-04	LED lighthouse, Red
416201-05	LED lighthouse, Clear
416205	Flasher with cable, 2-channel



## Silver Series™ SLD Systems

- 460L and 660L have built-in LED flashers to synchronize LED modules with strobe head action
- Variety of flash patterns available
- Prioritized three-mode operation (460L/660L)
- Industry standard connectors supplied with all units
- Three-year product warranty



Model	Description
<b>Silver Series Strobe Power Supplies</b>	
415205	SS2W, two-channel, Weatherpack connectors
415207	SS2A, two-channel, Amp connectors
416104	460L, four-head, 60W, synchronized LED Flasher
416106	660L, six-head, 60W, synchronized LED Flasher
416108	SS4W, four-head, 50W, multiple patterns, Weatherpack connectors
416109	SS4A, four-head, 50W, multiple patterns, Amp connectors
<b>Strobe Systems/Kits with AMP connectors</b>	
416110B	(1) 460L, (4) Clear corner tubes, (2) 10-ft cables, (2) 25-ft cables
416111	(1) 460L, (4) Clear corner tubes, (2) 16-ft cables, (2) 30-ft cables
416118	(1) 660L, (4) Clear corner tubes, (4) 16-ft cables
416119B	(1) 660L, (4) Clear corner tubes, (2) 10-ft cables, (2) 25-ft cables
416120	(1) 660L, (4) Clear corner tubes, (2) 16-ft cables, (2) 30-ft cables
416125B	(1) SS4A, (4) Clear corner tubes, (2) 10-ft cables, (2) 25-ft cables
416127	(1) SS4A, (4) Clear corner tubes, (2) 16-ft cables, (2) 30-ft cables
416129	(1) SS4A, (4) Clear corner tubes, (4) 16-ft cables
416129-25	(1) SS4A, (2) Clear corner tubes, (2) Amber corner tubes, (4) 16-ft cables
416133-25	(1) SS4A, (2) Clear corner tubes, (2) Amber corner tubes, (2) 16-ft cables, (2) 30-ft cables
416133-45	(1) SS4A, (2) Clear corner tubes, (2) Red corner tubes, (2) 16-ft cables, (2) 30-ft cables
416139	(1) SS2A, (2) Clear corner tubes, (2) 16-ft cables
416140	(1) SS2A, (2) Clear corner tubes, (2) 30-ft cables
<b>Strobe Systems/Kits with Weatherpack connectors</b>	
416126	(1) SS4W, (4) Clear corner tubes, (2) 16-ft cables, (2) 30-ft cables
416128	(1) SS4W, (4) Clear corner tubes, (4) 16-ft cables
416132B	(1) SS4W, (4) Clear corner tubes, (2) 10-ft cables, (2) 25-ft cables

### Accessories and Kits

<b>Strobe heads, AMP connectors</b>			
413201	Corner strobe tube, Silver Series, 1" diameter rubber grommet, amp connector; -02 (Amber); -03 (Blue); -04 (Red)		
413201-05	Corner strobe tube, Silver Series, 1" diameter rubber grommet, amp connector, Clear		
<b>Strobe heads, Weatherpack connectors</b>			
413300	Corner strobe tube, Silver Series, 1" diameter rubber grommet, Weatherpack connector; -02 (Amber); -03 (Blue); -04 (Red)		
413300-05	Corner strobe tube, Silver Series, 1" diameter rubber grommet, Weatherpack connector, Clear		
<b>Strobe Cables</b>			
413124	Bulk packaging amp connector kit (approximate installation capacity of (5) vehicles)		
413202	Kit, adapter cables, strobe power supply, (2) 12" cables		
<b>Silver Series, cable kit, AMP connectors</b>			
413210	10-ft cable length	413230	30-ft cable length
413216	16-ft cable length	413241	40-ft cable length
413222B	25-ft cable length	413251	50-ft cable length
<b>Silver Series, cable kit, Weatherpack connectors</b>			
413310	10-ft cable length	413330	30-ft cable length
413316	16-ft cable length	413340	40-ft cable length
413322B	25-ft cable length	413350	50-ft cable length
<b>Silver Series, cable kit, AMP and Weatherpack connectors</b>			
413410	10-ft cable length	413422B	25-ft cable length
413416	16-ft cable length	413430	30-ft cable length

### Notes

- Purchase cables separately unless otherwise noted, one per strobe head.
- Models 413410, 413416, 413422B, 413430, 413440, and 413450 require Weatherpack strobe tube 413300.
- Power supplies with Weatherpack connectors are only compatible with cables and strobe heads with Weatherpack connectors.
- Purchase cables separately unless otherwise noted, one per strobe head.
- Equipment provided with Amp connectors unless being noted as Weatherpack.



## Signaltech® LED Lights

- Reflector cell technology enhances brightness and reduces sunlight washout
- Solid-state components are potted to withstand rugged road conditions
- Sealed wiring harness
- Random, alternating or synchronous flash patterns
- Flashing: SAE J595 (SAE J1318, 2009)
- S/T/T and back-up/turn: FMVSS 108 compliant, SAE J1398, and SAE J593
- Three-year warranty



CLASS 1

Model	Description
<b>Random Flashing LED Light Kits, 12-24VDC, 71 quad FPM</b>	
<b>4" Round LED Light Kits (kits includes LED light, rubber mounting grommet, sealed wire harness)</b>	
607112-02	PAR 36 with rubber tractor housing, Amber; -04(Red)
607112-03	PAR 36 with rubber tractor housing, Blue
607123-02	PAR 36, Amber
607123-03	PAR 36, Blue
<b>5" Round LED Light Kits (kits includes LED light, rubber mounting grommet, sealed wire harness)</b>	
607126-02	PAR 46, Amber
607127-02	PAR 46 with rubber tractor housing, Amber
<b>6" Oval LED Light Kit (kits includes LED light, rubber mounting grommet, sealed wire harness)</b>	
607101-02	Amber; -04(Red)
607101-03	Blue
<b>Synchronous Flashing LED Light Kits, 12-24VDC, 72 quad FPM</b>	
<b>4" Round LED Light Kits</b>	
607133-02	PAR 36, Amber LED with Amber lens
607133-25	PAR 36, Amber LED with Clear lens
<b>6" Oval LED Light Kit</b>	
607134-02	Amber LED with Amber lens
607134-25	Amber LED with Clear lens
<b>Alternating Flashing LED Light Kits, 12-24VDC, 72 quad FPM</b>	
<b>5" Round LED Light Kit</b>	
607140-02	PAR 46, Amber
<b>6" Oval LED Light Kit</b>	
607139-02	Amber LED with Amber lens
<b>Random Flashing LED Light Kits, 12-24VDC, 120 single FPM</b>	
<b>4" Round LED Light Kits</b>	
607128-02	PAR 36, Amber
<b>5" Round LED Light Kits</b>	
607130-02	PAR 46, Amber
607131-02	PAR 46 with rubber tractor housing, Amber
<b>6" Oval LED Light Kit</b>	
607129-02	Amber

Model	Description
<b>S/T/T and Back-up Lights</b>	
<b>4" Round LED Light Kits (kits includes LED light, rubber mounting grommet, sealed wire harness)</b>	
607100-04	LED Stop/Tail/Turn light, 12-24V, Red
607102-02	LED turn light, 12-24V, Amber
607124-05	LED back-up light, 12-24V, White
607141-04	LED Stop/Tail/Turn light, 12V only, Red
607141-05	LED Stop/Tail/Turn light, 12V only, White
<b>6" Oval LED Light Kits (kits includes LED light, rubber mounting grommet, sealed wire harness)</b>	
607105-04	LED Stop/Tail/Turn light, 12-24V, Red
607106-02	LED turn light, 12-24V, Amber
607125-05	LED back-up light, 12-24V, White
607142-04	LED Stop/Tail/Turn light, 12V only, Red
<b>Side Marker/Clearance Lights, 12VDC</b>	
607120-02	2.5" round, Amber; -04(Red)
<b>Accessories and Kits</b>	
605501-02	6" oval flashing LED light head, Amber; -04(Red)
605520	Kit, rubber mounting grommet, 4" round
605510	Kit, rubber mounting grommet, 6" oval
605523-02	4" round flashing LED light head, Amber;
605500	Sealed wire harness for flashing LED light heads
607103-04	4" round LED S/T/T light head
607109	Sealed wire harness for S/T/T and Turn LED light heads
607110	Kit, anti-theft stainless steel flange, 4" round
607111	Kit, anti-theft stainless steel flange, 6" oval
607137	Kit, rubber mounting grommet, PAR 46, 5" round
607145	Harness with load resistor



607125-05



607123-02  
(shown in optional bracket, 601320)



607101-02  
(shown in optional bracket, 601330)



## Grille Lights

- Compact light heads can be mounted behind or in front of the grilles of most vehicles
- Durable, fully enclosed polycarbonate housing provides protection
- Three-year product warranty



Model	Description
	<b>LED models with color lenses, built-in flasher</b>
GL1-A	Amber LEDs, Amber lens
GL1-B	Blue LEDs, Blue lens
GL1-R	Red LEDs, Red lens
	<b>LED models with color lenses, require external flasher</b>
GL2-A	Amber LEDs, Amber lens
GL2-B	Blue LEDs, Blue lens
GL2-R	Red LEDs, Red lens
<b>Accessory</b>	
650205	LED Flasher, (2) 10 amp channels, (10) flash patterns, high-side switching

## Mount Boxes

- ABS, cold rolled steel and stainless steel mount boxes
- Boxes can be welded or bolted to vehicle body (mounting hardware not included)
- Fits LED, strobe or incandescent oval lightheads (round available in ABS style only)



Model	Description
	<b>Cold rolled steel (with zinc plating), oval</b>
305101	1-up, pair
305102	2-up, pair
305103	3-up, pair
	<b>Stainless steel, oval</b>
305111	2-up, pair
305112	3-up, pair
	<b>ABS (Black color), oval</b>
305104	1-up, sold individually
	<b>ABS (Black color), round</b>
305107	1-up



## Viper® S2

- Solaris® LED reflectors provide bold blocks of light and superior off-axis warning capability
- Single and dual light head models
- Cigarette plug with LED on/off switch and synchronized models
- Simple push-button pattern control and 2-phase pattern synchronization
- Versatile mounting brackets with “snap-on” flash guard
- Library of more than 20 flash patterns
- Five-year product warranty



Model	Description
	<b>Single-head models with cigarette plug</b>
329000	-2(Amber)
329000	-5(White)
	<b>Single-head models with wire leads (synchronization capable)</b>
329001	-2(Amber)
329001	-5(White)
	<b>Dual-head models with cigarette plug</b>
329000-22	Amber/Amber
329000-25	Amber/White
329000-52	White/Amber
	<b>Dual-head models with wire leads (synchronization capable)</b>
329001-22	Amber/Amber
329001-25	Amber/White
329001-52	White/Amber

## FireBeam®

- Front, rear deck or auxiliary warning light
- 68,000 Candela output from 55-watt halogen bulb
- Single and dual speeds
- Compact, lightweight and easy to install
- Standard equipped with cigarette plug connector
- Five-year rotator warranty



Model	Description
	<b>Single-speed models with magnet mount and cigarette plug LED indicator</b>
FB3MEF	175 FPM, -A(Amber); -B(Blue); -C(Clear)
	<b>Single-speed models with heavy-duty magnet mount and cigarette plug LED indicator</b>
FB3MEF-RHDMC	175 FPM, Red only
	<b>Compartment Warning Light</b>
FB3COMP-R	95 FPM, Red

### Accessories

UF7	Ultra-Flash mirror, seven flash effect
FB3C	Half dome cover, -A(Amber); -B(Blue); -R(Red)

### Common Replacement Parts

Z8440A265A-02	Bulb, rotator/oscillating light, 55W
Z8550137A	Dome, FireBeam, Clear; -01(Red); -02(Amber); -03(Blue)
Z8559A055A	Motor, FireBeam, 95 FPM
Z8559A055A-01	Motor, FireBeam, 175 FPM

## Littlite®

- Durable, high quality lighting for a vehicle's console
- Flexible gooseneck allows easy movement
- Clear bright light with either rheostat or on/off switch controls
- LED or halogen models available
- LED units offer choice of Red or White light from toggle switch selector
- Green or Red filters available
- Available in 12" and 18" models
- Two-year warranty on LED models



Model	Description
<b>LED Littlite Models</b>	
<i>Neck extends from end of chassis, vertical mount</i>	
LF12ES-LED	12", On/Off switch control
LF18ES-LED	18", On/Off switch control
<b>Halogen Littlite Models</b>	
<i>Neck extends from top of chassis, horizontal mount</i>	
LF12TR	12" Rheostat control
LF18TR	18", Rheostat control
<b>Common Replacement Parts</b>	
Z8550250A	Lamp, bi-pin
Z8550251A	Filter, Red; -01(Clear); -02(Green)
LFHK	Hood kit

## LED Compartment Light

- LED, 12-24V
- Three-year LED warranty



Model	Description
607141-05	Round 4" white LED compartment light (kits include LED light head, black mounting grommet and sealed wire harness)



## 9x7 Scene Light

- Available in halogen or LED models
- Surface mounted LED models
- LED models feature Solaris® LED reflector technology
- Industry standard mounting dimensions
- Five-year warranty



Model	Description
QL97HSCENE	Area light, halogen
QL97LEDSCENE	Area light, LED, surface mount
<b>Common Replacement Parts</b>	
Z8012075B	Lens, fluted, Clear

## Wireless VisiBeam® / VisiBeam®

- High-power spotlight for superior work area illumination
- Ergonomically designed wireless transmitter operates at over 100-ft (wireless)
- Up to four transmitters programmable to operate one light (wireless)
- Graduated start for pinpoint light beam placement
- Continuous 360-degrees horizontal and 140-degrees vertical adjustment
- Three-year warranty



Model	Description
<b>Wireless VisiBeam</b>	
<b>12VDC, 100W, wireless controller</b>	
620200	Permanent mount
620201	Magnetic mount with cigarette lighter plug
<b>24VDC, 65W, wireless controller</b>	
620202	Permanent mount
<b>VisiBeam II</b>	
620102	55W, 12VDC, adjustable spot light surface mount
620104	65W, 24VDC, adjustable spot light, surface mount
620122	100W, 12VDC, adjustable spot light, surface mount
620142	100W, 12VDC, adjustable spot light, magnetic mount with cord and cigarette plug
620152	100W, 12VDC, adjustable spot light, pipe mount

<b>Common Replacement Parts</b>	
620502	Bulb, 12VDC, 100W, for models 620122, 620142, 620152, 620200 and 620201
620504	Bulb, 24VDC, 65W, for models 620104 and 620202
620510	Bulb, 12VDC, 55W, for model 620102
448500-05	Dome, Clear
Z146903B	Cable assembly, 25-ft
Z8433039B	Remote control
Z8422B399A-01	Motor, 12VDC
Z8422528A	Motor, 24VDC
Z8433113A	Transmitter, wireless



## GHSCENE®

- Two 20-watt halogen fixtures adjust vertically & horizontally for maximum effectiveness
- Internal electrical connections are protected from outside elements for increased service life
- Thick foam gasket provides snug seal even on diamond plate surface
- Replacement lamps are available at local hardware centers
- Three-year warranty



GHSCENE

Model	Description
GHSCENE	Area Light, GHSCENE, (2) 20W adjustable lamps, Clear lens
<b>Accessory</b>	
GHFLANGE	Rectangular shaped GHSCENE trim ring
<b>Common Replacement Parts</b>	
Z8575105A	Trim ring, chrome
Z8575107A	Lamp and reflector assembly, 20W, 35-degrees
Z8575108A	Lens, Clear

## Tractor and Utility

- High powered sealed beam and halogen work lights
- Available in 4.75" - PAR 36, 6.50" - PAR 46 and rectangle
- Adjustable vertical and horizontal mounts
- Vibration resistant construction
- Resistant to heat and inclement weather
- Heavy gauge metal brackets
- Standard flood beam pattern
- Three-year product warranty



325541



325039

Model	Description
<b>4.75" PAR 36</b>	
325039	Work lamp, 12.8VDC, 4.3A, 55W, round, halogen, flood pattern, 4.8" (diameter) x 2.8" (depth)
325048	Utility lamp, 12.8VDC, 2.7A, 35W, round, sealed beam incandescent, flood pattern, magnetic mount with cigarette plug, 4.8" (diameter) x 3.0" (depth)
<b>6.50" PAR 46</b>	
323552	Utility lamp, 12.8VDC, 7.7A, 100W, round, high-intensity, sealed beam incandescent, 6.5" (diameter) x 4.4" (depth)
<b>Rectangular</b>	
325541	Work lamp, 12.8VDC, 3.9A, 50W, sealed beam incandescent, flood pattern, 7.5" x 5.0" x 5.2"
325542	Work lamp, 12.8VDC, 3.9A, 50W, halogen, flood pattern, 7.5" x 5.0" x 5.2"
<b>Accessories</b>	
360800	Wire guard for PAR 36 models
360900	Wire guard for PAR 46 models
<b>Common Replacement Parts</b>	
325045	4.75" rubber housing with bolt
325046	6.50" rubber housing with bolt
620504	Bulb, H3, 24VDC, 65W
620510	Bulb, H3, 12VDC, 55W

## 2012 Series Back-up Alarms

- Available in 87 dB(A), 97 dB(A), and 102 dB(A) models with wires or stud terminals
- Built-in universal mounting bracket with industry-standard 3.25" centers and self-grounding strap (on "-S" models) eases installation
- Alarms operate at 12-24 VDC drawing only 0.5A
- Meet SAE J994, CE, OSHA, and MSHA requirements
- Steam-cleanable and pressure washable
- Epoxy encapsulation protects against vibration, as well as debris and moisture ingress
- Three-year product warranty



Model	Description
210238-S	87 dB(A), 12-24VDC, SAE J994 Type D, stud terminals
210238-W	87 dB(A), 12-24VDC, SAE J994 Type D, wires
210239-S	97 dB(A), 12-24VDC, SAE J994 Type C, stud terminals
210239-W	97 dB(A), 12-24VDC, SAE J994 Type C, wires
210240-S	102 dB(A), 12-24VDC, SAE J994 Type F, stud terminals
210240-W	102 dB(A), 12-24VDC, SAE J994 Type F, wires

## Evacuator® Back-up Alarms

- Meet SAE J994, OSHA, and MSHA requirements
- "Plus" models offer dual-tone function (pulse or constant)
- A wide range of decibel levels and operating voltages is offered for enhanced application flexibility
- Universal mounting bracket included
- Maximum current draw of 0.15 A
- Unique piezo electric design incorporates a tear-free Mylar speaker cone that is impervious to moisture
- Solid-state electronics and a sealed design protect against moisture, contaminants and vibration
- Three-year product warranty



210331  
607102-02

Model	Description
210341	<b>Evacuator, Single Functions, 12-24VDC</b> 107 dB(A), 12-24VDC, SAE J994 Type B, nickel-plated threaded terminals
210330	<b>Evacuator Plus, Dual Functions, 12-48VDC</b> 87 dB(A), 12-48VDC, SAE J994 Type D, nickel-plated threaded terminals
210331	97 dB(A), 12-48VDC, SAE J994 Type C, nickel-plated threaded terminals
210333	107 dB(A), 12-48VDC, SAE J994 Type B, nickel-plated threaded terminals
210335	112 dB(A), 12-48VDC, SAE J994 Type A, nickel-plated threaded terminals

## Reactor Series Back-up Alarms

- Automatically adjust to at least 5dB(A) above ambient noise level (210502 is manually adjustable)
- Epoxy-sealed for protection against vibration, dirt and moisture
- Glass-filled nylon housing is steam-cleanable
- Integrated universal mounting bracket
- Maximum current draw between 0.2 A and 1.0 A
- Meet SAE J994, OSHA and MSHA requirements
- Three-warranty product warranty



210350

Model	Description
210350	77-102 dB(A), auto-adjusting, 12-24VDC, SAE J994 Type E-F, 4.02" x 2.64" x 1.60"
210502	107 or 112 dB(A), manually adjustable, 12-24VDC, SAE J994 Type B or A, 5.00" x 3.06" x 3.78"
210504	87-112 dB(A), auto-adjusting, 12-24VDC, SAE J994 Type D-A, 5.00" x 3.06" x 3.78"
210505	87-107 dB(A), auto-adjusting, 12-48VDC, SAE J994 Type D-B, 5.00" x 3.06" x 3.78"

## Two-Tone Alarms

- Provide moving equipment warning for applications light lift gates, stabilizing outriggers and over-head cranes — not designed for vehicular back-up
- Produce a simultaneous, dual-tone (2.5/2.7 kHz) warning signal
- Solid-state electronics and a sealed design to protect against moisture, contaminants and vibration
- Consume less than 0.5A
- Three-year product warranty



210361

Model	Description
210358	87 dB(A), 12-48VDC
210361	97 dB(A), 12-48VDC
210363	107 dB(A), 12-48VDC
210365	112 dB(A), 12-48VDC

## Grommet-mount Alarms

- 4 1/2-inch industry-standard grommet-mounting for quick and easy installation
- Solid-state electronics are fully encapsulated for consistent on-the-job reliability
- Tough fiberglass-filled nylon housing can be mounted in a vertical or horizontal orientation and is steam-cleanable
- Meet SAE J994, OSHA and MSHA requirements
- One-year product warranty



Model	Description
210344	97 dB(A), 12-24VDC, SAE J994 Type C, with 4-1/2" grommet, 4.3" (diameter) x 2.0" (depth)
210345	107 dB(A), 12-24VDC, SAE J994 Type B, with 4-1/2" grommet, 4.3" (diameter) x 2.0" (depth)

## Switch

- For installations where it is not possible to wire a back-up alarm into the vehicle's back-up light circuit
- Installed adjacent to the gear-shift lever or linkage, the switch activates the alarm when the activating shaft is moved



Model	Description
210298	Multi-directional 360° switch, 5A, water-resistant, with adjustable mounting bracket
210299	Unidirectional switch, 5A
200053-95	Replacement mounting bracket for 210298 switch



## Mobile Camera Systems

- All cameras are high-resolution, color Sony CCD cameras
- TFT-LCD color monitors available in 5.6" or 7.0"
- Most cameras equipped with automatic day/night sensor and infrared LEDs for night vision

- Multiple camera cable lengths available
- Digital Video Recorder (DVR) with video and audio feed available
- Wide operating temperature range for all cameras: -22°F to 149°F
- Multi-voltage capability (12/24 VDC)
- Two-year warranty

Model	Description
-------	-------------

<b>Systems</b>	
CAMSET56-NTSC-2	5.6" Monitor with two-camera input, (1) standard rear-view camera, (1) 65.5-ft extension cable
CAMSET70-NTSC4B	7.0" Monitor with four-camera input, (1) standard rear-view camera, (1) 65.5-ft extension cable
<b>Monitors</b>	
CAMLCD-70	7.0" TFT-LCD monitor (for use with CAMDVR-SD or CAMDVR-4-B)
CAMLCD-INT-56	5.6" TFT-LCD monitor with two camera inputs
CAMLCD-INT-70-B	7.0" TFT-LCD monitor with four camera inputs and intelligent split-screen capability
CAMLCD-MIR	4.3" TFT-LCD rear-view mirror monitor with two camera inputs
<b>Cameras - Camera cables sold separately</b>	
CAMCCD-REARNTSC	Standard rear-view CCD camera with photosensor, 16 infrared LEDs, and microphone, IP68
CAMCCD-SIDENTSC	Standard rear-view CCD camera with photosensor, 16 infrared LEDs, and microphone, IP68
CAMCCD-FLSHNTSC	Bullet/flush-mount CCD camera, IP68, U-bracket included
CAMCCD-FLS2NTSC	Bullet/flush-mount CCD camera with photosensor & 10 infrared LEDs for night vision, IP68
CAMCCD-BALLNTSC	Standard rear-view CCD camera with photosensor & 16 infrared LEDs for night vision, microphone, IP68
CAMCCD-DOMENTSC	Dome CCD camera with photosensor & 18 infrared LEDs for night vision, microphone, IP65
<b>Digital Video Recorders</b>	
CAMDVR-4-B	Digital video recorder, 250GB hard drive, (2) 33-ft & (2) 45-ft camera cables
CAMDVR-SD	Digital video recorder, 32GB SD card, (2) 33-ft & (2) 45-ft camera cables
<b>Cables</b>	
CAMCABLE-5	Camera-to-monitor extension cable, 16.5-ft/5-m
CAMCABLE-10	Camera-to-monitor extension cable, 33-ft/10-m
CAMCABLE-15	Camera-to-monitor extension cable, 49-ft/15-m
CAMCABLE-20	Camera-to-monitor extension cable, 65.5-ft/20-m
CAMCABLE-40	Camera-to-monitor extension cable, 131-ft/40-m
CAMCABLE-TRK	Truck/trailer camera connection kit
CAMCABLE-SHORT	Camera-to-monitor extension cable, 4-in/102-mm

### Accessories and Kits

CAMADP-EXT	Camera cable adapter for connecting two camera-to-monitor extension cables together
CAMADP-RCA-IN	System adapter for connecting external RCA - equipped video source to FS monitor or DVR
CAMADP-RCA-OUT	System adapter for connecting CAMCCD-XXXXNTSC to external RCA destination input
CAMBRK-HD	Heavy-duty monitor mount
CAMLCD-BRACKET	Replacement mounting bracket for monitor
CAMADP-Y-2	System adapter for splitting camera or monitor into two branches

### Common Replacement Parts

CAMADP-INT-2	Replacement wiring harness, CAMLCD-INT-56/CAMLCD-INT-70
CAMADP-INT-4	Replacement wiring harness, CAMLCD-INT-70-B



CAMCCD-FLSHNTSC  
Bullet/Flush mount



CAMCCD-FLS2NTSC  
Flush mount  
with IR LEDs



CAMCCD-SIDENTSC  
Side mount



CAMCCD-REARNTSC  
Standard rear-view



CAMCCD-DOMENTSC  
Dome  
(indoor use only)



CAMCCD-BALLNTSC  
Ball mount

CAMDVR-SD  
Digital Video  
Recorder



CAMLCD-MIR  
Rearview mirror  
monitor

## Headlight / Taillight Flashers

- Headlight and taillight flashers are available for high-side and ground switched systems
- "Plug-n-play" models available
- Multiple flash rates
- Easy to install
- Three-year product warranty



FHL2-SC



FHL-HL



FHL-TAIL

Model	Description
	<b>High-Side switched headlight flasher systems</b>
FHL2-SC	Flasher, headlight, 90 FPM, standard headlight system, high beam override (2) 10A loads
FHL-HL	Flasher, headlight, multiple flash patterns, (2) 10A outputs, 18" wire leads
	<b>High-Side switched taillight flasher system</b>
FHL-TAIL	Flasher, taillight, low stand-by current draw, multiple flash patterns

## Intelli-Flash® Flashers

- Specifically designed for use with auxiliary LED lighting
- Designed to perform in a variety of applications
- Can be used to synchronize multiple light heads
- Three-year product warranty

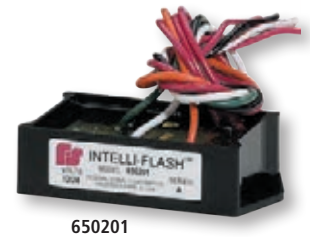

650201

Model	Description
	<b>Intelli-Flash Series flashers (auxiliary lighting flashers - do not use for headlight or taillight applications)</b>
650201	(2) 6A loads, (8) flash patterns, ground-side switching
650202	(4) 4A loads, (8) flash patterns, ground-side switching
650205	(2) 10A loads, (10) flash patterns, high-side switching
FA3-SC	90 FPM, (2) 10A loads, high-side switching

## Mounting Bars

- Mounts any type of warning light, directional light, or work light
- Accommodates mini-lightbars, as well as full-length lightbars
- Sliding carriage bolt design for ease of installation when mounting any lighting device
- Available for permanent mount or hook-on mount applications
- Available in 46", 54" and 65" lengths



(lightbar sold separately)

Model	Description
210960-46	46", Roof mount bar
210960-54	54", Roof mount bar
210960-65	65", Roof mount bar

### Accessories and Kits

UNPK	Mounting kit, permanent
UNHK	Mounting kit, hook mount feet (requires use of hook kit)
HKB-(Model)	Hook required with hook-on mount, (specify vehicle)—see page 21
210962	Kit, mounting bar endcap (contains endcap and two screws)
210961	Kit, mounting plate, beacon (mounts LED, strobe, and halogen beacons and VisiBeams)
454219	Kit, roof mount bar (must be used when mounting HighLighter on a Roof Mounting bar)

## Switch Controls

- Switching of up to seven auxiliary functions
- 20 Amp fuses and 20 amp switches are standard
- Standard, high current slide switch and non-slide switch models available
- Backlit or LED function identification
- Easy installation
- Three-year warranty



Model	Description
<b>“SW” Switch Control Panel Models</b>	
SW1	One rocker switch
SW2	Two rocker switch
670132	Three rocker switches
SW200-012	SW200 Series, (4) 20A fused switches
SW200-BK1	SW200 Series, SW200-012 control panel and SW-BK1 mount bracket
SW30	SW30 Series, (3) 20A toggle switches on L bracket housing
SW300-012	SW300 Series, (1) 40A and (5) 20A fused switches
SW300-BK	SW300 Series, SW300-012 control panel and SW-BK mount bracket
SW400SS	SW400 Series, slide control and (4) 20A switches
<b>Toggle Switch Models</b>	
210620	Toggle switch, Black
210633	Toggle switch, Chrome on metal

### Accessories and Kits

SW-BK1	Mount bracket for SW200-012
SW-BK	Mount bracket for SW300-012 and SW400SS
210624	Single-hole switch panel for use with 1/2" diameter toggle switches

### Common Replacement Parts

671512	Rocker switch, 20-amp, illuminated
671522	Toggle switch
Z122374A	Slide-switch
Z122283A	Rocker switch, 20A, momentary
Z122385B	Rocker switch, 20A, on/off, illuminates, Red
Z124102A	Kit, circuit breaker, 40A
Z124A058A	Kit, multiple legends, backlit

## Ignition Delay Timer

- Protects vehicle battery when lighting equipment is on and vehicle engine is off
- Adjustable time settings ranging from 1,3,4 or 6 hours
- Simple and quick installation
- Ideal for areas with “no-idle laws” in place
- Three-year warranty



Model	Description
750000-T1	60 Amp Ignition Delay Timer



Z211800B  
Replacement flash tube Model 1262/1682



Z8107141A  
Lamp, rotator, vertical filament, 795X, 50W, bayonet

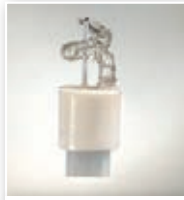

Z8107146C  
Strobe tube, Fireball



Z8107152A  
Bulb, H3 halogen, 55W 12VDC



Z8107156A  
Bulb, 25W, G4, 12V, halogen, GH1



Z8107158A  
Bulb, H3 halogen, 100W, 12VDC



Z8107165A  
Bulb, 35W, G4, 12V, halogen, GH1F



Z8107169A  
Bulb, GH8, Bi-pin alley/takedown light, 50W halogen



Z8107170A  
Bulb, GH9, Bi-pin flashing light, 35W halogen



Z8107232A  
Strobe tube assembly, 413250/GS1/GS1F



Z8107241A  
Lamp, alley, Arjent SL, MR11, 10-degrees



Z8107A027  
Bulb, 4505, 50W, 24VDC, Model 14



Z8107A033  
Bulb, 4416, 30W, Model 14



Z8107A095A  
Bulb, Stop/Tail/Turn, GE1157, dual filament



Z8107A119A  
Bulb, alley/takedown light, horizontal filament, 50W bayonet



Z8440A265A-02  
Bulb, Rotator, H1 vertical filament, long life, 12VDC



Z8444A151A  
Bulb, H1, vertical filament, 70W halogen, 24VDC



Z8548A028A  
Bulb, flashing light, horizontal filament, 796, 35W



Z8550250A  
Lamp, Littlite, Bi-pin



Z8550269A  
Replacement flash tube, Firebolt



Z8560082A  
Strobe assembly, Highlighter Strobe



Z8573007A  
Bulb, GH22 Bi-pin, SignalMaster, 27W halogen



Z8575067A  
Strobe tube and reflector assembly, GS2



Z8575107A  
Lamp and reflector assembly, GHSCENE



Z8583052A  
Strobe tube, Vistabeam/directional, helical, lower level



Z8583292A  
Strobe tube and reflector assembly, linear, upper level

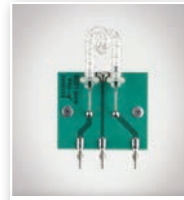

211200-95  
Replacement flash tube, Model 651/901

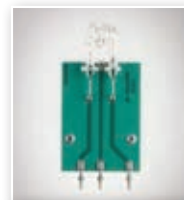

211400-95  
Replacement flash tube, Model 851/951



413201-05  
Strobe tube, Ricochet/Silver Series Clear with amp connector



439290-95  
Replacement flash tube, 551 HD



439411-95  
Replacement flash tube, 451 HD



462510  
Strobe tube assembly, Renegade



521592  
Strobe tube and reflector assembly, JetStrobe



602111-02/03/04  
Corner strobe tube, Amber, Blue, or Red CS1



602111-05  
Corner strobe tube, Clear CS1



8107230A-95  
Replacement flash tube, Model 401

# Legend® LPX Discrete



- Solaris® LED reflector technology
- Traditional nine-conductor cable
- All-LED lightbar — LED work lights and S/T/T lights available
- LEDs offered in Amber, Blue, Green, Red, and White
- Top domes offered in Amber, Blue, Clear, and Red
- Independently controlled front and rear flashing
- Ten (10) selectable flash patterns; Two (2) flashing modes
- Available in 24", 45", 53", 61" and 70" lengths
- Five-year LED warranty

**CLASS 1**

Online Lightbar Configurator

**ROC**  
RELIABLE ORIGINAL CONDUCTOR CABLE

**SOLARIS**

Model	Description
	<b>53" Models - Traditional cable</b>
LPX53D-00001	Clear/Clear/Clear, (4) Amber corner LED reflectors, (2) LED work lights, (2) LED S/T/T lights
	<b>61" Models - Traditional cable</b>
LPX61D-00005	Clear/Clear/Clear/Clear, (4) Amber 5" LED reflectors, (4) Amber 4" LED reflectors, (4) Amber corner LED reflectors, (2) LED work lights, (2) LED S/T/T lights
LPX61DNC-00001	Clear/Clear/Clear/Clear, (6) Amber 5" LED reflectors, (4) Amber corner LED reflectors, (2) LED work lights, (2) LED S/T/T lights

### Accessories and Kits

HKB-(Model)	Hook required with hook-on mount, specify vehicle—see page 66
Z8653134B	Hook mount kit
Z8653134B-01	Permanent mount kit
Z8653178A	Flat surface mount kit

### Note

- See page 67 for common replacement parts.

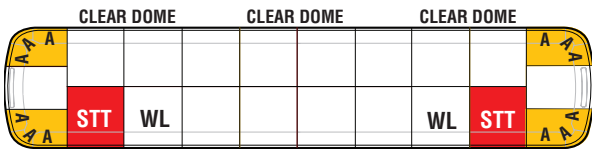

LPX53D-00001

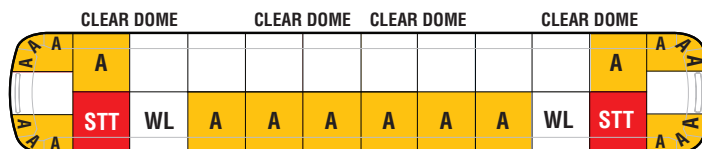

LPX61D-00005

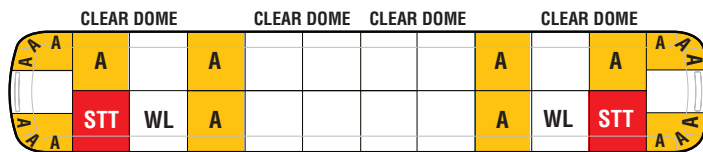

LPX61DNC-00001



*For additional lighting, center section upgrade kits with Solaris LED reflectors are available.*



*Federal Signal's ROC technology allows for field replacement of upgrade kits.*



# Legend® LPX



LPX45Z-00020

- Solaris® LED reflector technology
- ROC (Reliable Onboard Circuitry™) technology
- All-LED lightbar - LED takedowns, work lights and S/T/T lights available
- LEDs offered in Amber, Blue, Green, Red, and White
- Top domes offered in Amber, Blue, Clear, and Red
- Built-in SignalMaster, front/rear cut-off, intersection warning and “dimming” functions
- Same flash patterns, controller options and mounting option as standard Legend lightbars
- Available in 45", 53" and 61" lengths



Model	Description
	<b>LPX Serial Models</b>
	<b>45" Models - Flat mount and 6-button controller included</b>
LPX45Z-00019	Clear/Clear, (4) Amber corner LED reflectors, (12) Amber 5" LED reflectors, (2) Amber 2" LED reflectors
LPX45Z-00020	Clear/Clear, (4) Amber corner LED reflectors, (8) Amber 5" LED reflectors, (2) Amber 2" LED reflectors, (2) LED takedowns, (2) LED work lights
	<b>53" Models - Flat mount and 6-button controller included</b>
LPX53Z-00037	Clear/Clear/Clear, (4) Amber corner LED reflectors, (12) Amber 5" LED reflectors, (4) Amber 4" LED reflectors, (2) Amber 2" LED reflectors
LPX53Z-00038	Clear/Clear/Clear, (4) Amber corner LED reflectors, (8) Amber 5" LED reflectors, (4) Amber 4" LED reflectors, (2) Amber 2" LED reflectors, (2) LED work lights, (2) LED takedowns
	<b>61" Models - Flat mount and 6-button controller included</b>
LPX61Z-00007	Clear/Clear/Clear/Clear, (4) Amber corner LED reflectors, (12) Amber 5" LED reflectors, (8) Amber 4" LED reflectors, (2) Amber 2" LED reflectors
LPX61Z-00008	Clear/Clear/Clear/Clear, (4) Amber corner LED reflectors, (8) Amber 5" LED reflectors, (8) Amber 4" LED reflectors, (2) Amber 2" LED reflectors, (2) LED work lights, (2) LED S/T/T lights

### Accessories and Kits

660000	6-button programmable controller, light control only
660300	3-button programmable controller, light control only
660100	RS485 relay module
HKB-(Model)	Hook required with hook-on mount, specify vehicle—see page 66
Z8653134B	Hook mount kit
Z8653134B-01	Permanent mount kit
Z8653178A	Flat surface mount kit

### Note

- See page 67 for common replacement parts.

### How to Order

Choose one of the popular models above, customize your own lightbar with our online configurator or contact a local Federal Signal representative or distributor.

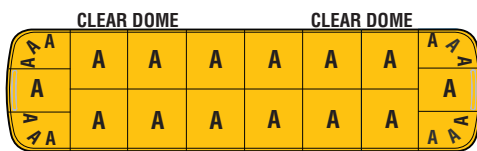

LPX45Z-00019

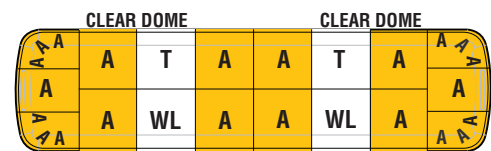

LPX45Z-00020

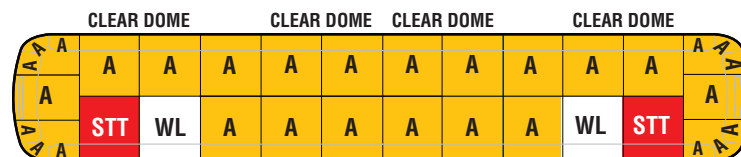

LPX61Z-00008

## Legend®



- Low-profile, linear lightbar design offers front and rear cut-off and dimming features
- Patented ROC (Reliable Onboard Circuitry™) eliminates approximately 85% of the potential failure points in a typical lightbar
- Optimized Solaris® LED reflectors maximize warning lights at 360-degrees and 90-degrees off-axis
- Optional built-in SignalMaster™ directional warning
- Advanced microprocessor controller provides three modes of operation and a library of flash patterns
- Six-button wireless controller option available (lightbar control only)
- LED S/T/T (stop/turn/tail) available
- LED takedown and LED alley lights available
- LEDs offered in Amber, Blue, Green, Red, and White
- Top dome colors are offered in Amber, Blue, Clear, and Red
- Three-button or six-button serial controller available for light control only
- Five-year LED warranty



Model	Description
	<b>45" Models - Flat mount and 6-button controller included</b>
LGD45Y-00378	Amber/Amber, (4) Amber corner LED reflectors, (12) Amber 5" LED reflectors, (2) Amber 2" LED reflectors
	<b>53" Models - Flat mount and 6-button controller included</b>
LGD53Y-00249	Amber/Amber/Amber, (2) LED takedowns, (4) Amber corner LED reflectors, (10) Amber 5" LED reflectors, (4) Amber 4" LED reflectors, (2) Amber 2" LED reflectors
LGD53Y-00136	Amber/Amber/Amber, (4) Amber corner LED reflectors, (12) Amber 5" LED reflectors, (4) Amber 4" LED reflectors, (2) Amber 2" LED reflectors
	<b>61" Models - Flat mount and 6-button controller included</b>
LGD61Y-00085	Clear/Clear/Clear/Clear, (2) LED S/T/T lights, (2) LED work lights, (4) Amber corner LED reflectors, (8) Amber 5" LED reflectors, (8) Amber 4" LED reflectors, (2) Amber 2" LED reflectors
LGD61Y-00086	Clear/Clear/Clear/Clear, (2) LED S/T/T lights, (2) LED work lights, (4) Amber corner LED reflectors, (8) Amber 5" LED reflectors, (8) Amber 4" LED reflectors, (2) Amber 2" LED reflectors
LGD61Y-00087	Clear/Clear/Clear/Clear, (2) LED S/T/T lights, (2) LED work lights, (4) Amber corner LED reflectors, (4) Amber 5" LED reflectors, (4) Amber 4" LED reflectors
	<b>70" Models</b>
LGD70-00001	Clear/Clear/Clear/Clear/Clear, (2) LED S/T/T lights, (2) halogen work lights, (4) Amber corner LED reflectors, (8) Amber 5" LED reflectors, (12) Amber 4" LED reflectors, (2) Amber 2" LED reflectors, 6-button controller
LGD70-00005	Clear/Clear/Clear/Clear/Clear, (2) LED S/T/T lights, (2) halogen work lights, (4) Amber corner LED reflectors, (8) Amber 5" LED reflectors, (12) Amber 4" LED reflectors, (2) Amber 2" LED reflectors, interface module, permanent mount

### Accessories and Kits

660000	6-button programmable controller, light control only
660300	3-button programmable controller, light control only
660100	RS485 relay module
HKB-(Model)	Hook required with hook-on mount, specify vehicle—see page 66
Z8653134B	Hook mount kit
Z8653134B-01	Permanent mount kit
Z8653178A	Flat surface mount kit

### Note

- See page 67 for common replacement parts.

### How to Order

Choose one of the popular models above, customize your own lightbar with our online configurator or contact a local Federal Signal representative or distributor.

## Legend®

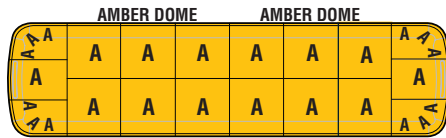

LGD45Y-00378

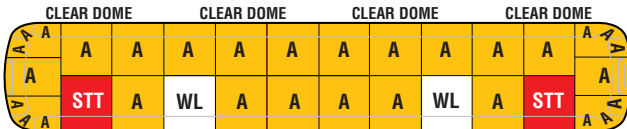

LGD61Y-00085

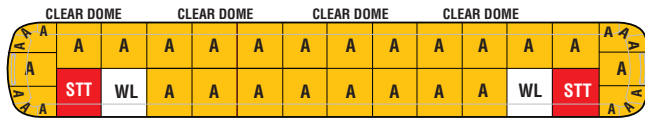

LDG70-00001

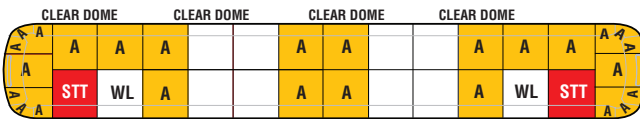

LDG70-00005

### ROC Solid Construction

Patented ROC (Reliable Onboard Circuitry™) technology eliminates 85% of potential failure points in the lightbar — reducing repair costs and increasing the hours your vehicle stays on the road.



### FS Convergence Network

Easy to install and service, the FS Convergence Network provides “plug-n-play” installation of Federal Signal serial lightbars to 3- and 6-button controllers. Systems can be expanded and customized by incorporating the Relay Module which allows users the capability of controlling four different devices with one unit (up to 40 Amps). This is ideal for users that would like to incorporate auxiliary lighting such as, but not limited to corner LEDs and wing lights.



### Solaris LED Reflector - The Best and Brightest in Lighting Technology

Our patented Federal Signal Solaris design features the latest in LED reflector technology for a bright and intense off-axis light output.



### 6-Button Wireless Controller Option

The Legend lightbars can now be configured with the 6-button wireless controller option. This latest technology offers secure communication between the lightbar and the controller. The only wiring required for installation is simple power and ground to the controller and lightbar which saves valuable time and money on installation.



# Valor™



- SpectraLux™ multicolor LED technology available in combinations of Amber, Blue, Red, and White
- Patented ROC (Reliable Onboard Circuitry™) technology
- Solaris® LED reflector technology for better optical efficiency options for lighting up work zones
- Six-button controller for ease of installation and lightbar control
- Available in 44" and 51" lengths



Model	Description
<b>44" Model - Permanent mount and 6-button controller included</b>	
VALR44S-AMBR1	44", (24) Amber reflectors, SignalMaster, 6-button controller
VALR44S-AMBR2	44", (14) Amber/White reflectors, (10) Amber reflectors, SignalMaster, front flood feature, 6-button controller
VALR44S-AMBR3	44", (22) Amber/White reflectors, (2) Amber reflectors, SignalMaster, full flood feature, 6-button controller
VALR44S-AMBR4	44", (24) Amber/White reflectors, SignalMaster, full flood feature, 6-button controller
<b>51" Model - Permanent mount and 6-button controller included</b>	
VALR51S-AMBR1	51", (28) Amber LED reflectors, hook mount, 6-button controller
VALR51S-AMBR2	51", (12) Amber modules, (16) Amber/White LED reflectors, hook mount, 6-button controller
VALR51S-AMBR3	51", (2) Amber modules, (26) Amber/White LED reflectors, hook mount, 6-button controller
VALR51S-AMBR4	51", (28) Amber/White modules, hook mount, 6-button controller

### Accessories and Kits

HKB-(Model)	Hook required with hook-on mount, specify vehicle — see page 66
LPO-HOOK	Kit, Hook on foot (require use of hook kit)
LPO-PERM	Kit, permanent mount

### Note

- See page 67 for common replacement parts.

### How to Order

Choose one of the popular models above, customize your own lightbar with our online configurator or contact a local Federal Signal representative or distributor.

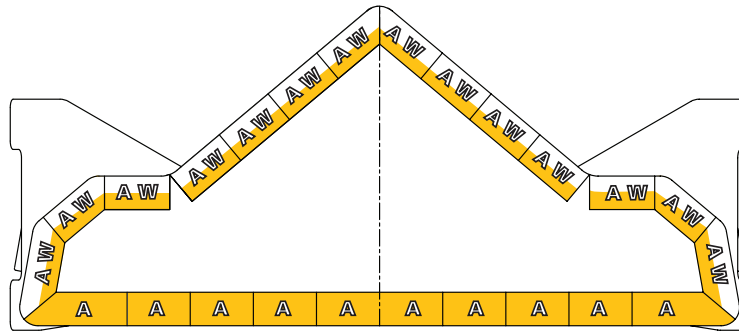

VALR44S-AMBR2

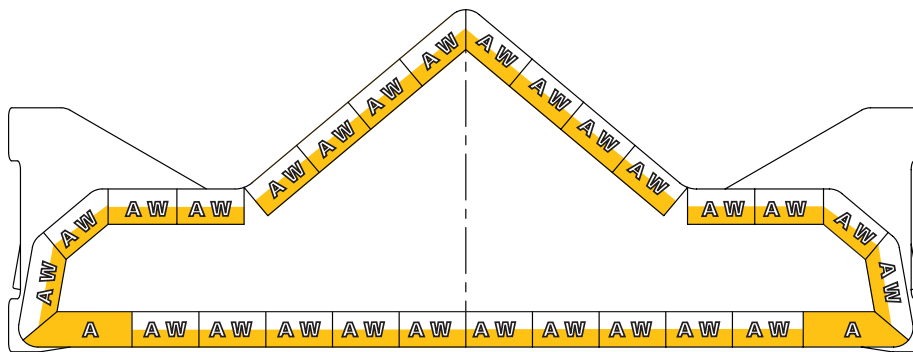

VALR51S-AMBR3

# Valor™

## SpectraLux™ Multicolor LED Technology

Exclusive to Federal Signal, SpectraLux provides the ability for a LED light head to operate with an amber flash pattern or the same module can be utilized as a work light.



## Solaris® LED Reflector Design

Federal Signal's Solaris® LED reflector technology is engineered to significantly increase off-axis warning and maximize the LED light source to eliminate dark spots and distribute 360-degrees of light coverage.



## ROC (Reliable Onboard Circuitry™) Technology

Federal Signal's patented ROC technology is manufactured to eliminate approximately 85% of the connection failure points found in a typical lightbar assembly. Wires, connections, and assemblies have been replaced by PCB assemblies — reducing labor repair time and increasing the road time for your work trucks.

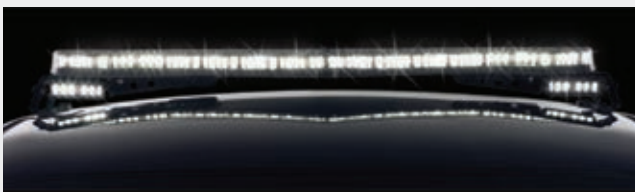

## Flood Light Capability

At a steady position, in all white mode, SpectraLux provides an impressive flood light to quickly illuminate a work zone scene.



## SignalMaster™

The Valor is built with an 8-head LED SignalMaster™ capability for directional warning.

## Simple Installation

For maximum performance, the FS Convergence Network provides literal 'plug-n-play' installation. Utilizing standard RJ45 connections, the Valor can be easily programmed using a six-button controller.



A serial interface module with your existing light controller can also be used to program and operate the features and functions of the Valor.



## Easy Service

Valor can be serviced while on the roof top. Remove the single dome and easily disconnect the ROC board.

## Low Power Feature

When activated, the low power feature significantly reduces the light output intensity.

## Clear Domes

For a sleek and stealthy appearance the Valor is available with Clear domes only.

## Available LED Colors

Single-color options are available in Red, Amber, Blue, White or Green

## Number of LEDs

In the 44-inch lightbar, if all positions are single-color:  
 Main bar: 24 heads x 6 LEDs each = 144 LEDs  
 In the 51-inch lightbar, if all positions are single-color:  
 Main bar: 28 heads x 6 LEDs each = 168 LEDs

## Current Draw

Without HotFoot lights - 24 amp - STEADY (44-inch)  
 - 28 amp - STEADY (51-inch)

# JetSolaris™

- Classic aerodynamic profile provides outstanding warning and limits drag
- Utilizes innovative patented ROC (Reliable Onboard Circuitry™) technology
- All models feature Solaris. LED reflector technology
- Integrated SignalMaster™ directional warning
- Twenty-six user-selectable patterns
- LEDs offered in Amber, Blue, Green, Red, and White
- Available in 21", 48", 54", 60" and 72" lengths
- Five-year LED warranty



CLASS 1 Online Lightbar Configurator ROC SOLARIS

Model	Description
	<b>48" Model - Mount kit included</b>
JLX4816-HD	Amber/Clear/Amber, (14) Amber 6-LED reflectors, (6) Amber 3-LED reflectors
	<b>60" Models - Mount kit included</b>
JLX6003-HD	Amber/Amber/Amber/Amber/Amber, (8) Amber 6-LED reflectors, (2) Amber 3-LED reflectors, work lights, LED S/T/T lights
JLX6003C-HD	Clear/Clear/Clear/Clear/Clear, (8) Amber 6-LED reflectors, (2) Amber 3-LED reflectors, work lights, LED S/T/T lights
JLX6004-HD	Amber/Amber/Amber/Amber/Amber, (4) Amber 6-LED reflectors, (2) Amber 3-LED reflectors, work lights, LED S/T/T lights
JLX6004C-HD	Clear/Clear/Clear/Clear/Clear, (4) Amber 6-LED reflectors, (2) Amber 3-LED reflectors, work lights, LED S/T/T lights
JLX6005-HD	Amber/Amber/Amber/Amber/Amber, (11) Amber 6-LED reflectors, (2) Amber 3-LED reflectors, LED S/T/T lights, SignalMaster feature
JLX6005C-HD	Clear/Clear/Clear/Clear/Clear, (11) Amber 6-LED reflectors, (2) Amber 3-LED reflectors, LED S/T/T lights, SignalMaster feature
JLX6007-HD	Amber/Amber/Amber/Amber/Amber, (11) Amber 6-LED reflectors, (2) Amber 3-LED reflectors, LED S/T/T lights, SignalMaster feature, front-light cutoff
JLX6007C-HD	Clear/Clear/Clear/Clear/Clear, (11) Amber 6-LED reflectors, (2) Amber 3-LED reflectors, LED S/T/T lights, SignalMaster feature, front-light cutoff
	<b>72" Model - Mount kit included</b>
JLX72LLL-00003	Clear/Clear/Clear/Clear/Clear/Clear/Clear, (18) Amber 6-LED reflectors, (4) Amber, 3-LED reflectors, LED S/T/T lights, work lights

### Accessories and Kits

HKB-(Model)	Hook required with hook-on mount, specify vehicle—see page 66
JNHK	Kit, hook mount brackets, Jet
UNPK	Kit, permanent mount, universal
501430	Kit, flat mount

### Note

- See page 67 for common replacement parts.

### How to Order

Choose one of the popular models above, customize your own lightbar with our online configurator or contact a local Federal Signal representative or distributor.

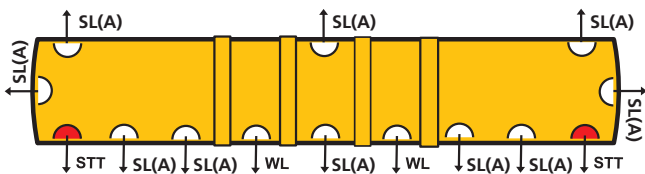

JLX6003-HD (Amber domes)  
JLX6003C-HD (Clear domes)

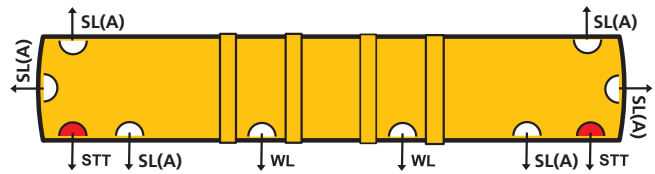

JLX6004-HD (Amber domes)  
JLX6004C-HD (Clear domes)

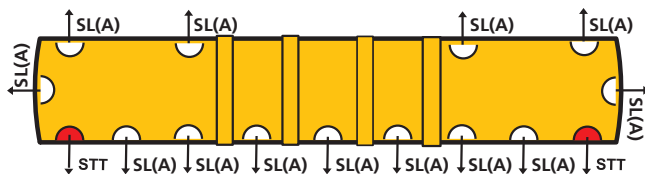

JLX6005-HD (Amber domes)  
JLX6005C-HD (Clear domes)

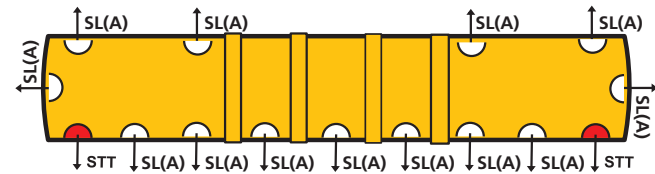

JLX6007-HD (Amber domes)  
JLX6007C-HD (Clear domes)

# JetStream® LED

- Classic aerodynamic profile provides outstanding warning and limits drag
- Ten user-selectable flash patterns
- Mode function allows switching between primary and secondary flash patterns
- Allows for upgrade of additional LED modules
- "T-slot/hardware entry hole" for ease of installation
- Five-year LED product warranty



JLL6003-CSB

CLASS 1

Model	Description
<b>54" Models - Flat mount included</b>	
JLL5402-SB	Amber/Amber/Amber/Amber, (22) Amber LED modules
JLL5402-CSB	Clear/Clear/Clear/Clear, (22) Amber LED modules
JLL5403-SB	Amber/Amber/Amber/Amber, (12) Amber LED modules, (2) work lights, (2) LED S/T/T lights
JLL5403-CSB	Clear/Clear/Clear/Clear, (12) Amber LED modules, (2) work lights, (2) LED S/T/T lights
<b>60" Model - Flat mount included</b>	
JLL6003-CSB	Clear/Clear/Clear/Clear/Clear, (12) Amber LED modules, (2) work lights, (2) LED S/T/T lights

### Accessories and Kits

HKB-(Model)	Hook required with hook-on mount, specify vehicle—see page 66
JN HK	Kit, hook mount brackets, Jet
UNPK	Kit, permanent mount, universal
521545	Kit, LED module, Clear/Amber
501430	Kit, flat mount

### Note

- See page 67 for common replacement parts.



JLL5403-CSB

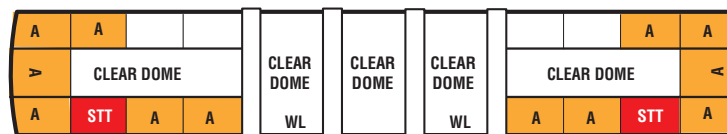

JLL6003-CSB

# JetStream™

- Classic aerodynamic profile provides outstanding warning and limits drag
- Powerful 70,000-candela halogen rotators
- "T-slot/hardware entry hole" for ease of installation
- Five-year rotator warranty



CLASS 1 CAC Title 13

Model	Description
	<b>48" Model - Flat mount kit included</b>
521142	Clear/Amber/Clear, (2) 95 FPM rotators, (2) 175 FPM rotators, (2) mirrors
521152	Amber/Amber/Amber, (2) 95 FPM rotators, (1) 175 FPM rotator, (4) V-mirrors
	<b>54" Model - Flat mount kit included</b>
527112	Clear/Clear/Clear/Clear, (2) 175 FPM rotators, (2) V-mirrors, (2) front flashers, (2) work lights, (2) S/T/T lights
	<b>60" Model - Flat mount kit included</b>
521112	Clear/Amber/Amber/Amber/Clear, (2) 95 FPM rotators, (3) 175 FPM rotators, (4) V-mirrors
527122	Amber/Clear/Amber/Clear/Amber, (2) 95 FPM rotators, (1) 175 FPM rotator, (2) V-mirrors, (2) front flashers, (2) work lights, (2) S/T/T lights
527132	Clear/Clear/Clear/Clear/Clear, (2) 120 FPM rotators, (2) V-mirrors, (2) front flashers, (2) work lights, (2) S/T/T lights
527152	Clear/Clear/Amber/Clear/Clear, (2) 95 FPM rotators, (2) 175 FPM rotator, (2) V-mirrors, (2) front flashers (2) work lights, (2) S/T/T lights

### Accessories and Kits

HKB-(Model)	Hook required with hook-on mount, specify vehicle—see page 66
JNHK	Kit, hook mount brackets, Jet
UNPK	Kit, permanent mount, universal
501430	Kit, flat mount

### Note

- See page 67 for common replacement parts.

### How to Order

Choose one of the popular models above or customize your own lightbar by contacting a local Federal Signal representative or distributor. Do-it-yourself with the Specify All Options worksheet form JSL-WKS (JetStream) available at [www.fedsig.com](http://www.fedsig.com).

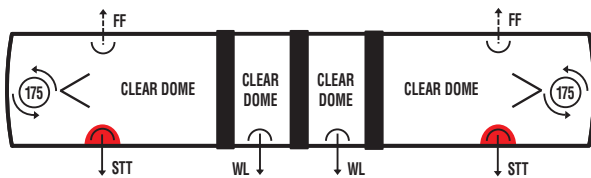

527112

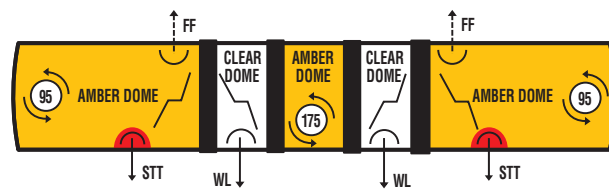

527122

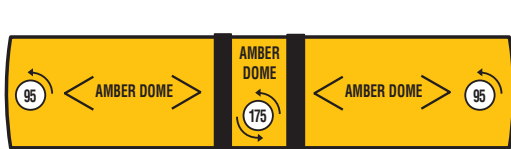

521152

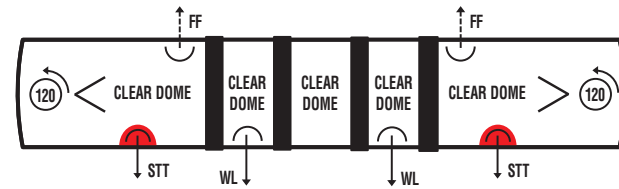

527132



# TurboBeam®

- Powerful 80,000-candela flash halogen rotators
- Optional diamond mirrors double flash rate
- Available in 35", 47" and 53" lengths
- The "Wrecker" model is available in 53" length
- Five-year rotator warranty



211916-02SB

CLASS 1

Model	Description
	<b>35", 12VDC, permanent mount</b>
211950-02SB	(2) 95 FPM rotators, (1) 175 FPM rotator, (2) diamond mirrors, Amber; -05(Clear)
211951-02SB	(3) 95 FPM rotators, (2) diamond mirrors, Amber
	<b>47", 12VDC, permanent mount</b>
211916-02SB	(4) 95 FPM rotators, (3) diamond mirrors, Amber; -03(Blue); -04(Red); -05(Clear); -252(Amber/Clear/Amber); -323(Blue/Amber/Blue); -452(Red/Clear/Amber); -453(Red/Clear/Blue); -454(Red/Clear/Red)
211920-02	(2) 95 FPM rotators, (2) 120 FPM rotators, (3) diamond mirrors, Amber
211922-02SB	(4) 175 FPM rotators, (3) diamond mirrors; -525(Clear/Amber/Clear)
211924-02	(2) 120 FPM rotators, (2) strobes, (3) diamond mirrors, Amber
	<b>53", 12VDC, permanent mount</b>
211917-02SB	"Wrecker" model, (4) 95 FPM rotators, (2) work lights, (2) S/T/T lights, (2) V-mirrors, Amber; -454(Red/Clear/Red)
211923-02	(4) 95 FPM rotators, (1) 120 FPM rotator, (2) diamond mirrors, Amber; -03(Blue); -04(Red)

### Common Replacement Parts

411167	Right end dome, Amber
411177	Center dome, Amber
411187	Left end dome, Amber
Z8440A265A-02	Halogen lamp, 55W, long life
AHRK	Rotator, 95 FPM
AHRK-F	Rotator, 175 FPM



211950-02SB

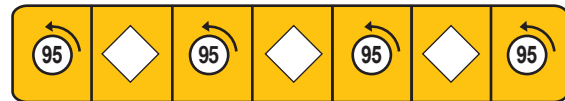

211916-02SB

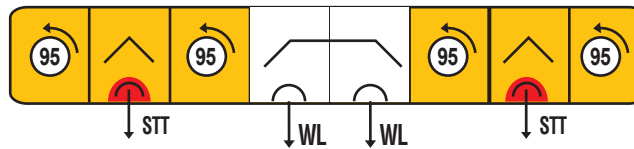

211917-02SB  
("Wrecker" model)

**For the most up-to-date hook mount information, contact Customer Support at 800-824-0254.**

CARS, VANS AND SUV'S			
MAKE/MODEL	YEAR	HOOK KIT MODEL #	ROOF WIDTH
<b>FORD</b>			
Crown Victoria	1992-11	HKB-CV92	46.0"
Edge	2012	HKB-FRD7	52.0"
Escape	2007-12	HKB-ESC7	49.5"
	2005-06	HKB-ESC5	49.0"
Expedition	2003-12	HKB-FTEX	52.0"
	2011-12	Permanent Mount	55.0"
Explorer	2008-10	HKB-XPL8	51.0"
	2000-06	HKB-WSTR	49.0"
Flex	2012	HKB-CHGR11	57.0"
Focus	2011-12	HKB-CHGR	48.0"
Fusion	2011-12	HKB-CHGR	48.5"
Mustang	2012	Permanent Mount	46.0"
Taurus	2011-12	HKB-TAR11	52.5"
	2009	HKB-TAR9	49.0"
Van	1987-11	HKB-SAV	65.0"
<b>CHEVROLET/GM</b>			
Caprice	2011	HKB-CAP11B	49.25"
Cruze	2012	HKB-MAG7	46.5"
Equinox LS (NO Roof Rails)	2012	HKB-IMP7	48.5"
	Express Van	2003-11	HKB-SAV
Impala	2006-12	HKB-IMP7	46.5"
	2012	HKB-CHGR11	48.0"
Malibu	2008-11	HKB-MAL8	47.0"
	2007	HKB-MAL7	44.0"
Suburban (NO Roof Rails)	2007-12	HKB-TA10	55.0"
	2000-06	HKB-CK2	52.0"
Tahoe	2007-12	HKB-TA010	55.0"
	2000-06	HKB-CK2	52.0"
Trail Blazer/Envoy	2007-10	HKB-CK2	51.0"
	2006	HKB-S10	48.0"
Traverse	2012	Permanent Mount	53.0"
Uplander	2007-08	HKB-UPL7	50.0"
Volt	2012	HKB-CHGR11	47.5"
<b>CHRYSLER/DODGE/JEEP</b>			
200	2012	HKB-FRD4	50.0"
Challenger	2012	Permanent Mount	54.5"
Charger	2011	HKB-CHGR11	50.25"
	2006-10	HKB-CHGR	47.0"
Commander	2010	HKB-CK2	56.0"
Durango	2008-09	HKB-DUR8	48.0"
Durango (Slick Top)	2011-12	HKB-MAL7	54.0"
	2004-07	HKB-CK2	48.0"
Durango (Roof Rack)	2005-07	HKB-DURR	48.0"
Grand Caravan/Town & Country	2008-12	HKB-CAR8	60.0"
	1996-07	HKB-CARV	48.5"
Grand Cherokee	2011	HKB-MAL7	54.0"
Liberty	2012	HKB-CAR8	55.0"
Wrangler	2012	Permanent Mount	N/A

All Federal Signal lightbars may be permanent or hook-on mounted. When using a hook-on mount, a separate hook kit is required for the make, model and year of your vehicle. Use the hook kit reference guide to find your vehicle's appropriate hook kit. Measurements for the roof width are determined by the style of the vehicle. These measurements may help you in choosing the lightbar length best suited for your vehicle.

**Permanent Mounting:** (no hook kit required)

**Vision and Vector** models use VMPK permanent mount kit.

**Vista** models use XPK permanent mount kit.

**JetStream, JetStrobe, AeroDync and all StreetHawk** lightbars use UNPK permanent mount kit.

**Hook-on Mounting:** (refer to hook kit reference guide)

**Vision and Vector** models use VM-SB mounting brackets plus hook kit.

**Vista** models use XHK-SC brackets plus hook kit.

**AeroDync and all StreetHawk** lightbars use UNHK mounting brackets plus hook kit.

**JetStream and JetStrobe** use JNHK mounting brackets plus hook kit.

TRUCKS				
MAKE MODEL	CAB STYLE	YEAR	HOOK KIT MODEL #	ROOF WIDTH
<b>FORD</b>				
F150	Reg	2009-10	HKB-FRD9	57.0"
		2007-08	HKB-FRD7	57.0"
		2004-06	HKB-FRD4	57.0"
		2009-11	HKB-FRD9	57.0"
	Ext/ SuperCab	2007-08	HKB-FRD7	57.0"
		2004-06	HKB-FRD4	57.0"
		2009-11	HKB-FRD9	57.0"
		2007-08	HKB-FRD7	57.0"
F250/350/450	Reg	2007-11	HKB-FHD7	58.5"
		2004-06	HKB-DKTA	58.5"
		2007-11	HKB-FHD7	58.5"
		2004-06	HKB-DKTA	58.5"
	Crew/ SuperCrew	2007-10	HKB-FHD7	58.5"
		2004-06	HKB-DKTA	56.5"
		2002-10	HKB-DKTA	48.5"
		2002-10	HKB-DKTA	48.5"
<b>CHEVROLET</b>				
Avalanche	Crew	2002-12	HKB-CK2	55.0"
Colorado/Canyon	Reg	2007-12	HKB-COL7	45.5"
		2004-06	HKB-COLO	45.0"
		2007-12	HKB-COL7	45.5"
		2004-06	HKB-COLO	45.0"
	Crew	2007-12	HKB-COL7	45.5"
		2004-06	HKB-COLO	45.0"
		2001-07	HKB-CK2	52.0"
		2001-07	HKB-CK2	52.0"
Silverado Classic/Sierra Classic (1500, 2500, 3500)	Reg	2007-12	HKB-TA07	55.0"
		2007-12	HKB-TA07	55.0"
	Crew	2007-12	HKB-TA07	55.0"
		2007-12	HKB-TA07	55.0"
<b>DODGE</b>				
Dakota	Club	2005-07	HKB-DKTA	45.5"
	Quad	2005-11	HKB-DKTA	45.5"
Ram (1500, 2500, 3500)	Reg	2010-12	HKB-FRD9	57.5"
		2003-05	HKB-RAM2	48.5"
	Quad	2010-12	HKB-FRD9	57.5"
		2003-07	HKB-RMQ4	51.0"
	Mega	2010-12	HKB-FRD9	57.5"
		2007	HKB-RMQ4	52.5"

**Notes**

The hook kit reference guide is updated on an ongoing basis as information becomes available. Please check the hook kit reference guide online at [www.fedsig.com](http://www.fedsig.com) for up-to-date vehicle and hook kit listings. For older vehicle make and model year hook kit offerings, please contact Customer Support at (800) 824-0254.

**Measurement of vehicles with standard roof**

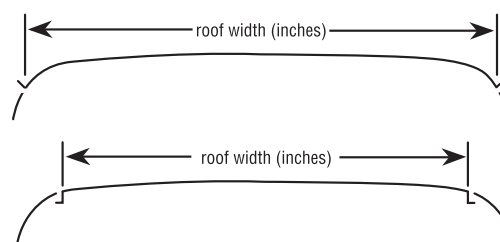

Model	Description
<b>Legend LPX and Legend</b>	
Z1751357A-02	RS485, 25-ft Interface cable assembly
Z1751364B	Cable, Interface, 36"
Z8107169A	Bulb, GH8, Bi-pin alley/takedown light, 50W halogen
Z8107241A	Bulb, alley light, 35W, 10-degrees spot, MR-11
Z8583020B-01	Gasket, dome, Clear, 6-ft required per base, sold by the foot
Z8583446D	Interface module with cable assembly
Z8583469D	Serial interface module
Z8653100A	Base, end, Clear
Z8653101A	Dome, end, Clear; -02(Amber); -03(Blue); -04(Red)
Z8653102A	Base, center, Clear
Z8653103A	Dome, center, Clear; -02(Amber); -03(Blue); -04(Red)
<b>Valor</b>	
Z1461855A-252	Harness, power/ground
Z1751575A-300	Cable, communication, external
Z2005639B	Controller replacement board
Z8651101A	Lens, 44" Valor
<b>JetSolaris/JetStream/JetStrobe</b>	
Z8107141A	Bulb, JetSolaris/JetStream/JetStrobe, traffic clearing light, 50W
Z8107A119A	Bulb, work lights
211673-95	Bulb, Stop/Turn/Tail
Z8548A028A	Bulb, flashing light
447532	Motor, 95 FPM, 12VDC
447542	Motor, 120 FPM, 12VDC
447539	Motor, 175 FPM, 12VDC
521502	Offset rotator with bulb, 95 FPM
521522	Offset rotator with bulb, 175 FPM
Z8552308A	Centered rotator with bulb, 95 FPM
Z8552308A-01	Centered rotator with bulb, 175 FPM
521592	Strobe tube and reflector assembly
Z8552427C-01	Four-head power supply
Z8552427C-02	Six-head power supply
Z8554057A	Flasher, 2-channel, hi-side
521500-02	End dome, Amber
521500-05	End dome, Clear
521501-02	Center dome, Amber
521501-05	Center dome, Clear
Z8552348A	Bulkhead gasket assembly, JetStream, Black; -02(Amber); -05(Clear)

Model	Page	Model	Page	Model	Page	Model	Page	Model	Page
210050	15	210895	24	320792	32	413202	43	448330	13
210298	51	210923	15	320793	32	413210	43	448410	29
210299	51	210928	15	320842	32	413216	43	448514	5
210330	50	210939	15	320862	32	413230	43	448522	5
210331	50	210961	53	320866	32	413241	43	448524	5
210333	50	210962	53	320882	32	413251	43	448572	5
210335	50	210982	15	320886	32	413300	43	452340	6
210341	50	211676	27	320892	32	413310	43	452341	6
210344	51	250520	18	320893	32	413316	43	452342	6
210345	51	250530	18	321102	33	413330	43	454217	6
210350	50	251500	18	321112	33	413340	43	454218	6
210358	51	251501	18	321702	32	413350	43	454219	53
210361	51	305101	45	321712	32	413410	43	462400	28
210363	51	305102	45	321722	32	413416	43	462510	28
210365	51	305103	45	322112	33	413430	43	462520	28
210376	25	305104	45	322122	33	415205	43	462530	28
210377	24	305107	45	322132	33	415207	43	462540	28
210387	25	305111	45	322502	33	416104	43	501430	9
210502	50	305112	45	322612	33	416106	43	510450	10
210504	50	320142	33	323142	33	416108	43	521112	64
210505	50	320162	33	323552	49	416109	43	521142	64
210539	27	320172	33	325039	49	416111	43	521152	64
210620	54	320182	33	325045	49	416118	43	521502	67
210624	54	320192	33	325046	49	416120	43	521522	67
210633	54	320310	34	325048	49	416126	43	521545	63
210728	27	320320	34	325541	49	416127	43	521592	67
210781	15	320330	34	325542	49	416128	43	527112	64
210782	20	320340	34	329000	46	416129	43	527122	64
210830	15	320350	34	329001	46	416139	43	527132	64
210831	15	320400	33	330302	33	416140	43	527152	64
210837	15	320401	33	330312	32	416205	42	605500	44
210838	15	320404	33	330501	40	442512	30	607109	44
210846	15	320406	33	330502	40	442522	30	607137	44
210850	27	320408	33	330503	40	442524	30	607145	44
210862	27	320602	33	330504	40	447302	30	620102	48
210877	15	320612	33	330505	40	447303	30	620104	48
210878	20	320742	32	330507	35	447532	5	620122	48
210881	27	320752	32	360800	49	447534	5	620142	48
210883	6	320762	32	360900	49	447539	5	620152	48
210890	14	320766	32	411167	65	447542	5	620202	48
210891	14	320772	32	411177	65	447544	5	620502	48
210893	14	320782	32	411187	65	448310	18	620504	48
210894	14	320786	32	413201	43	448320	18	620510	48

Model	Page	Model	Page	Model	Page	Model	Page	Model	Page
650201	53	208668-95	14	211914-02SC	10	329000-22	46	416200-33	42
650202	53	208669-95	6	211916-02SB	65	329000-25	46	416200-44	42
650205	9	210238-S	50	211917-02SB	65	329000-52	46	416200-55	42
660000	7	210238-W	50	211920-02	65	329001-22	46	416201-02	42
660100	7	210239-S	50	211922-02SB	65	329001-25	46	416201-03	42
660300	7	210239-W	50	211923-02	65	329001-52	46	416201-04	42
670132	54	210240-S	50	211924-02	65	330104-SB	34	416201-05	42
671512	54	210240-W	50	211925-02	24	331105-SB	34	420200-02	22
671522	54	210386B	10	211950-02SB	65	350172-02	35	420205-02	22
200030-95	22	210873-02	27	211951-02SB	65	350172-25	35	420208-02	22
200053-95	51	210880-01	30	212356-02	27	360401-02	40	420212-02	22
200069-95	24	210897B	10	212650-02	14	360401-03	40	420213-02	22
2005035A-95	24	210960-46	53	212650-03	14	360401-04	40	420222-02	15
2005082B-12-95	24	210960-54	53	212650-04	14	360411-02	40	420223-02	15
2005082B-23-95	25	210960-65	53	212650-25	14	360411-03	40	420400-02	21
2005082B-95	24	211007-95	21	212660-02	14	360411-04	40	420406-02	21
2005143B-95	27	211024-95	21	212660-25	14	360411-05	40	420412-02	21
2005191A-95	26	211090-95	22	220100-02	27	412010-02	22	430344-95	22
200523-95	27	211200-95	22	220105-02	27	412013-02	22	438694-95	15
200765-95	15	211300-95	27	220110-02	27	412027-02	22	439231-95	5
200766-95	22	211356-95	27	220200-02	27	412028-02	22	439290-95	24
200767-95	15	211360-95	27	220208-02	27	412046-02	21	439411-95	25
200768-95	15	211400-95	21	220300-02	26	412047-02	21	442112-02	30
200769-95	22	211550-95	27	220301-02	26	412048-02	21	442114-02	30
200771-95	21	211673-95	67	220308-02	26	413124	43	443112-02	30
200772-95	21	211680-02	25	220309-02	26	413201-05	43	443113-02	30
200773-95	21	211681-02	24	250121-02	18	413222B	43	443114-02	30
200775-95	21	211684-02	24	250141-02	18	413300-05	43	443212-02	30
200776-95	20	211694-02	24	250721-02	18	413322B	43	443312-02	30
205003-95	15	211695-02	24	250741-02	18	413422B	43	443314-02	30
205004-95	15	211740-02	20	251121-02	18	415010-02SC	10	443612-02	30
205580-95	27	211742-02	20	251141-02	18	415011-02SC	10	443712-02	30
205581-95	27	211749-02	20	252600-02	18	415111-02SC	10	448112-02	29
205582-95	27	211754-02	20	252601-02	18	415510-02SB	10	448114-02	29
205584-95	27	211778-02	16	252650-02SB	13	415611-02SB	10	448122-02	29
208505-95	27	211779-02	17	252651-02SB	13	416110B	43	448142-02	29
208551-95	15	211780-02	16	252654-04SB	13	416119B	43	448144-02	29
208566-95	25	211781-02	17	252655-04SB	13	416125B	43	448500-02	29
208567-95	25	211789-02	21	252657-02SB	13	416129-25	43	448500-05	48
208568-95	25	211820-02	24	262650-02	12	416132B	43	449112-02	29
208569-95	25	211823-02	25	272650-02	12	416133-25	43	449122-02	29
208666-95	14	211900-02SC	10	311682-02	25	416133-45	43	449142-02	29
208667-95	14	211906-02SC	10	322512-02	33	416200-22	42	450112-02	5



Model	Page
450114-02	5
450142-02	5
450144-02	5
450152-02	5
450162-02	5
451112-02	5
451412-02	5
452112-02	5
452142-02	5
452162-02	5
452412-02	5
452510-02	5
452642-02	5
452643-02	5
453000-02SB	6
453001-02SB	6
453002-02SB	6
453003-02SB	6
453200-02	6
453201-02	6
453202-02	6
454200-02SC	4
454200-03SC	4
454200-04SC	4
454200-05SC	4
454200-06SC	4
454200-24-02SC	4
454200-24-25SC	4
454200-25SC	4
454200-35SC	4
454200-45SC	4
454200-65SC	4
454201-02SC	4
454201-03SC	4
454201-04SC	4
454201-05SC	4
454201-06SC	4
454201-24-02SC	4
454201-24-25SC	4
454201-25SC	4
454201-35SC	4
454201-45SC	4
454201-65SC	4

Model	Page
454202-02SC	4
454202-03SC	4
454202-04SC	4
454202-05SC	4
454202-06SC	4
454202-24-02SC	4
454202-24-25SC	4
454202-25SC	4
454202-35SC	4
454202-45SC	4
454202-65SC	4
454204-02SC	5
454204-25SC	5
454205-02SC	5
454205-25SC	5
454206-02SC	5
454206-25SC	5
454300C-AB	4
454300C-AR	4
454300C-AW	4
454300C-BA	4
454300C-BR	4
454300C-RA	4
454300C-RB	4
454300C-RW	4
454300CS-BWB	4
454300CS-RWR	4
454301C-AA	4
454301C-AB	4
454301C-AR	4
454301C-BR	4
454301C-BW	4
454301C-RA	4
454301C-RB	4
454301C-RW	4
454301CS-00005	4
454302C-AR	4
454302C-BA	4
454302C-BR	4
454302C-BW	4
454302C-RA	4
454302C-RB	4
454302C-RW	4

Model	Page
462121-02	28
462141-02	28
462500-02	28
521500-02	67
521500-05	67
521501-02	67
521501-05	67
602111-02/03/04	55
602111-05	55
605501-02	44
605510	44
605520	44
605523-02	44
607100-04	44
607101-02	44
607101-03	44
607102-02	44
607103-04	44
607105-04	44
607106-02	44
607110	44
607111	44
607112-02	44
607112-03	44
607120-02	44
607123-02	44
607123-03	44
607124-05	44
607125-05	44
607126-02	44
607127-02	44
607128-02	44
607129-02	44
607130-02	44
607131-02	44
607133-02	44
607133-25	44
607134-02	44
607134-25	44
607139-02	44
607140-02	44
607141-04	44
607141-05	44

Model	Page
607142-04	44
620200	48
620201	48
650205	45
750000-T1	54
8107230A-95	26
AHRK	65
AHRK-F	65
CAMADP-EXT	52
CAMADP-INT-2	52
CAMADP-INT-4	52
CAMADP-RCA-IN	52
CAMADP-RCA-OUT	52
CAMADP-Y-2	52
CAMBRK-HD	52
CAMCABLE-10	52
CAMCABLE-15	52
CAMCABLE-20	52
CAMCABLE-40	52
CAMCABLE-5	52
CAMCABLE-SHORT	52
CAMCABLE-TRK	52
CAMCCD-BALLNTSC	52
CAMCCD-DOMENTSC	52
CAMCCD-FLS2NTSC	52
CAMCCD-FLSHNTSC	52
CAMCCD-REARNTSC	52
CAMCCD-SIDENTSC	52
CAMDVR-4-B	52
CAMDVR-SD	52
CAMLCD-70	52
CAMLCD-BRACKET	52
CAMLCD-INT-56	52
CAMLCD-INT-70-B	52
CAMLCD-INT-MIR	52
CAMSET56-NTSC-2	52
CAMSET70-NTSC4B	52
DCK	5
FA3-SC	53

Model	Page
FB3C	46
FB3MEF	46
FB3MEF-RHDMC	46
FHL2-SC	53
FHL-HL	53
FHL-TAIL	53
GHFLANGE	49
GHSCENE	49
GL1-A	45
GL1-B	45
GL1-R	45
GL2-A	45
GL2-B	45
GL2-R	45
HKB-(Model)	56
IPX300-2	37
IPX300-3	37
IPX300-4	37
IPX300-5	37
IPX300-6	37
IPX302-2	37
IPX302-3	37
IPX302-4	37
IPX302-6	37
IPX310-2	37
IPX310-3	37
IPX310-4	37
IPX310-5	37
IPX310-6	37
IPX312-2	37
IPX312-3	37
IPX312-4	37
IPX312-6	37
IPX600-A	36
IPX600-B	36
IPX600-G	36
IPX600-R	36
IPX600-W	36
IPX602-A	36
IPX602-B	36
IPX602-R	36
IPX603-A	36
IPX603-B	36

Model	Page	Model	Page	Model	Page	Model	Page	Model	Page
IPX603-G	36	JLX4816-HD	62	LPX61DNC-00001	56	QL64Z3H-RIGHT	41	QL97SFC-GG	42
IPX603-R	36	JLX6003C-HD	62	LPX61Z-00007	57	QL64Z3V	41	QL97SFC-RA	42
IPX603-W	36	JLX6003-HD	62	LPX61Z-00008	57	QL64Z3V-LED	41	QL97SFC-RB	42
IPX604-A	36	JLX6004C-HD	62	ME4QL-A	9	QL64Z3V-LEFT	41	QL97SFC-RC	42
IPX604-B	36	JLX6004-HD	62	ME4QLC-A	9	QL64Z3V-RIGHT	41	QL97SFC-RG	42
IPX604-R	36	JLX6005C-HD	62	MPS300-A	39	QL64Z4V	41	QL97SFC-RR	42
IPX620-BA	36	JLX6005-HD	62	MPS300-B	39	QL64Z4V-LED	41	QL97SF-GG	42
IPX620-BR	36	JLX6007C-HD	62	MPS300-R	39	QL64Z4V-LEFT	41	QL97SF-RR	42
IPX620-BW	36	JLX6007-HD	62	MPS300-W	39	QL64Z4V-RIGHT	41	QL97XF-(color)	42
IPX620-RA	36	JMMK	8	MPS350-A	39	QL64Z-ARROW	41	QL97XFC-(color)	42
IPX620-RW	36	JMPK	8	MPS350-B	39	QL64Z-BACKUP	41	QL97XFC-C	42
IPX620-WA	36	JNHK	62	MPS350-R	39	QL64Z-BTT	41	QL97XFC-G	42
IPX6M-1	36	LF12ES-LED	47	MPS350-W	39	QL64Z-TURN	41	QL97XF-G	42
IPX-GRL1	38	LF12TR	47	MPS600-AA	39	QL73MB	41	SMELED-PLS-6	33
IPX-GRL2	38	LF18ES-LED	47	MPS600-BB	39	QL73MC	41	SMELED-PLS-8	33
IPX-GRL3	38	LF18TR	47	MPS600-RB	39	QL73SF-AA	41	SPL2	5
IPX-GRL4	38	LFHK	47	MPS600-RR	39	QL73SF-BB	41	SW1	54
IPX-LPF1	38	LGD12-00001	9	MPS600-RW	39	QL73SFC-AC	41	SW2	4
IPX-LPH1	38	LGD12-00002	9	MPS600-WW	39	QL73SFC-BA	41	SW200-012	54
IPX-LPV1	38	LGD24-00001	7	MPS650-AA	39	QL73SFC-RA	41	SW200-BK1	54
IPX-LPVX1	38	LGD24-00018	7	MPS650-BB	39	QL73SFC-RB	41	SW30	54
IPXM-1	37	LGD24-00026	7	MPS650-RB	39	QL73SFC-RC	41	SW300-012	54
IPX-PB45H	38	LGD24-00035	7	MPS650-RR	39	QL73SFC-RG	41	SW300-BK	54
IPX-PB45V	38	LGD24-00036	7	MPS650-RW	39	QL73SFC-RR	41	SW400SS	54
IPX-PBL1	38	LGD24-00046	7	MPS650-WW	39	QL73SF-GG	41	SW-BK	54
IPX-RDW2	38	LGD24-00047	7	QL64MB	41	QL73SF-RR	41	SW-BK1	54
IPX-ROW1	38	LGD24-00048	7	QL64MC	41	QL73XF-(color)	41	UF7	46
IPX-RSW1	38	LGD24-00107	7	QL64MHL	41	QL73XFC-(color)	41	UNHK	53
IPX-RSW2	38	LGD45Y-00378	58	QL64SF-AA	41	QL73XFC-C	41	UNPK	62
IPX-SW1	38	LGD53Y-00136	58	QL64SF-BB	41	QL73XFC-G	41	VALR44S-AMBR1	60
IPX-TRNK1	38	LGD53Y-00249	58	QL64SFC-(Color/ Color)	41	QL73XF-G	41	VALR44S-AMBR2	60
IPX-TRNK2	38	LGD61Y-00085	58	QL64SF-GG	41	QL97HSCENE	42	VALR44S-AMBR3	60
IPX-TRNK3	38	LGD61Y-00086	58	QL64SF-RR	41	QL97LEDSCENE	42	VALR44S-AMBR4	60
JLL5402-CSB	63	LGD61Y-00087	58	QL64XF-(color)	41	QL97MB	42	VALR51S-AMBR1	60
JLL5402-SB	63	LGD70-00001	58	QL64XF-C	41	QL97MC	42	VALR51S-AMBR2	60
JLL5403-CSB	63	LGD70-00005	58	QL64XFC-(color)	41	QL97SF-AA	42	VALR51S-AMBR3	60
JLL5403-SB	63	LPO-HOOK	60	QL64XFC-G	41	QL97SF-BB	42	VALR51S-AMBR4	60
JLL6003-CSB	63	LPO-PERM	60	QL64XFC-G	41	QL97SFC-AA	42	VPX800-2	35
JLX2101C-HD	8	LPX45Z-00019	57	QL64XF-G	41	QL97SFC-AC	42	VPX800-3	35
JLX2101-HD	8	LPX53D-00001	56	QL64Z3H	41	QL97SFC-BA	42	VPX800-4	35
JLX2106C-HD	8	LPX53Z-00037	57	QL64Z3H-LEDLEFT	41	QL97SFC-BB	42	VPX800-5	35
JLX2106-HD	8	LPX53Z-00038	57	QL64Z3H-LEDRIGHT	41	QL97SFC-BC	42	VPX800-6	35
JLX2192-HD	8	LPX61D-00005	56	QL64Z3H-LEFT	41	QL97SFC-CC	42	VPX802-2	35



Model	Page	Model	Page	Model	Page	Model	Page	Model	Page
VPX802-3	35	Z8003245A-02	9	Z8107A095A	55	Z8550269A	55	Z8575108A	49
VPX802-4	35	Z8003245A-08	9	Z8107A119A	67	Z8552308A	67	Z8575272A	18
VPX802-6	35	Z8012013B-01	41	Z8263073-05	26	Z8552308A-01	67	Z8583020B-01	67
VPXM-1	35	Z8012062C-02	42	Z8422528A	48	Z8552348A	67	Z8583052A	55
VPX-SW	38	Z8012075B	48	Z8422B399A-01	48	Z8552427C-01	67	Z8583292A	55
Z122283A	54	Z8012078A	41	Z8422C002-01	30	Z8552427C-02	67	Z8583446D	67
Z122374A	54	Z8012109A	41	Z8433008B-07	5	Z8554057A	67	Z8583469D	67
Z122385B	54	Z8012110A	41	Z8433039B	48	Z8559A055A	46	Z8613194A-01	32
Z124102A	54	Z8012111A	42	Z8433113A	48	Z8559A055A-01	46	Z8613194A-02	32
Z124161A	4	Z8107141A	67	Z8440A265A-02	65	Z8560081A	6	Z8613194A-03	32
Z124A058A	54	Z8107146C	55	Z8444313C	13	Z8560082A	6	Z8613194A-04	32
Z140325A-13	33	Z8107152A	55	Z8444372A	18	Z8560095B-02	4	Z8613194A-05	32
Z140325A-13	34	Z8107156A	55	Z8444373A-01	18	Z8560109A	4	Z8613194A-06	32
Z1461855A-252	67	Z8107158A	55	Z8444374A	13	Z8573001B	33	Z8651101A	67
Z146903B	48	Z8107165A	55	Z8444375A-01	13	Z8573007A	55	Z8653100A	67
Z1751357A-02	67	Z8107169A	67	Z8444397A	13	Z8573157B-01	33	Z8653101A	67
Z1751364B	67	Z8107170A	55	Z8444A151A	55	Z8573180A	33	Z8653102A	67
Z1751575A-300	67	Z8107232A	55	Z8548A028A	67	Z8573229A-02	32	Z8653103A	67
Z2005265B	21	Z8107241A	67	Z8550137A	46	Z8575067A	55	Z8653134B	7
Z2005639B	67	Z8107A027	55	Z8550250A	47	Z8575105A	49	Z8653134B-01	7
Z211800B	55	Z8107A033	55	Z8550251A	47	Z8575107A	49	Z8653178A	7



- (1) **AGREEMENT AND LIMITATIONS.** The agreement between Seller and Buyer (the "sales contract") with respect to the sale of goods (the "goods") described herein shall consist of the terms appearing herein with any additions or revisions of such terms mutually agreed to in writing by Seller and Buyer. Seller objects to and shall not be bound by any additional or different terms, whether printed or otherwise, in Buyer's purchase order or in any other communication from Buyer to Seller unless specifically agreed to by Seller in writing. Except as expressly stated in the sales contract, no reference to Buyer's purchase order or other communication from Buyer shall be deemed to incorporate by reference any terms appearing therein. The sales contract shall be for the benefit of Seller and Buyer and not for the benefit of any other person. Prior courses of dealing, trade usage and verbal agreements not reduced to a writing signed by Seller, to the extent they modify, add to, detract from, supplant or explain the sales contract, shall not be binding on Seller.
- (2) **TERMINATION OR MODIFICATION.** The sales contract may be modified or terminated only upon Seller's written consent except that stenographic and clerical errors are subject to correction by Seller or upon Seller's written consent. If Seller shall declare or consent to a termination of the sales contract, in whole or in part, Buyer, in the absence of contrary written agreement signed by Seller, shall pay termination charges based upon expenses and costs incurred in the production of the goods or in the performance of the services to the date such termination is accepted by Seller including, but not limited to, expenses of disposing of materials on hand or on order from suppliers and the losses resulting from such disposition, plus a reasonable profit. Notwithstanding the foregoing any goods substantially completed or services performed on or prior to such termination shall be accepted and paid for in full by Buyer.
- (3) **PRICE AND PAYMENT.** Prices are subject to increase by Seller based on Seller's prices in effect at the time of shipment in all instances where specified shipment date is later than 30 days from date of order. Unless otherwise specified in the sales contract or Seller's applicable price list, prices are F.O.B. Seller's point of shipment, and the terms of payment are NET 30 days from the date of invoice. If the sales contract is for more than one unit of goods, the goods may be shipped in a single lot or in several lots at the discretion of Seller. In such event each such shipment shall be paid separately and Buyer shall be responsible for all transportation charges. Seller may require full or partial payment or payment guarantee in advance of shipment whenever, in its opinion, the financial condition of Buyer so warrants. Payment by credit card may be subject to a service charge.
- (4) **PAST DUE INTEREST:** Amounts not paid when due shall be subject to past due interest at the rate of 18% per year or the highest rate permitted by law, whichever is less.
- (5) **RISK OF LOSS.** The risk of loss or the goods or any part thereof shall pass to the buyer upon delivery thereof by Seller to the carrier. Buyer shall have sole responsibility for processing and collection of any claim of loss against the carrier.
- (6) **TAXES.** Prices do not include taxes. Buyer shall pay Seller, in addition to the price of the goods, any applicable excise, sales, use or other tax (however designated) imposed upon the sale, production, delivery or use of the goods ordered to the extent required or not forbidden by law to be collected by Seller from Buyer, whether or not so collected at the time of the sale, unless valid exemption certificates acceptable to the taxing authorities are furnished to Seller before the date of invoice.
- (7) **DELIVERY.** Promises of delivery from stock are subject to prior sale. Delivery dates are not guaranteed but are estimated on the basis of immediate receipt by Seller of all information to be furnished by Buyer and the absence of delays, direct or indirect, resulting from or contributed to by circumstances beyond Seller's reasonable control. Seller shall in good faith endeavor to meet estimated delivery dates but shall not be liable to Buyer for any damages as a result of any delay caused or contributed to by circumstances beyond Seller's reasonable control.
- (8) **DEDUCTIONS AND RETURNS.** Please contact the factory before returning any merchandise. A Return Material Authorization (RMA) must be obtained before returning merchandise for credit. All returns are subject to inspection of merchandise and any defects in the units will be charged back to the Buyer at the cost of parts and labor. Credit deductions will not be honored unless covered by a credit memorandum. Goods shipped to the Buyer may be returned to Seller for credit only upon the Seller's prior written consent (such consent to be in the sole discretion of Seller) and upon terms specified by Seller, including prevailing restocking, freight, and handling charges. Buyer assumes all risk of loss for such returned goods until actual receipt thereof by Seller. Agents of Seller are not authorized to accept returned goods or to grant allowances or adjustments with respect to Buyer's account.
- (9) **INSPECTION.** Buyer shall inspect the goods immediately upon the receipt thereof. All claims for any alleged defect in Seller's performance under this sales contract, capable of discovery upon reasonable inspection, must be fully set forth in writing and received by Seller within thirty days of Buyer's receipt of the goods. Failure to make any such claim within said thirty-day period shall constitute a waiver of such claim and an irrevocable acceptance of the goods by Buyer.
- (10) **LIMITED WARRANTY.** Federal Signal Corporation, Mobile Systems, (Federal) warrants each new product, except speakers, to be free from defects in material and workmanship, under normal use and service, for a period of (3) years on parts replacement from the date of manufacture stamped on the product and (1) year on labor from the date of delivery to the first user-purchaser except for noted products. Speakers are warranted for a period of (2) years on parts replacement from the date of manufacture stamped on the product and (1) year on labor from the date of delivery to the first user-purchaser. The following products are warranted for (5) years on parts replacement from the date of manufacture stamped on the product and (1) year on labor from the date of delivery to the first user-purchaser: "Light Emitting Diode" (LED) products (Signaltech and SignalMaster Plus LED products not included), "Ricochet" strobe power supplies, "Unitrol" brand products, rotating light assemblies from all lightbars, all rotating beacons and mini-lightbars (Sentinel not included), all Phase II strobe beacon models, all 901 and 951 strobe beacon models, all 651 and 851 strobe beacon models, all US5, US6, and US7 UltraStar strobe beacon models, and all Arctic strobe beacon models. Strobe flashtubes are warranted for (1) one year parts replacement from the date of delivery of the first user-purchase. During this warranty period, the obligation of Federal is limited to repairing or replacing, as Federal may elect, any part or parts of such product which after examination by Federal, is found to be defective as the result of a defect in material and/or workmanship. Federal will provide warranty for any unit which is delivered, transported prepaid, to the Federal factory or designated authorized warranty service center for examination and such examination reveals a defect in material and/or workmanship. This warranty does not cover travel expenses, the cost of specialized equipment for gaining access to the product, or labor charges for removal and re-installation of the product. Domes & lenses, lamps or batteries are not covered under warranty. This warranty does not extend to any unit which has subjected to abuse, misuse, improper installation or which has been inadequately maintained, nor damage resulting from incompatible chemicals or cleaning material, nor to units which have problems relating to service or modification at any facility other than the Federal factory or authorized service centers. This warranty is in lieu of all other warranties, express or implied, including warranties of merchantability and fitness for a particular purpose.
- (11) **REMEDIES AND LIMITATIONS OF LIABILITY.** In the event Seller is claimed to have breached any of its obligations under the sales contract, whether of warranty or otherwise, Seller may repair any defective goods, request the return of the goods and tender, at Seller's option, a replacement shipment of goods or the purchase prices theretofore paid to Seller. Seller shall tender a refund of the purchase price at its option upon actual receipt of the goods by Seller. If Seller so requests the return of the goods, the goods will be redelivered to Seller, transportation prepaid, in accordance with Seller's instructions. The remedies contained in this and the preceding paragraph constitute the sole recourse against Seller for breach of any of Seller's obligations under the sales contract whether of warranty or otherwise. In no event shall Seller be liable for consequential damages nor shall Seller's liability on any claim for any direct, incidental, consequential or special damages arising out of or connected with the sales contract or the manufacture, sale, delivery or use of the goods exceed the purchase price of the goods. Seller shall not be liable for failure to perform its obligations under the sales contract, resulting directly or indirectly from or contributed to by acts of God; acts of Buyer; civil or military authority; priorities; fires; war; riot; delays in transportation; lack of or inability to obtain raw materials, components, labor, fuel or supplies; or other circumstances beyond Seller's reasonable control, whether similar or dissimilar to the foregoing.
- (12) **PATENTS.** Seller shall hold Buyer harmless, to the extent herein provided, against any rightful claim of any third person by way of infringement of any United States Letters patent by such goods as are of Seller's own manufacture, but if Buyer furnished specifications to Seller, Buyer shall hold Seller harmless against any such infringement claims which arise out of compliance with such specifications. Seller's agreement in this paragraph to hold Buyer harmless shall not apply to any infringement consisting of the use of goods manufactured by Seller as a part of any combination with goods manufactured by Buyer or others. In the event that any goods manufactured by Seller are in any suit held to constitute infringement and their use is enjoined, Seller, if unable within a reasonable time to secure for Buyer the right to continue using such goods, either by suspension of the injunction, by securing for Buyer a license, or otherwise, shall at its own expense, either replace such goods with non-infringing goods or modify such goods so that they become non-infringing, or accept the return of the enjoined goods and refund the purchase price theretofore paid by Buyer less allowance for any period of actual use thereof. Except as in this paragraph provided, Seller makes no warranty that the goods will be delivered free of the rightful claim of any third person by way of infringement or the like and Buyer's remedies will be limited to those provided in this paragraph.
- (13) **ASSIGNMENT AND DELEGATION.** No right or interest in this sales contract shall be assigned by Buyer without Seller's prior written consent, and no delegation of any obligation owed, or of the performance of any obligation, by Buyer shall be made without Seller's prior written consent. Any attempted assignment or delegation shall be void and totally ineffective for all purposes unless made in conformity with this paragraph 9, 10 and 11 hereof, and if effective shall be subject to all limitations of this sales contract.
- (14) **SEVERABILITY.** If any term, clause or provision contained in the sales contract is declared or held invalid by a court of competent jurisdiction, such declaration or holding shall not affect the validity of any other term, clause or provision herein contained.
- (15) **INSTALLATION.** Installation shall be by Buyer unless otherwise specifically stated on the sales contract.
- (16) **GOVERNING LAW AND LIMITATIONS.** The formation and performance of the sales contract shall be governed by the laws of the State of Illinois. Whenever a term defined by the Uniform Commercial Code as adopted in Illinois is used in these standard terms, the definition contained in said Uniform Commercial Code is to control. Any action for breach of the sales contract or any covenant or warranty contained herein must be commenced within one year after the cause of action accrued.



**ALBERTA /  
BRITISH COLUMBIA**

**MARSH FRANCHUK**

T. 780.721.2122

E. MARSH@PROFORCECANADA.CA

**MANITOBA /  
SASKATCHEWAN**

**CHUCK FRITSCH**

T. 204.291.2080

E. CHUCK@PROFORCECANADA.CA

**WESTERN CANADA /  
INSIDE SALES SUPPORT**

**RYAN FRITSCH**

T. 204.292.8370

E. RYAN@PROFORCECANADA.CA

**ONTARIO / MARITIMES**

**MARK BURNS**

T. 647.284.8667

E. MARK@PROFORCECANADA.CA

**ONTARIO**

**JONATHAN MOUNTAIN**

T. 647.274.3251

E. JONATHAN@PROFORCECANADA.CA

**NATIONAL ACCOUNTS /  
QUEBEC**

**YVES LAMOUREUX**

T. 514.893.5021

E. YVES@PROFORCECANADA.CA

**QUEBEC / SALES MANAGER**

**JEAN LABRIE**

T. 514.347.094

E. JEAN@PROFORCECANADA.CA

**WWW.PROFORCECANADA.CA**

*The information provided on these pages are for part# and picture reference only. If more technical information on any part, please refer to suppliers website or call your Pro Force representative listed in this brochure.*

Join Us:    
FederalSignalFR



**Federal Signal**

Main Office / Factory  
2645 Federal Signal Drive  
University Park, IL 60484  
Phone: (800) 824-0254  
Fax: (800) 787-6237

E-mail: [amberorders@fedsig.com](mailto:amberorders@fedsig.com)

**Customer Orders and Support Hours:**

7:00 a.m. - 4:30 p.m. CST  
Repair: (800) 433-9132  
Unitrol Repairs: (800) 854-3375

**[www.fedsig.com](http://www.fedsig.com)**

Opticom and Littlite are trademarks of their respective owners.  
All others indicated are trademarks of Federal Signal Corporation.

©2012 Federal Signal Corporation. All rights reserved worldwide. MC40000