



FOUNDATION AIR BRAKE PARTS



Table of Contents

FOUNDATION AIR BRAKE PARTS	1
SERVICE TOOLS	2
MISCELLANEOUS PRODUCTS	3
CROSS REFERENCE LISTING	4
NUMERICAL PARTS LISTING	5

Please e-mail any comments/suggestions/corrections to us at:
catalogfeedback@meritor.com

or mail to:
Meritor, Inc.
Attn: Catalog Department
7975 Dixie Highway
Florence, KY 41042

INDEX**Foundation Air Brake Parts****Page****Section 1.1**

Anchor Pin Felts.....	1-125
Anchor Pin Links.....	1-128
Anchor Pin Nuts.....	1-128
Anchor Pin Retainers	1-124
Anchor Pin Seals.....	1-125
Anchor Pin Spider Bushings.....	1-135
Anchor Pins	1-119
Brake Block Bolts.....	1-148
Brake Identification Charts	1-150
Brake Kit Identification Chart	1-70
Brake Repair Kits	1-73
Brake Shoe Bushings	1-133
Brake Shoe Hold Down Clips	1-130
Brake Shoes	1-153
Dust Cover	1-131
Dust Shields	1-160
Grease Fittings	1-135
Lock Rings	1-126
Retainer Springs	1-145
Return Spring Retainers... ..	1-147
Return Springs	1-137
Rivets	1-149
Roller Pins	1-118
Roller Retainers	1-129
Rollers	1-112
Screws	1-131
Spider Flange	1-160
Spiders	1-159
Washers	1-131
Wear Plates	1-119

Section 1.2

Camshaft Bushings	1-233
Camshaft E.S.P. Guide	1-167
Camshaft Introduction	1-165
Camshaft Lock Rings	1-252
Camshaft Repair Kits	1-205
Camshaft Seals	1-242
Camshaft Spider Bushing Kits.....	1-241
Camshaft Support Brackets	1-227
Camshaft Tube Enclosures	1-231
Camshaft Washers and Spacers	1-245
Camshafts	1-179

INDEX

Foundation Air Brake Parts (continued)**Page****Section 1.3**

Clevis Kits - Crewson	1-283
Clevis Kits - Meritor	1-260
Clevis Pin Bushing	1-257
Meritor Clearance Sensing ASA - Drive Axle	1-267
Meritor Clearance Sensing ASA - Steer Axle (Non-Drive)	1-267
Meritor Clearance Sensing ASA - Trailer Axle Appl. for 12-1/4" Brakes	1-268
Meritor Clearance Sensing ASA - Trailer Axle Appl. for 16-1/2" Brakes	1-268
Meritor Clearance Sensing ASA - Transit Applications	1-269
Meritor Clearance Sensing ASA Hardware	1-276
Meritor Clearance Sensing ASA Service Bracket Kits	1-277
Safety Check Brake Gauges	1-284
Slack Adjusters - Automatic Crewson	1-281
Slack Adjusters - Automatic Haldex	1-261
Slack Adjusters - Automatic Meritor	1-258
Slack Adjusters - Manual	1-256

Section 1-4

Wedge Brake Kits - Bendix	1-288
Wedge Brake Kits - Meritor "Stopmaster"	1-297
Wedge Brake Lubricant	1-290
Wedge Brake Parts - Bendix	1-286
Wedge Brake Parts - Meritor "Stopmaster"	1-291

Exploded Views**Page**

Bendix 15" Brakes	1-1
Bendix 16-1/2" Brakes	1-2
Dexter 12-1/4" "S" Cam Air Brake	1-3
Dexter Trailer Axle With 12-1/4" Brakes	1-4
Dexter Trailer Axle With 16-1/2" Brakes	1-5
Eaton 15" Standard & "ES" "Extended Service" Brakes (Single Web)	1-6
Eaton 15" Standard & "ES" "Extended Service" Brakes (Double Web)	1-7
Eaton 15" "Reduced Envelope" Brakes	1-8
Eaton 16-12" 541 Series Brakes	1-9
Eaton 16-2" "ES" "Extended Service" Brakes	1-10
Eaton 16-2" "ES" "Extended Service" Brakes (Severe Service)	1-11
Eaton 16-2" "ES II" "Extended Service" Brakes	1-12
Eaton 18" Self-Contained Tractor Brakes	1-13
Eaton (Shuler) "C" & "E" Series Trailer Axle with 12-1/4" Brakes (SA Series)	1-14
Eaton (Shuler) "C", "E" & "J" Series Trailer Axle w/ 16-1/2" Brakes	1-16
Eaton (Shuler) 22R, 23R, 22L, 23L Series Trailer Axle with 16-1/2" Brakes	1-18
Eaton Top Spec "ES" Retrofit for Fruehauf 16-1/2" "XEM" Brakes	1-20
Eaton Top Spec "ES" Retrofit for Meritor 16-1/2" "Q" Brakes	1-20
Fruehauf "Pro-Par" Trailer Axle with 12-1/4" Brakes	1-21
Fruehauf "Pro-Par" Trailer Axle with 16-1/2" Brakes	1-23

INDEX

Foundation Air Brake Parts	Page
Hendrickson Intraax® Trailer Axle with 16-1/2" Brakes.....	1-25
Meritor Air Disc Brakes	1-27
Meritor Trailer Axles with 12-1/4" "Q" Brakes	1-28
Meritor "W" Series Cam Brakes with 14-1/2" x 4" & 6" Brakes.....	1-29
Meritor "W" Series Cam Brakes with 14-1/2" x 5" Brakes.....	1-30
Meritor "W" Series Cam Brakes with 14-1/2" x 8" & 10" Brakes - Type 1.....	1-31
Meritor "W" Series Cam Brakes with 14-1/2" x 10" Brakes - Type 2.....	1-32
Meritor "W" Series Cam Brakes with 14-1/2" x 10" Brakes - Type 3.....	1-33
Meritor "Q" Series 15" Cam Brakes for Steer Axles.....	1-34
Meritor Q Plus™ Series Cam Brakes with 15" Brakes for Steer Axles	1-35
Meritor Q Plus™ Series Cam Brakes for LX/MX 500 with Cast Spider.....	1-41
Meritor Q Plus™ Series Cam Brakes for LX/MX 500 with Stamped Spider.....	1-42
Meritor "T" Series 15" Cam Brakes.....	1-36
Meritor "T" Series 16-1/4" Cam Brakes	1-37
Meritor "Q" & "P" Series 16-1/2" Cam Brakes.....	1-38
Meritor Q Plus™ Series 16-1/2" Cam Brakes	1-39
Meritor "Q" & "P" Series 16-1/2" Cam Brakes for Mack Truck.....	1-40
Meritor "P" Series 18" Cast Cam Brakes	1-43
Meritor Early Model RL, RN & RQ Trailer Axles with 16-1/2" Brakes	1-44
Meritor Early Model TK, TKL Trailer Axles with 16-1/2" Brakes	1-45
Meritor TN, TP, TQ and TR Trailer Axles with 16-1/2" Brakes.....	1-46
Meritor Trailer Axles with 16-1/2" Brakes.....	1-47
Spicer (Dana) 12-1/4" "Fast Change II" Brakes (Before 11/1/96).....	1-49
Spicer (Dana) 12-1/4" "Fast Change II" Brakes (After 11/1/96).....	1-50
Spicer (Dana) D21 & 22 Axles with 16-1/2" Brakes.....	1-52
Standard Forge Axle with 12-1/4" Brakes	1-54
Standard Forge A-17, A-19 & A-22 Series Trailer Axle with 16-1/2" Brakes	1-56
Wagner 15" Brakes (Front Axle).....	1-58
Wagner 15" Brakes.....	1-59
Bendix 15" Wedge Brakes (Non-Servo)	1-60
Bendix 15" Wedge Brakes (Twin-Plex).....	1-61
Meritor "Stopmaster" 12-1/4" Wedge Brakes.....	1-62
Meritor "Stopmaster" 15" Wedge Brakes (Single Actuation)	1-63
Meritor "Stopmaster" 15" Wedge Brakes (Dual Actuation).....	1-64
Meritor "Stopmaster" 15" RSA Wedge Brakes (Dual Anchor Pin).....	1-65
Meritor "Stopmaster" 15" Wedge Brakes (Tractor)	1-66
Meritor "Stopmaster" 15" Wedge Brakes (Trailer)	1-67

BENDIX "BRAZILIAN" 15" DIAMETER BRAKES

STEER AXLE BRAKE

Part	Page
E-7230	1-159
E-7231	1-85
E-7232	1-85
E-7235	1-219

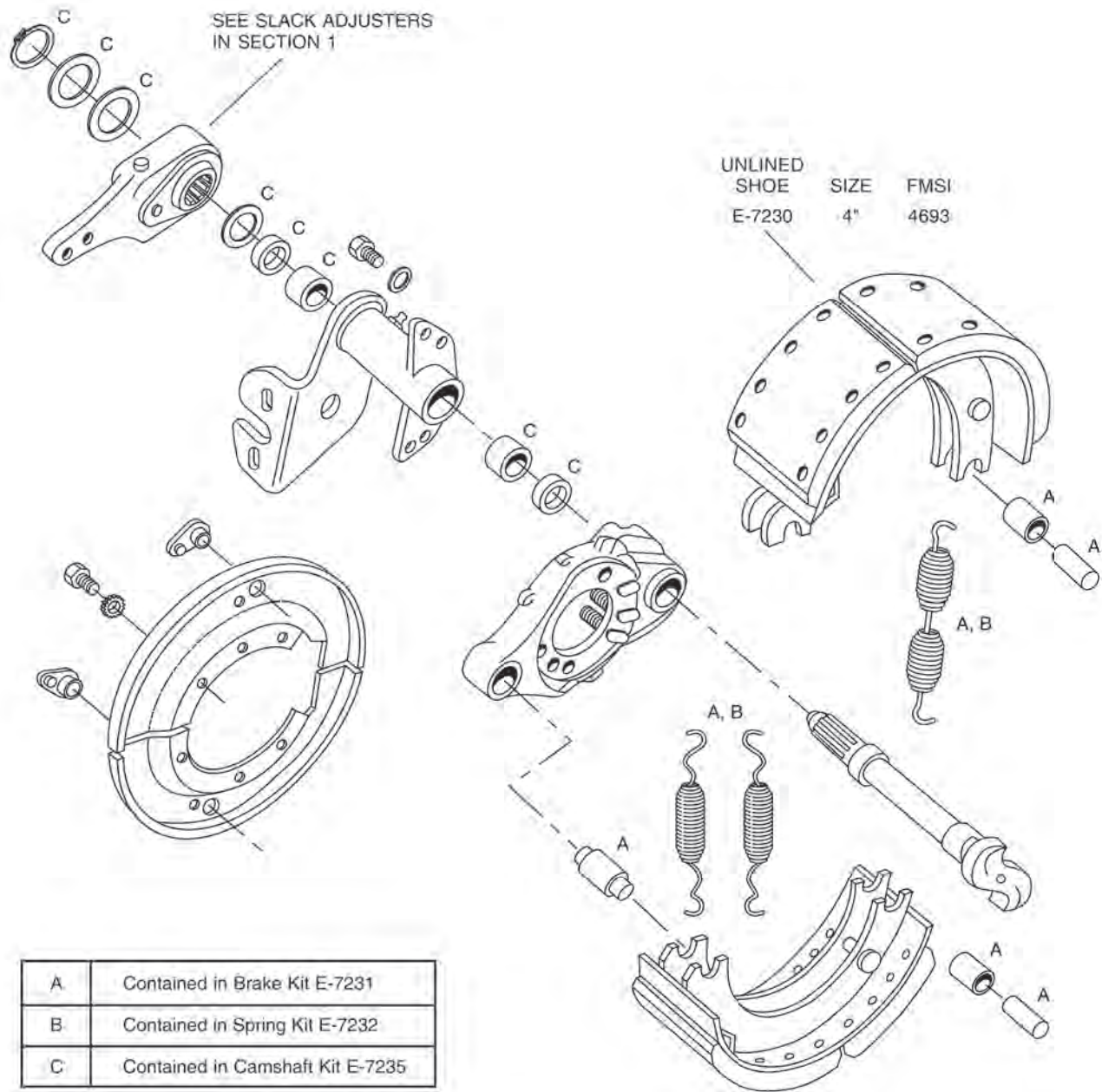

- Bendix 15" Steer Axle is the only dual web, single replaceable anchor pin design built prior to '95.
- Most common application is found on 1989-1991 Ford Bus & Cargo.

BENDIX "BRAZILIAN" 16 1/2" DIAMETER BRAKES

TRUCK AND TRACTOR BRAKE

PartPage

E-7236 1-159

E-7237 1-87

E-7238 1-87

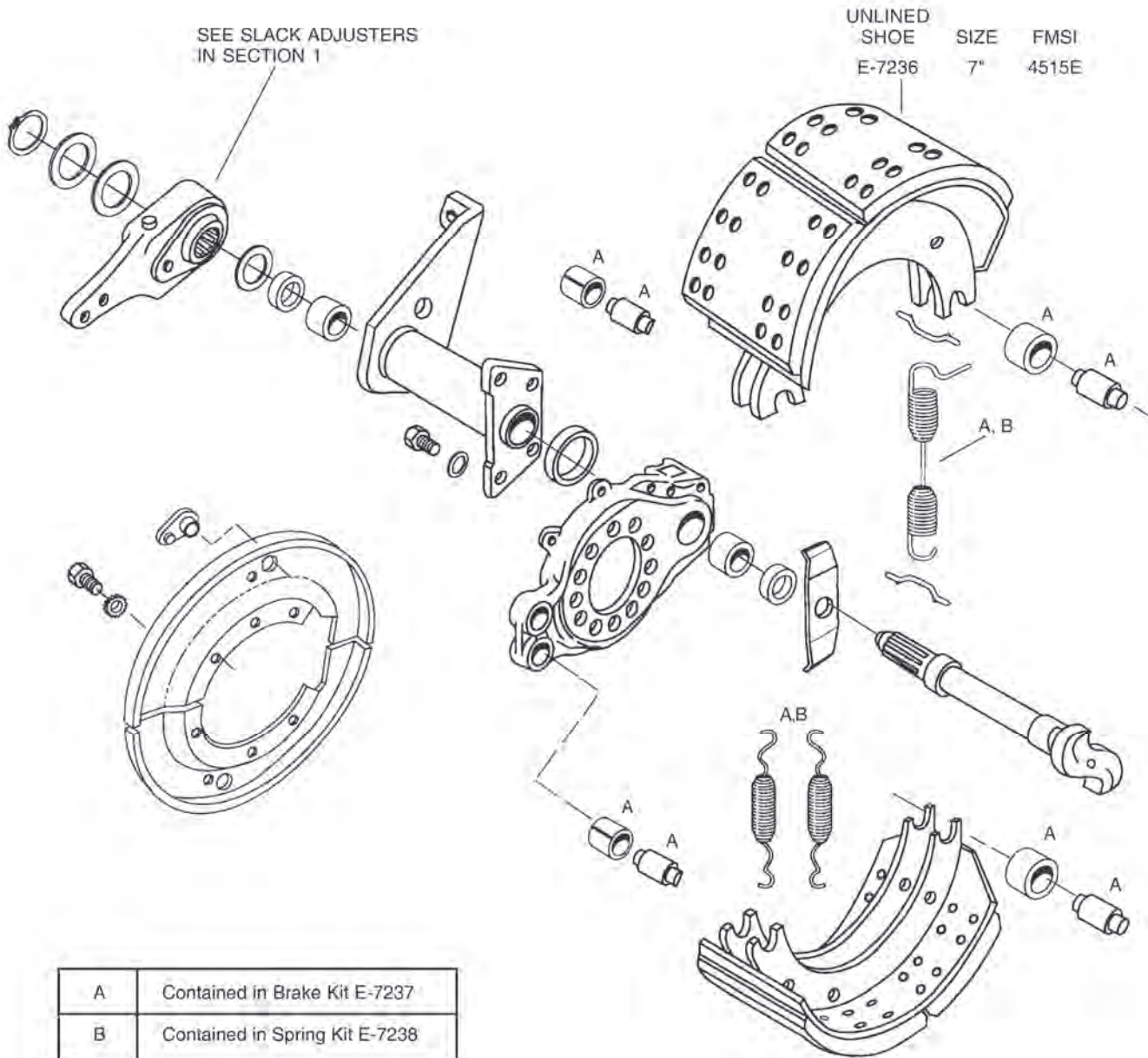

- Bendix 16 1/2" shoe is unique to this application. Never interchange with other shoe manufacturers.

DEXTER 12 1/4" "S" CAM AIR BRAKE

"PQ" STYLE BRAKE (After 5/96)

Part	Page
E-526	1-262
E-527	1-130
E-580	1-256
E-747	1-151
E-759	1-244
E-807	1-244
E-1416A	1-251
E-1893	1-139
E-2102	1-245
E-2103	1-235
E-2395	1-119
E-2396	1-122
E-2398	1-142
E-2404	1-259
E-2409	1-256
E-2469	1-211
E-2766S	1-123
E-2767	1-150
E-10875	1-74
E-10876	1-156
E-10877	1-156
E-10878	1-156

UNLINED SHOE	SIZE	FMSI
E-10876	4"	4700
E-10877	5"	4661C
E-10878	7 1/2"	4591

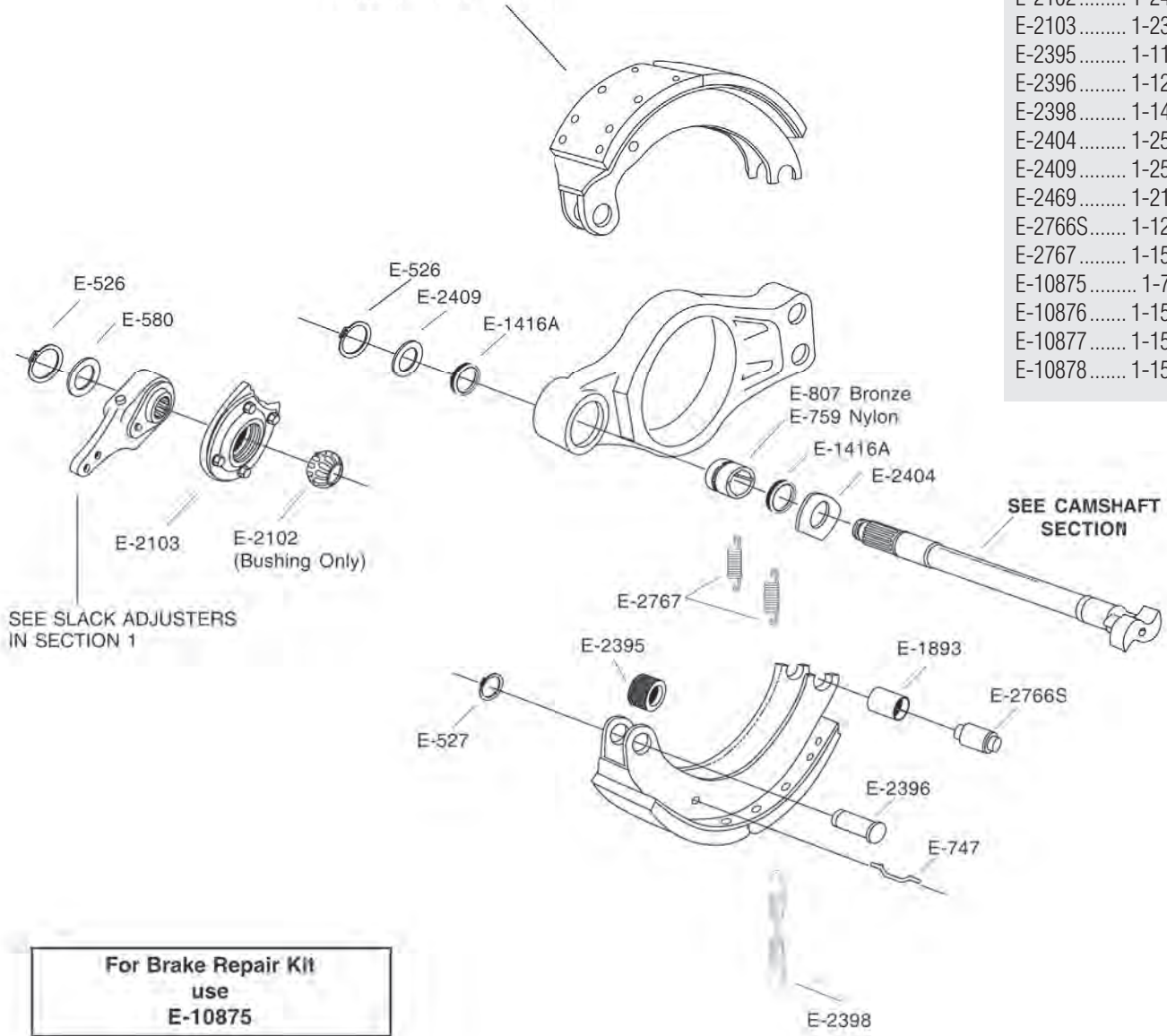

For Brake Repair Kit
use
E-10875

For Camshaft Repair Kit
use
E-2469

DEXTER TRAILER AXLE WITH 12 1/4" DIAMETER BRAKES

CAMSHAFT, BUSHINGS AND BRACKET PARTS

Part Page

E-526 1-262
 E-580 1-256
 E-759 1-244
 E-807 1-244
 E-1416A 1-251
 E-2102 1-245
 E-2103 1-235
 E-2404 1-259
 E-2409 1-256
 E-2469 1-211

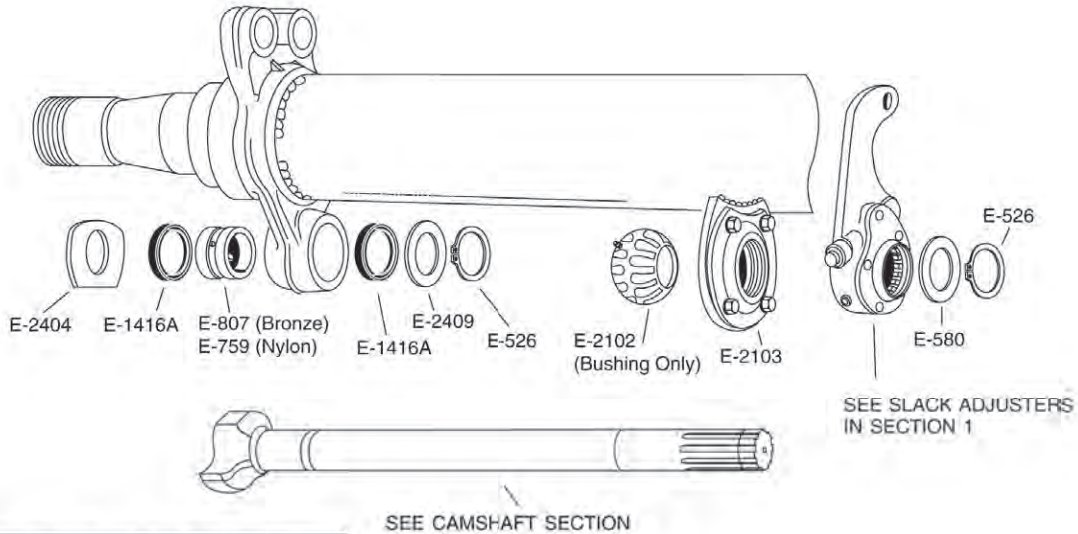

**For Camshaft Repair Kit
 use
 E-2469**

BRAKE SHOES AND HARDWARE Before 4/93

Part Page

E-527 1-130
 E-757 1-141
 E-2389 1-139
 E-2390 1-125
 E-2391 1-137
 E-2392 1-130
 E-2395 1-119
 E-2396 1-122
 E-2398 1-142
 E-2399 1-151
 E-2402HD 1-78
 E-3231 1-119
 E-9025 1-156
 E-9026 1-156

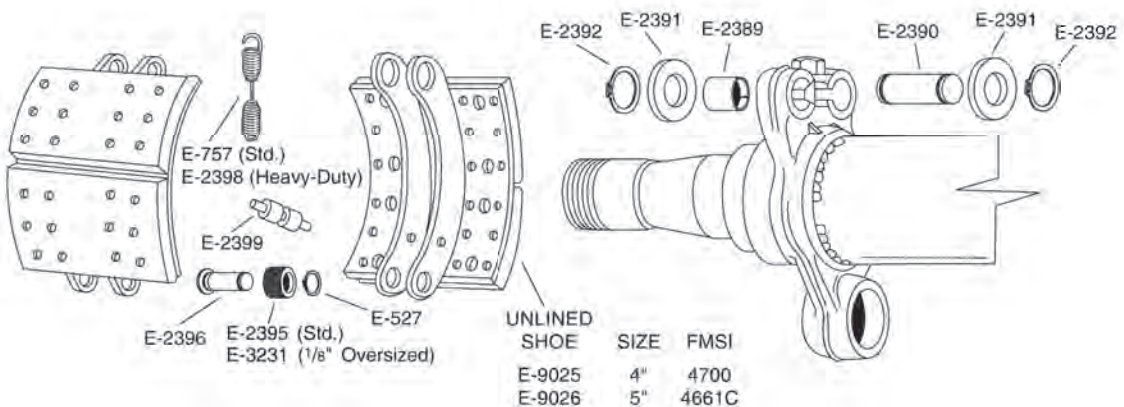

- Not interchangeable with other 12 1/4" Designs. Euclid recommends against replacing with "Q" Style shoes.

**For Brake Repair Kit
 use
 E-2402HD**

DEXTER TRAILER AXLE WITH 16 1/2" DIAMETER BRAKES

CAMSHAFT, BUSHINGS AND BRACKET PARTS

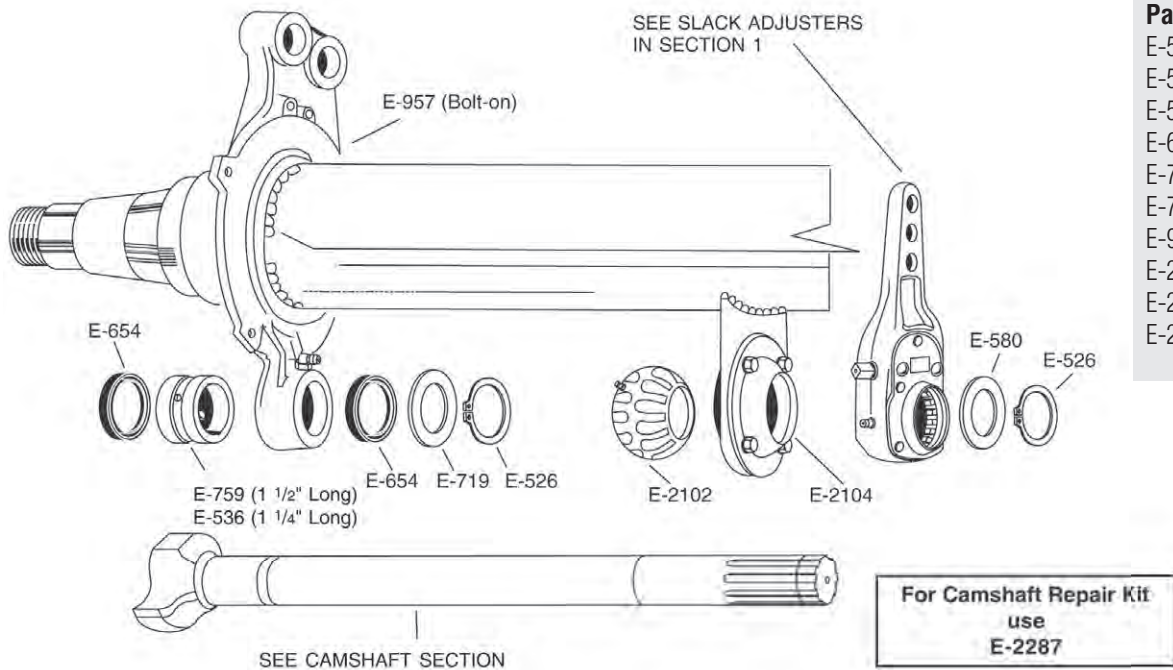

Part	Page
E-526	1-262
E-536	1-243
E-580	1-256
E-654	1-252
E-719	1-257
E-759	1-244
E-957	1-163
E-2102	1-245
E-2104	1-235
E-2287	1-225

BRAKE SHOES AND HARDWARE

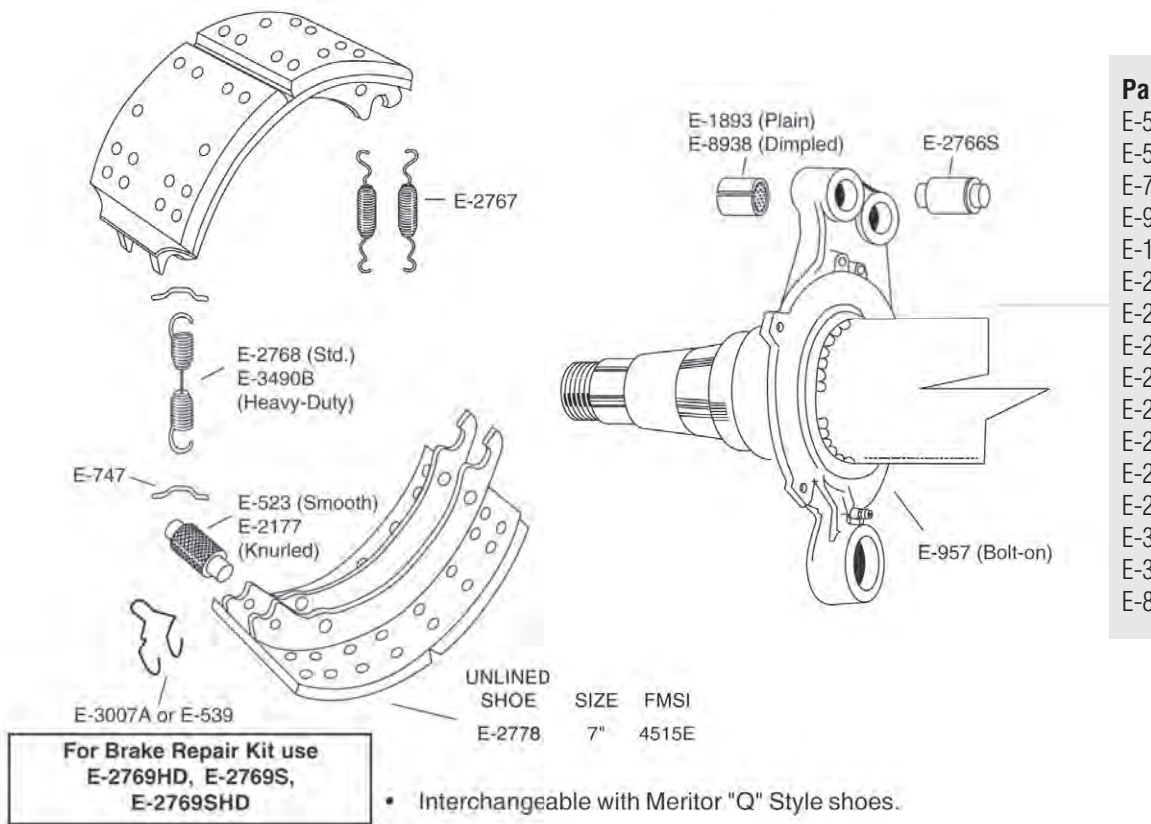

Part	Page
E-523	1-117
E-539	1-134
E-747	1-151
E-957	1-163
E-1893	1-139
E-2177	1-116
E-2766S	1-123
E-2767	1-150
E-2768	1-141
E-2769HD	1-101
E-2769S	1-102
E-2769SHD	1-103
E-2778	1-162
E-3007A	1-133
E-3490B	1-146
E-8938	1-139

EATON 15" DIAMETER STANDARD & "ES" EXTENDED SERVICE BRAKES

STEER AXLE BRAKE SINGLE WEB

PartPage

E-3234	1-260
E-3421A	1-118
E-4078	1-135
E-5122	1-149
E-5123	1-142
E-5124	1-134
E-5125	1-134
E-5126	1-158
E-5127	1-241
E-5128	1-250
E-5137	1-255
E-5138	1-255
E-5139	1-81
E-5140	1-218
E-9027	1-158

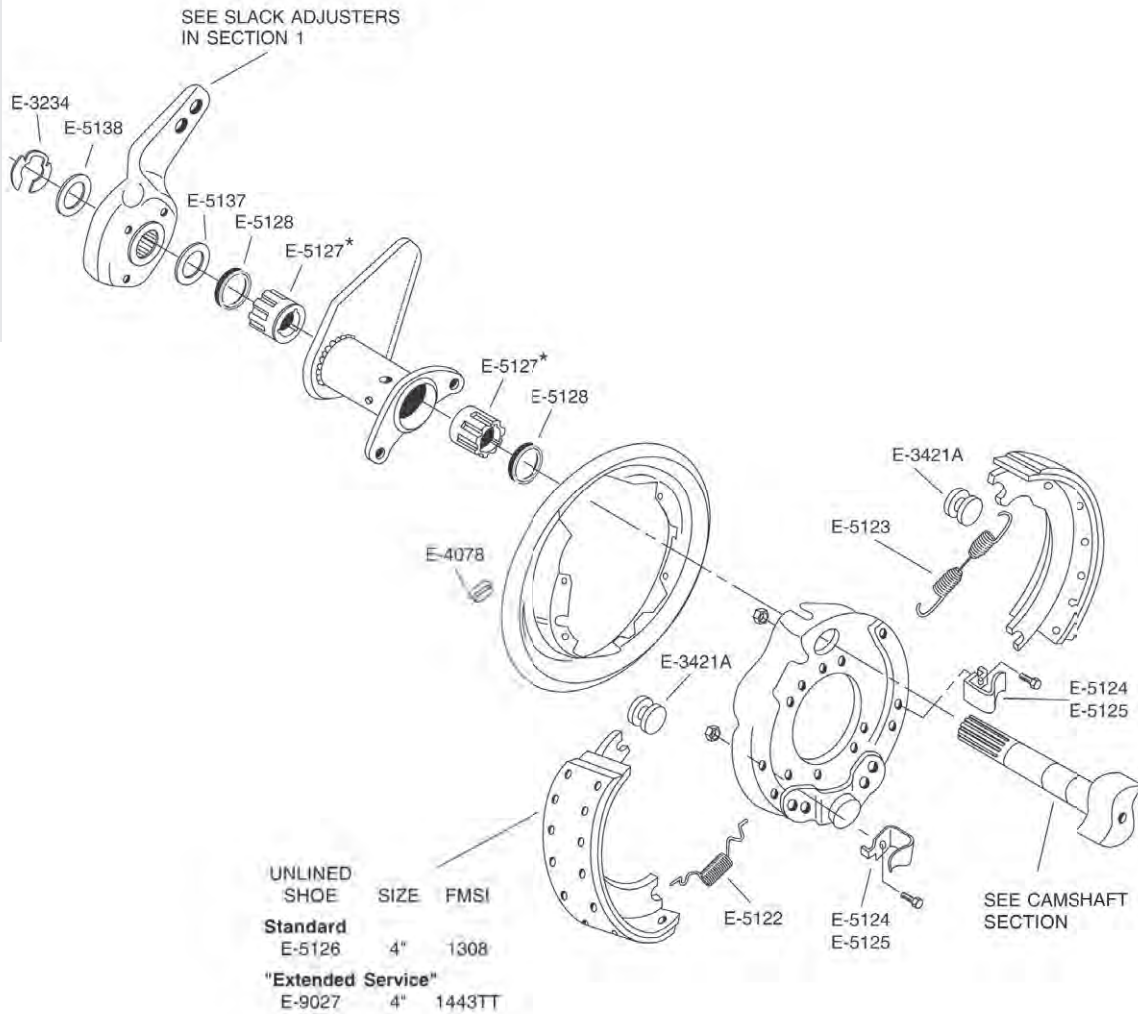

* Bushing, E-5127, is inverted in camshaft tube, see illustration above.

**For Brake Repair Kit
use
E-5139**

**For Camshaft Repair Kit
use
E-5140**

STEER AXLE BRAKE DOUBLE WEB

Part	Page
E-536	1-243
E-580	1-256
E-1416A	1-251
E-1781	1-254
E-1782	1-254
E-2125	1-215
E-3234	1-260
E-5477	1-116
E-5478	1-134
E-5482	1-258
E-10198	1-150
E-11980	1-143
E-11981	1-80
E-11982	1-159

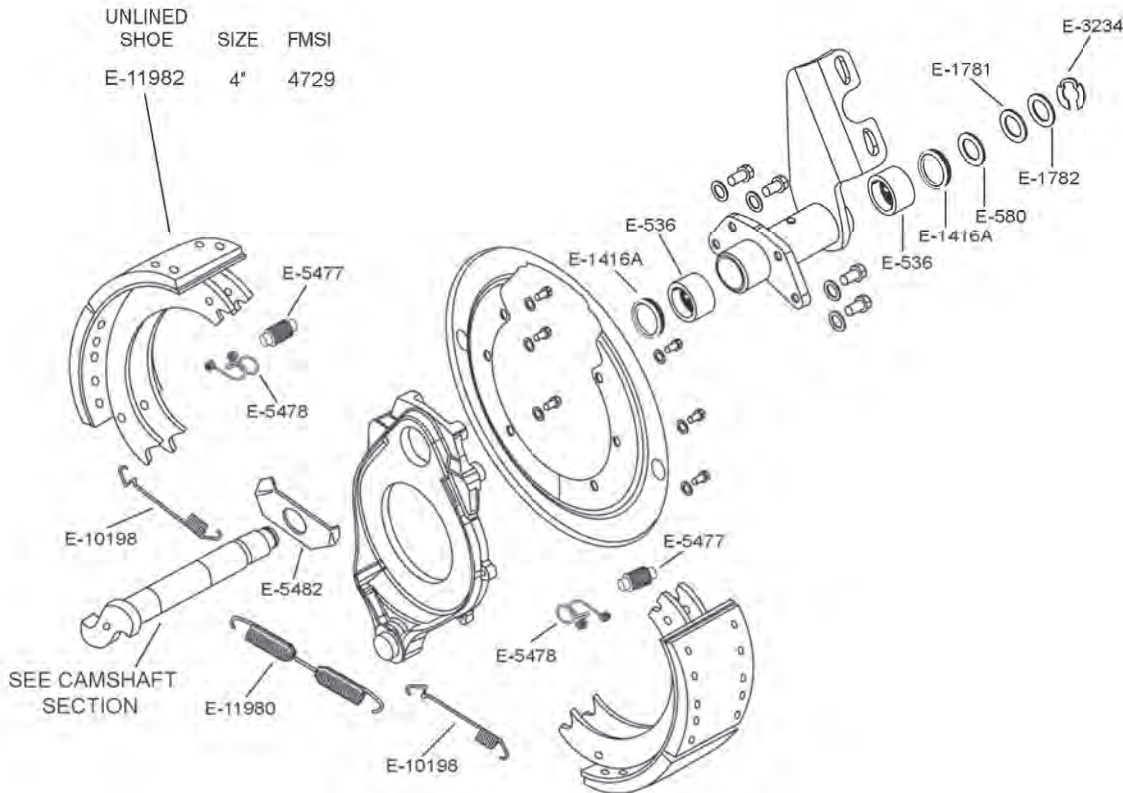

**For Brake Repair Kit
use
E-11981**

**For Camshaft Repair Kit
use
E-2125**

EATON 15" DIAMETER "REDUCED ENVELOPE" BRAKES

TRUCK AND TRACTOR BRAKE

PartPage

E-536	1-243
E-580	1-256
E-1416	1-250
E-1781	1-254
E-1782	1-254
E-2767	1-150
E-3234	1-260
E-5477	1-116
E-5478	1-134
E-5482	1-258
E-5501	1-215
E-9036	1-158
E-9037	1-142
E-9038	1-143
E-9039	1-86
E-9140	1-158
E-9141	1-86

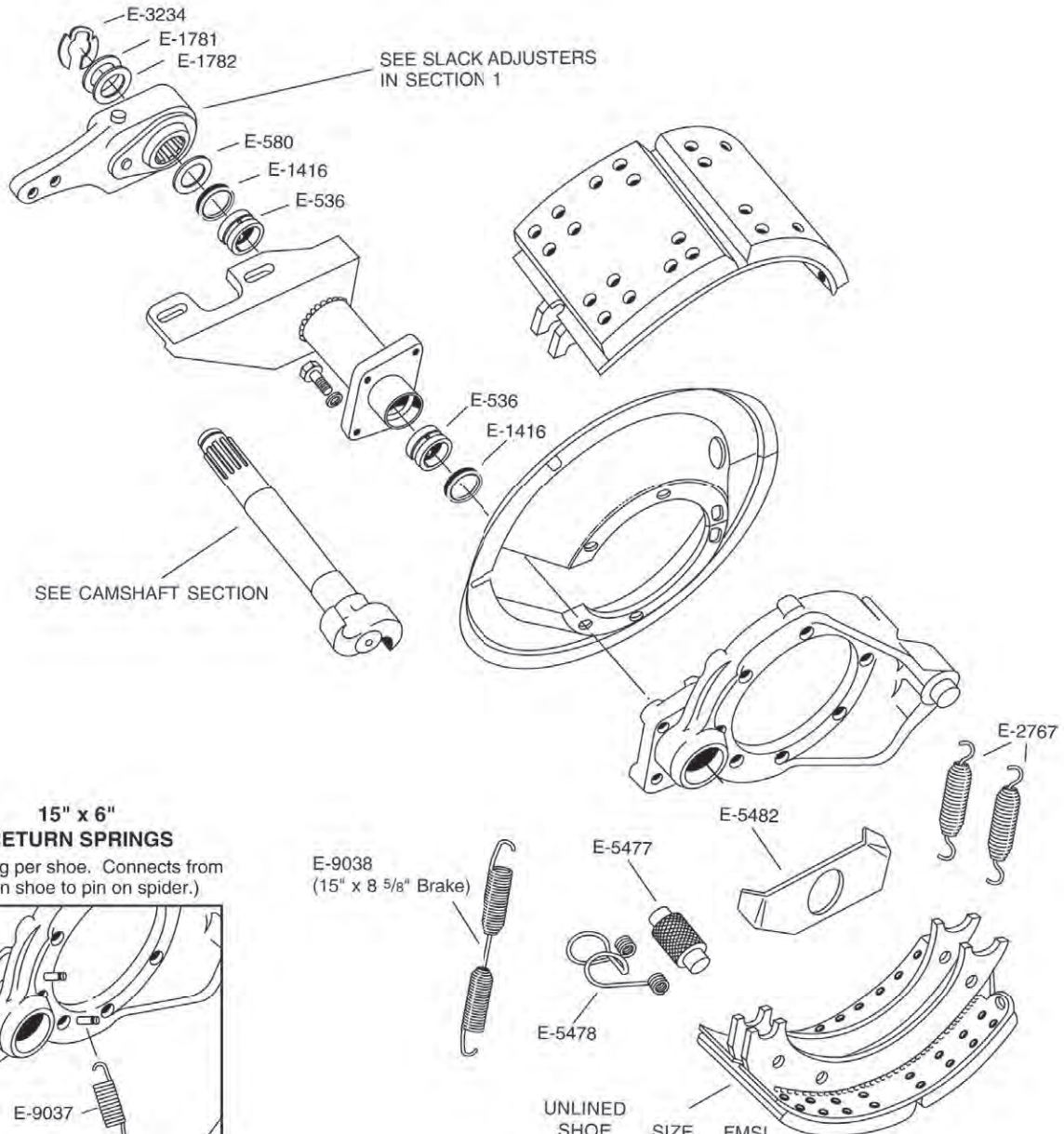

15" x 6" RETURN SPRINGS
 (1 spring per shoe. Connects from pin in shoe to pin on spider.)

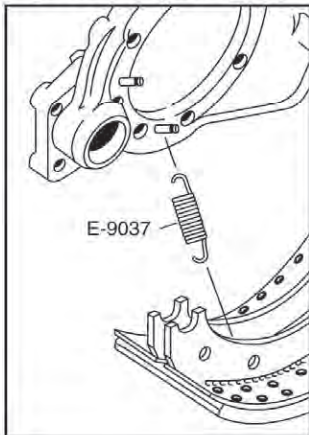

- Only dual web single non replaceable Anchor Pin design.

For Brake Repair Kit
 use E-9141 (6" Shoe)
 E-9039 (8 5/8" Shoe)

For Camshaft Repair Kit
 use E-5501

EATON 16 1/2" DIAMETER 541 SERIES BRAKES

TRUCK AND TRACTOR BRAKE WITH CAST SPIDER

SEE SLACK ADJUSTERS IN SECTION 1

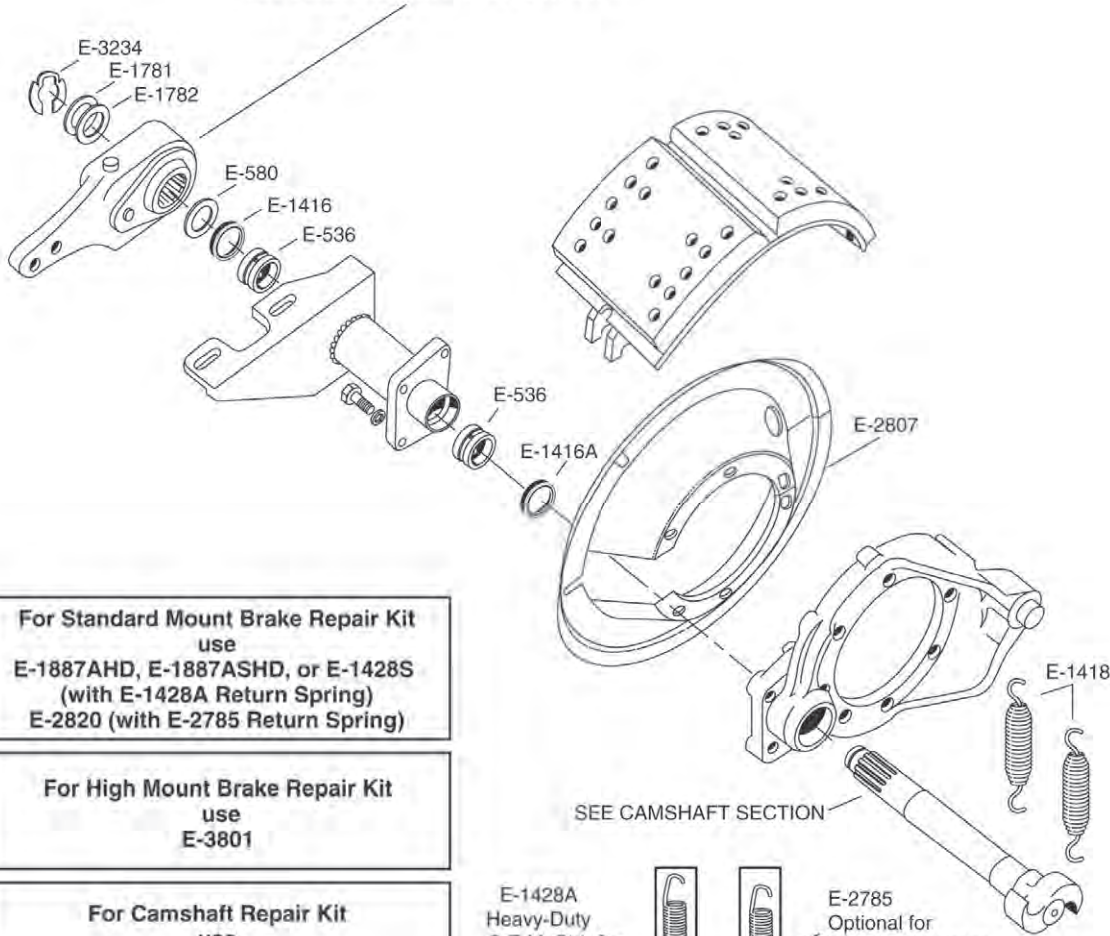

For Standard Mount Brake Repair Kit
use
E-1887AHD, E-1887ASHD, or E-1428S
(with E-1428A Return Spring)
E-2820 (with E-2785 Return Spring)

For High Mount Brake Repair Kit
use
E-3801

For Camshaft Repair Kit
use
E-2125

SEE CAMSHAFT SECTION

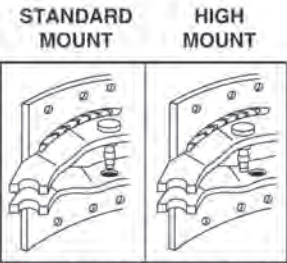
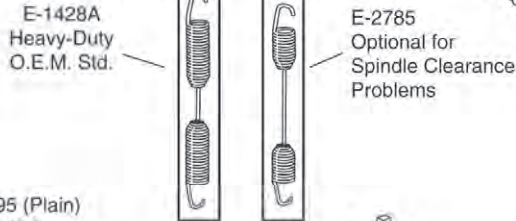

STANDARD MOUNT
Shoe E-1778
Use Spring E-1428A or E-2785

HIGH MOUNT
Shoe E-2819 & E-2474
Use Spring E-2475

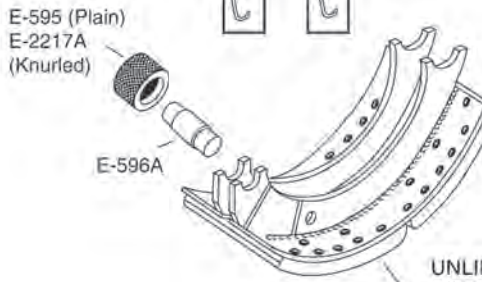

E-595 (Plain)
E-2217A (Knurled)

UNLINED SHOE	SIZE	FMSI
Standard Mount		
E-1777	6"	4317G
E-1778	7"	4311J
E-9054	8 5/8"	4674
High Mount		
E-2474	5"	4223A
E-9509	6"	4317
E-2819	7"	4311J

Part	Page
E-536	1-243
E-580	1-256
E-595	1-120
E-595A	1-122
E-1416	1-250
E-1418	1-149
E-1428A	1-147
E-1428S	1-147
E-1777	1-159
E-1778	1-159
E-1781	1-254
E-1782	1-254
E-1887AHD	1-90
E-1887ASHD	1-91
E-2125	1-215
E-2217A	1-119
E-2474	1-159
E-2475	1-147
E-2785	1-147
E-2807	1-166
E-2819	1-159
E-2820	1-91
E-3234	1-260
E-3801	1-92
E-9054	1-160
E-9509	1-159

- Upgrade to "ES II" with "ES II" Cam and "ES II" Kit.

EATON 16 1/2" DIAMETER "ES" EXTENDED SERVICE BRAKES

TRUCK AND TRACTOR BRAKE WITH FABRICATED SPIDER

Part	Page	Part	Page
E-536	1-243	E-5477	1-116
E-539	1-134	E-5478	1-134
E-580	1-256	E-5480	1-160
E-1416	1-250	E-5481A	1-88
E-1418	1-149	E-5482	1-258
E-1781	1-254	E-5501	1-215
E-1782	1-254	E-10197	1-147
E-3234	1-260		

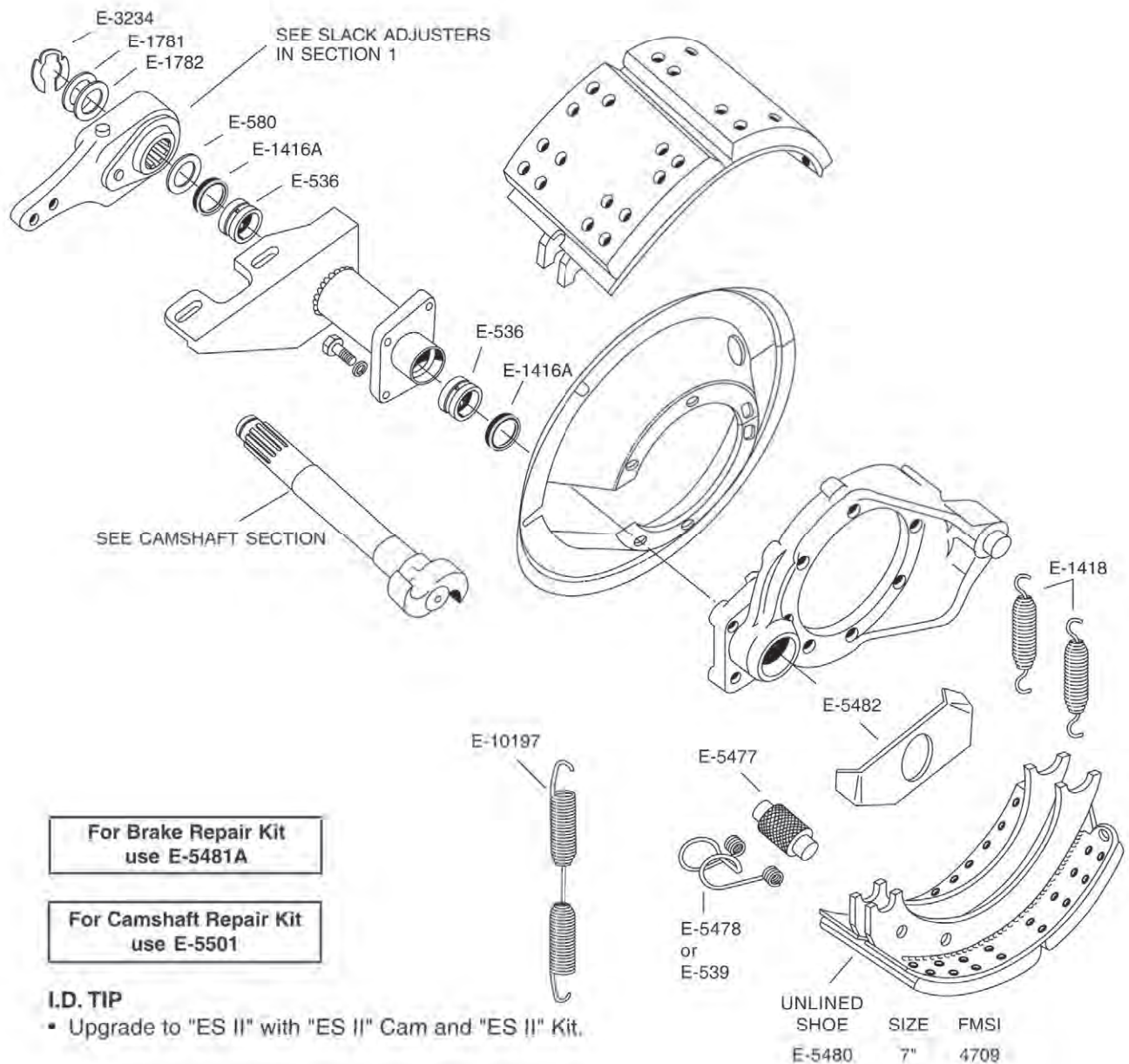

EATON 16 1/2" DIAMETER "ES" EXTENDED SERVICE BRAKES

SEVERE SERVICE CAST AND FABRICATED TRUCK AND TRACTOR BRAKE

Part	Page	Part	Page	Part	Page
E-536	1-243	E-1418	1-249	E-9041	1-126
E-539	1-134	E-1781	1-254	E-9042	1-135
E-580	1-256	E-1782	1-254	E-9043	1-121
E-667	1-243	E-2125	1-215	E-9044	1-121
E-747	1-151	E-2177	1-116	E-9045	1-134
E-801	1-131	E-3234	1-260	E-9046	1-144
E-919	1-140	E-5478	1-134	E-9047	1-138
E-1113	1-137	E-8907	1-146	E-9048	1-88
E-1416	1-250	E-9040	1-160	E-9052	1-88

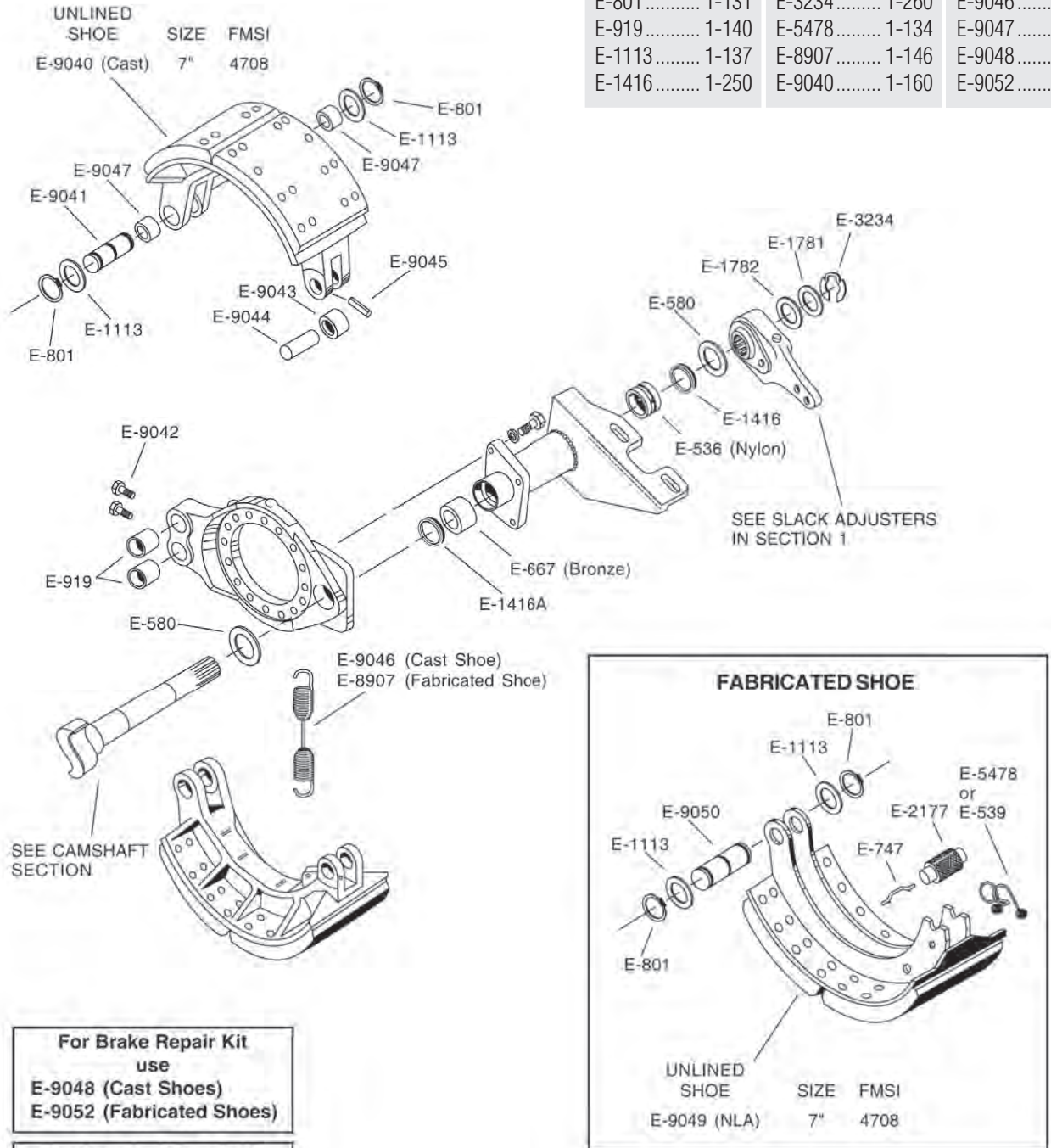

• Non Interchangeable with Meritor 16 1/2" design shoes.

EATON 16 1/2" DIAMETER "ES II" EXTENDED SERVICE BRAKES

TRUCK AND TRACTOR BRAKE

Part	Page	Part	Page
E-536	1-243	E-5482	1-258
E-580	1-256	E-9037	1-142
E-667	1-243	E-10197	1-147
E-801	1-131	E-10198	1-150
E-1416A	1-251	E-10244	1-89
E-1781	1-254	E-10270	1-160
E-1782	1-254	E-10271	1-160
E-3234	1-260	E-10273	1-160
E-5477	1-116	E-10760	1-90
E-5478	1-134	E-10897	1-214

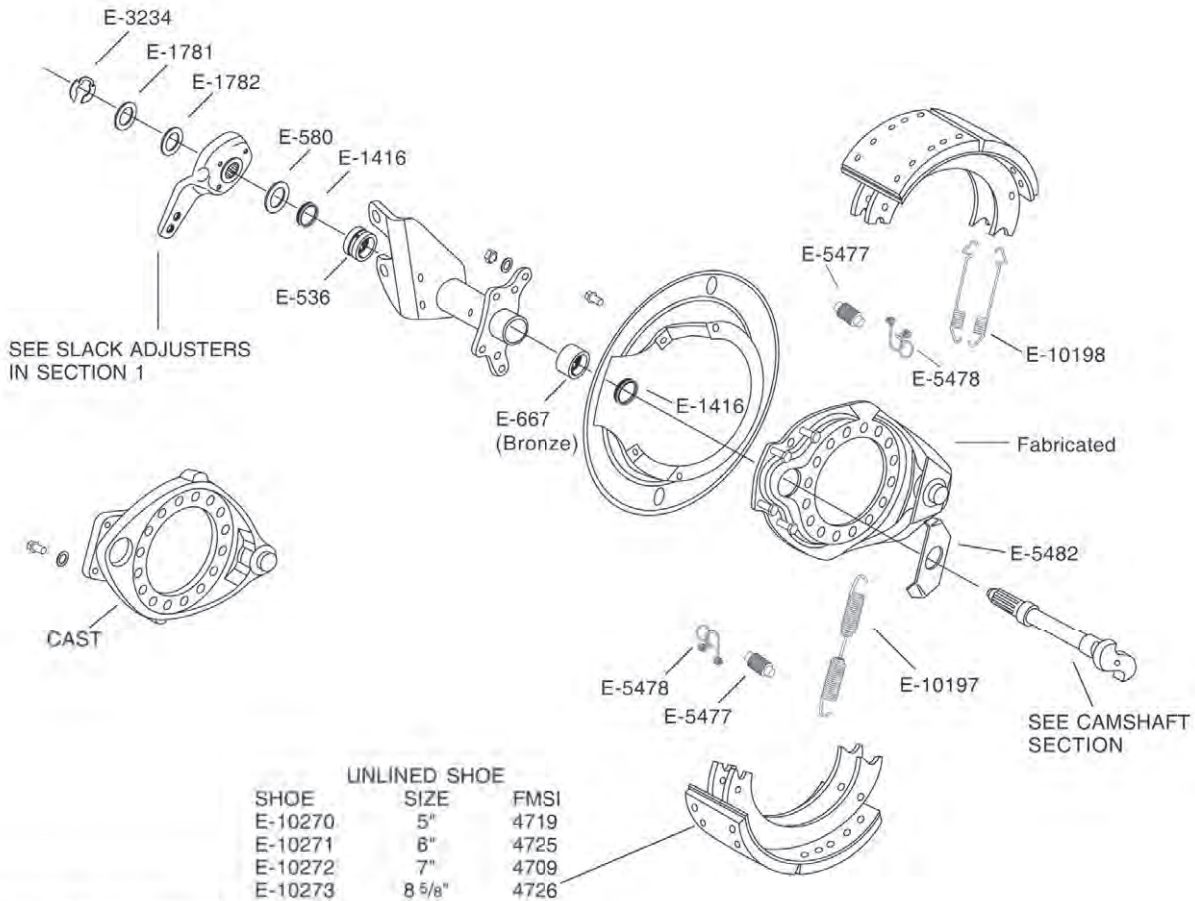

For Brake Repair Kit use
E-10244 (Drive Axle)
E-10760 (Steer Axle)

For Camshaft Repair Kit use E-10897

I.D. TIP

- E-10198 Retainer Springs are unique to the ES II design.
- E-10761 does not come with repair kit.

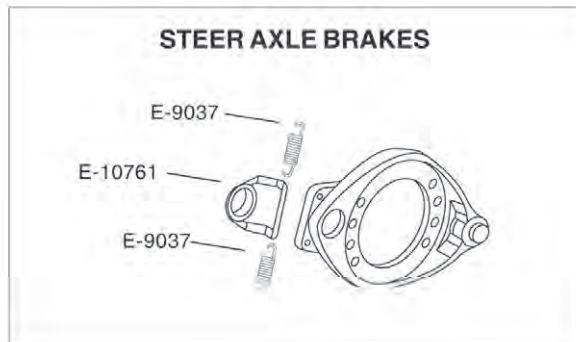

EATON 18" DIAMETER SELF-CONTAINED TRACTOR BRAKES

HEAVY-DUTY SERIES BRAKE WITH CAST BRAKE SHOES

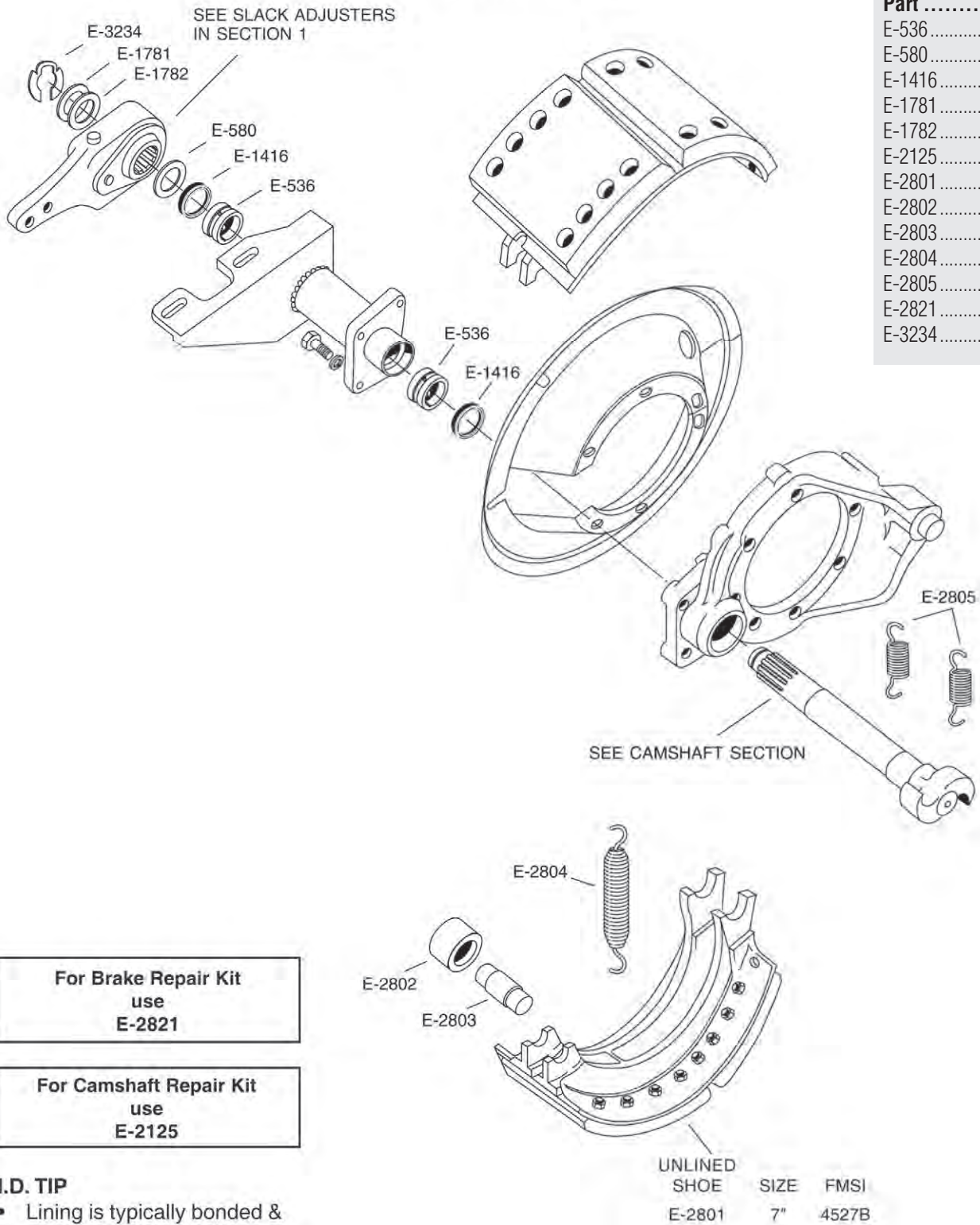

Part	Page
E-536	1-243
E-580	1-256
E-1416	1-250
E-1781	1-254
E-1782	1-254
E-2125	1-215
E-2801	1-162
E-2802	1-121
E-2803	1-123
E-2804	1-148
E-2805	1-150
E-2821	1-114
E-3234	1-177

**For Brake Repair Kit
use
E-2821**

**For Camshaft Repair Kit
use
E-2125**

I.D. TIP

- Lining is typically bonded & bolted to table.

PARTS FOR EATON (SHULER) "C" & "E"...

HUB CAPS, SPINDLE NUTS, SEALS & STUDS

Part

E-03009 See catalog
 E-04000 100WE for
 E-540 component
 E-572 details
 E-573
 E-975

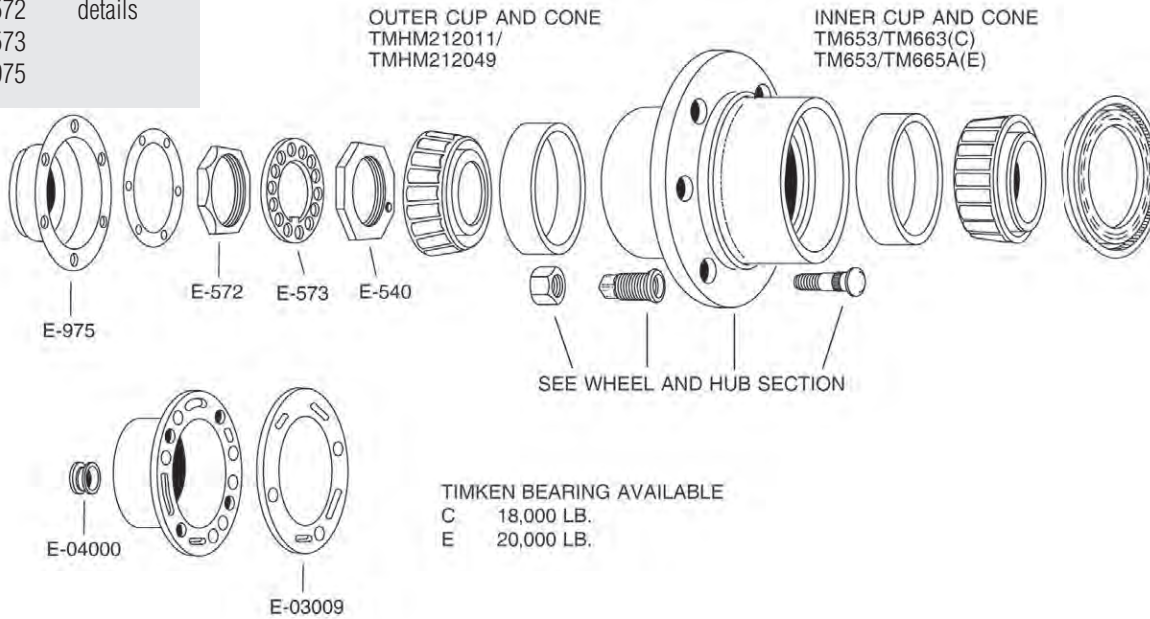

CAMSHAFT, BUSHINGS AND BRACKET PARTS

PartPage

E-526 1-262
 E-536 1-243
 E-580 1-256
 E-1385 1-245
 E-1416 1-250
 E-1569 1-262
 E-2091 1-265
 E-2494 1-212
 E-3473 1-258

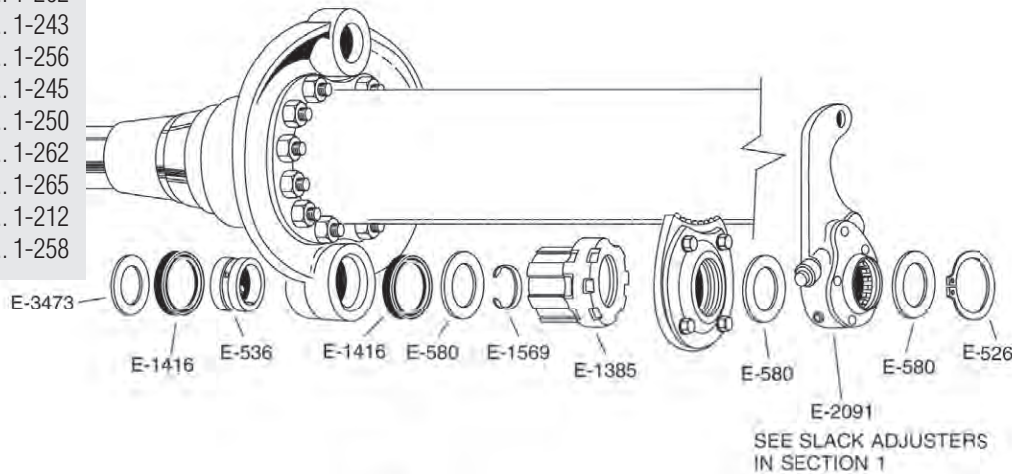

For Camshaft Repair Kit
 use
 E-2494

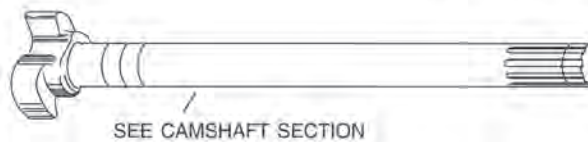

...SERIES TRAILER AXLE WITH 12 1/4" DIAMETER BRAKES

ANCHOR PIN VARIATIONS

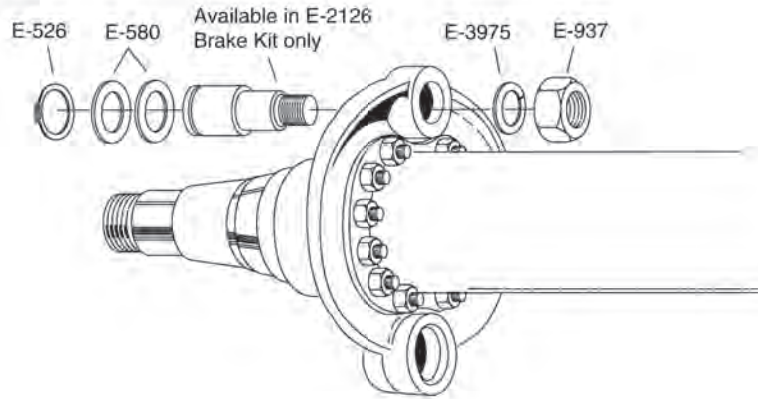

PartPage

E-526	1-262
E-580	1-256
E-937	1-133
E-2126	1-74
E-3975	1-136

**For Brake Repair Kit
use
E-2126**

SHOES, ROLLERS & SPRINGS

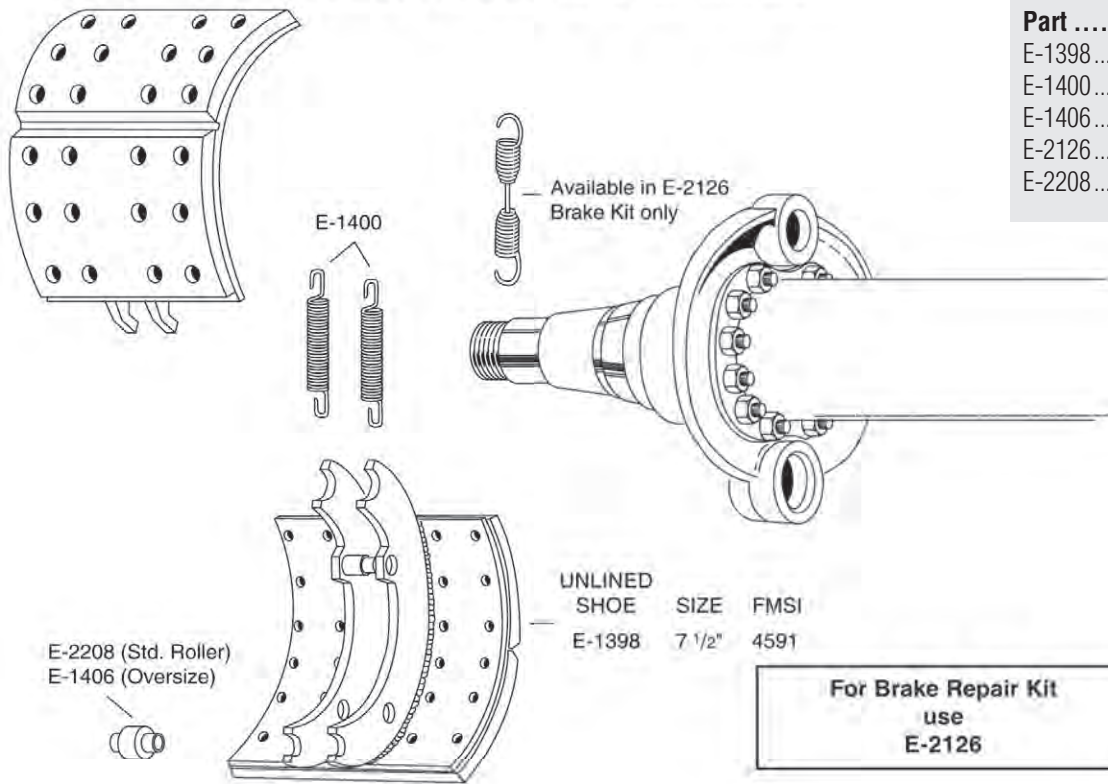

PartPage

E-1398	1-156
E-1400	1-141
E-1406	1-117
E-2126	1-74
E-2208	1-116

**For Brake Repair Kit
use
E-2126**

PARTS FOR EATON (SHULER) "C", "E" AND "J"...

HUB CAPS, SPINDLE NUTS, SEALS & STUDS

Part

E-03009 See catalog
 E-04000 100WE for
 E-540 component
 E-572 details
 E-573
 E-975

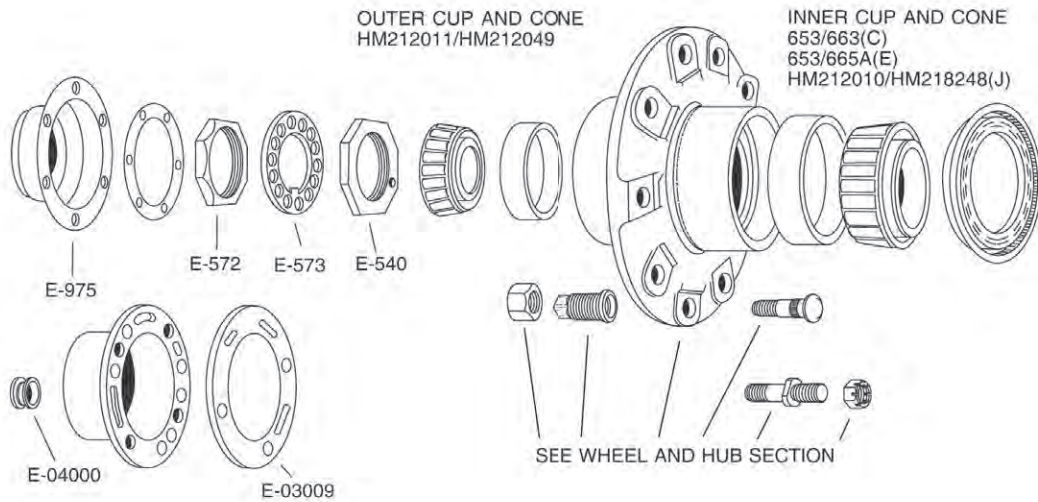

CAMSHAFT, BUSHINGS AND BRACKET PARTS

501 SERIES CAMSHAFT PARTS

PartPage

E-526 1-262
 E-536 1-243
 E-580 1-256
 E-1385 1-245
 E-1416 1-250
 E-1416A 1-251
 E-1565 1-257
 E-1569 1-262
 E-2089 1-224
 E-2123 1-225
 E-2405 1-253
 E-2690A 1-247
 E-2695 1-246
 E-2696A 1-227

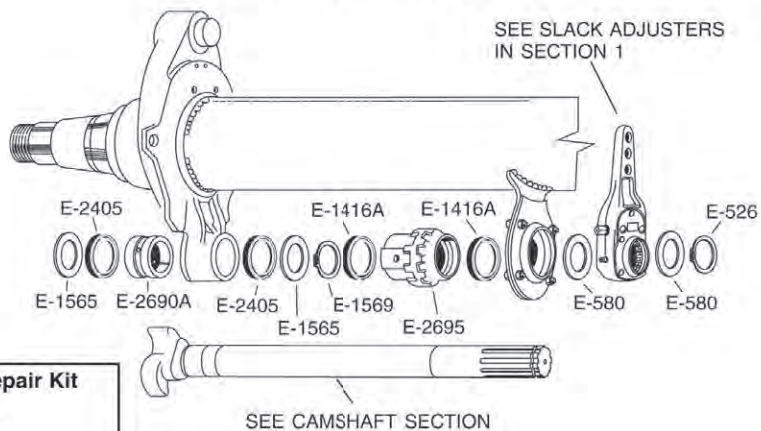

OLD STYLE FTL BRAKES

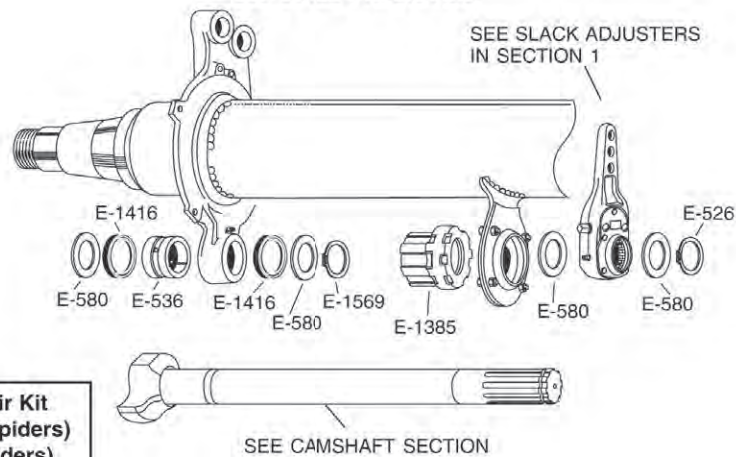

...SERIES TRAILER AXLE WITH 16 1/2" DIAMETER BRAKES

FTL SERIES DOUBLE ANCHOR PIN

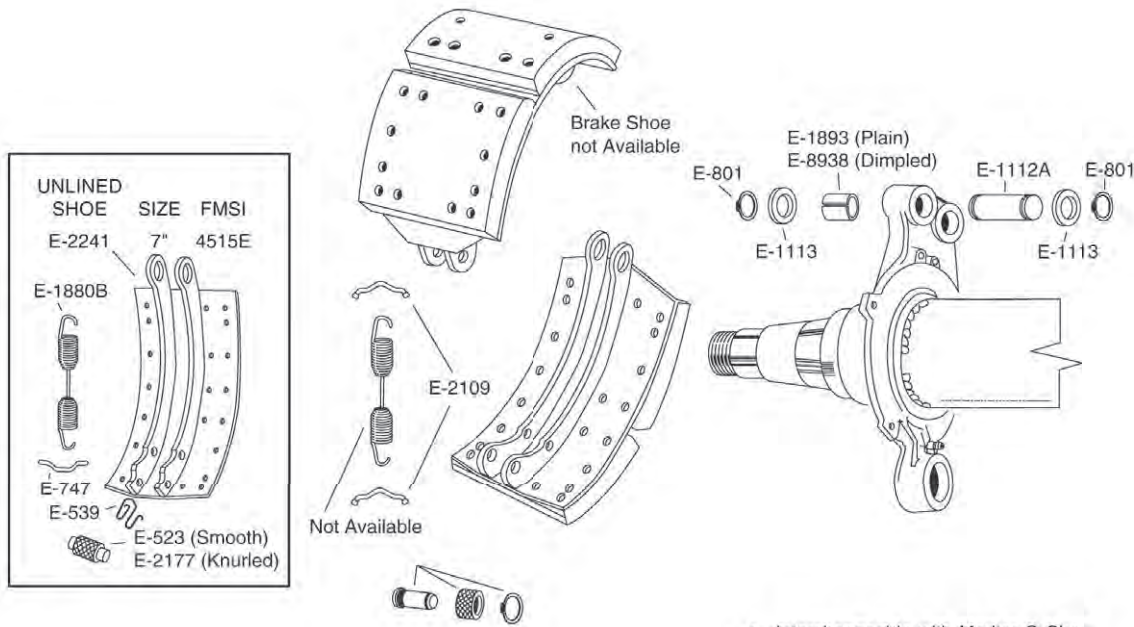

Part	Page
E-523	1-117
E-539	1-134
E-747	1-151
E-801	1-131
E-1112A	1-125
E-1113	1-137
E-1880B	1-145
E-1893	1-139
E-2109	1-151
E-2177	1-116
E-2241	1-161
E-8938	1-139

• Interchangeable with Meritor Q Shoe

501 SERIES SINGLE ANCHOR PIN

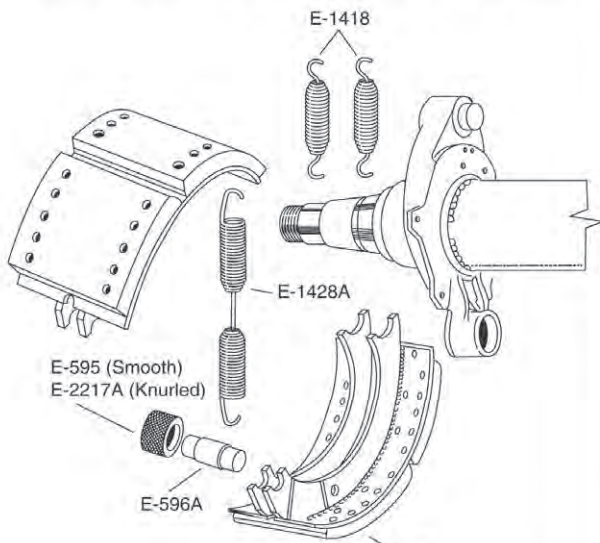

For Brake Repair Kit use E-1887AHD or E-1887ASHD

UNLINED SHOE	SIZE	FMSI
E-1777	6"	4317G
E-1778	7"	4311J
E-9054	8 5/8"	4674

"ES" "EXTENDED SERVICE"

For Brake Repair Kit use E-5481A

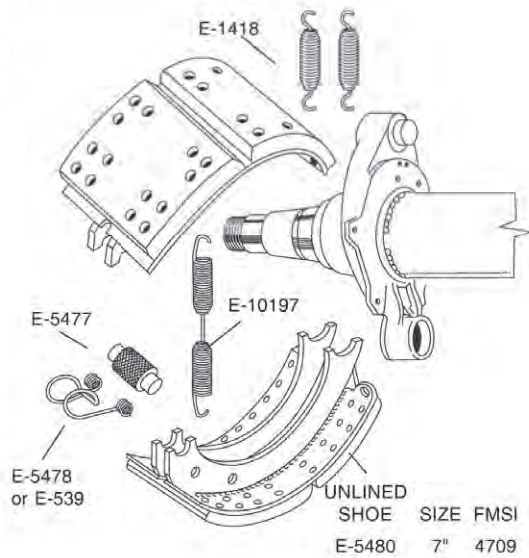

UNLINED SHOE	SIZE	FMSI
E-5480	7"	4709

Part	Page
E-539	1-134
E-595	1-120
E-596A	1-122
E-1418	1-249
E-1428A	1-147
E-1777	1-159
E-1778	1-159
E-1880B	1-145
E-1893	1-139
E-2109	1-151
E-2177	1-116
E-2241	1-161
E-8938	1-139
E-1887AHD	1-90
E-1887ASHD	1-91
E-2217A	1-119
E-5477	1-116
E-5478	1-134
E-5480	1-160
E-5481A	1-88
E-10197	1-147

PARTS FOR EATON (SHULER) 22R, 23R, 22L, 23L...

HUB CAPS, SPINDLE NUTS, SEALS & STUDS

Part

E-03009 See catalog
 E-04000 100WE for
 E-540 component
 E-572 details
 E-573
 E-975

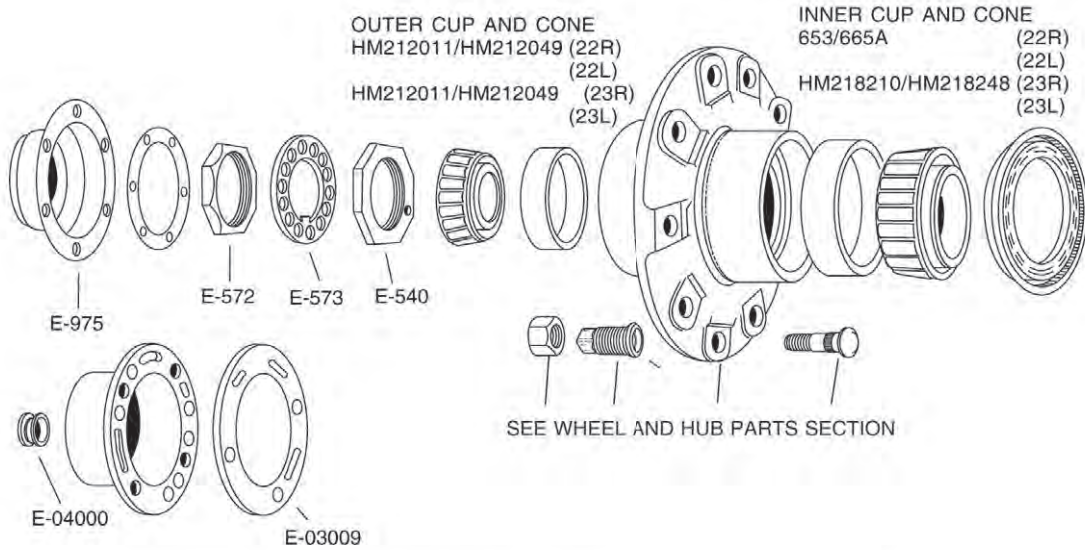

CAMSHAFT, BUSHINGS AND BRACKET PARTS

501 SERIES CAMSHAFT PARTS

PartPage

E-526 1-262
 E-536 1-243
 E-580 1-256
 E-1385 1-245
 E-1416 1-250
 E-1416A 1-251
 E-1565 1-257
 E-1569 1-262
 E-2123 1-225
 E-2405 1-253
 E-2690A 1-247
 E-2695 1-246
 E-2696A 1-227

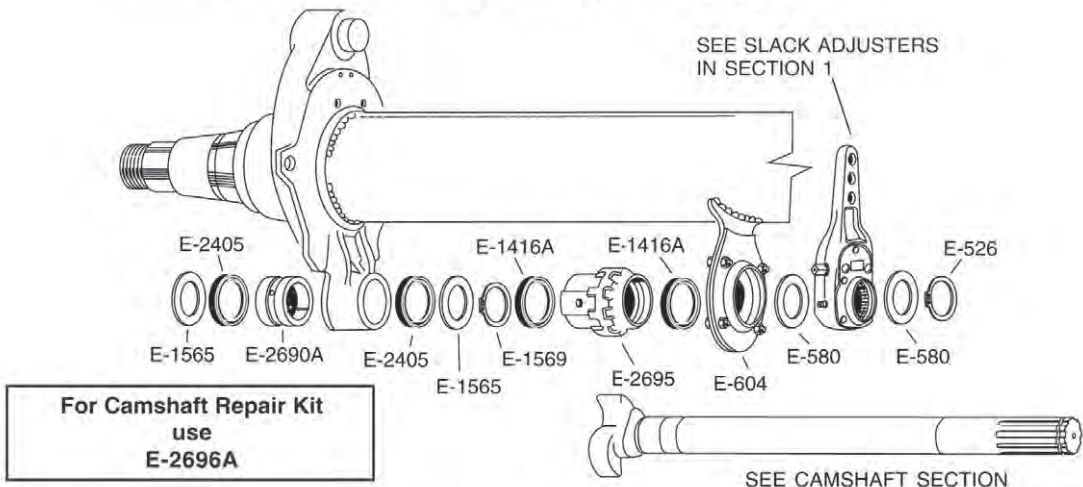

OLD STYLE FTL BRAKES

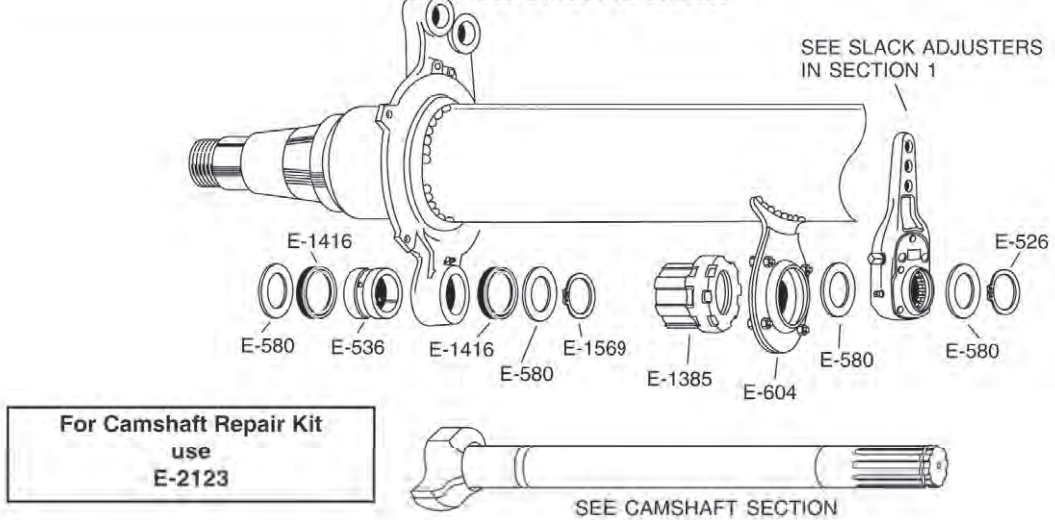

...SERIES TRAILER AXLE WITH 16 1/2" DIAMETER BRAKES

FTL SERIES DOUBLE ANCHOR PIN

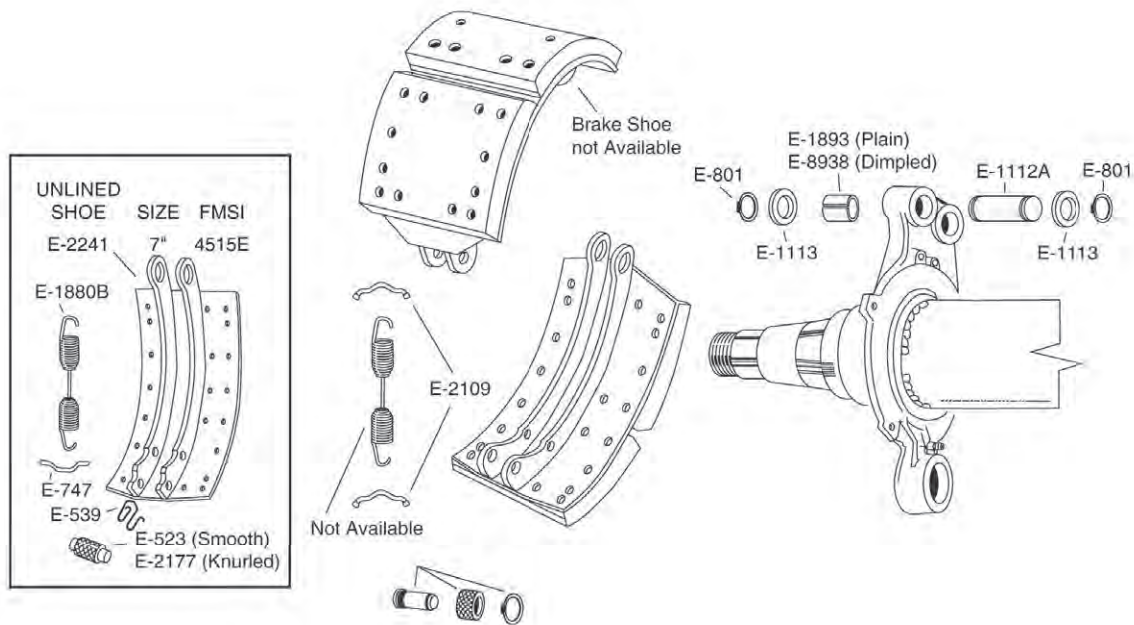

PartPage

E-523 1-117
 E-539 1-134
 E-747 1-151
 E-801 1-131
 E-1112A 1-125
 E-1113 1-137
 E-1880B 1-145
 E-1893 1-139
 E-2109 1-151
 E-2177 1-116
 E-2241 1-161
 E-8938 1-139

501 SERIES SINGLE ANCHOR PIN

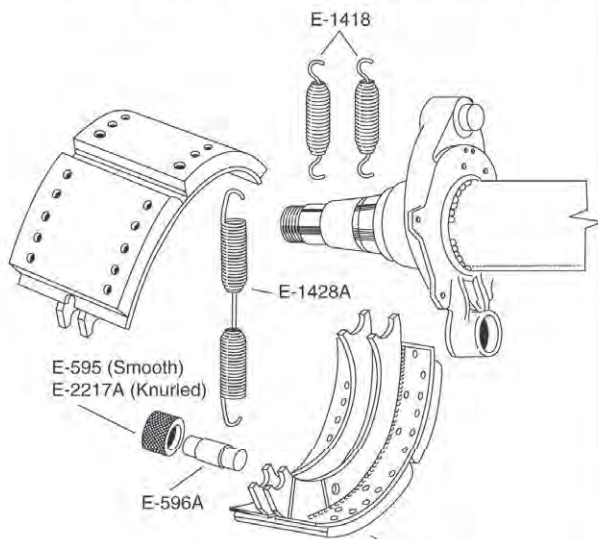

**For Brake Repair Kit use
 E-1887AHD or E-1887ASHD**

UNLINED SHOE	SIZE	FMSI
E-1777	6"	4317G
E-1778	7"	4311J
E-9054	8 5/8"	4674

"ES" "EXTENDED SERVICE"

**For Brake Repair Kit use
 E-5481A**

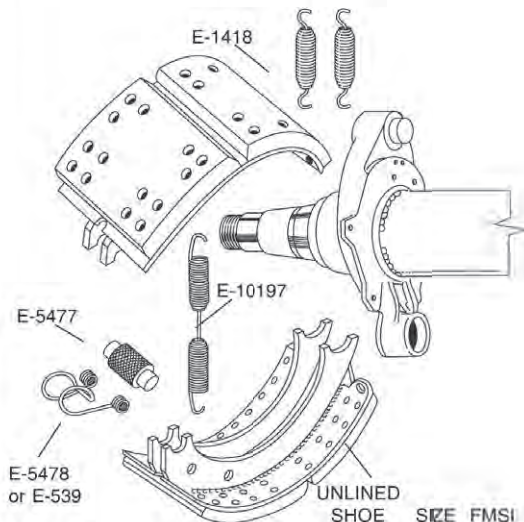

UNLINED SHOE	SIZE	FMSI
E-5480	7"	4709

PartPage

E-539 1-134
 E-595 1-120
 E-596A 1-122
 E-1418 1-249
 E-1428A 1-147
 E-1777 1-159
 E-1778 1-159
 E-1887AHD 1-90
 E-1887ASHD 1-91
 E-2217A 1-119
 E-5477 1-116
 E-5478 1-134
 E-5480 1-160
 E-5481A 1-88
 E-10197 1-147

EATON TOP SPEC "ES" RETROFIT FOR FRUEHAUF 16 1/2" DIAMETER "XEM" BRAKES

Part	Page
E-539	1-134
E-747	1-151
E-2177	1-116
E-2767	1-150
E-3711	1-124
E-8907	1-146
E-8922	1-160
E-8923	1-92
E-8938	1-139

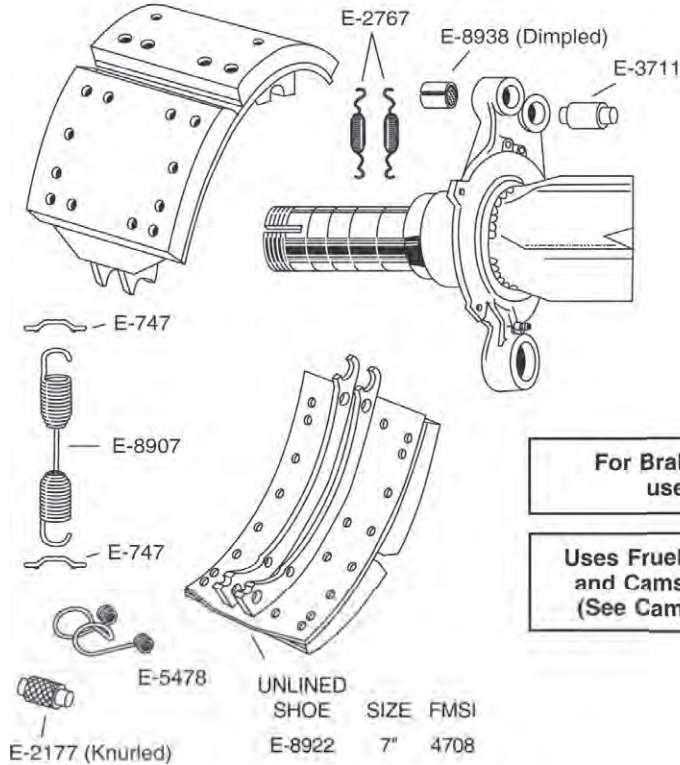

For Brake Repair Kit
use E-8923

Uses Fruehauf Camshafts
and Camshaft Hardware
(See Camshaft Section)

EATON TOP SPEC "ES" RETROFIT FOR MERITOR 16 1/2" DIAMETER "Q" BRAKES

Part	Page
E-539	1-134
E-747	1-151
E-886	1-165
E-2177	1-116
E-2766S	1-123
E-2767	1-150
E-3775	1-166
E-8907	1-146
E-8924	1-160
E-8925	1-93
E-8938	1-139

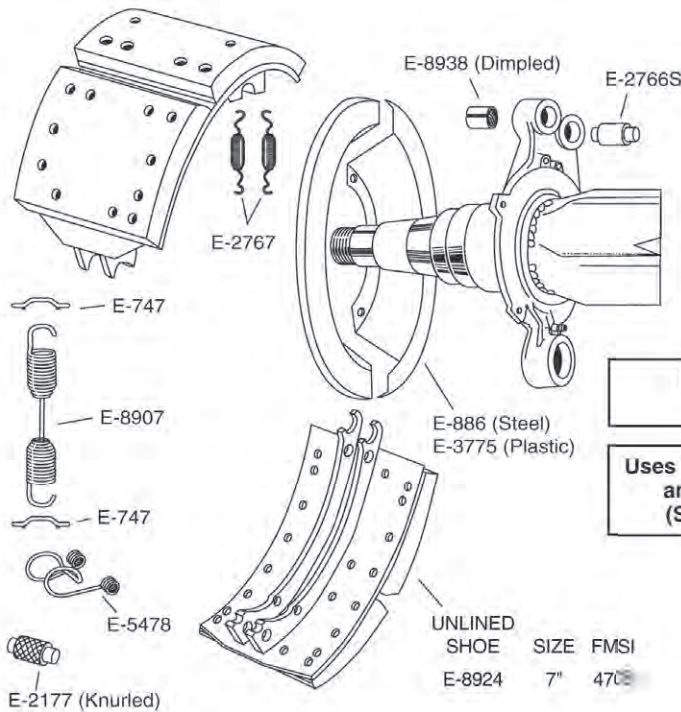

For Brake Repair Kit
use E-8925

Uses Meritor Q Plus Camshafts
and Camshaft Hardware
(See Camshaft Section)

PARTS FOR FRUEHAUF "PRO-PAR" TRAILER AXLE WITH 12 1/4" DIAMETER BRAKES HUB CAPS, SPINDLE NUTS, SEALS & STUDS

Part	
E-04000	
E-04075	See catalog
E-04075H	100WE for
E-05500	component
E-1559	details
E-1561	
E-2550	

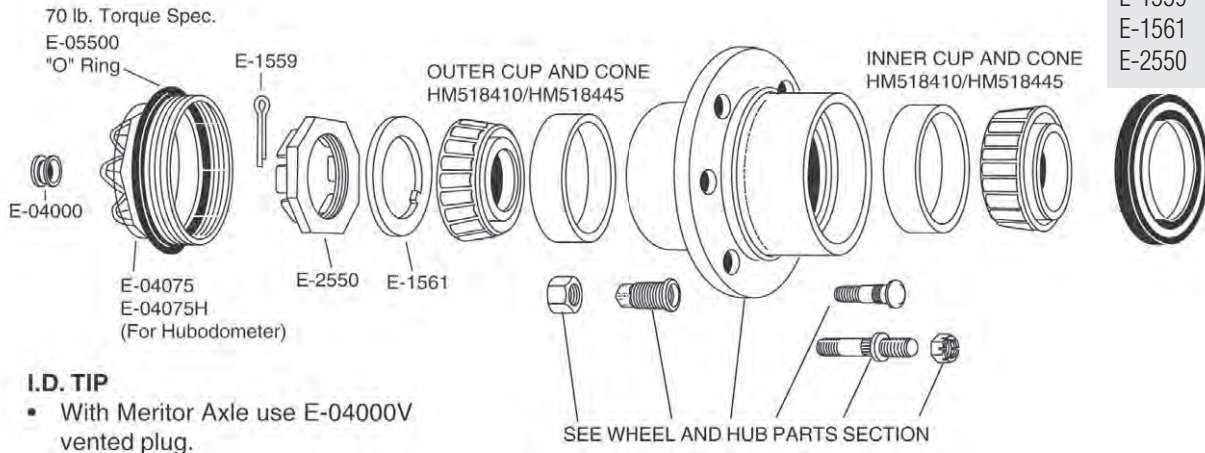

- I.D. TIP**
- With Meritor Axle use E-04000V vented plug.

CAMSHAFT, BUSHINGS AND BRACKET PARTS

- I.D. TIP**
- Fruehauf 3" Center-to-Center

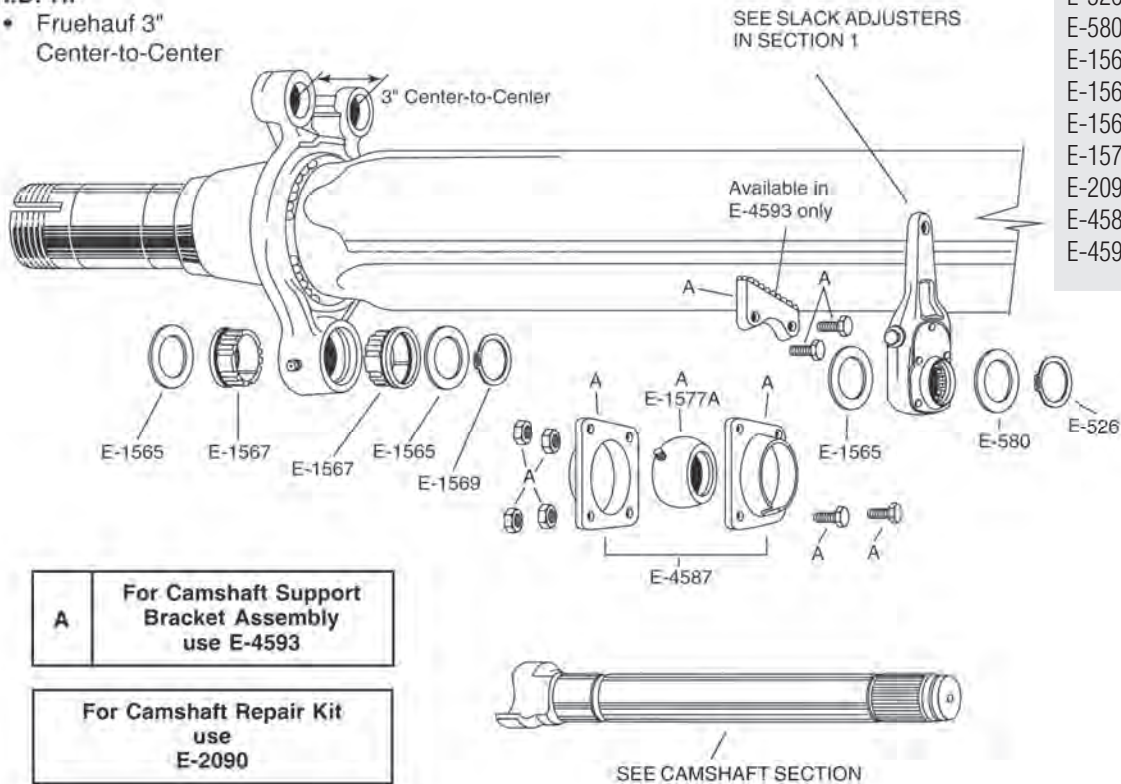

Part	Page
E-526	1-262
E-580	1-256
E-1565	1-257
E-1567	1-247
E-1569	1-262
E-1577A	1-246
E-2090	1-224
E-4587	1-238
E-4593	1-238

A	For Camshaft Support Bracket Assembly use E-4593
For Camshaft Repair Kit use E-2090	

PARTS FOR FRUEHAUF "PRO-PAR" TRAILER AXLE WITH 12 1/4" DIAMETER BRAKES

PartPage

E-801 1-131
 E-920 1-140
 E-1112A 1-125
 E-1113 1-137
 E-1893 1-139
 E-2286 1-74
 E-8938 1-139

ANCHOR PIN HARDWARE

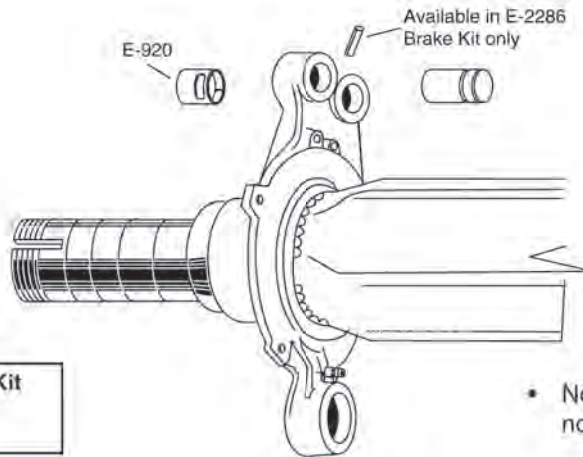

For Brake Repair Kit use
E-2286

• Not interchangeable with non Fruehauf Shoes

ALTERNATE ANCHOR PIN HARDWARE

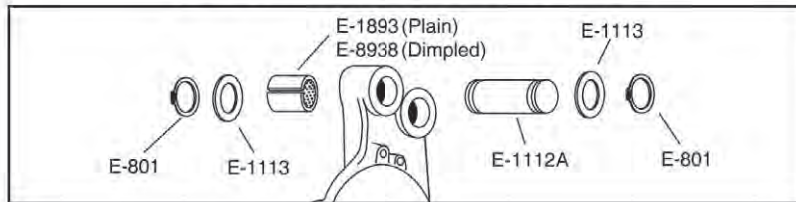

PartPage

E-747 1-151
 E-1580 1-177
 E-1581 1-177
 E-1582 1-177
 E-1583 1-177

SHOES, ROLLER AND SPRING

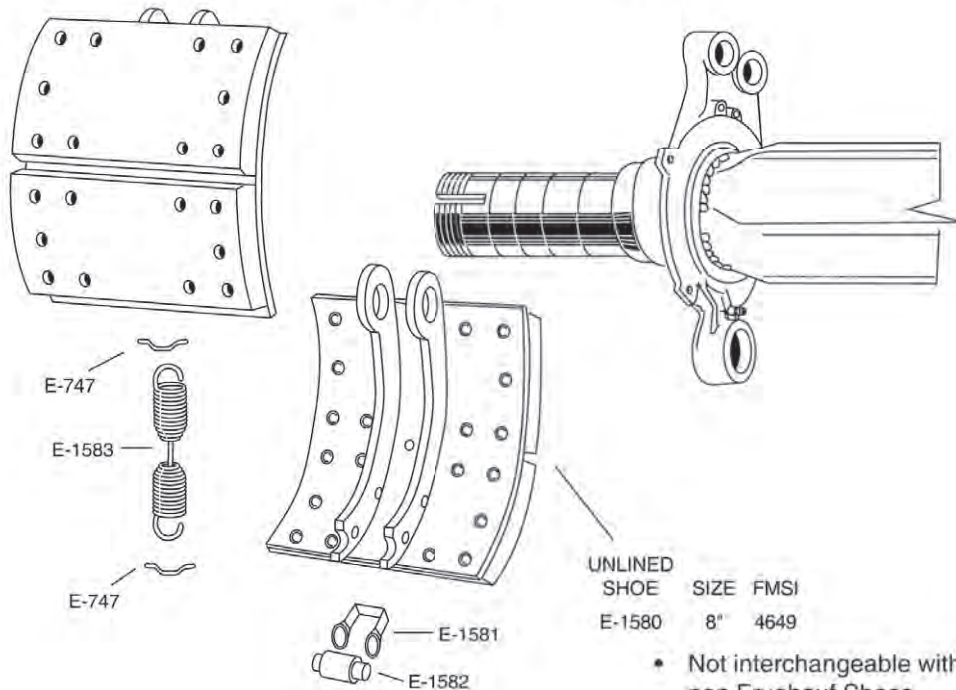

• Not interchangeable with non Fruehauf Shoes

PARTS FOR FRUEHAUF "PRO-PAR" TRAILER AXLE WITH 16 1/2" DIAMETER BRAKES

HUB CAPS, SPINDLE NUTS, SEALS & STUDS

Part	
E-04000	
E-04075	See catalog
E-04075H	100WE for
E-05500	component
E-1559	details
E-1561	
E-2550	

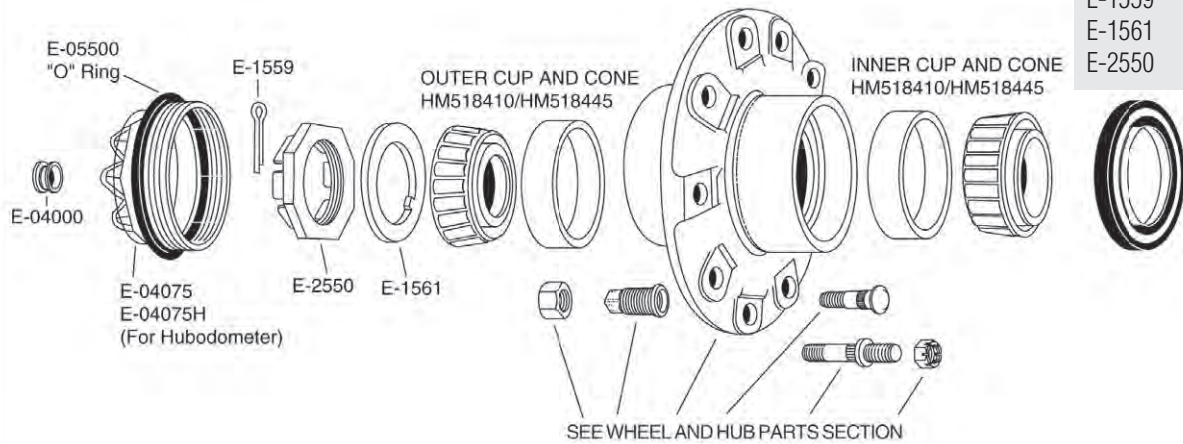

CAMSHAFT, BUSHINGS AND BRACKET PARTS

Part	Page
E-526	1-262
E-580	1-256
E-1565	1-257
E-1567	1-247
E-1569	1-262
E-1571	1-246
E-1577A	1-246
E-2090	1-224
E-4586	1-238
E-4587	1-238
E-4594	1-238

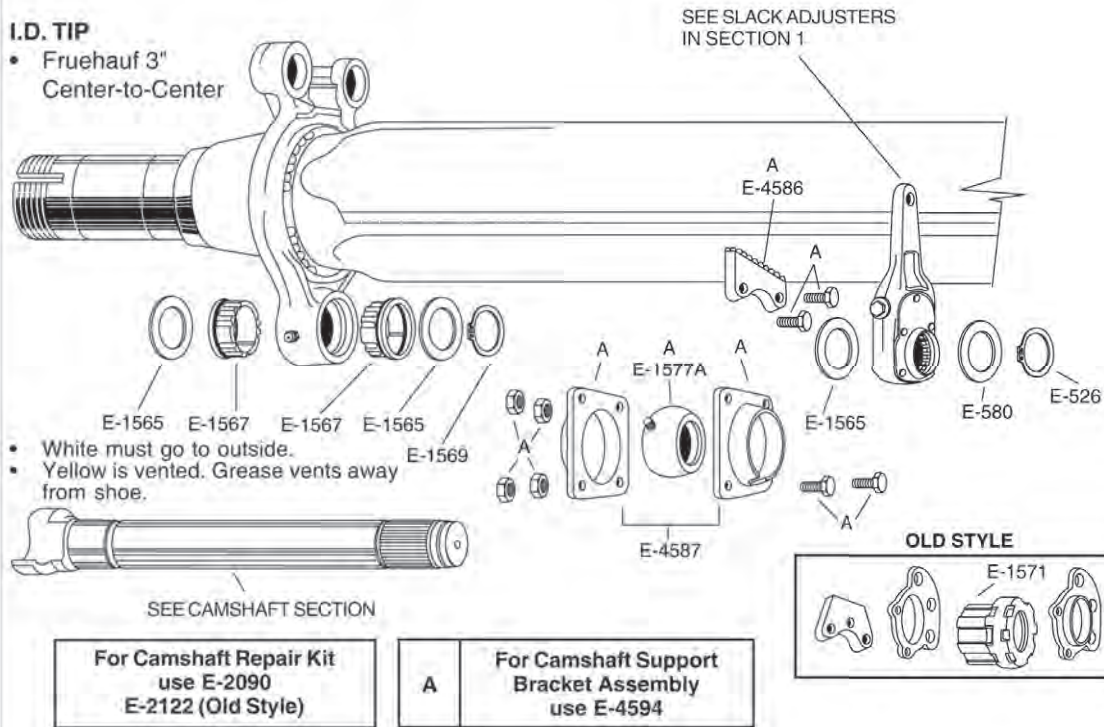

PARTS FOR FRUEHAUF "PRO-PAR" TRAILER AXLE WITH 16 1/2" DIAMETER BRAKES

PartPage
 KIT-5..... 1-98
 E-801..... 1-131
 E-920..... 1-140
 E-1112A..... 1-125
 E-1113..... 1-137
 E-1816HD.... 1-113
 E-1816S..... 1-111
 E-1816SHD.. 1-112
 E-1893..... 1-139
 E-2121..... 1-93
 E-2121HD.... 1-94
 E-2773..... 1-124
 E-2778..... 1-162

PartPage
 E-3710HD..... 1-95
 E-3710S..... 1-96
 E-3710SHD.... 1-97
 E-3711..... 1-124
 E-3895S..... 1-109
 E-3895SHD.. 1-109
 E-4880S..... 1-94
 E-4880SHD.... 1-95
 E-6999S..... 1-103
 E-6999SHD.. 1-104
 E-8938..... 1-139
 E-9061..... 1-124
 E-9142..... 1-99

ANCHOR PIN HARDWARE

NEW "XEM" ANCHOR PIN HARDWARE

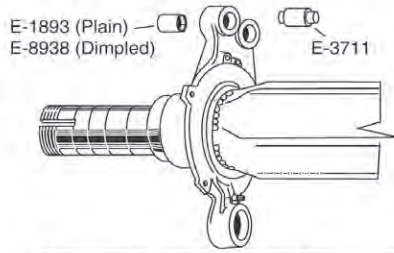

**For Brake Repair Kit
use E-3710HD, E-3710S
E-3710SHD, E-3895S, E-3895SHD,
E-6999S, E-6999SHD**

STD. ANCHOR PIN HARDWARE

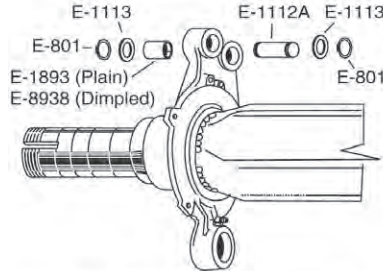

**For Brake Repair Kit
use E-1816HD, E-1816S,
E-1816SHD**

OLD STYLE "XEM" BRAKE



**Use Brake Repair Kit E-4880S,
E-4880SHD**

ECCENTRIC ANCHOR PIN BRAKE Uses Meritor "Q" Style Shoes

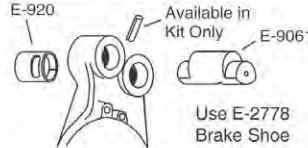

Use Brake Repair Kit E-9142

OLD STYLE ANCHOR PIN BRAKE



**Use Brake Repair Kit KIT-5,
E-2121 or E-2121HD**

SHOES, ROLLERS, SPRING & DUST SHIELD

PartPage
 E-523..... 1-117
 E-539..... 1-134
 E-545A..... 1-144
 E-747..... 1-151
 E-886..... 1-165
 E-1880B..... 1-145
 E-2177..... 1-116
 E-2685..... 1-160
 E-2767..... 1-150
 E-3227..... 1-134
 E-3228..... 1-145
 E-3490B..... 1-146
 E-3713..... 1-160
 E-3714..... 1-160
 E-3775..... 1-166
 E-3920..... 1-160

STD. BRAKE

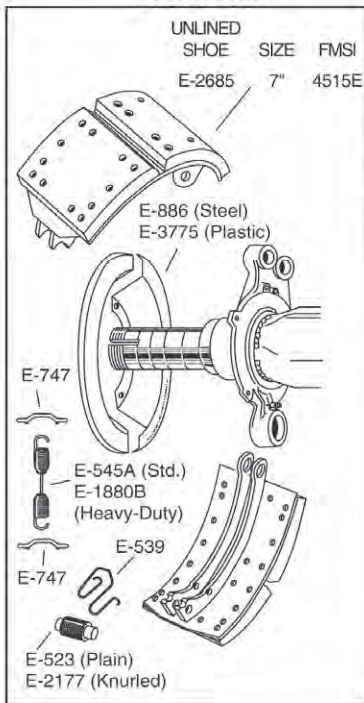

"XEM" BRAKE

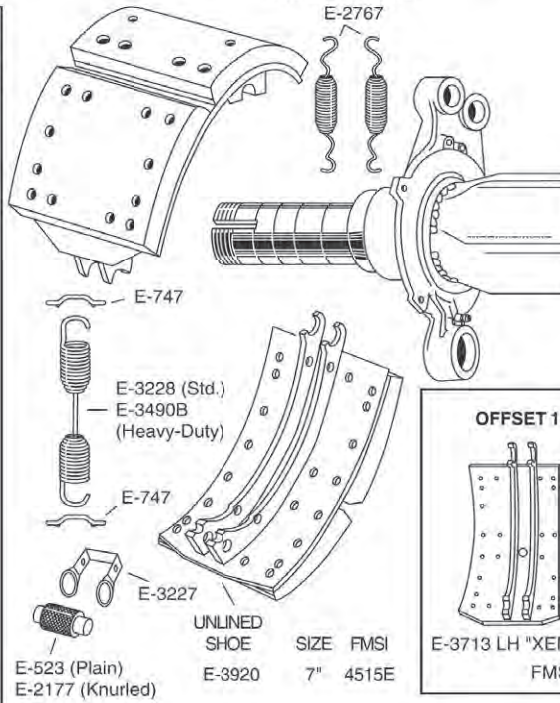

OFFSET 16 1/2" x 8 5/8"

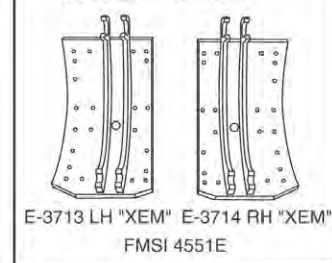

PARTS FOR HENDRICKSON INTRAAX® TRAILER AXLE WITH 16 1/2" DIAMETER BRAKES

BRAKE COMPONENTS

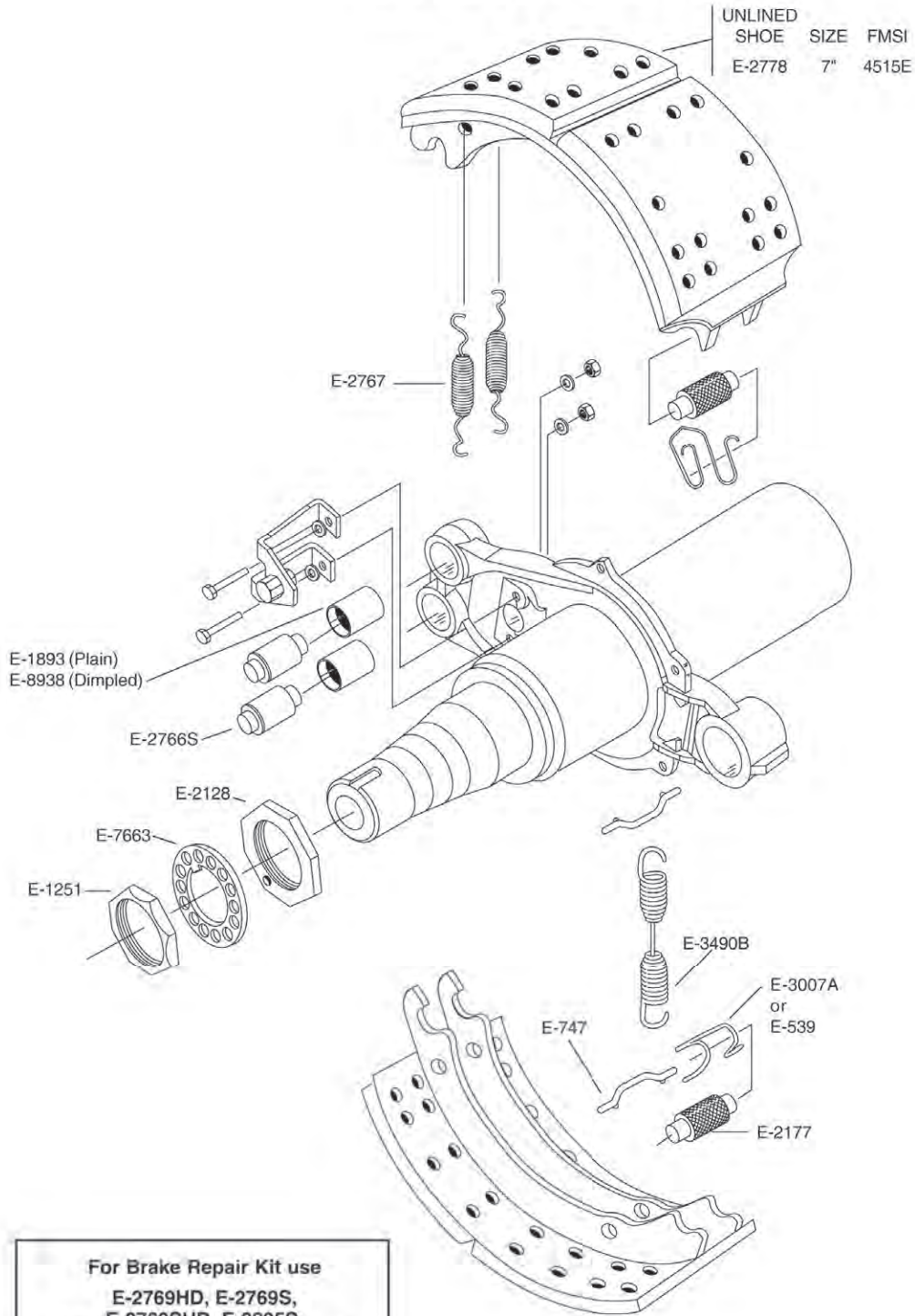

Part	Page
E-539	1-134
E-747	1-151
E-1893	1-139
E-2177	1-116
E-2766S	1-123
E-2767	1-150
E-2769HD	1-101
E-2769S	1-102
E-2769SHD	1-103
E-2778	1-162
E-3007A	1-133
E-3490B	1-146
E-3895S	1-109
E-3895SHD	1-109
E-6999S	1-103
E-6999SHD	1-104
E-8938	1-139

For Brake Repair Kit use
E-2769HD, E-2769S,
E-2769SHD, E-3895S,
E-3895SHD, E-6999S, E-6999SHD

PARTS FOR HENDRICKSON INTRAAX® TRAILER AXLE WITH 16 1/2" DIAMETER BRAKES

CAMSHAFT, BUSHINGS AND BRACKET PARTS OLD STYLE, EXPOSED CAM

Part	Page
E-656	1-260
E-719	1-257
E-807	1-244
E-1113	1-137
E-1318A	1-237
E-131AHD	1-237
E-1416	1-250
E-2720	1-261
E-4736	1-261
E-9791HD	1-234
E-11449	1-244
E-11450HD	1-220
E-114451	1-250

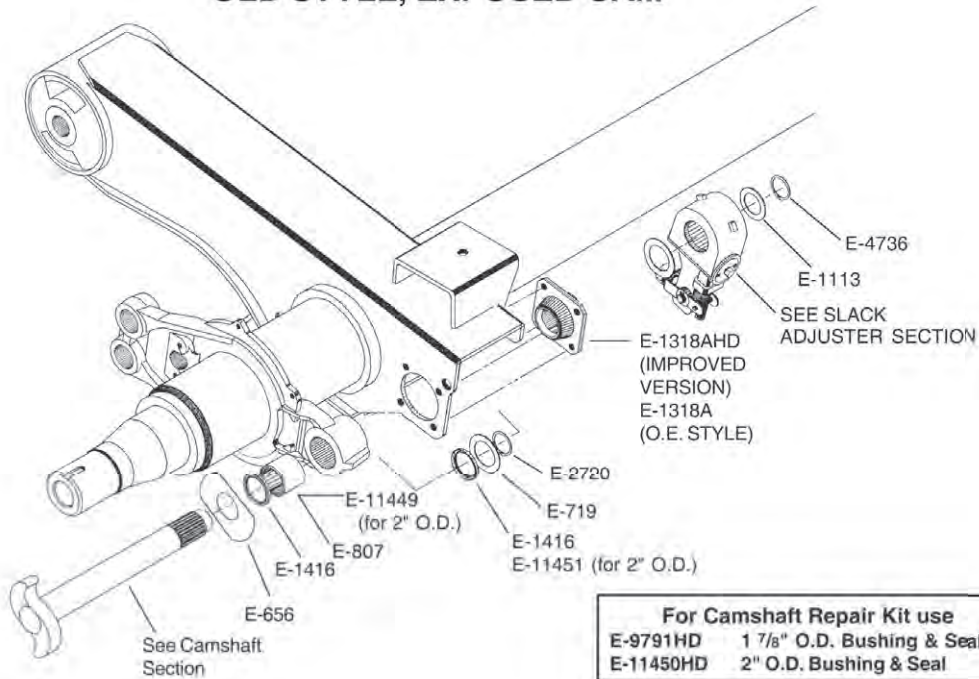

For Camshaft Repair Kit use
E-9791HD 1 7/8" O.D. Bushing & Seal
E-11450HD 2" O.D. Bushing & Seal

CAMSHAFT, BUSHINGS AND BRACKET PARTS NEW STYLE, ENCLOSED CAM TUBE

PAGE REFERENCE	
EUCLID NO.	PAGE NO.
E-11897	1-215

Part	Page
E-11897	1-221

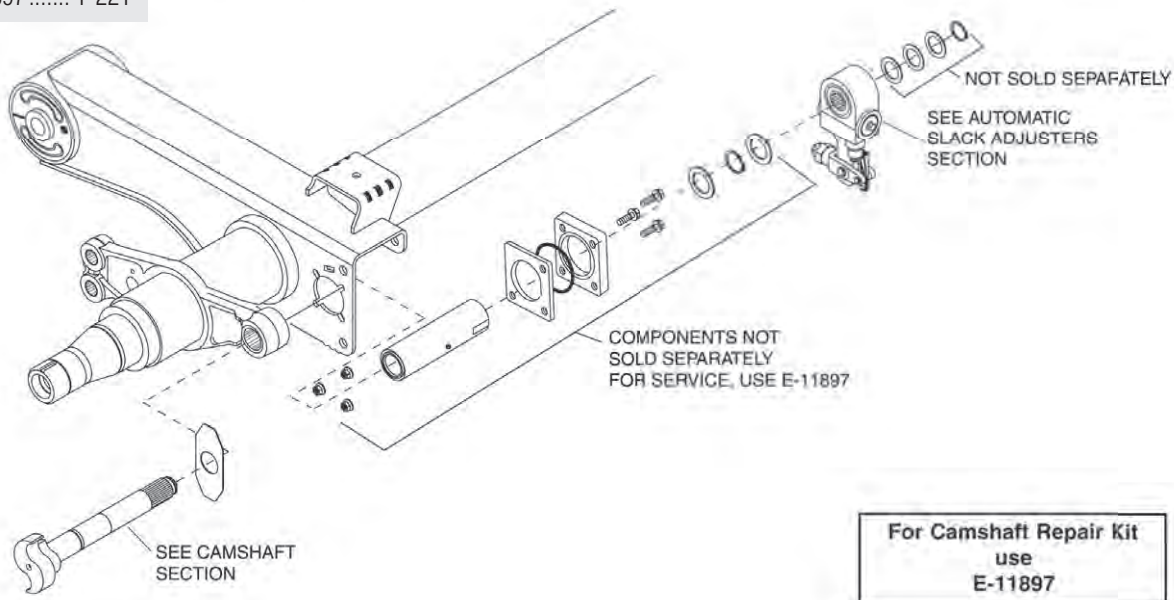

For Camshaft Repair Kit use
E-11897

MERITOR AIR DISC BRAKES

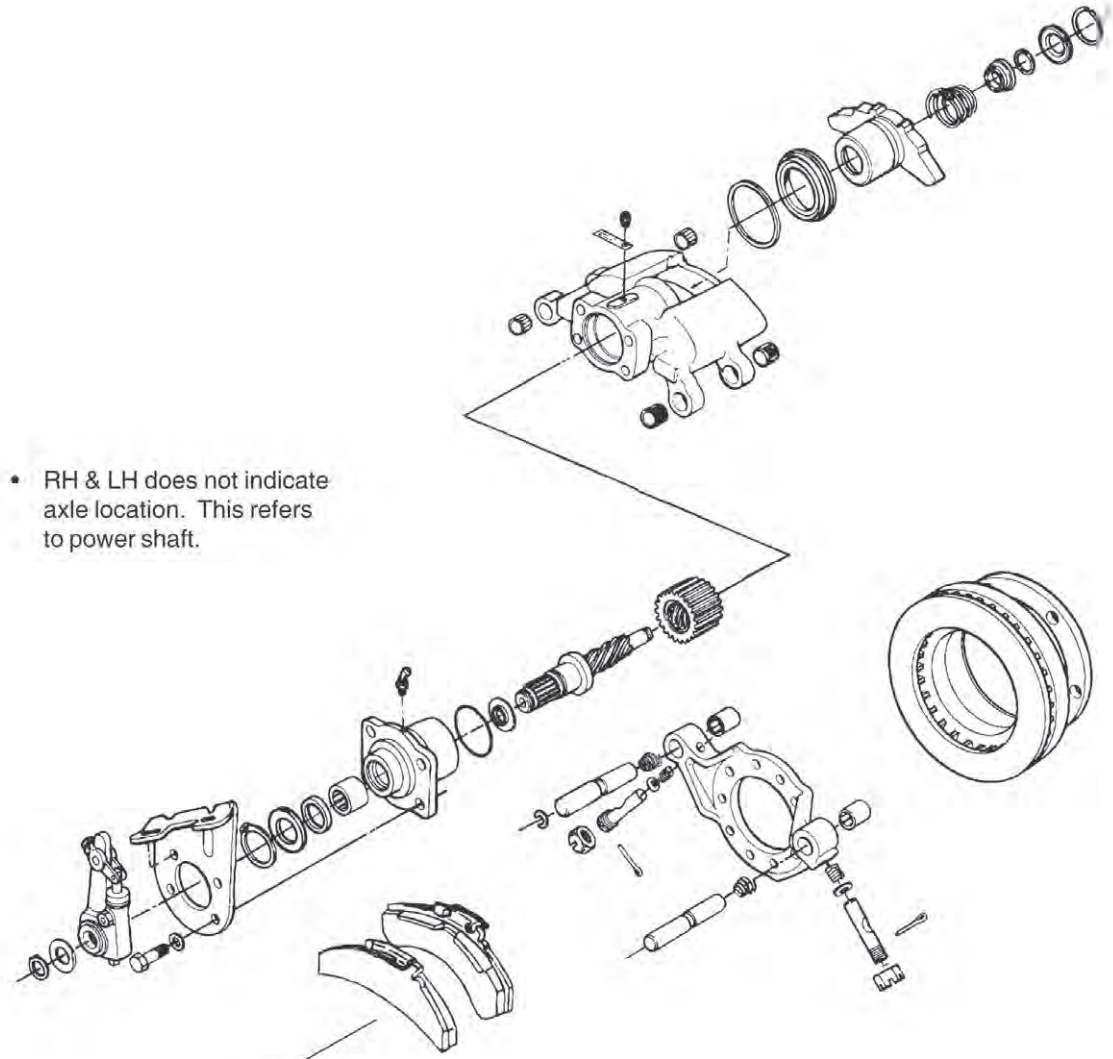

- RH & LH does not indicate axle location. This refers to power shaft.

E-D267	7172-D267
--------	-----------

I.D. TIP

- Rotor diameter identifies the brake series.

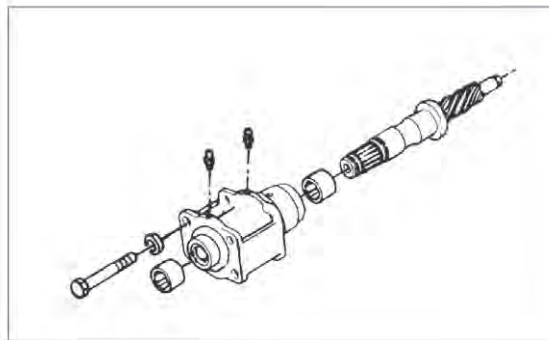

MERITOR 12 1/4" DIAMETER "Q" BRAKES

TRAILER AXLE BRAKE

Part Page

E-527 1-130
 E-747 1-151
 E-801 1-131
 E-1113 1-137
 E-1318A 1-237
 E-1318AHD.. 1-237
 E-1569 1-262
 E-1893 1-139
 E-2405 1-253
 E-2406 1-252
 E-2407 1-248
 E-2408 1-247
 E-2411A 1-256
 E-2766S 1-123
 E-2767 1-150
 E-3481A 1-142
 E-3482 1-122
 E-3483 1-120
 E-3484 1-75
 E-3520A 1-228
 E-3520AHD.. 1-229
 E-5093 1-261
 E-8938 1-139

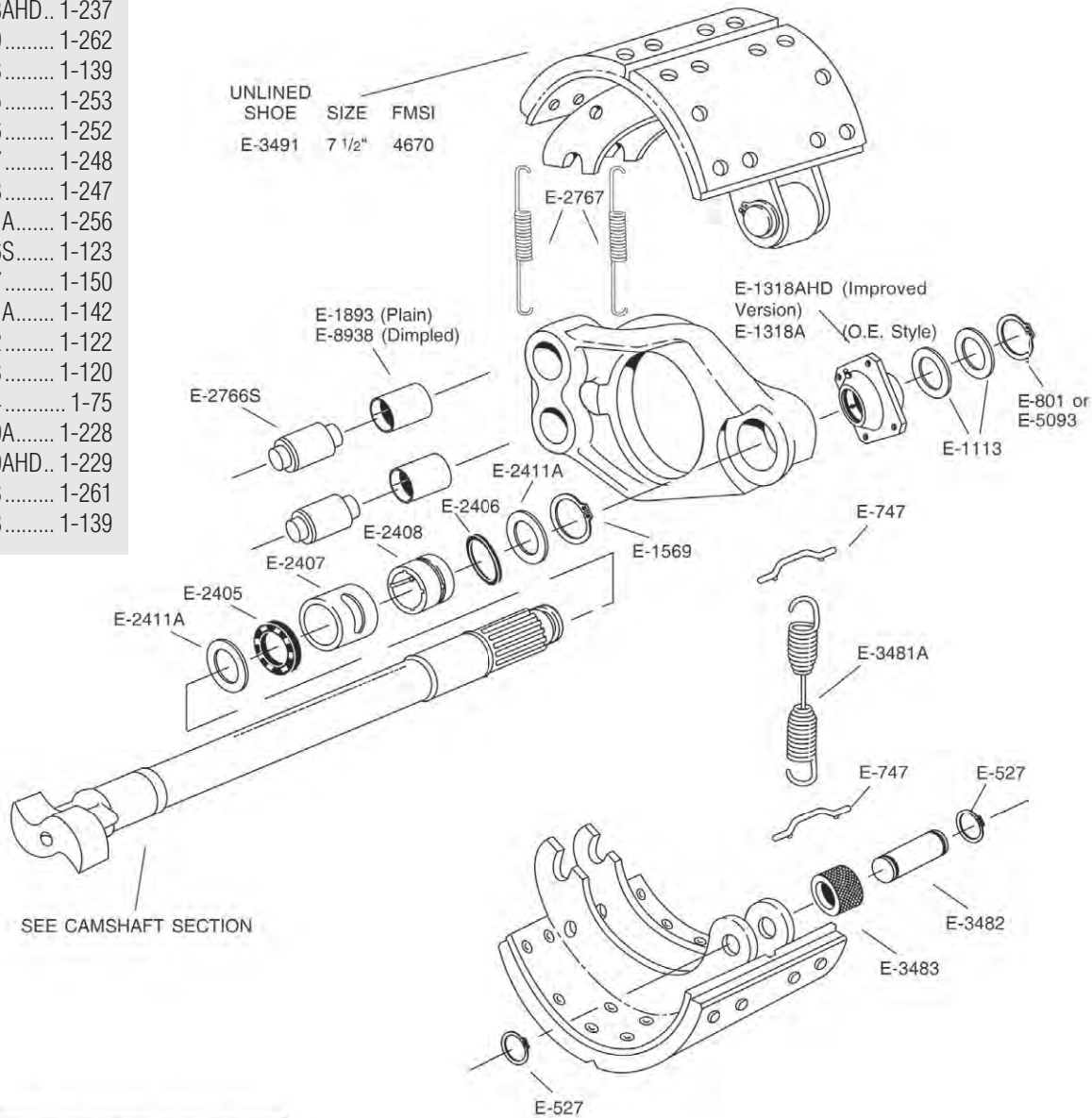

**For Brake Repair Kit
 use
 E-3484**

**For Camshaft Repair Kit use
 E-3520AHD (with Improved E-1318AHD)
 E-3520A (with O.E. Style E-1318A)**

STEER AXLE BRAKE

Part	Page
E-654	1-252
E-667	1-243
E-801	1-131
E-3479	1-257
E-4736	1-261
E-10811	1-152
E-10812	1-117
E-10813	1-138
E-10814	1-127
E-10816	1-136
E-10817	1-136
E-10818	1-142
E-10845	1-255

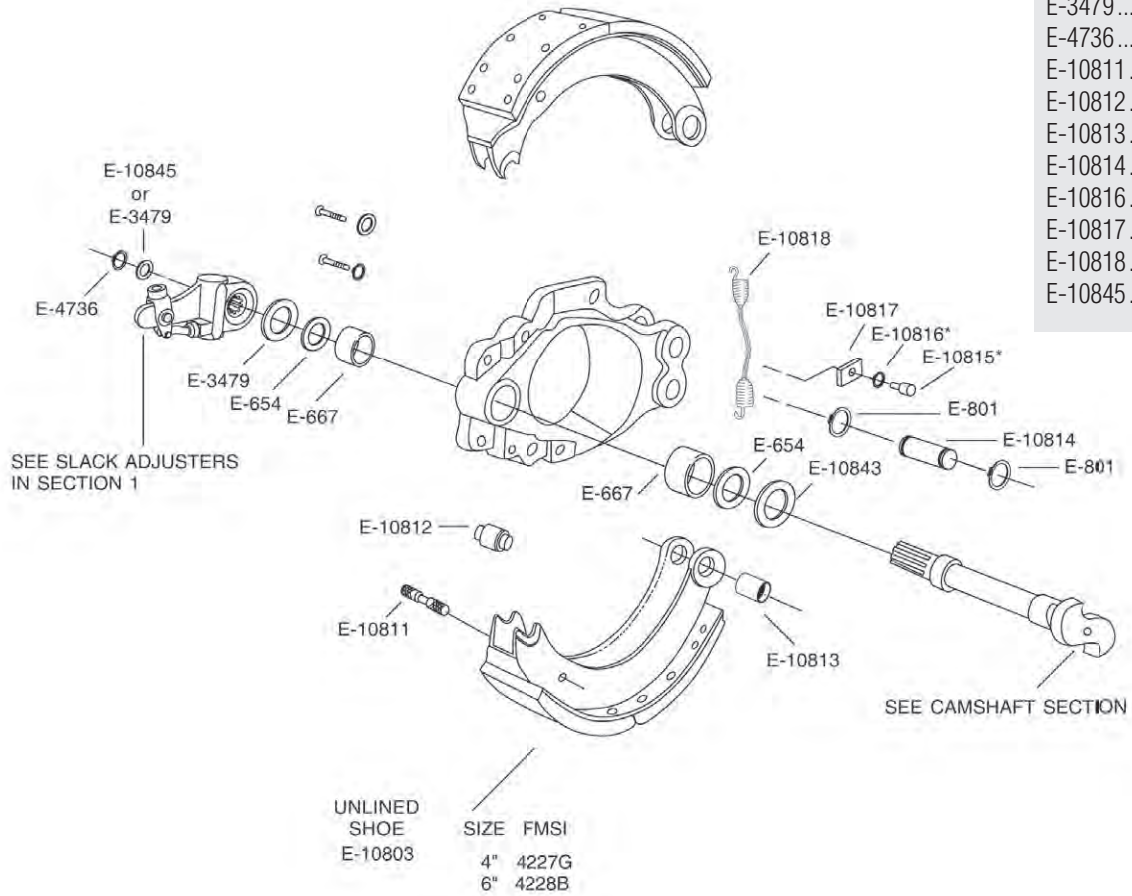

**For Brake Repair Kit
use
E-10841**

**For Camshaft Repair Kit
use
E-10846**

* Not Sold Separately

MERITOR 14 1/2" X 5" "W" SERIES

STEER AXLE COACH BRAKE

Part	Page	Part	Page
E-654	1-252	E-10814	1-127
E-667	1-243	E-10816	1-136
E-3479	1-257	E-10817	1-136
E-4736	1-261	E-10818	1-142
E-10811	1-152	E-10819	1-132
E-10812	1-117	E-10820	1-127
E-10813	1-138	E-10847	1-162

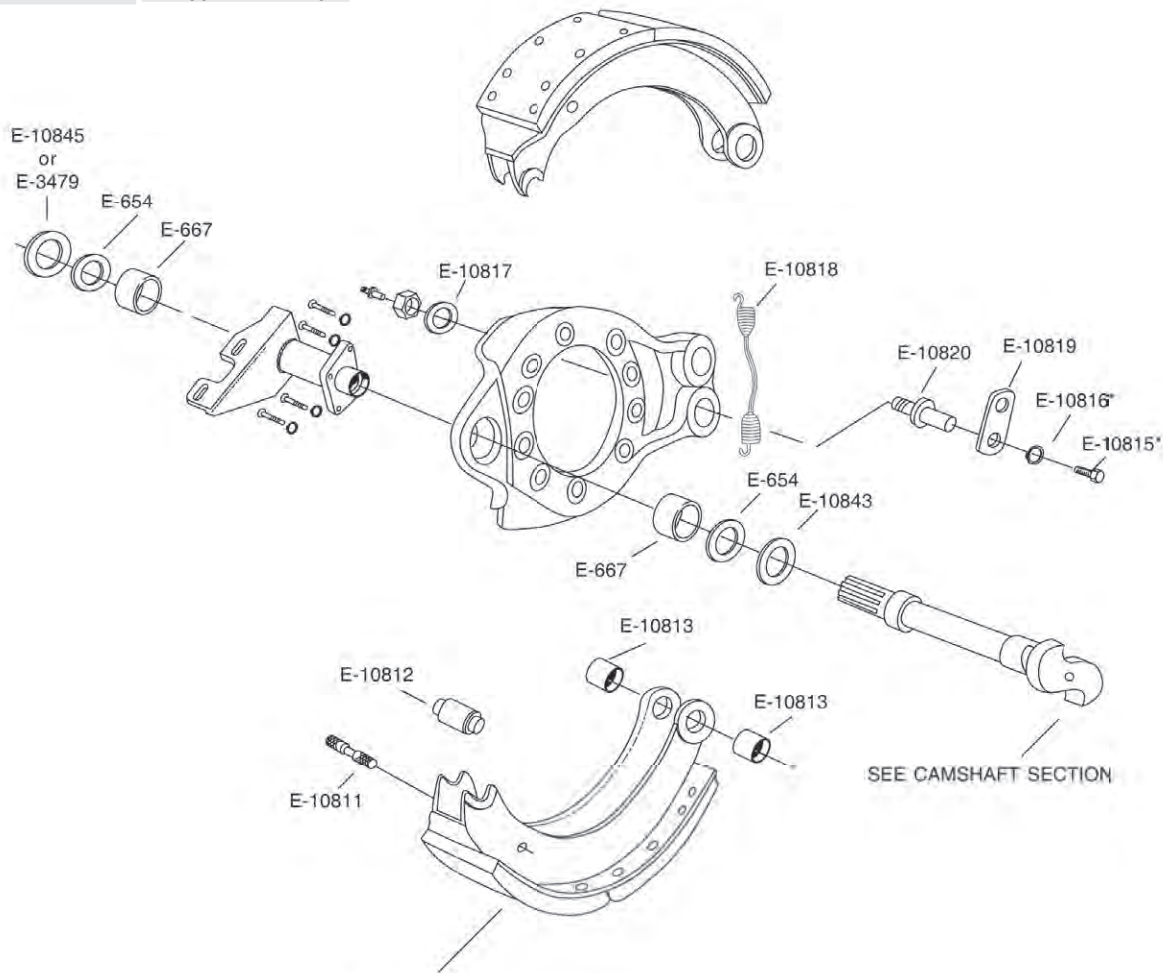

UNLINED SHOE	SIZE	FMSI
E-10804	5"	4398B

For Brake Repair Kit
use
E-10866A

For Camshaft Repair Kit
use
E-10846

* Not Sold Separately

MERITOR 14 1/2" X 8" & 10" "W" SERIES

DRIVE AXLE COACH BRAKE - TYPE 1

I.D. TIP

- Spring unique to Meritor 14 1/2" x 8" & 10" Brake

Part	Page
E-667	1-243
E-1835 . Cat 100WE	
E-3479	1-257
E-4961A	1-132
E-10813	1-138
E-10817	1-136
E-10823	1-118
E-10824	1-118
E-10825	1-127
E-10826	1-142
E-10829	1-132
E-10843	1-259
E-10845	1-255
E-10848	1-252
E-10849	1-253
E-10851	1-153

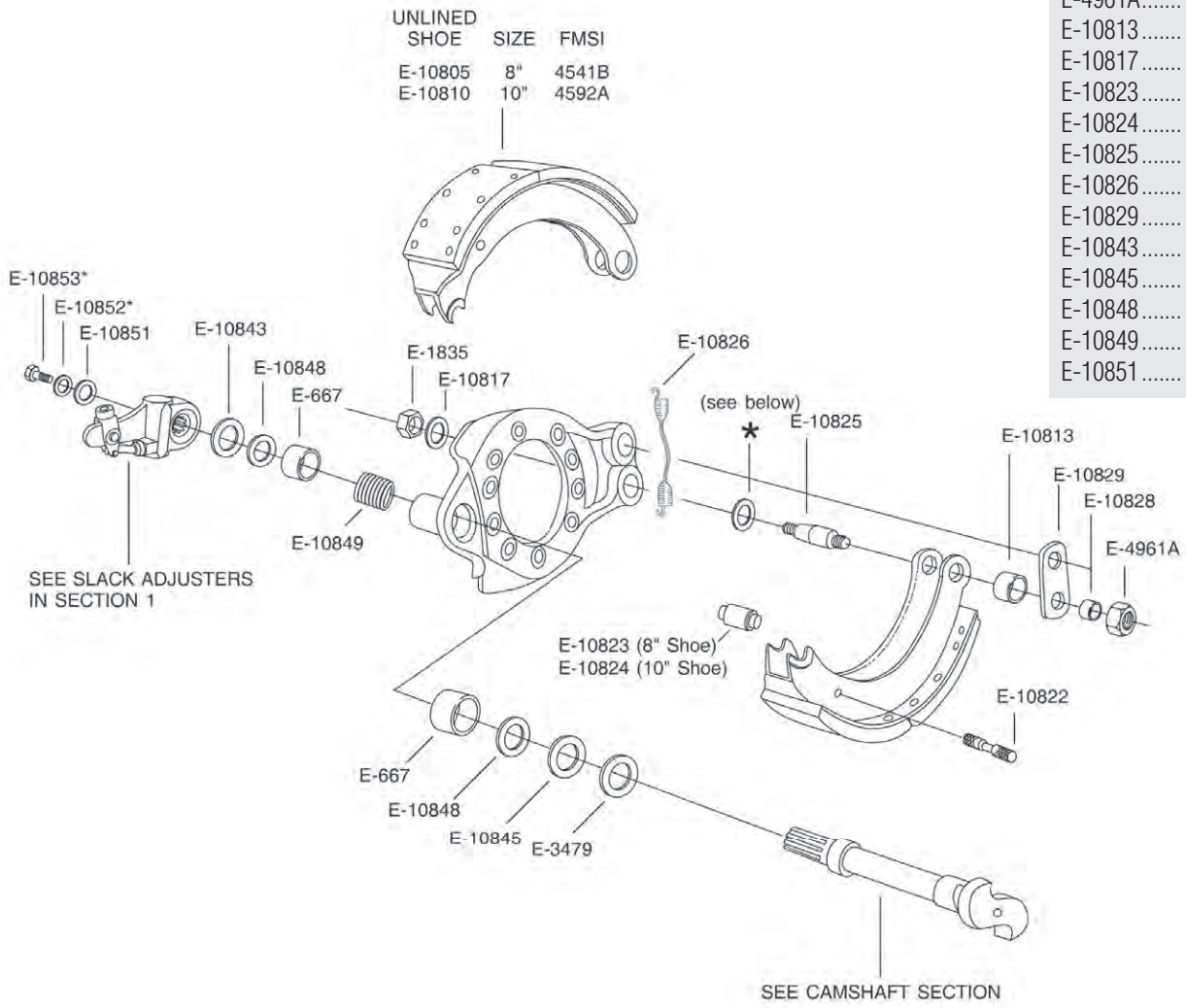

For Brake Repair Kit use
 8" Shoe E-10867
 10" Shoe E-10869

For Camshaft Repair Kit use
 E-10868

*PART NUMBERS	THICKNESS
E-5095	1/32"
E-1113	1/16"
E-10831	3/32"
E-10832	1/8"
E-10833	5/32"

* Not Sold Separately

MERITOR 14 1/2" X 10" "W" SERIES

DRIVE AXLE COACH BRAKE - TYPE 2

Part	Page	Part	Page
E-654	1-252	E-10838	1-118
E-667	1-243	E-10839	1-138
E-10809	1-157	E-10843	1-259
E-10822	1-151	E-10848	1-252
E-10826	1-142	E-10851	1-253
E-10834	1-131	E-10854	1-162
E-10835	1-127	E-10857	1-259
E-10836	1-140		

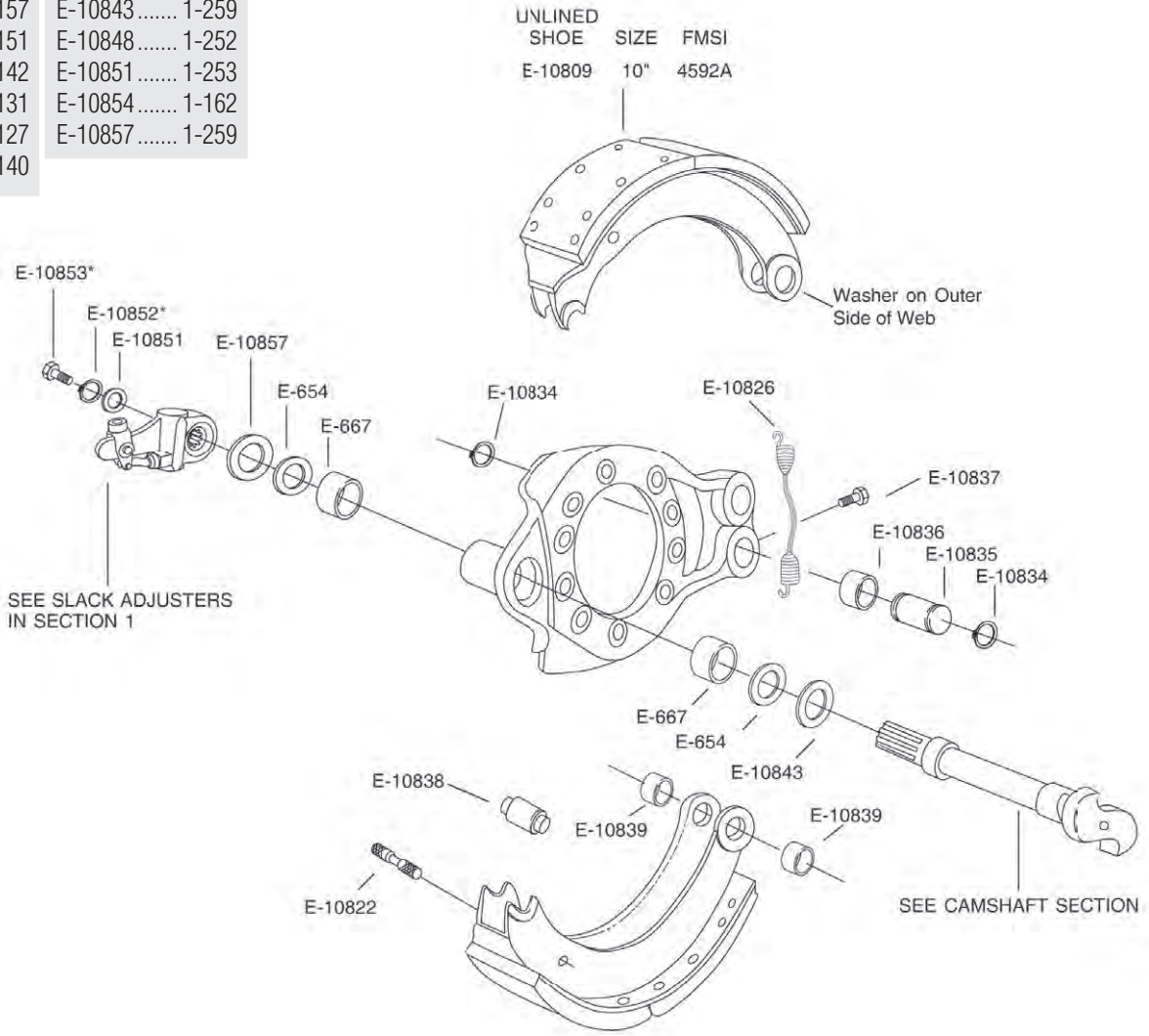

**For Brake Repair Kit
use
E-10870**

**For Camshaft Repair Kit
use
E-10871**

* Not Sold Separately

MERITOR 14 1/2" X 10" "W" SERIES

DRIVE AXLE COACH BRAKE - TYPE 3

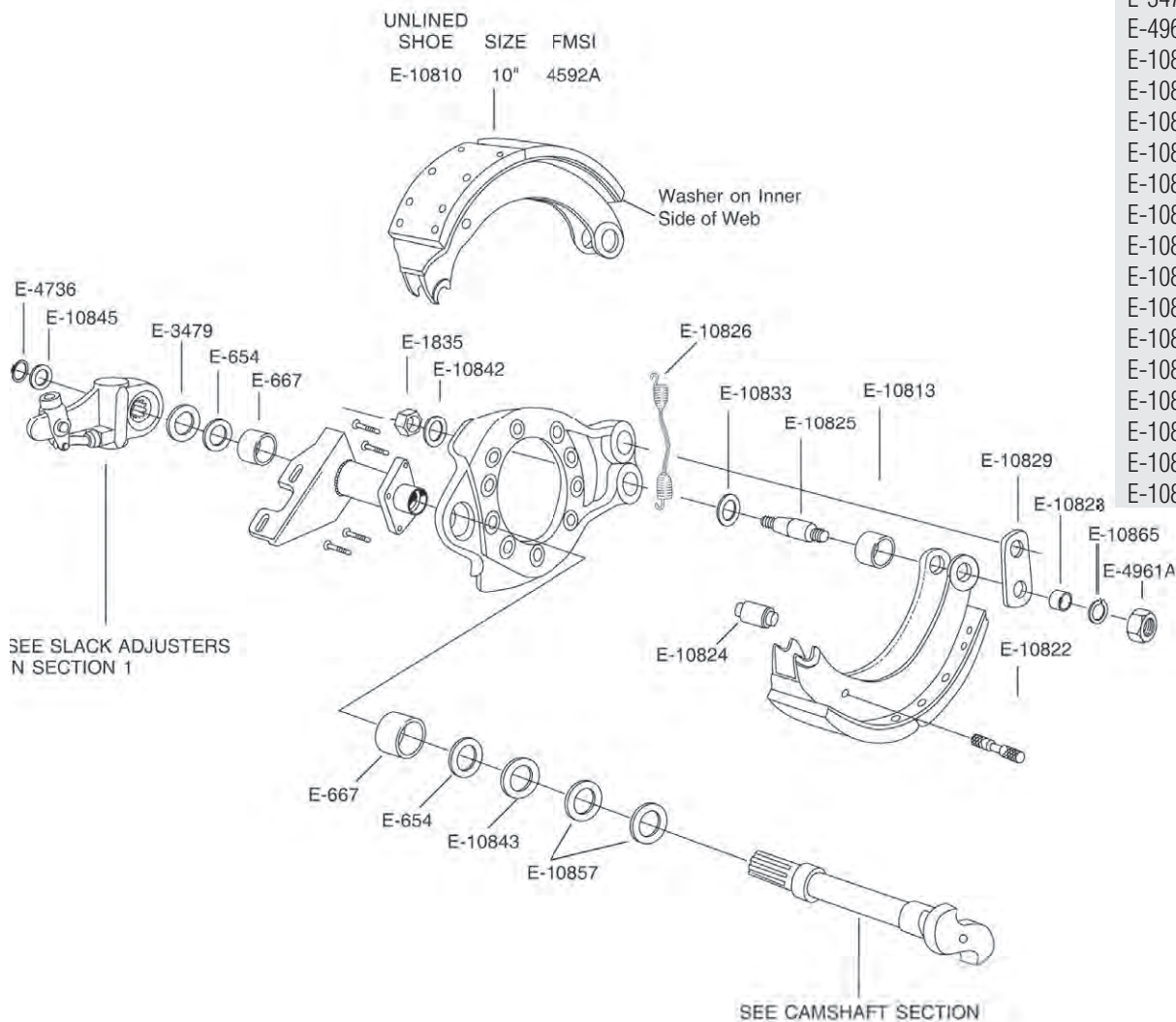

Part	Page
E-654	1-252
E-667	1-243
E-1835 . Cat 100WE	
E-3479	1-257
E-4961A	1-261
E-10813	1-132
E-10822	1-138
E-10824	1-151
E-10825	1-118
E-10826	1-127
E-10828	1-142
E-10829	1-140
E-10833	1-132
E-10842	1-137
E-10843	1-259
E-10845	1-255
E-10846	1-213
E-10847	1-162
E-10857	1-259
E-10865	1-136

**For Brake Repair Kit
use
E-10869**

**For Camshaft Repair Kit
use
E-10872**

MERITOR 15" DIAMETER "Q" SERIES

STEER AXLE BRAKE

Part	Page
E-2522	1-305
E-3421A	1-118
E-3476	1-257
E-3869	1-82
E-3870	1-128
E-3871	1-132
E-3872	1-143
E-3873	1-150
E-3874	1-136
E-3876	1-218
E-3877	1-241
E-3878	1-250
E-4961A	1-132
E-5528	1-158
E-7899	1-83
E-9076	1-260

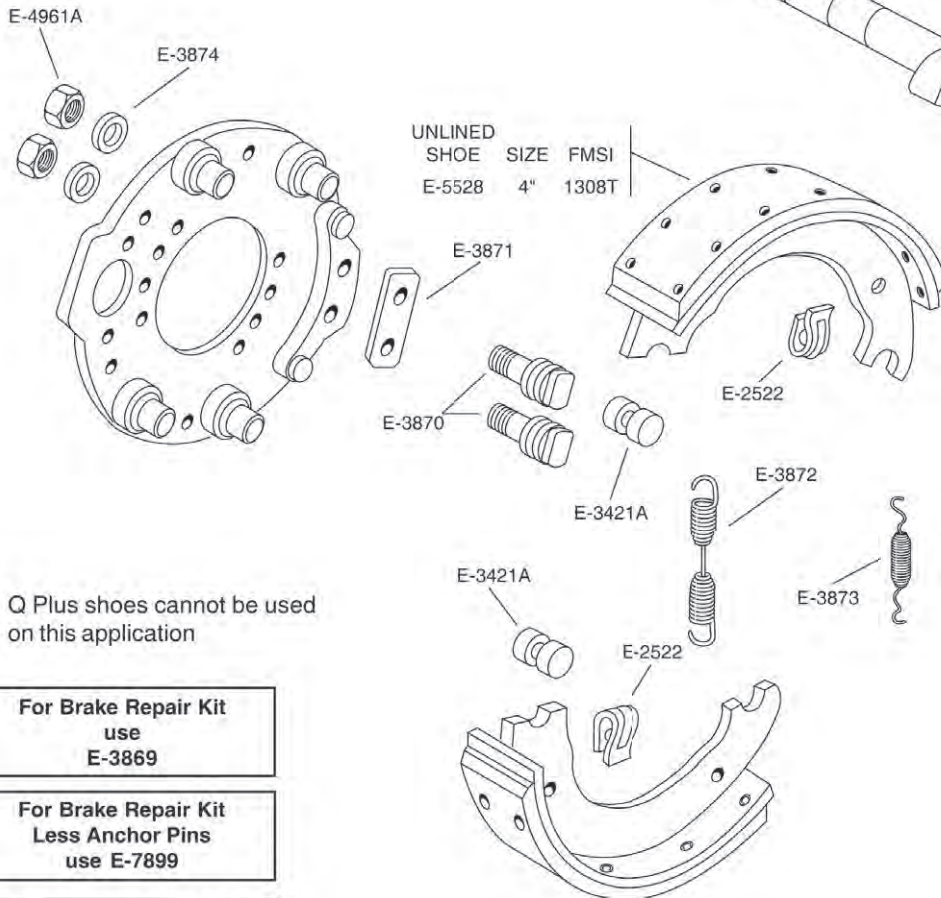
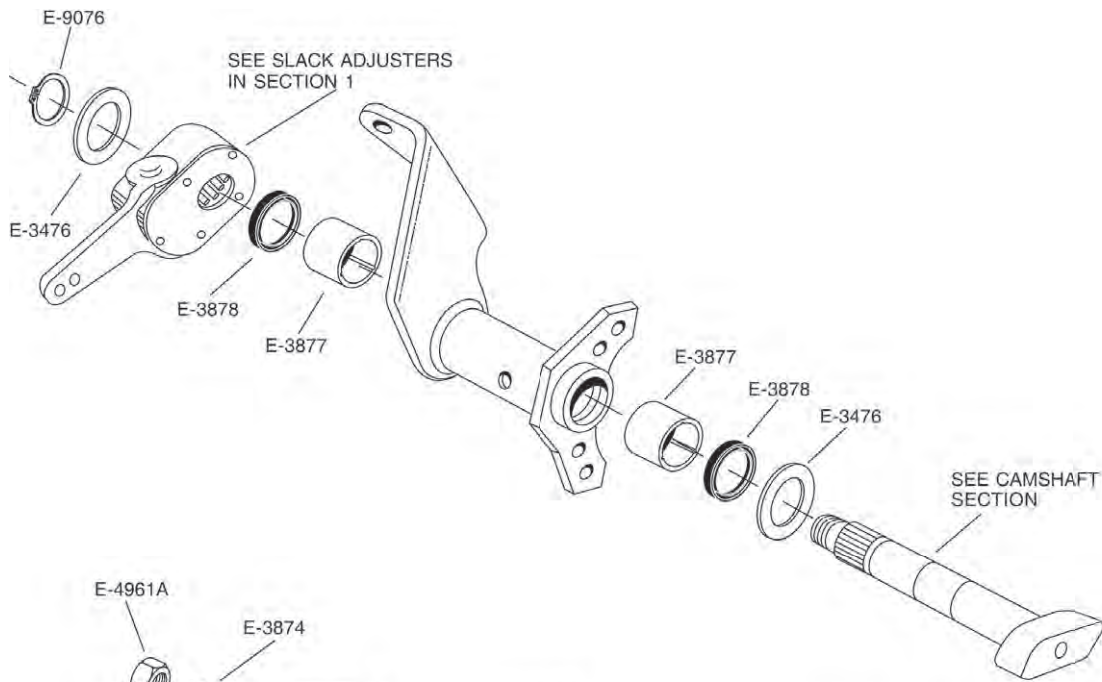

- Q Plus shoes cannot be used on this application

**For Brake Repair Kit
use
E-3869**

**For Brake Repair Kit
Less Anchor Pins
use E-7899**

**For Camshaft Repair Kit
use
E-3876**

MERITOR 15" DIAMETER Q PLUS™ BRAKES

STEER AXLE BRAKE

Part	Page
E-539	1-134
E-654	1-252
E-747	1-151
E-1893	1-139
E-2177	1-116
E-2766S	1-123
E-2767	1-150
E-3007A	1-133
E-3478	1-258
E-3479	1-257
E-3859	1-253
E-3993B	1-214
E-5093	1-261
E-5512	1-242
E-5513	1-230
E-8938	1-139
E-9062	1-158
E-9063	1-143
E-9064	1-81

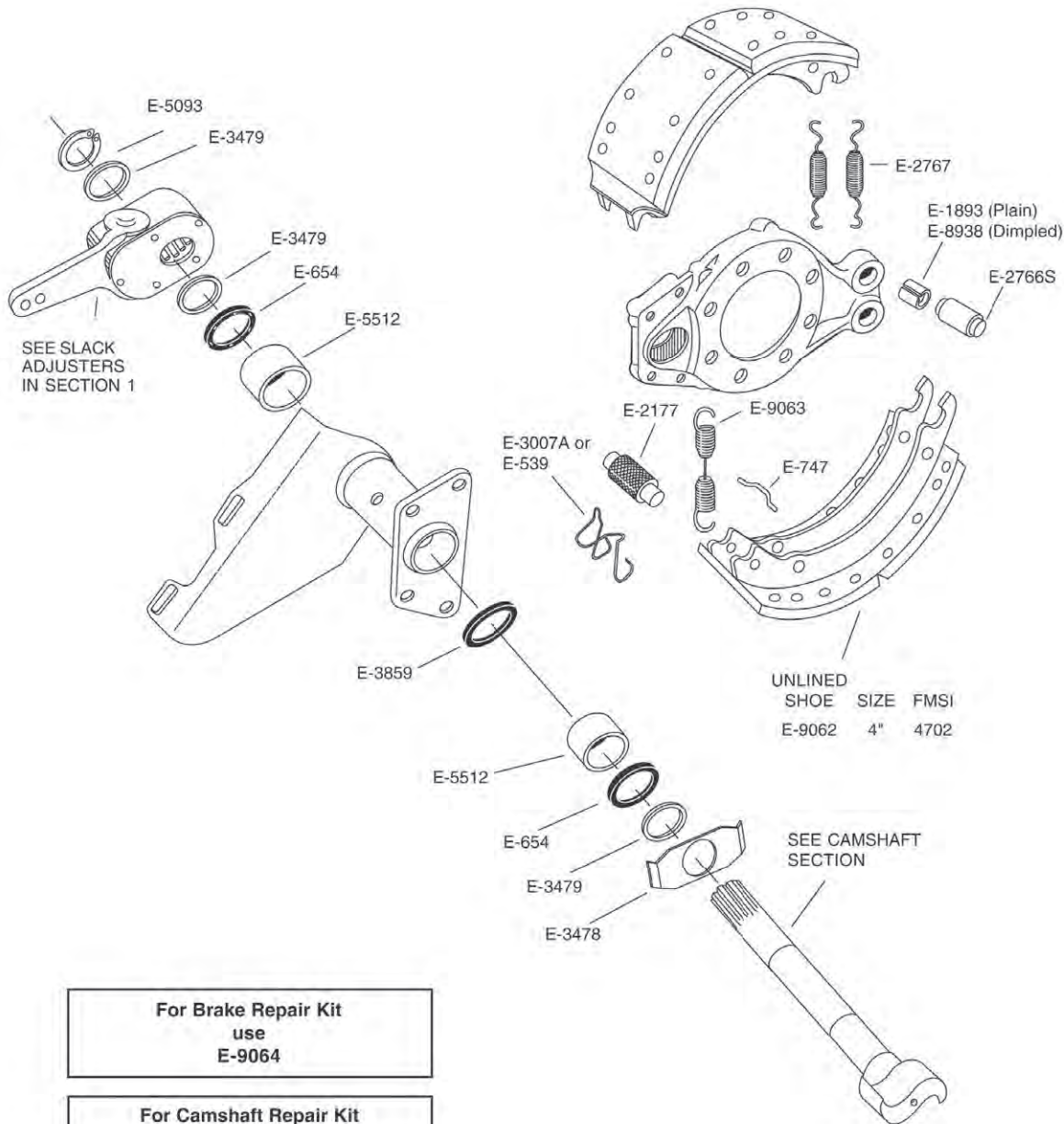

For Brake Repair Kit
use
E-9064

For Camshaft Repair Kit
use E-3993B or
E-5513 (Bushing and Seal Kit Only)

MERITOR "T" SERIES 15" DIAMETER BRAKES

STEER AXLE BRAKE with 1/2" dia. camshaft

PartPage

E-580	1-256
E-581	1-255
E-654	1-252
E-801	1-131
E-3421A	1-118
E-3427	1-137
E-3437	1-143
E-3438	1-158
E-3439	1-159
E-3468A	1-216
E-3473	1-258
E-4691	1-84
E-4736	1-261
E-4800	1-83
E-4961A	1-132
E-5512	1-242

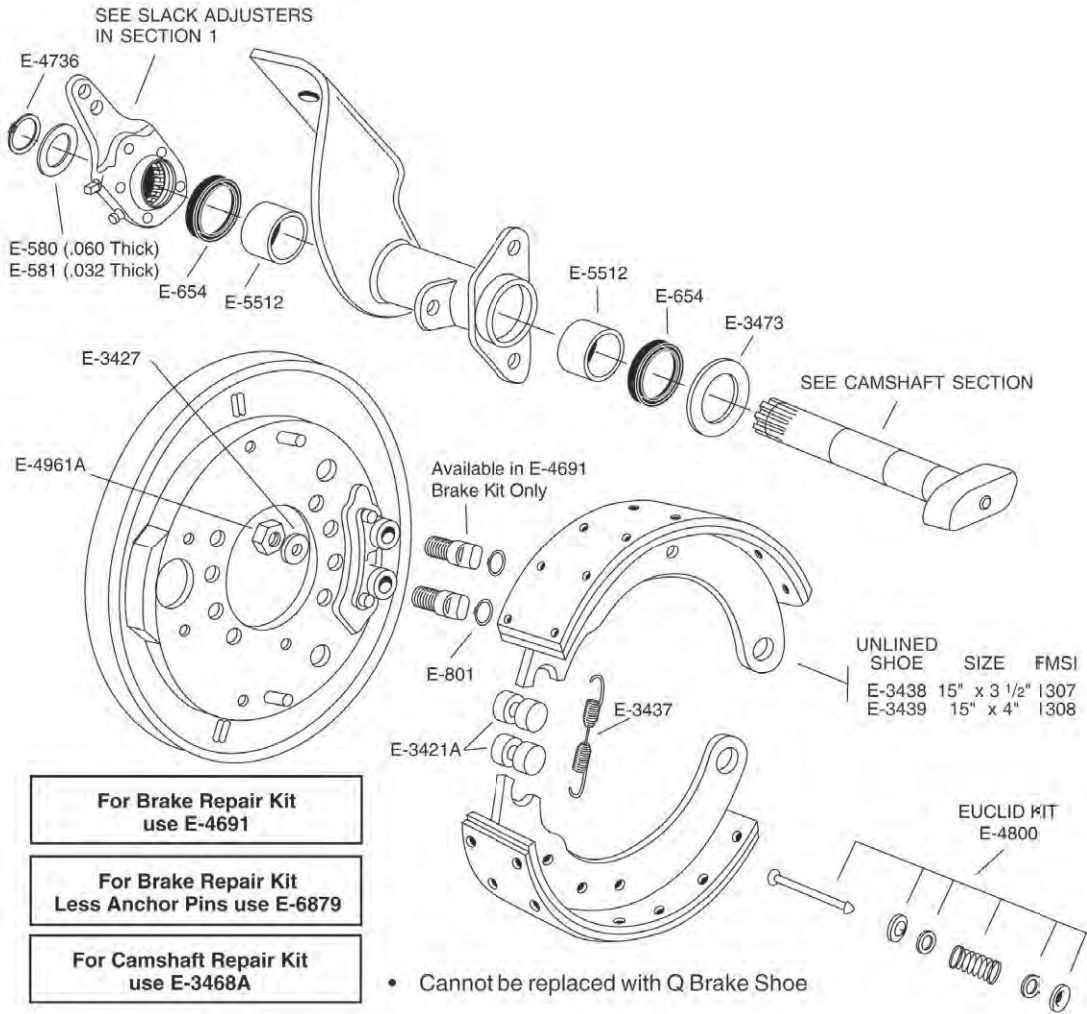

WITH 1 1/4" DIA. CAMSHAFT

PartPage

E-3446	1-217
E-3447	1-241
E-3469	1-250
E-3471	1-258
E-3474	1-253
E-3475	1-257
E-3476	1-257
E-5093	1-261

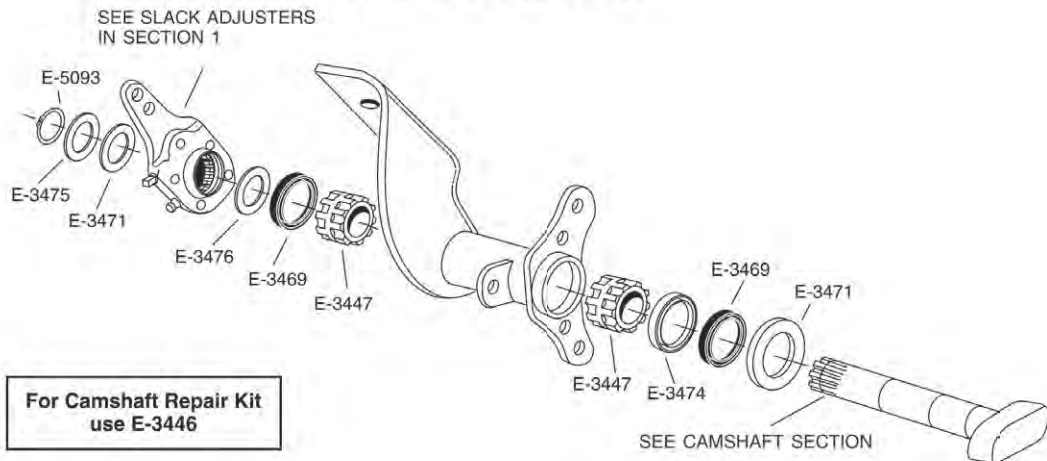

MERITOR "T" SERIES 16 1/4" DIAMETER BRAKES

STEER AXLE BRAKE

PartPage

E-580	1-256
E-581	1-255
E-654	1-252
E-1106	1-128
E-2522	1-305
E-3421A	1-118
E-3437	1-143
E-3441	1-159
E-3445	1-128
E-3468A	1-216
E-3472	1-258
E-4692	1-86
E-4736	1-261
E-5512	1-242

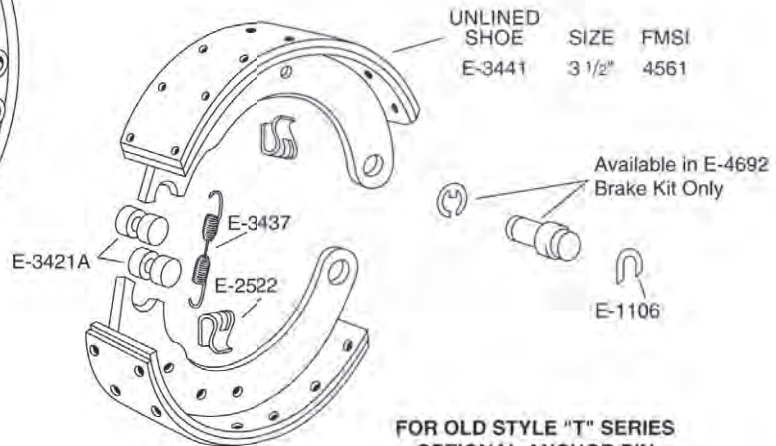
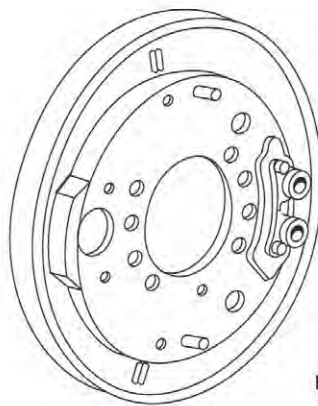
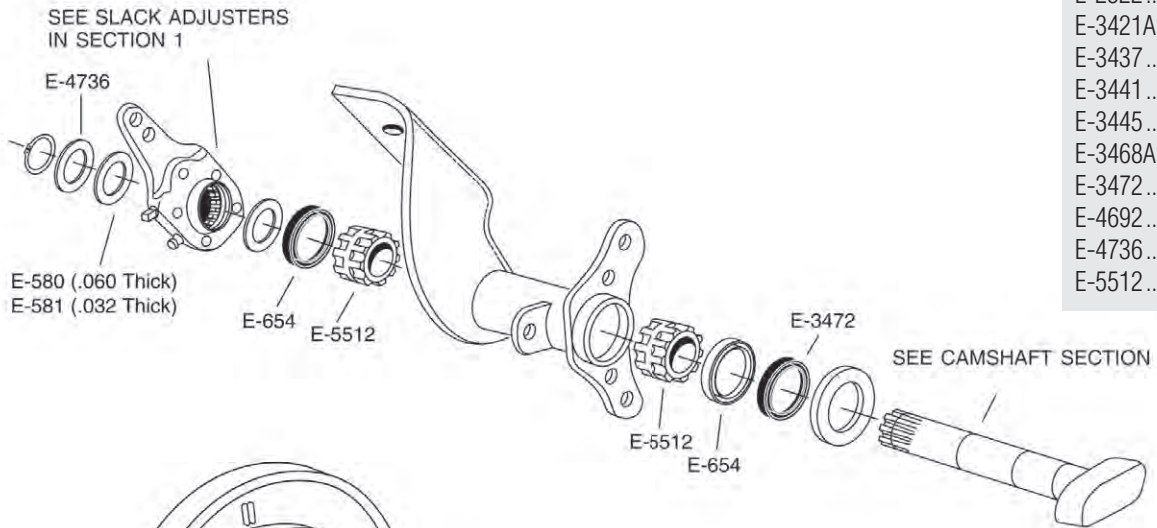

**FOR OLD STYLE "T" SERIES
OPTIONAL ANCHOR PIN**

E-3445 - Eccentric Pin

**For Brake Repair Kit
use
E-4692**

**For Camshaft Repair Kit
use
E-3468A**

- Eccentric pin can be used to adjust lining to drum clearance.

MERITOR 16 1/2" DIAMETER "Q" AND "P" BRAKES

TRUCK AND TRACTOR BRAKE

PartPage

E-523.....	1-117
E-539.....	1-134
E-545A.....	1-144
E-654.....	1-252
E-747.....	1-151
E-801.....	1-131
E-112A.....	1-125
E-1113.....	1-137
E-1816HD....	1-113
E-1816S.....	1-111
E-816SHD....	1-112
E-1880B.....	1-145
E-1893.....	1-139
E-2086B.....	1-219
E-2177.....	1-116
E-2241.....	1-161
E-2684.....	1-161
E-2686.....	1-161
E-2687.....	1-161
E-2766S.....	1-123
E-2767.....	1-150
E-2768.....	1-141
E-2769HD....	1-101
E-2769S.....	1-102
E-2769SHD..	1-103
E-2778.....	1-162
E-3007A.....	1-133
E-3303.....	1-161
E-3304.....	1-161
E-3478.....	1-258
E-3479.....	1-257
E-3490B.....	1-146
E-3859.....	1-253
E-3895S.....	1-109
E-3895SHD..	1-109
E-3993B.....	1-214
E-5093.....	1-261
E-5512.....	1-242
E-5513.....	1-230
E-6999S.....	1-103
E-6999SHD..	1-104
E-8938.....	1-139

"Q" BRAKE

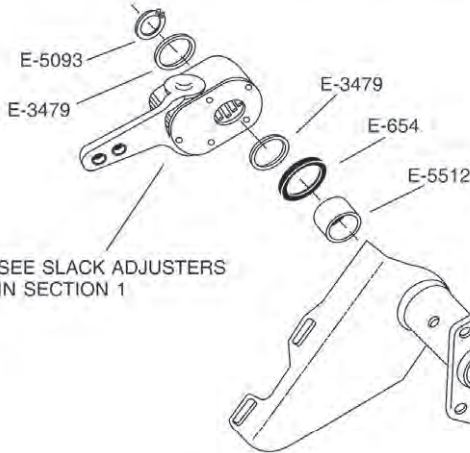

For "Q" Brake Repair Kit use

E-2769HD, E-2769S, E-2769SHD,
E-3895S, E-3895SHD, E-6999S,
E-6999SHD,

For "Q" Brake Camshaft
Repair Kit use E-3993B or
E-5513 (Bushing & Seal Kit Only)

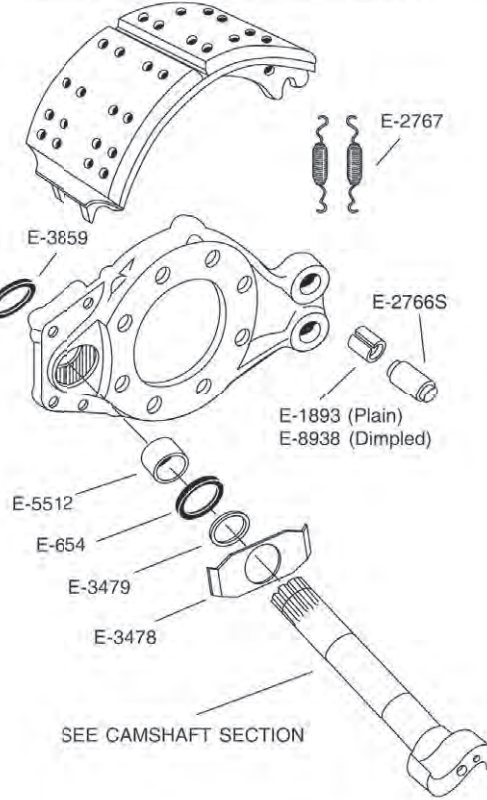

"P" BRAKE

	UNLINED SHOE	SIZE	FMSI
DRIVE AXLE	E-2684	6"	4514G
	E-2241	7"	4515E
STEERING AXLE	E-2686	4"	4549C
	E-2687	5"	4524B

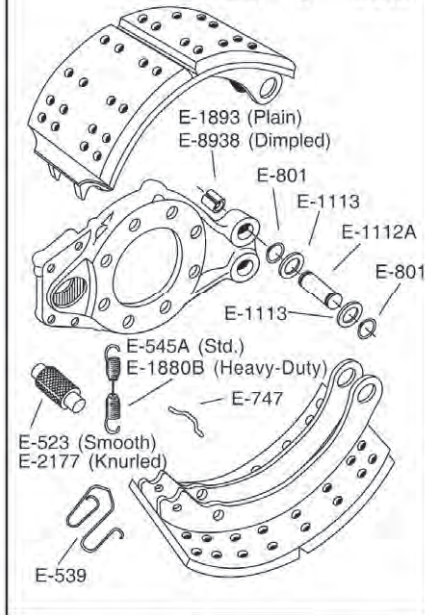

For "P" Brake Repair Kit
use
E-1816HD, E-1816S or E-1816SHD

For "P" Brake Camshaft
Repair Kit
use E-2086B

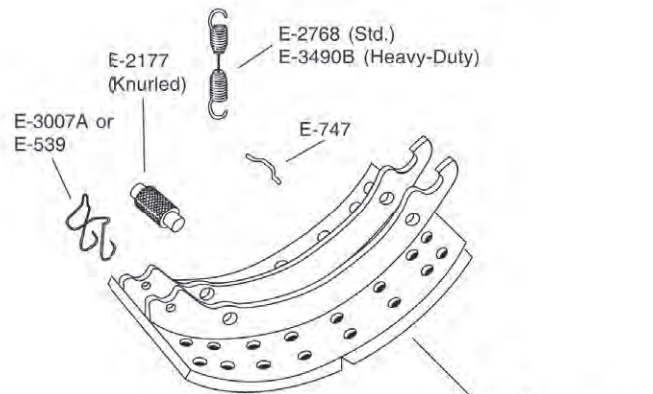

	UNLINED SHOE	SIZE	FMSI
STEERING AXLE	E-3303	5"	4524
DRIVE AXLE	E-2778	7"	4515
	E-3304	6"	4514

MERITOR 16 1/2" DIAMETER Q PLUS™ BRAKES

TRUCK AND TRACTOR BRAKE

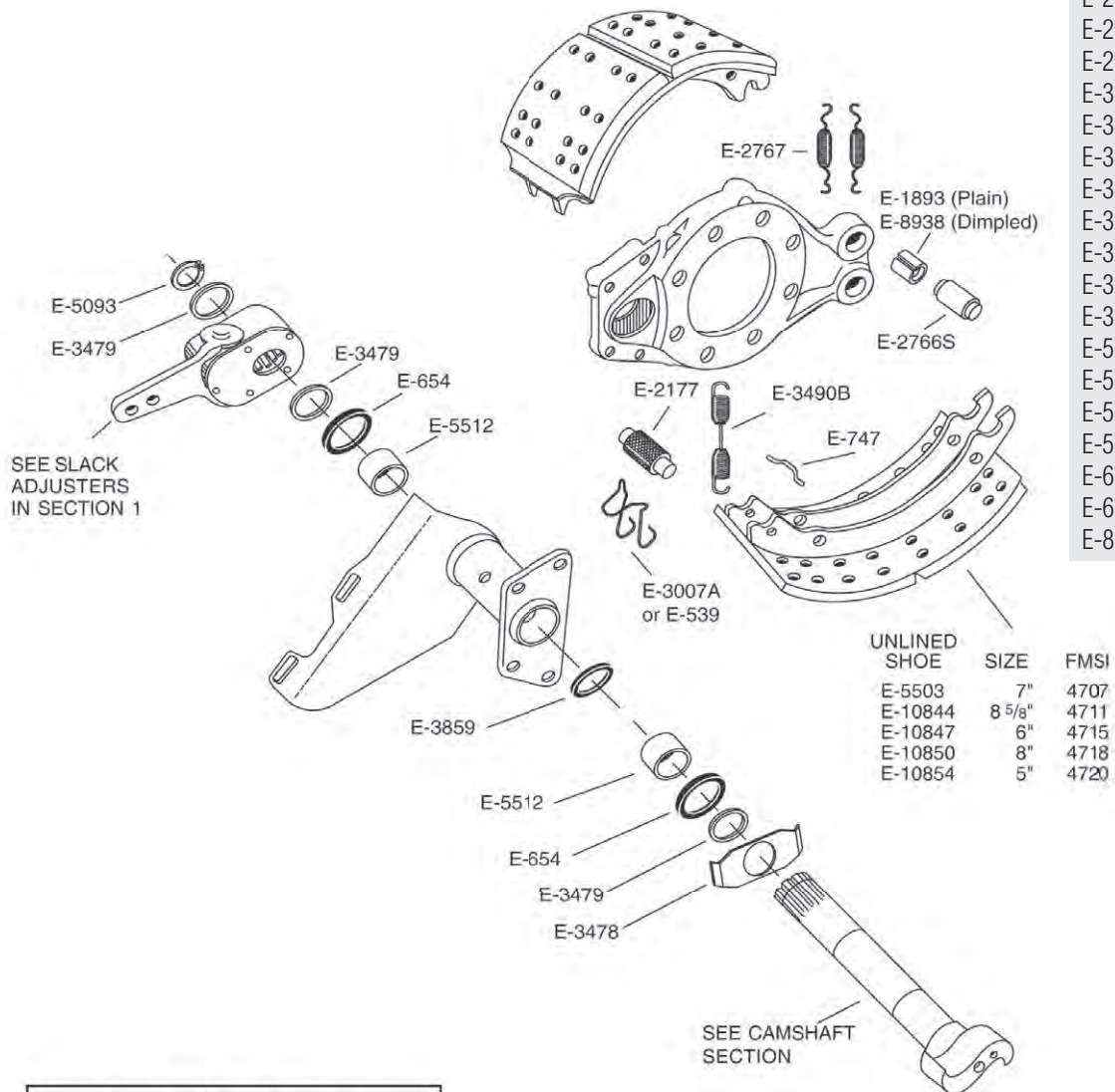

PartPage

E-539 1-134
 E-654 1-252
 E-747 1-151
 E-1893 1-139
 E-2177 1-116
 E-2768 1-141
 E-2767 1-150
 E-2769HD 1-101
 E-2769S..... 1-102
 E-2769SHD.. 1-103
 E-3007A..... 1-133
 E-3478 1-258
 E-3479 1-257
 E-3490B..... 1-146
 E-3859 1-253
 E-3895S..... 1-109
 E-3895SHD.. 1-109
 E-3993B..... 1-214
 E-5093 1-261
 E-5503 1-162
 E-5512 1-242
 E-5513 1-230
 E-6999S..... 1-103
 E-6999SHD.. 1-104
 E-8938 1-139

**For Brake Repair Kit use
 E-2769HD, E-2769S, E-2769SHD,
 E-3895S, E-3895SHD, E-6999S,
 E-6999SHD**

**For Camshaft Repair Kit
 use E-3993B or
 E-5513 (Bushing & Seal Kit Only)**

MERITOR 16 1/2" DIAMETER "Q" AND "P" BRAKES

FOR MACK TRUCK

with 44,000 lb. Rear

"Q" BRAKE

Part Page

E-502	1-126
E-526	1-262
E-530	1-138
E-539	1-134
E-564	1-255
E-654	1-252
E-656	1-260
E-801	1-131
E-919	1-140
E-961	1-241
E-1269	1-130
E-1307	1-139
E-1880B	1-145
E-1893	1-139
E-2086B	1-219
E-2177	1-116
E-2405	1-253
E-2522	1-305
E-2672	1-118
E-2675HD	1-106
E-2676	1-104
E-2766S	1-123
E-2767	1-150
E-3007A	1-133
E-3490B	1-146
E-3823	1-161
E-3854	1-180
E-3859	1-253
E-3914	1-116
E-5086	1-105
E-5088	1-150
E-5089	1-118
E-5092	1-161
E-5093	1-261
E-5512	1-242
E-8938	1-139
E-9643	1-146
E-9644	1-108

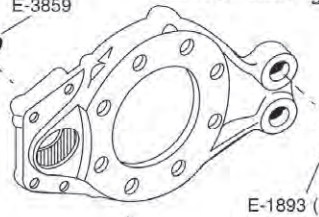
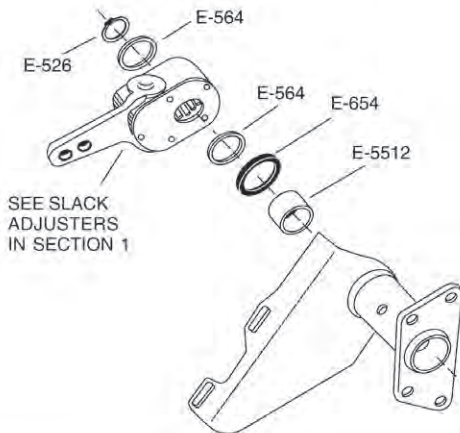

"P" BRAKE

UNLINED SHOE	SIZE	FMSI
N.A.	7"	4625B

For Brake Repair Kit use E-2675HD
For Camshaft Repair Kit use E-2086B

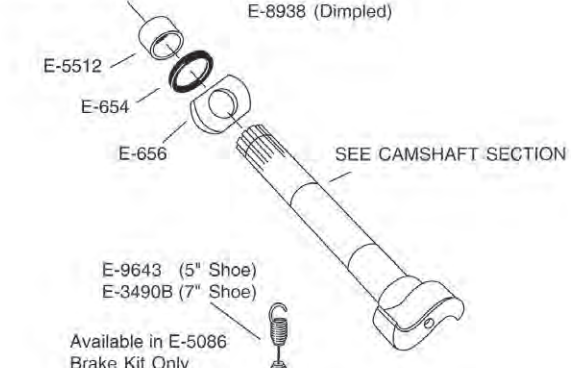

MACK BRAKE PRIOR TO 1970

Washers and Seals Available in E-2676 Brake Kit Only

For Brake Repair Kit use E-2676

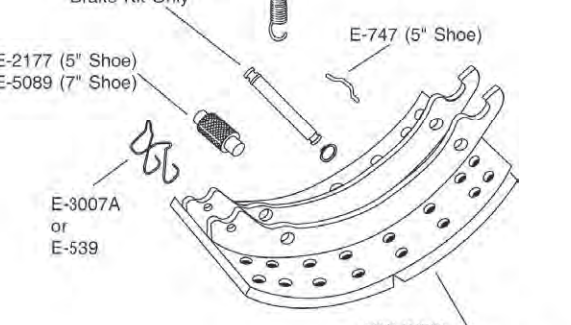

	UNLINED SHOE	SIZE	FMSI
STEERING AXLE	E-3823	5"	4524B
DRIVE AXLE	E-5092	7"	4515H

For Brake Repair Kit use E-9644 (5" Shoe) E-5086 (7" Shoe)

For Camshaft Repair Kit use E-2086B

MERITOR Q PLUS™ SERIES CAM BRAKES FOR 15" & 16 1/2" MX500 LONG LIFE & LX500 EXTENDED LUBE

CAST SPIDER

For Brake Repair Kit
use E-9046 (15") or
E-2769HD (16-1/2")

For Camshaft Repair Kit
use E-11904

Part	Page
E-654	1-252
E-1893	1-139
E-2766S	1-123
E-2767	1-150
E-2769HD	1-101
E-3007A	1-133
E-3490B	1-146
E-3859	1-253
E-5093	1-261
E-5095	1-253
E-9063	1-143
E-9064	1-81
E-10850	1-162
E-11453	1-158
E-11741	1-117
E-11904	1-216
E-11951	1-242

UNLINED SHOE	SIZE	FMSI
E-11453	15" x 5"	4703
E-10850	16-1/2" x 8"	4718

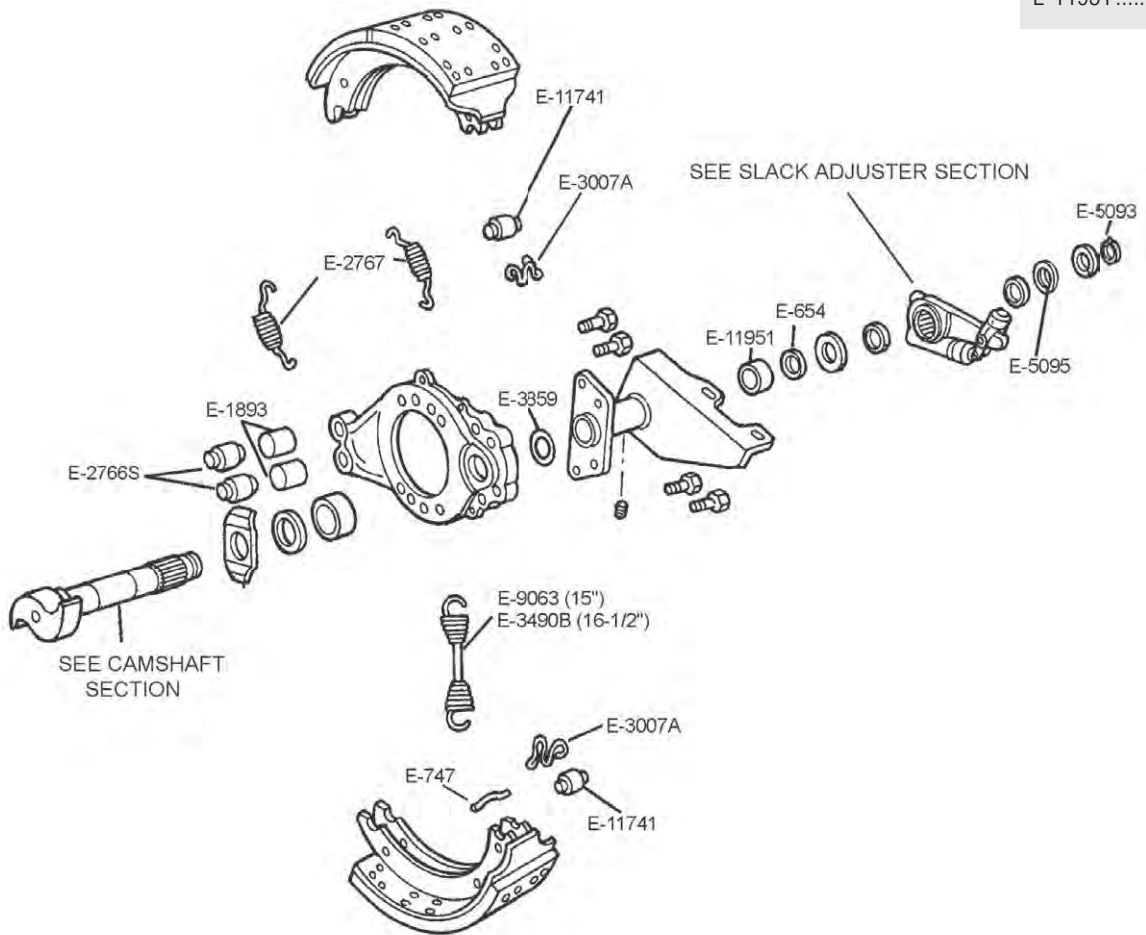

MERITOR Q PLUS™ SERIES CAM BRAKES FOR 15" & 16 1/2" MX500 LONG LIFE & LX500 EXTENDED LUBE

STAMPED SPIDER

Part	Page
E-654	1-252
E-747	1-151
E-2766S	1-123
E-2767	1-150
E-2769HD	1-101
E-3007A	1-133
E-3490B	1-146
E-5093	1-261
E-5095	1-253
E-10850	1-162
E-11741	1-84
E-11904	1-216
E-11951	1-242

**For Brake Repair Kit
use E-2769HD**

**For Camshaft Repair Kit
use E-11904**

UNLINED SHOE	FMSI
E-10850	4718

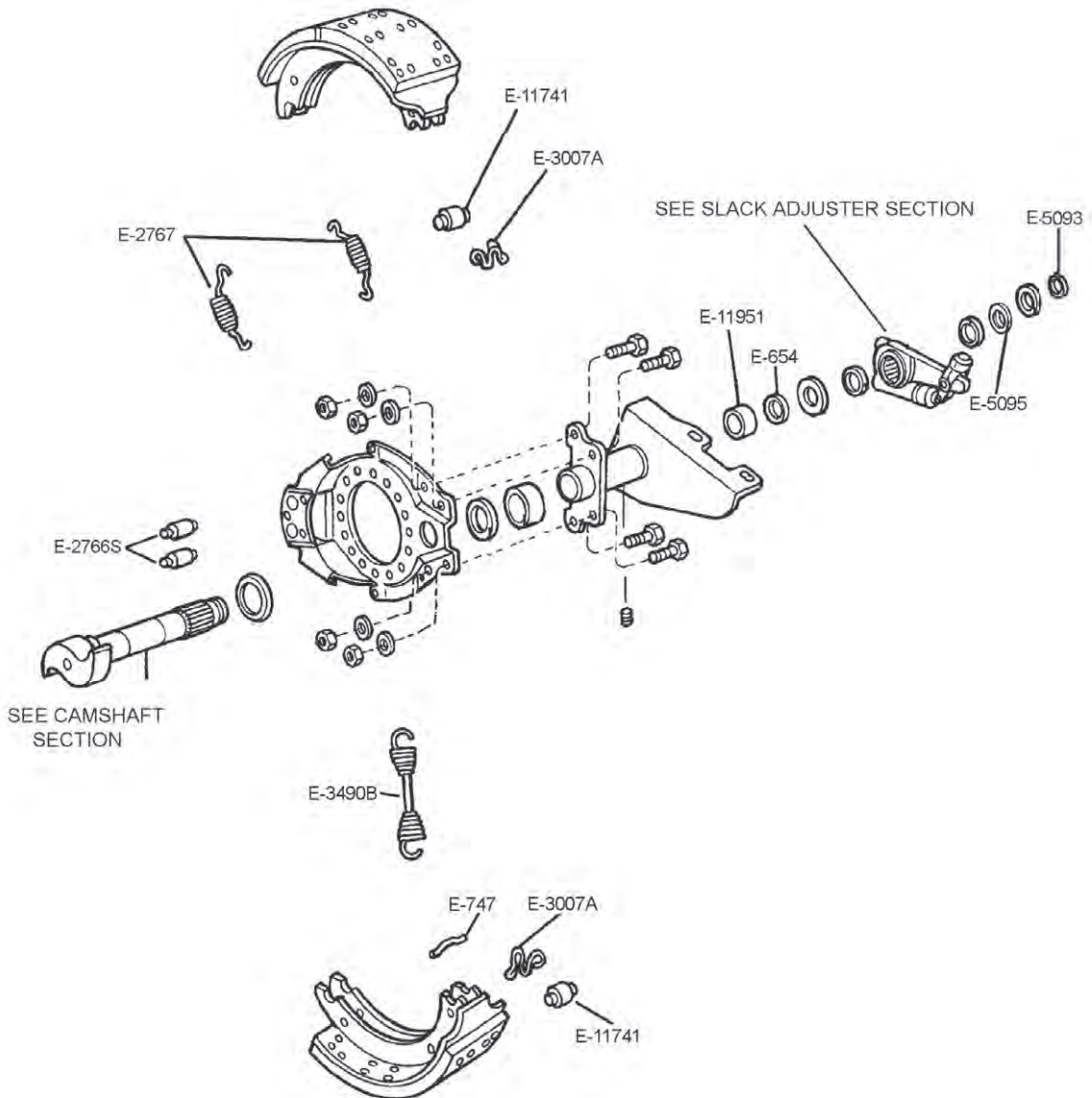

MERITOR 18" DIAMETER CAST BRAKES

TRUCK AND TRACTOR BRAKE

Part	Page
E-502	1-126
E-543	1-146
E-579A.....	1-135
E-654	1-252
E-801	1-131
E-1269.....	1-130
E-2218.....	1-138
E-3478.....	1-258
E-3479.....	1-257
E-3511.....	1-117
E-3512.....	1-147
E-3513.....	1-151
E-3518.....	1-115
E-3859.....	1-253
E-3992.....	1-114
E-3993B.....	1-214
E-4902.....	1-162
E-5093.....	1-261
E-5512.....	1-242

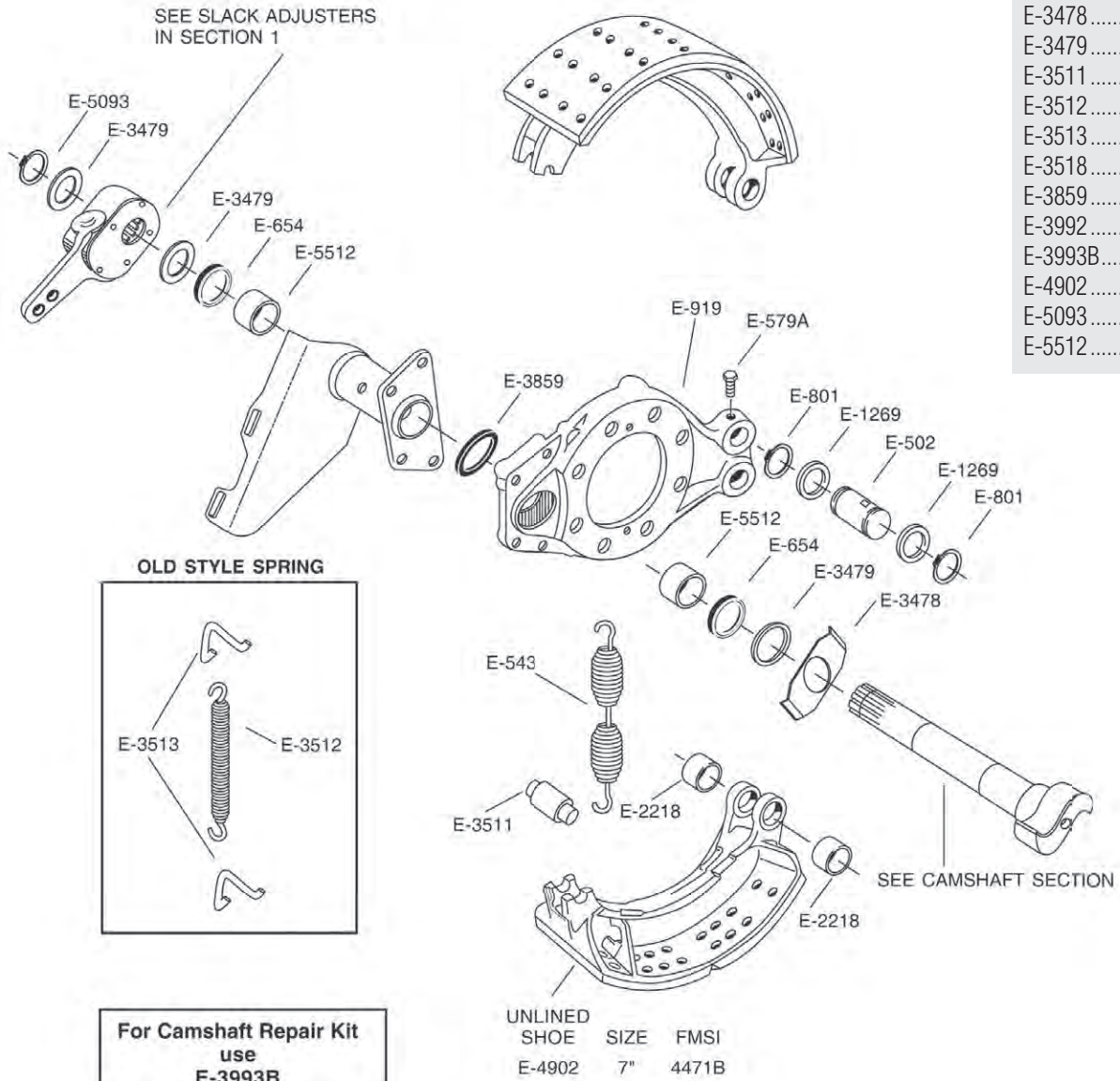

I.D. TIP

- Web support has two holes which hold the old style spring, which prevents shoe from resting in an offset position on anchor pin.

MERITOR EARLY MODEL TRAILER AXLES

HUB CAPS, SPINDLE NUTS, SEALS & STUDS

Part

- E-03009
 - E-04000
 - E-540
 - E-572
 - E-573
 - E-975
 - E-1251
 - E-1252
 - E-1253
 - E-2128
- See catalog
100WE for
component
details

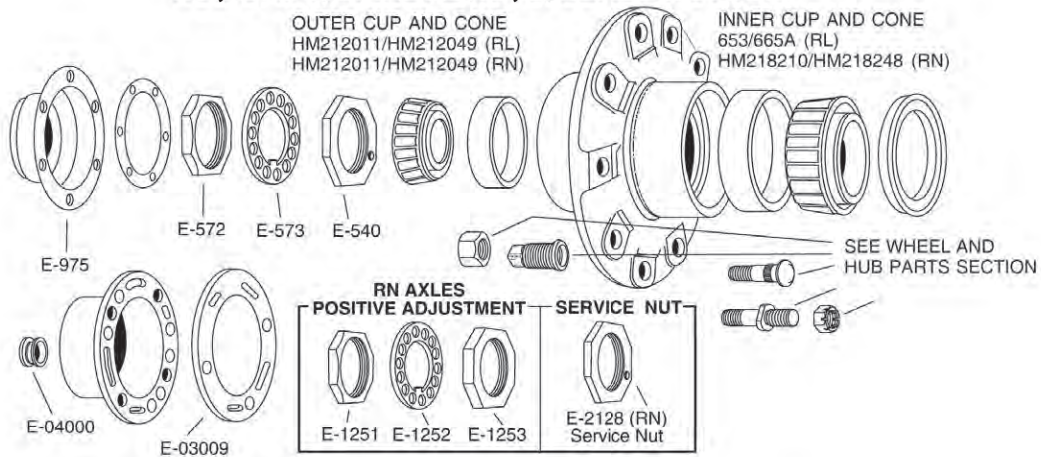

CAMSHAFT, BUSHINGS AND BRACKET PARTS

PartPage

- E-526 1-262
- E-536 1-243
- E-564 1-255
- E-580 1-256
- E-654 1-252
- E-759 1-244
- E-801 1-131
- E-1113 1-137
- E-1271 1-242
- E-1272 1-250
- E-1318A 1-237
- E-1318AHD.. 1-237
- E-1319A 1-235
- E-1416 1-250
- E-1569 1-262
- E-2088AHD.. 1-222
- E-2361 1-245
- E-2380 1-247
- E-2405 1-253
- E-2406 1-252
- E-2407 1-248
- E-2408 1-247
- E-2411A 1-256
- E-2690A 1-247
- E-3520A 1-228
- E-3520AHD.. 1-229
- E-3989AHD.. 1-229
- E-3991 1-252
- E-5093 1-261

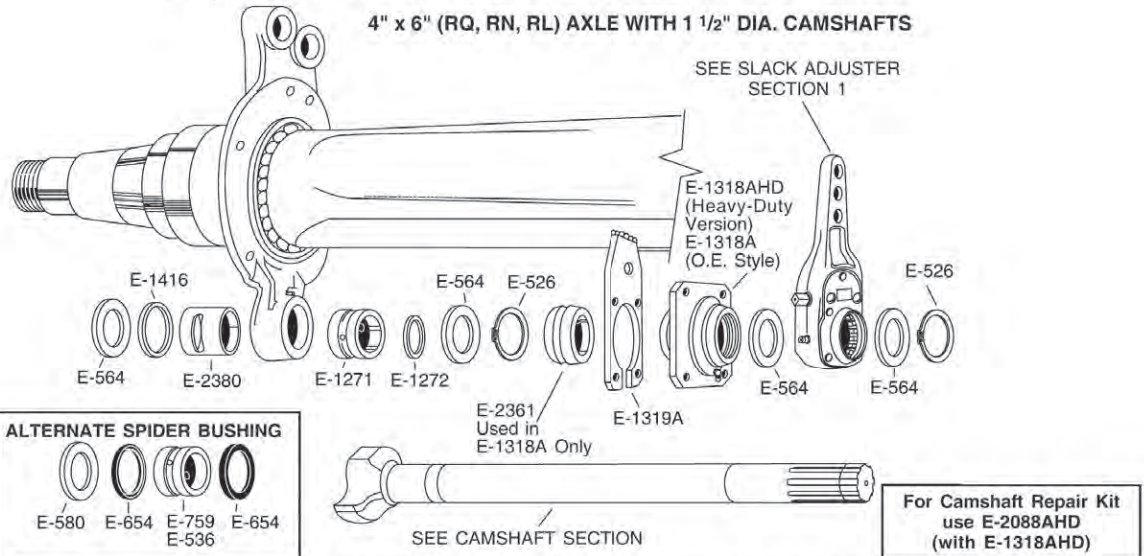

4000 - 6000 SERIES - 4" x 6" (RQ, RN, RL) AXLE WITH 1 5/8" DIA. CAMSHAFTS

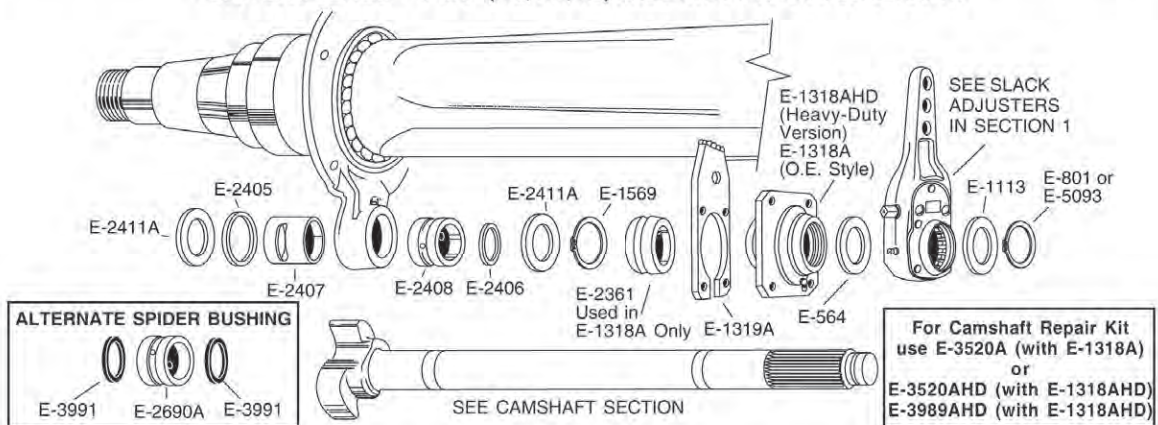

MERITOR EARLY MODEL TRAILER AXLES

CAMSHAFT, BUSHINGS AND BRACKET PARTS

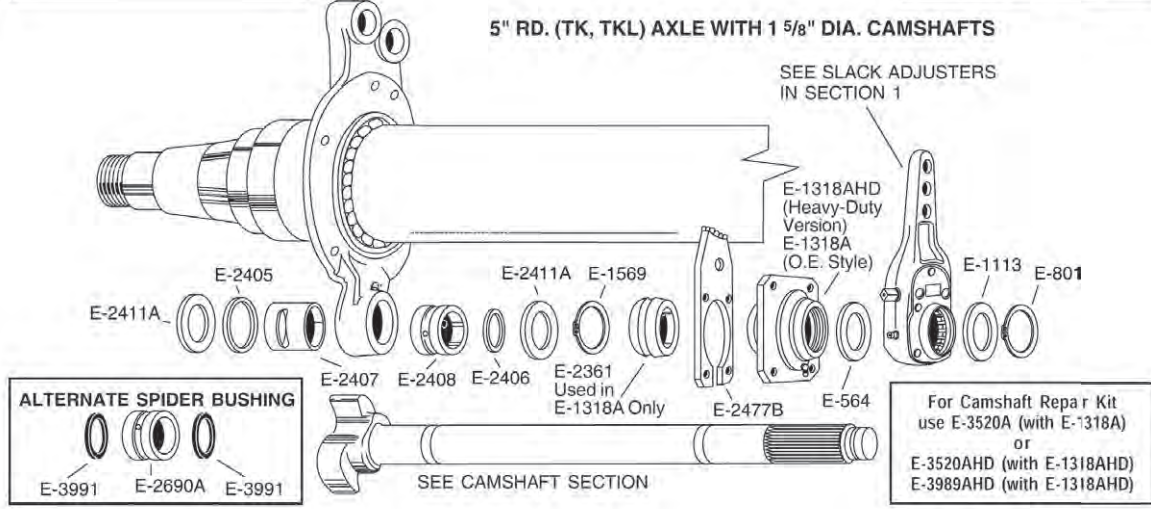
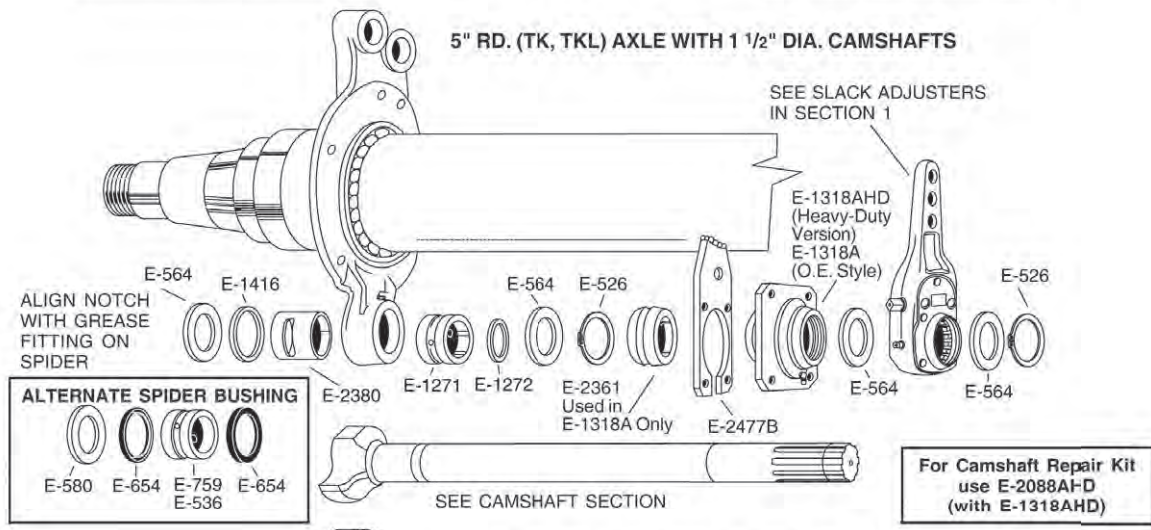
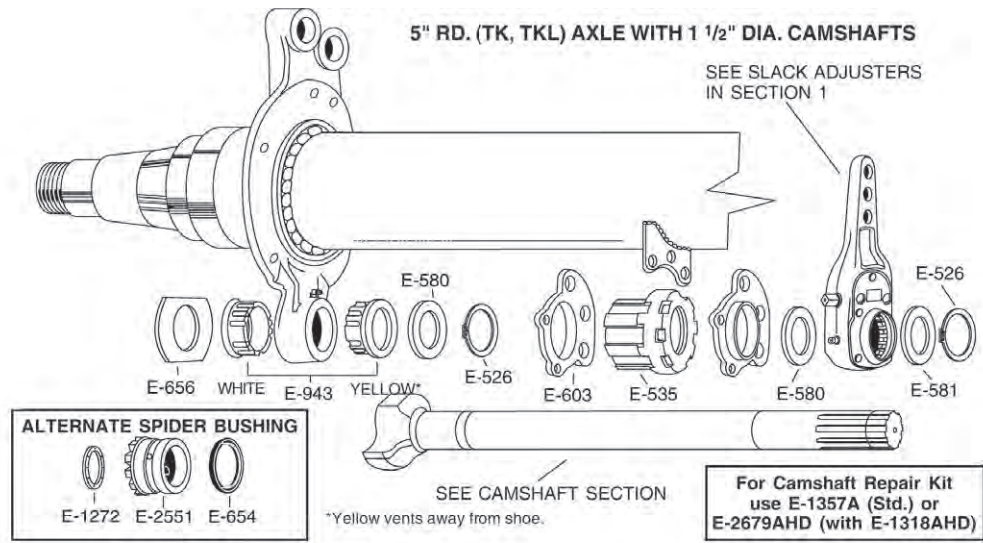

Part	Page
E-526	1-262
E-535	1-246
E-536	1-243
E-564	1-255
E-580	1-256
E-581	1-255
E-603	1-236
E-654	1-252
E-656	1-260
E-759	1-244
E-801	1-131
E-943	1-242
E-1113	1-137
E-1271	1-242
E-1272	1-250
E-1318A.....	1-237
E-1318AHD..	1-237
E-1357A.....	1-221
E-1416	1-250
E-1569	1-262
E-2088AHD..	1-222
E-2361	1-245
E-2380	1-247
E-2405	1-253
E-2406	1-252
E-2407	1-248
E-2408	1-247
E-2411A.....	1-256
E-2477B.....	1-235
E-2551	1-241
E-2679AHD..	1-227
E-2690A.....	1-247
E-3520A.....	1-228
E-3520AHD..	1-229
E-3989AHD..	1-229
E-3991	1-252

MERITOR TN, TP, TQ AND TR TRAILER AXLES

TN, TQ 2 5/8" SPINDLE - "MANUAL AND POSITIVE ADMUSTMENT SPINDLE NUTS

Part

E-540
E-572
E-975
E-1251
E-1253
E-1559
E-1561
E-2128
E-2303
E-2305
E-2550
E-3008
E-7658
E-7659
E-7660
E-7663
E-7664
E-7665
E-7666

See catalog
100WE for
component
details

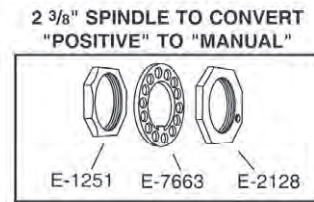
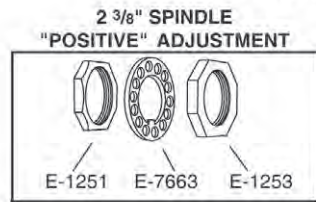
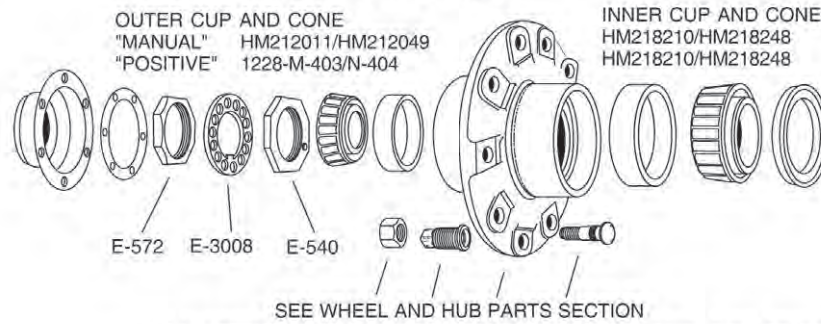

TP 3 1/2" SPINDLE - "MANUAL AND POSITIVE" ADMUSTMENT SPINDLE NUTS OLD DESIGN

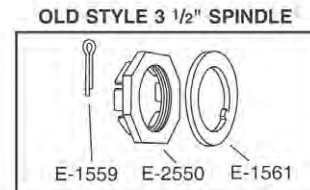
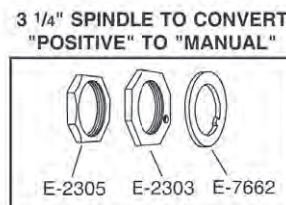
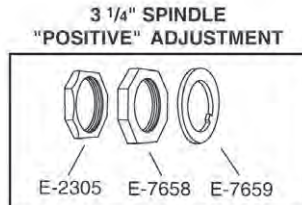
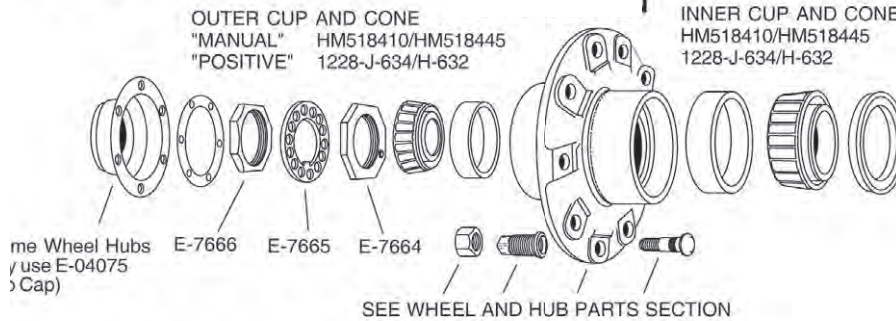

TP 3 1/4" SPINDLE - AVAILABLE AS "MANUAL" ADMUSTMENT ONLY NEW DESIGN

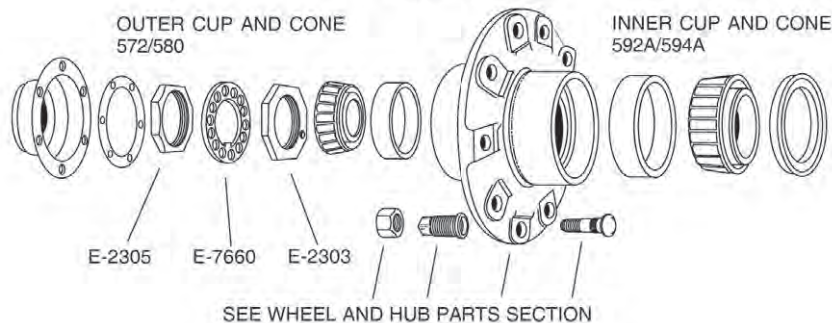

CURRENT DESIGN FABRICATED SPIDER WITH BOLT-ON METAL BUSHING

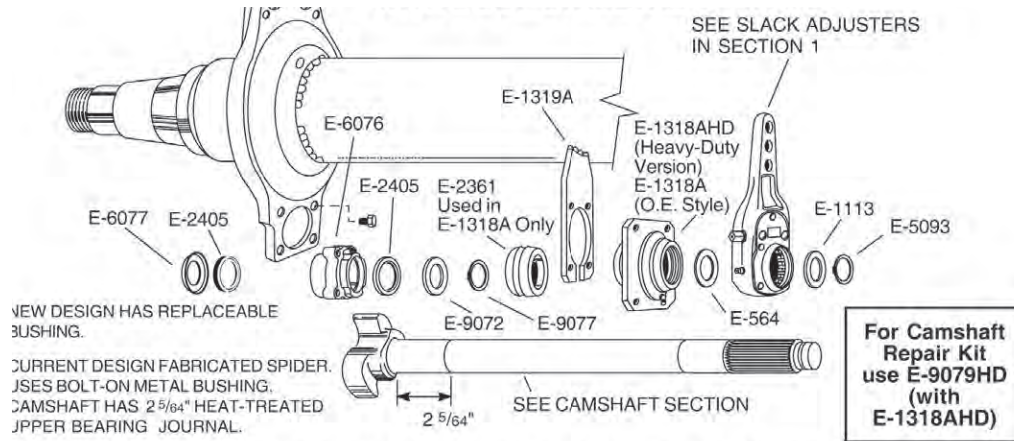

FIRST AND SECOND DESIGN FABRICATED SPIDER WITH PRESS-IN METAL BUSHING

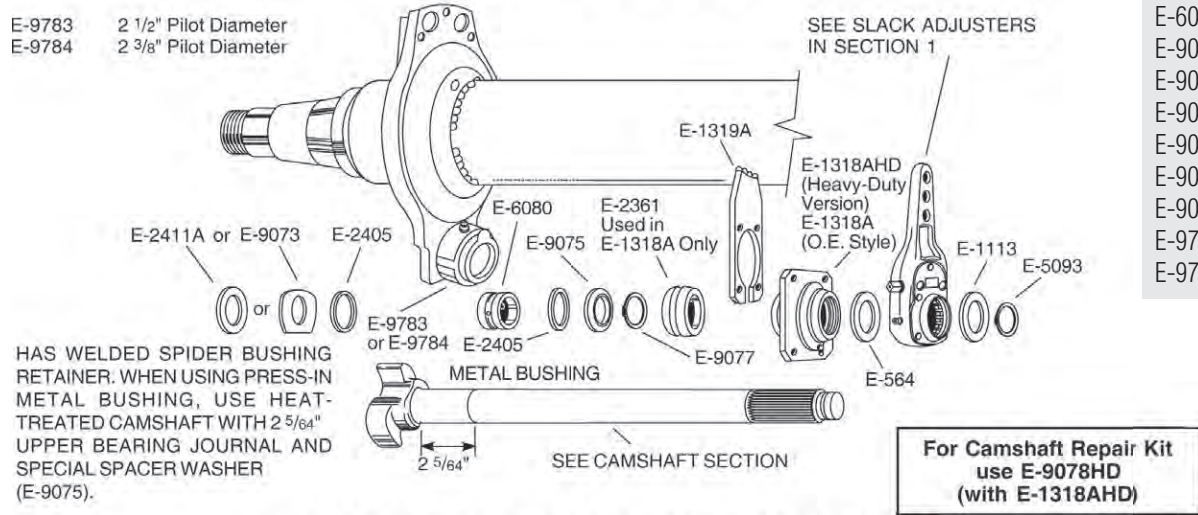

FIRST AND SECOND DESIGN FABRICATED SPIDER WITH PRESS-IN NYLON BUSHING

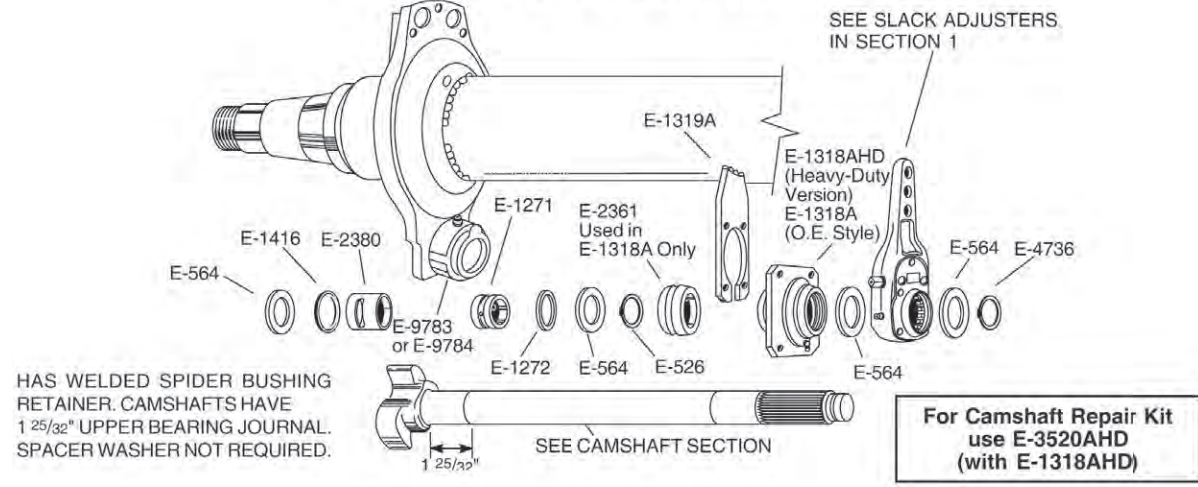

Part	Page
E-526	1-262
E-564	1-255
E-1113	1-137
E-1271	1-242
E-1272	1-250
E-1318A	1-237
E-1416	1-250
E-2088AHD ..	1-222
E-2361	1-245
E-2380	1-247
E-2405	1-253
E-2411A	1-256
E-4736	1-261
E-5063	1-175
E-6076	1-248
E-6077	1-259
E-6080	1-247
E-9072	1-257
E-9073	1-260
E-9075	1-259
E-9077	1-263
E-9078HD ...	1-232
E-9079HD ...	1-233
E-9783	1-248
E-9784	1-248

MERITOR TRAILER AXLES WITH 16 1/2" DIAMETER BRAKES

ANCHOR PIN VARIATIONS

Part	Page
E-502	1-126
E-801	1-131
E-1112A	1-125
E-1113	1-137
E-1816HD	1-113
E-1816S	1-111
E-1816SHD	1-112
E-1893	1-139
E-2119	1-126
E-2766S	1-123
E-2769HD	1-101
E-2769S	1-102
E-2769SHD	1-103
E-3895S	1-109
E-E895SHD	1-109
E-6999S	1-103
E-6999SHD	1-104
E-8938	1-139
KIT-4HD	1-106
KIT-4S	1-106
KIT-4SHD	1-107

"Q", "Q PLUS", "Q" FOR FRUEHAUF BRAKES

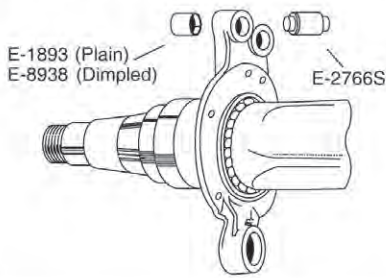

For Brake Repair Kit use E-2769HD, E-2769S, E-2769SHD, E-2769SHD-R, E-3895S, E-3895SHD, E-6999S, or E-6999SHD

"P" BRAKE

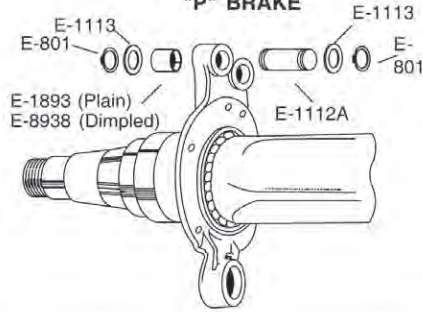

For Brake Repair Kit use E-1816S, E-1816HD or E-1816SHD

EARLY MODEL "P" BRAKE

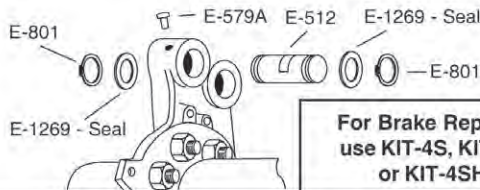

For Brake Repair Kit use KIT-4S, KIT-4HD or KIT-4SHD

Note: When using cast shoes or pressed steel shoes with bushings, use:

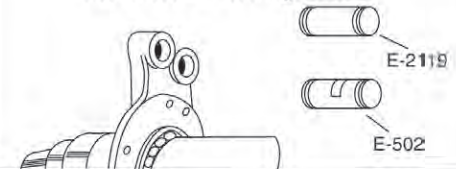

SHOES, ROLLERS, SPRING & DUST SHIELD

Part	Page
E-523	1-117
E-539	1-134
E-545A	1-144
E-747	1-151
E-886	1-165
E-1880B	1-145
E-2177	1-116
E-2241	1-161
E-2684	1-161
E-2767	1-150
E-2768	1-141
E-2778	1-162
E-3007A	1-133
E-3304	1-161
E-3417	1-161
E-3490B	1-146
E-3522	1-161
E-3775	1-166
E-5239	1-161
E-5503	1-162
E-6075	1-162

"P" BRAKE

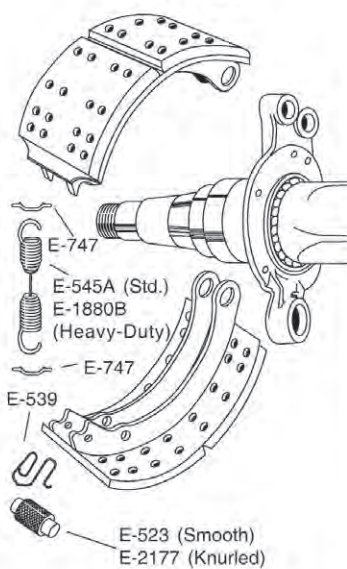

UNLINED SHOE	SIZE	FMSI
E-2684	6"	4514G
E-2241	7"	4515E
E-5239	8 5/8"	4551E

"Q" AND "Q PLUS" BRAKE

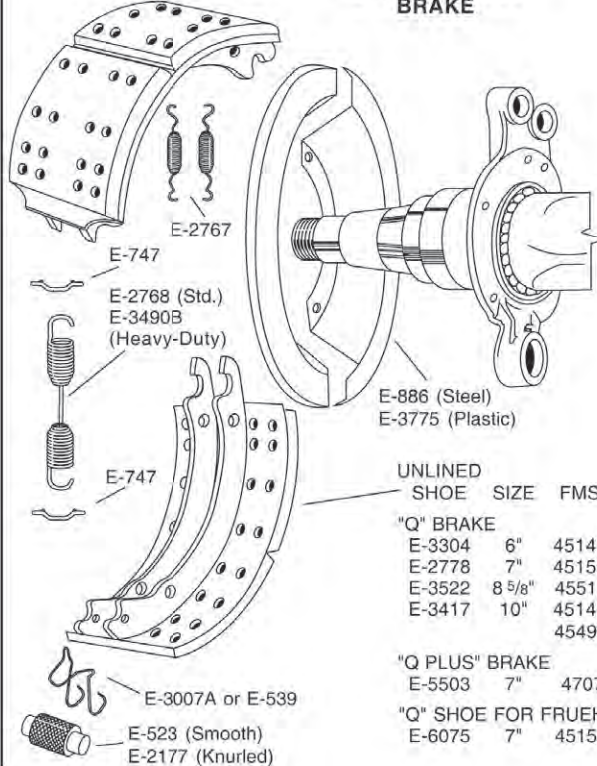

UNLINED SHOE	SIZE	FMSI	
"Q" BRAKE			
E-3304	6"	4514G	
E-2778	7"	4515G	
E-3522	8 5/8"	4551B	
E-3417	10"	4514G	} With 1/4" Rivets
E-3417	10"	4549C	
"Q PLUS" BRAKE			
E-5503	7"	4707	
"Q" SHOE FOR FRUEHAUF SPIDERS			
E-6075	7"	4515E	

SPICER (DANA) 12 1/4" DIAMETER "FAST CHANGE II" BRAKES

OLD SPIDER BEFORE 11/11/96 WITH NEW SHOE ANCHOR PIN O.D. 1"

UNLINED SHOE	SIZE	FMSI
E-10762	5 1/2"	4536E
E-10763	7 1/2"	4692

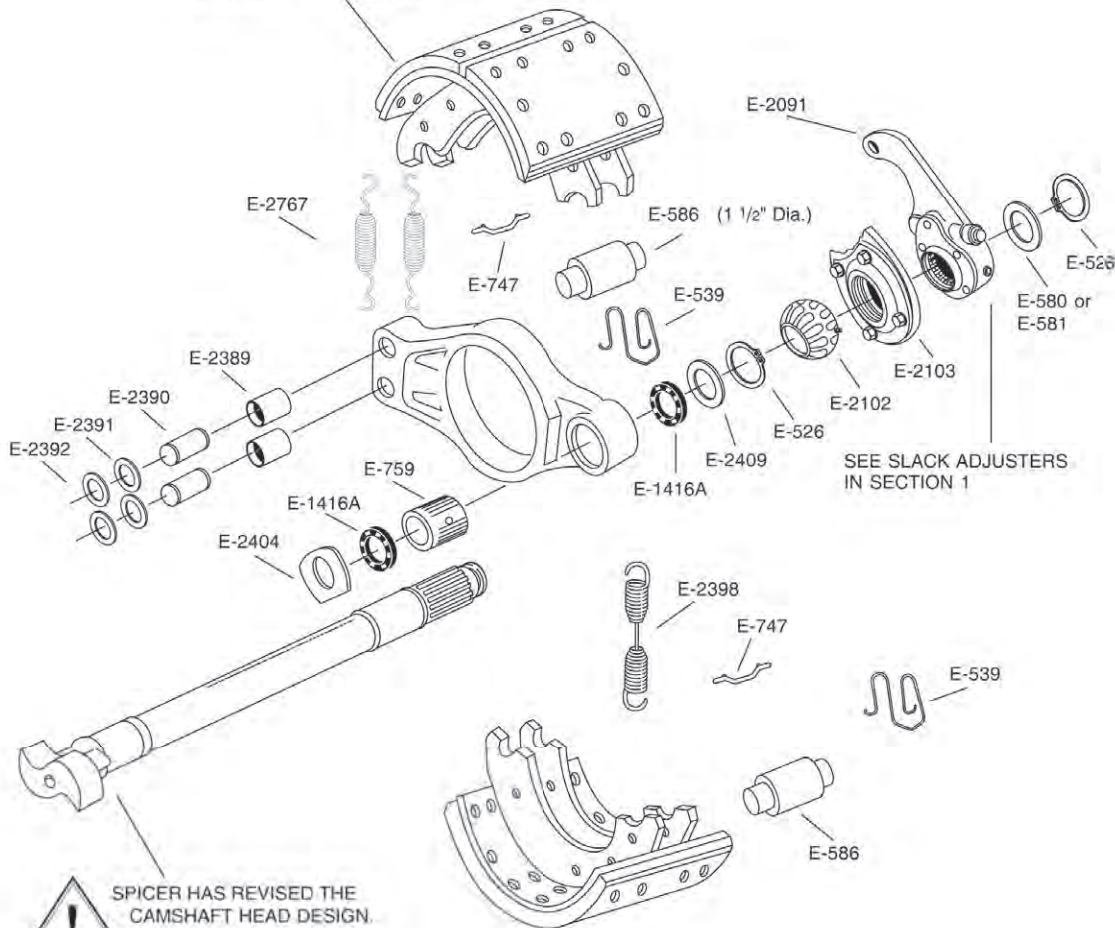

Part	Page
E-526	1-262
E-527	1-130
E-539	1-134
E-580	1-256
E-747	1-151
E-807	1-244
E-1416A	1-251
E-2091	1-265
E-2102	1-245
E-2103	1-235
E-2177	1-116
E-2395	1-119
E-2396	1-122
E-2398	1-142
E-2399	1-151
E-2404	1-259
E-2409	1-256
E-2767	1-150
E-3782	1-77
E-5303A	1-158
E-5304	1-123
E-5305	1-150
E-5306	1-77
E-5307	1-212
E-9283	1-77
E-10762	1-156
E-10763	1-156

CAUTION
SPICER HAS REVISED THE CAMSHAFT HEAD DESIGN.

**For Brake Shoe Repair Kit
use
E-10757**

**For Camshaft Repair Kit
use
E-2469**

I.D. TIP
Brake Shoe Unique.

SPICER (DANA) 12 1/4" DIAMETER

NEW SPIDER AFTER 11/1/96 ANCHOR PIN O.D. 1 1/4"

Part	Page
E-526	1-262
E-527	1-130
E-539	1-134
E-580	1-256
E-747	1-151
E-807	1-244
E-1416A	1-251
E-2091	1-265
E-2102	1-245
E-2103	1-235
E-2177	1-116
E-2395	1-119
E-2396	1-122
E-2398	1-142
E-2399	1-151
E-2404	1-259
E-2409	1-256
E-2767	1-150
E-3782	1-77
E-5303A	1-158
E-5304	1-123
E-5305	1-150
E-5306	1-77
E-5307	1-212
E-9283	1-77
E-9790A	1-213
E-10762	1-156
E-10763	1-156

UNLINED SHOE	SIZE	FMSI
E-10762	5 1/2"	4536E
E-10763	7 1/2"	4692

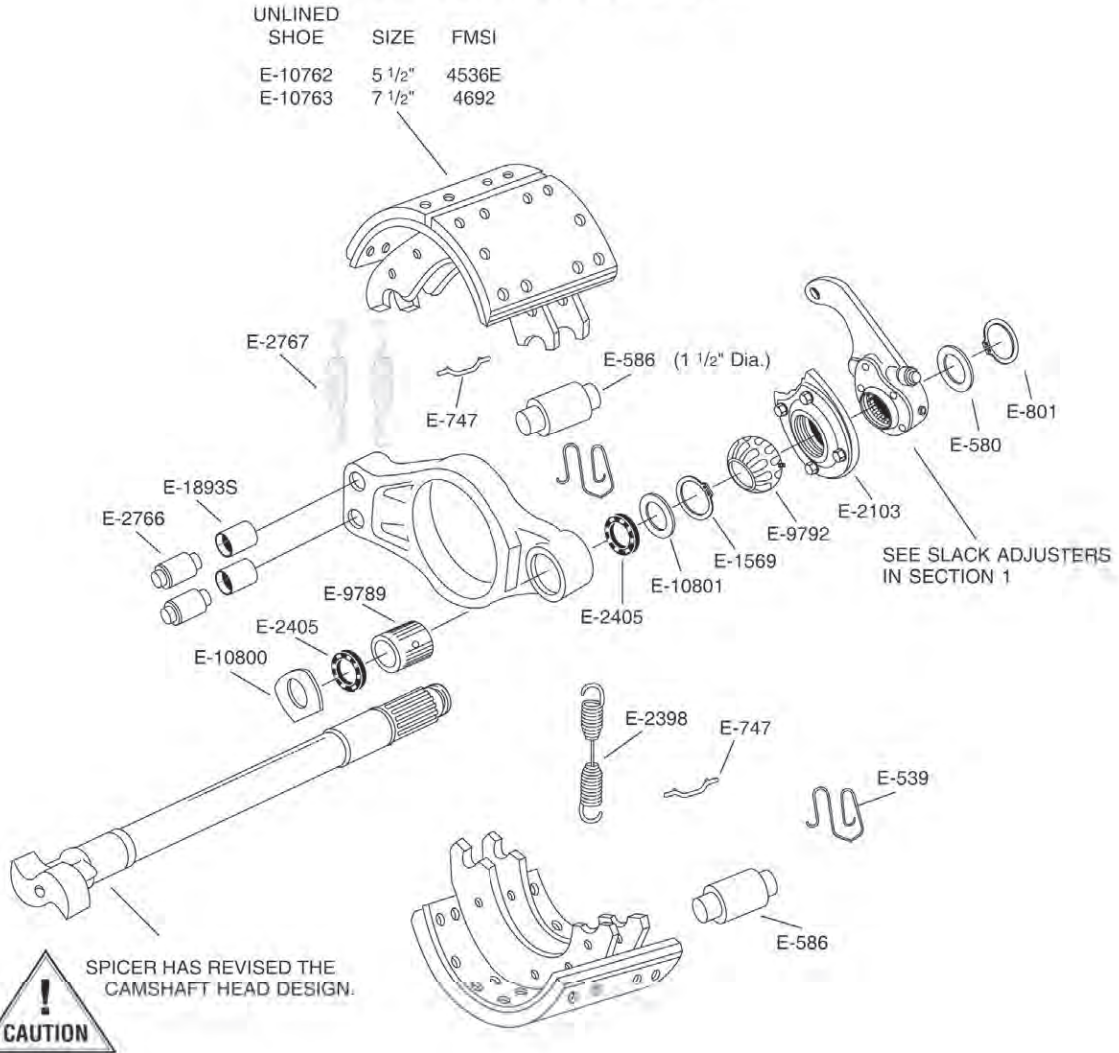

**NOTE: With New Spider
1 5/8" Dia. Camshaft Journal
and 1 1/2" 28 Spline use
E-9790A Camshaft Repair Kit**

**For Brake Repair Kit
use
E-10756**

S.O.S.

Special Order Service

Can't find it? Trouble sourcing parts? Need assistance?

Let Euclid's Special Order Service (S.O.S.) help.

Euclid's position as the market leader provides you access to the products and manufacturers listed below. These entire product lines are available to you by just placing a phone call to Euclid's S.O.S. Department at 866-238-2543 (option 3) in the U.S. or 800-387-3889 in Canada.

AIR BRAKE PARTS

Anchorlok Brake Chambers
 Euclid Brake Chambers
 Bendix (Allied Signal)
 Brake Shoes
 Camshafts
 Dana
 Fruehauf
 Haldex

HYDRAULIC BRAKE PARTS

Calipers - New, Remanufactured & Loaded
 Clutch Master Cylinders
 Clutch Slave Cylinders
 Disc Pads
 Bendix
 Dayton
 EIS
 Lucas
 Master Cylinders
 Rotors
 Wagner Brake
 Wheel Cylinders

FRICTION MATERIAL

Hydraulic Disc Pads
 Euclid Stopmate
 Performance Friction
 Air Brakes Drum
 Euclid Friction Material

FRONT END PARTS

King Pin Kits
 Tie Rod Ends
 Drag Link Ends
 Drag Links

SUSPENSION PARTS

Binkley
 Cambria
 Chalmers
 Fruehauf
 Hendrickson
 Hendrickson Axle Division
 Hendrickson Turner
 Hutchens
 Kwik-Loc (Jifflox)
 Meritor
 Neway
 Reyco/Transpro
 Ridewell
 Torque Arms
 Trailmobile
 Full suspensions are available

WHEEL AND HUB PARTS

ConMet
 Dayton
 Gunite

SHOCK ABSORBERS & AIR SPRINGS

Gabriel Shock Absorbers
 Firestone Air Springs

CARGO RESTRAINT

Ancra

TOOLS AND SHOP EQUIPMENT

Fraser Gauge Company
 Kent Moore
 Ken Tool
 OTC (Owatonna Tool Company)
 Tiger Tool

PARTS FOR SPICER (DANA)...

Part

E-03009
 E-04000 See catalog
 E-540 100WE for
 E-572 component
 E-573 details
 E-975

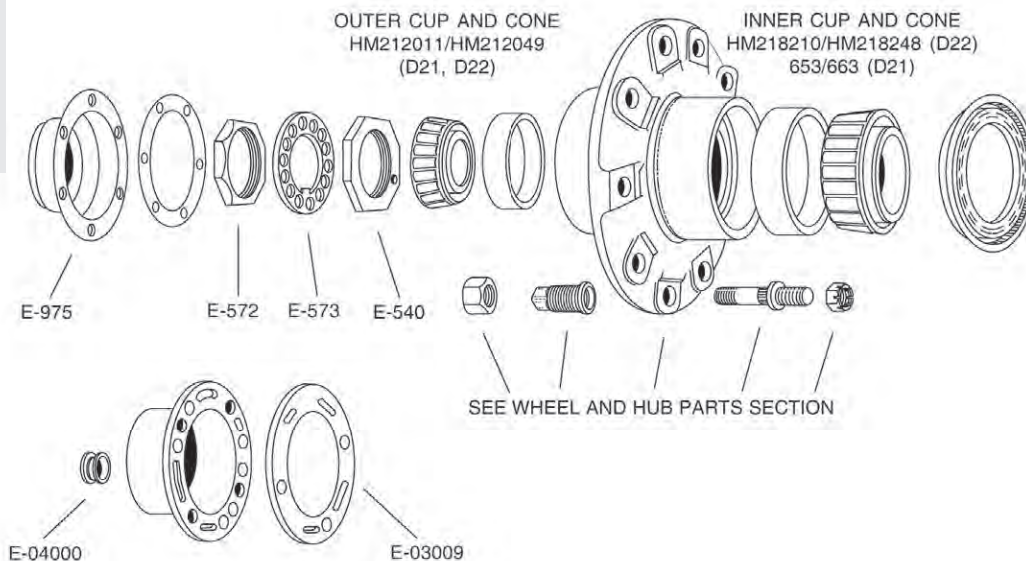

CAMSHAFT, BUSHINGS AND BRACKET PARTS

Part Page

E-526 1-262
 E-536 1-243
 E-580 1-256
 E-719 1-257
 E-759 1-244
 E-807 1-244
 E-957 1-163
 E-1416A 1-251
 E-2087 1-222
 E-2102 1-245
 E-2104 1-235
 E-2287 1-225

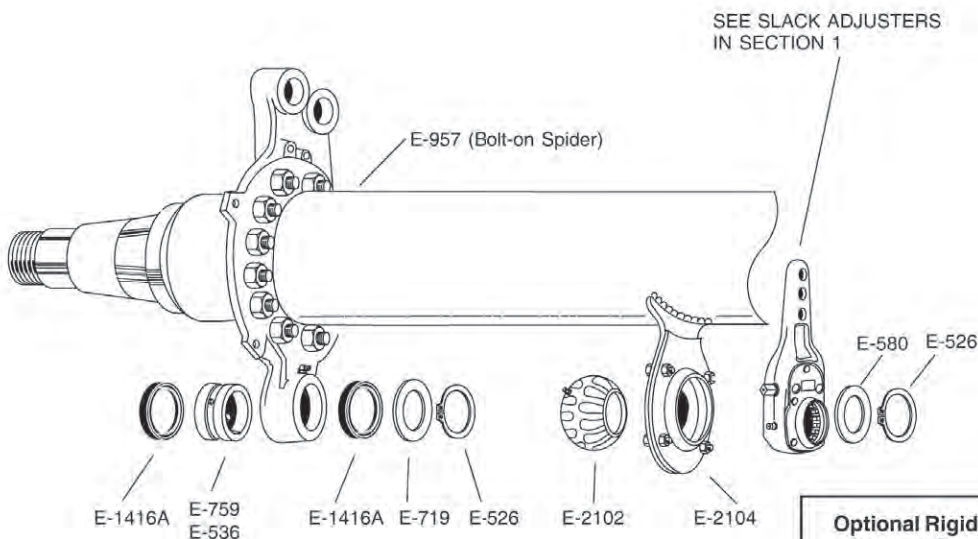

For Camshaft Repair Kit
 use
 E-2287

SEE CAMSHAFT SECTION

Optional Rigid Cam Support Bracket

E-759 (Nylon)
 E-807 (Bronze)

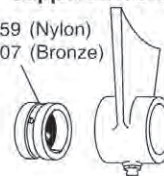

For Camshaft Repair
 Kit use E-2087

ANCHOR PIN VARIATIONS

"FAST CHANGE" AND "XTRALIFE" "XL" BRAKES

E-1893 (Plain)
E-8938 (Dimpled)

E-2766S

ALTERNATE BRAKE PARTS

E-1893 (Plain)
E-8938 (Dimpled)

E-801

E-801 E-1113

E-1112A E-1113

"FAST CHANGE"

For Brake Repair Kit use E-2769HD, E-2769S, E-2769SHD, E-3895S, E-3895SHD, E-6999S, or E-6999SHD

"XTRALIFE"

For Brake Repair Kit use E-5515

"ALTERNATE"

For Brake Repair Kit use E-1816HD, E-1816S, E-1816SHD

Part	Page
E-801	1-131
E-1112A.....	1-125
E-1113	1-137
E-1816HD	1-113
E-1816S.....	1-111
E-1816SHD..	1-112
E-1893	1-139
E-2766S.....	1-123
E-2769HD	1-101
E-2769S.....	1-102
E-2769SHD..	1-103
E-3895S.....	1-109
E-3895SHD..	1-109
E-5515	1-108
E-6999S.....	1-103
E-6999SHD..	1-104
E-8938	1-139

SHOES, ROLLERS, SPRING & DUST SHIELD

ALTERNATE BRAKE PARTS

E-886 (Steel)
E-3775 (Plastic)

E-747

E-545A (Std.)
E-1880B (Heavy-Duty)

E-523 (Smooth)
E-2177 (Knurled)

E-539

UNLINED SHOE	SIZE	FMSI
E-2241	7"	4515E

"FAST CHANGE" AND "XTRALIFE" "XL" BRAKES

E-747

E-2768 (Std.)
E-3490B (Heavy-Duty)

"Fast Change"
E-523 (Knurled)
E-2177 (Knurled)

"XL"
E-1582

E-3007A or E-539

UNLINED SHOE	SIZE	FMSI
E-2778	7"	4515E "Fast Change"
E-2778	7"	4701 "XL"

Part	Page
E-523	1-117
E-539	1-134
E-545A.....	1-144
E-747	1-151
E-886	1-165
E-1582	1-117
E-1880B.....	1-145
E-2177	1-116
E-2241	1-161
E-2767	1-150
E-2768	1-141
E-2778	1-162
E-3007A.....	1-133
E-3304	1-161
E-3417	1-161
E-3490B.....	1-146
E-3775	1-166

STD. FORGE AXLE WITH 12 1/4 DIAMETER BRAKES

HUB CAPS, SPINDLE NUTS, SEALS & STUDS

Part

E-03009
 E-04000
 E-540 See catalog
 E-572 100WE for
 E-573 component
 E-617 details
 E-618
 E-619
 E-975
 E-2237

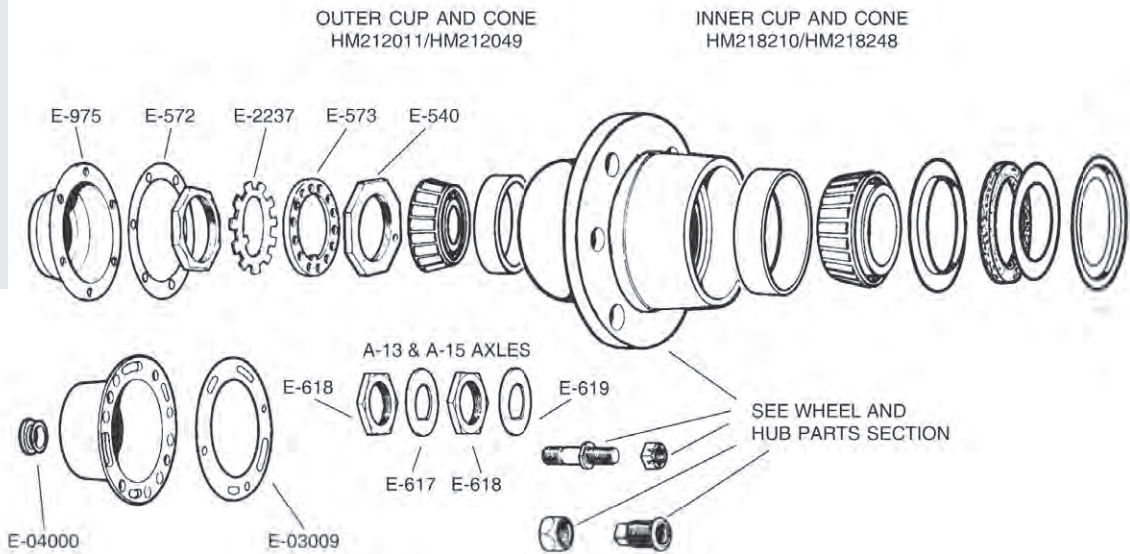

Part Page

E-526 1-262
 E-580 1-256
 E-759 1-244
 E-807 1-244
 E-1416A 1-251
 E-2091 1-265
 E-2102 1-245
 E-2103 1-235
 E-2104 1-235
 E-2409 1-256
 E-2469 1-211
 E-2526 1-212

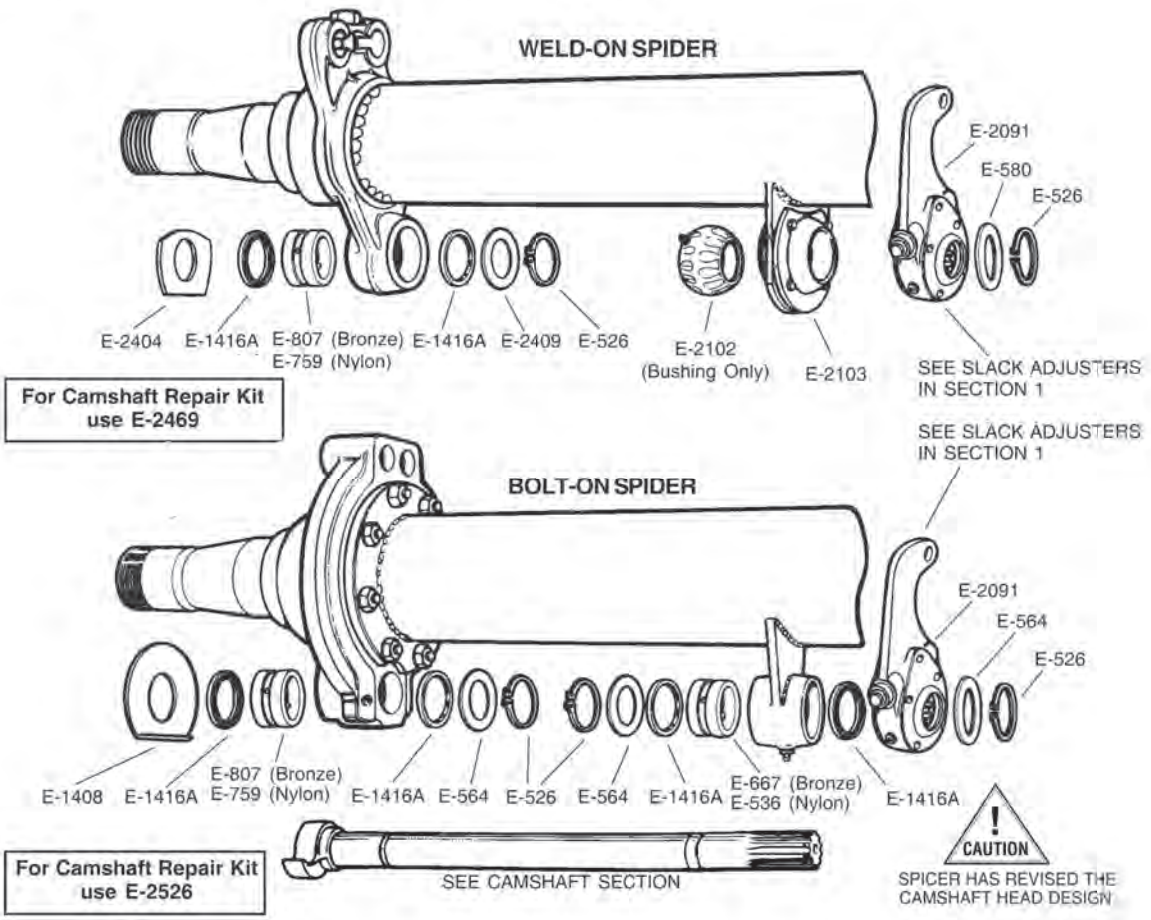

STD. FORGE AXLE WITH 12 1/4 DIAMETER BRAKES

ANCHOR PIN VARIATIONS

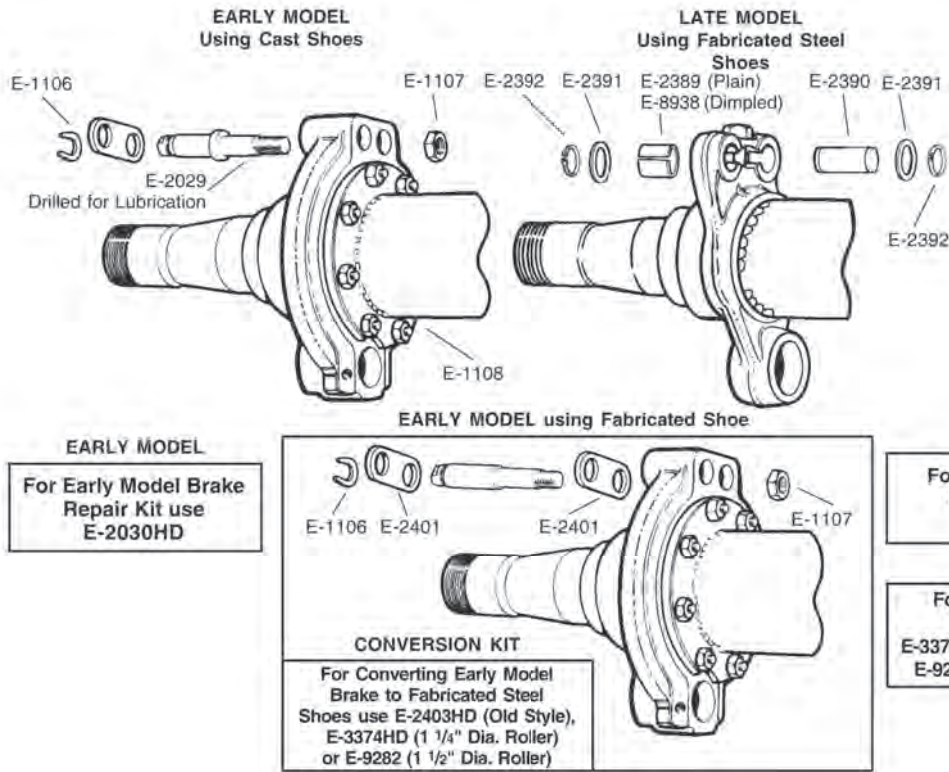

Part	Page
E-1106	1-128
E-1107	1-132
E-1108	1-163
E-2029	1-127
E-2030HD	1-78
E-2389	1-139
E-2390	1-125
E-2391	1-137
E-2392	1-130
E-2401	1-132
E-2402HD	1-78
E-2403HD	1-73
E-3373HD	1-76
E-3374HD	1-73
E-8938	1-139
E-9281	1-76
E-9282	1-73

SHOES, ROLLERS, SPRING & DUST SHIELD

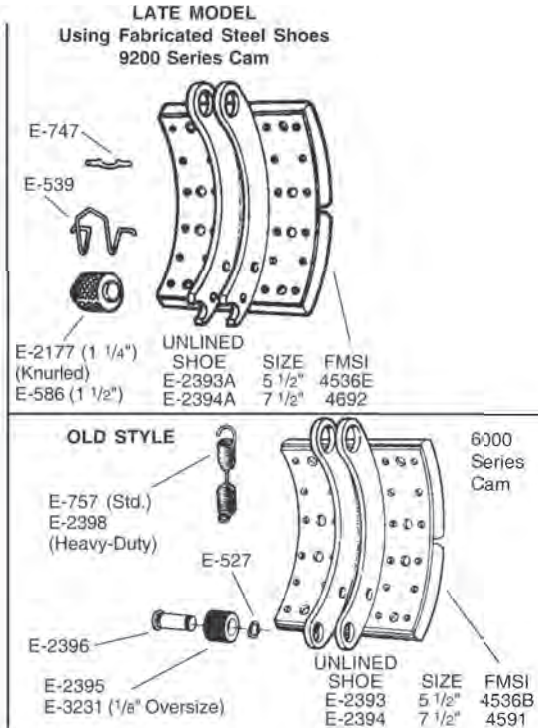
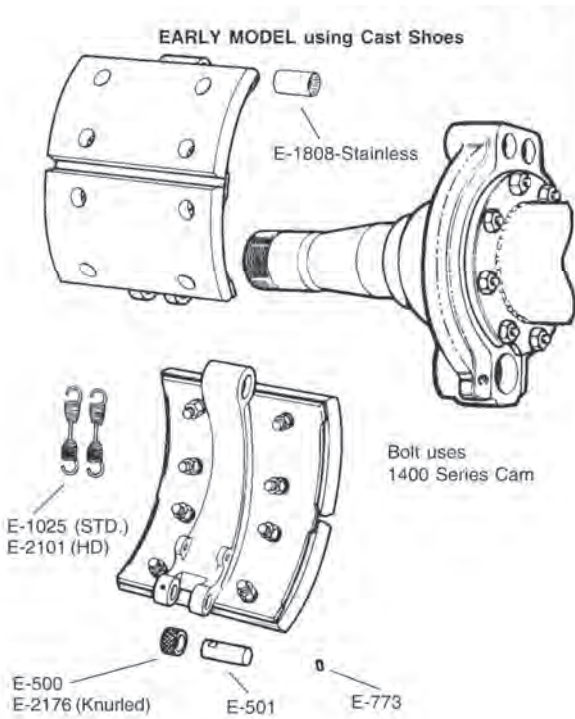

Part	Page
E-500	1-120
E-501	1-122
E-527	1-130
E-539	1-134
E-747	1-151
E-757	1-141
E-773	1-135
E-1025	1-141
E-1808	1-137
E-2101	1-142
E-2176	1-119
E-2177	1-116
E-2393	1-157
E-2393A	1-156
E-2394	1-157
E-2394A	1-156
E-2395	1-119
E-2396	1-122
E-2398	1-142
E-3231	1-119

PARTS FOR STD. FORGE A-17, A-19 & A-22...

HUB CAPS, SPINDLE NUTS, SEALS & STUDS

Part

E-03009
 E-04000 See catalog
 E-540 100WE for
 E-572 component
 E-573 details
 E-975
 E-2237

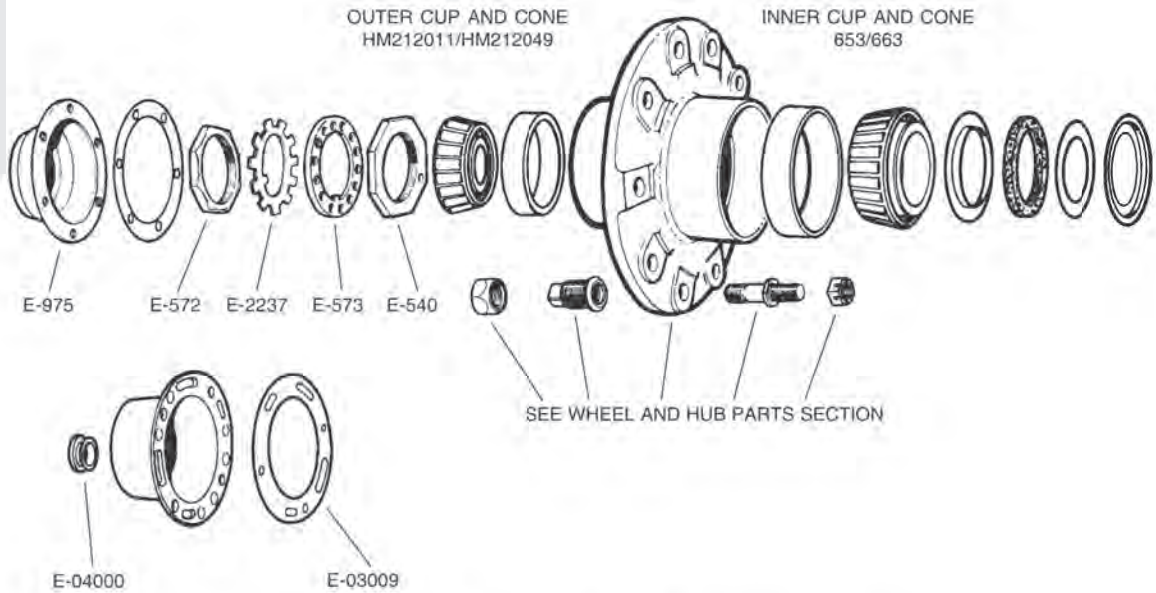

CAMSHAFTS, BUSHINGS AND BRACKET PARTS

PartPage

E-526 1-262
 E-536 1-243
 E-580 1-256
 E-719 1-257
 E-759 1-244
 E-807 1-244
 E-957 1-163
 E-1416A 1-251
 E-2087 1-222
 E-2102 1-245
 E-2104 1-235
 E-2287 1-225
 E-2409 1-256

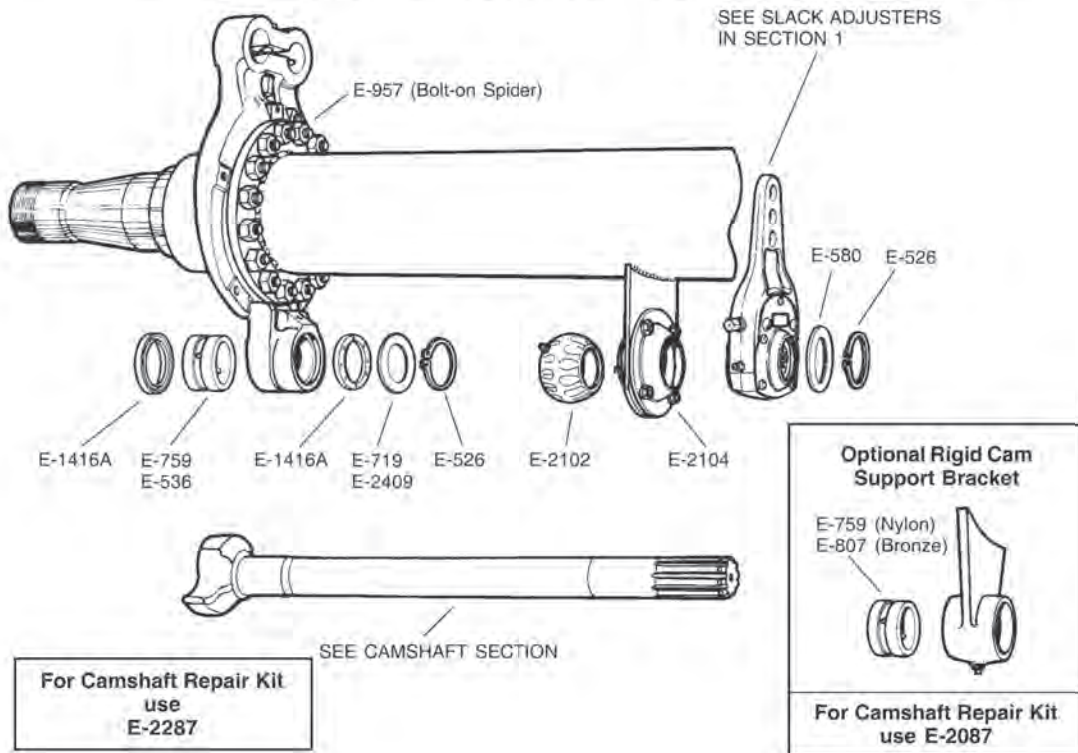

ANCHOR PIN VARIATIONS

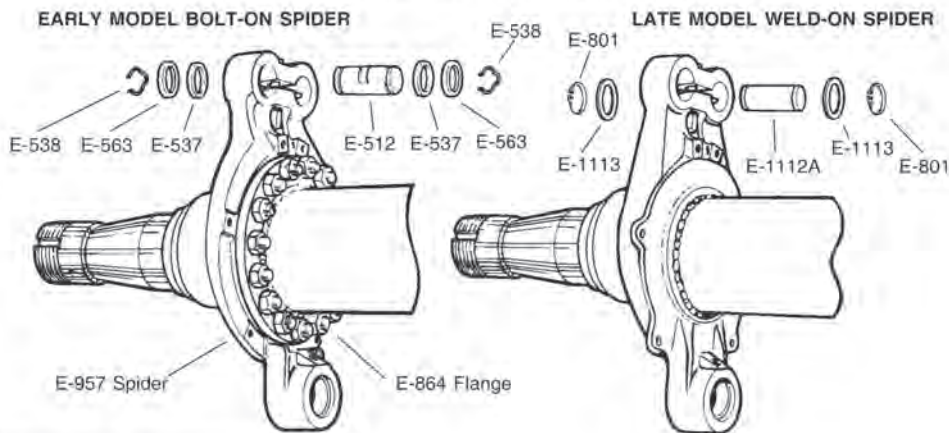

**For Brake Repair Kit use
KIT-4HD, KIT-4S, KIT-4SHD**



Part	Page
E-502	1-126
E-512	1-125
E-537	1-129
E-538	1-131
E-563	1-129
E-801	1-131
E-864	1-163
E-957	1-163
E-1112A	1-125
E-1113	1-137
E-2119	1-126
KIT-4HD	1-106
KIT-4S	1-106
KIT-4SHD	1-107

SHOES, ROLLERS, SPRING & DUST SHIELD

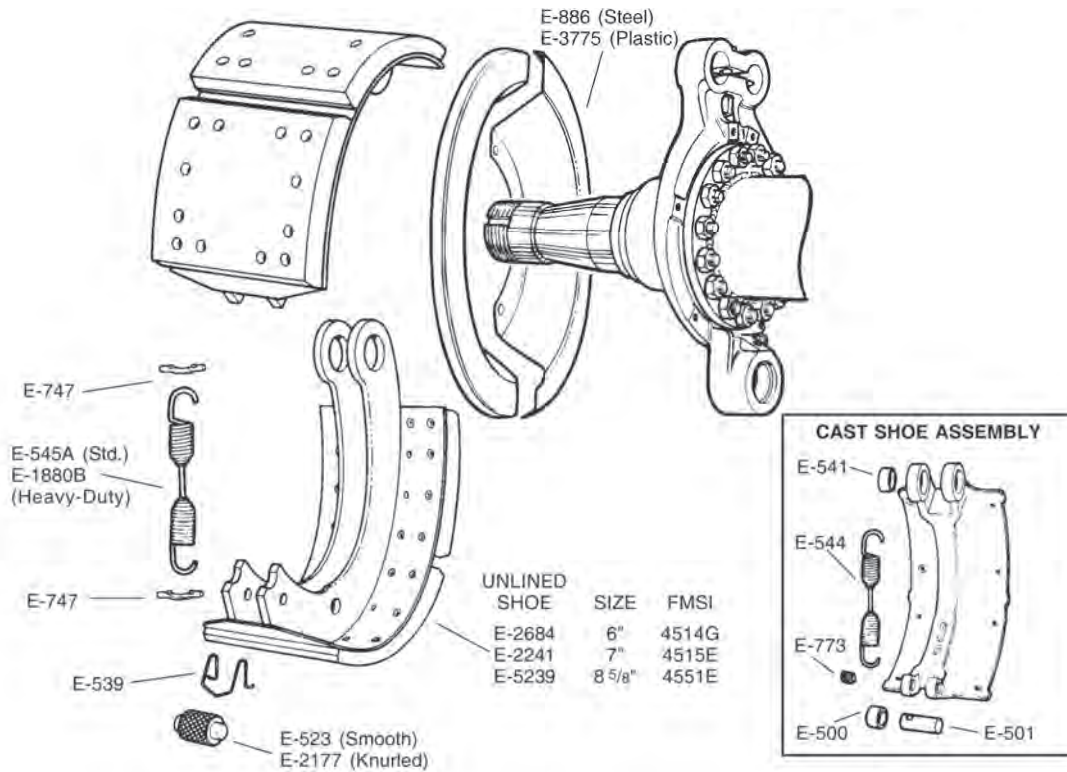

Part	Page
E-500	1-120
E-501	1-122
E-523	1-117
E-539	1-134
E-541	1-138
E-544	1-144
E-747	1-151
E-773	1-135
E-886	1-165
E-1880B	1-145
E-2177	1-116
E-2241	1-161
E-2684	1-161
E-3775	1-166
E-5239	1-161

WAGNER 15" DIAMETER BRAKES

FRONT AXLE

Part Page

E-979 1-143
 E-2723 1-131
 E-2724 1-136
 E-2725 1-135
 E-2726 1-136
 E-2728 1-159
 E-2729 1-259
 E-2732 1-241
 E-2733 1-253
 E-2734 1-260
 E-2740 1-84
 E-2770 1-143
 E-2798 1-129
 E-3291 1-85
 E-3353A 1-217
 E-3421A 1-118
 E-4785 1-159
 E-4961A 1-132

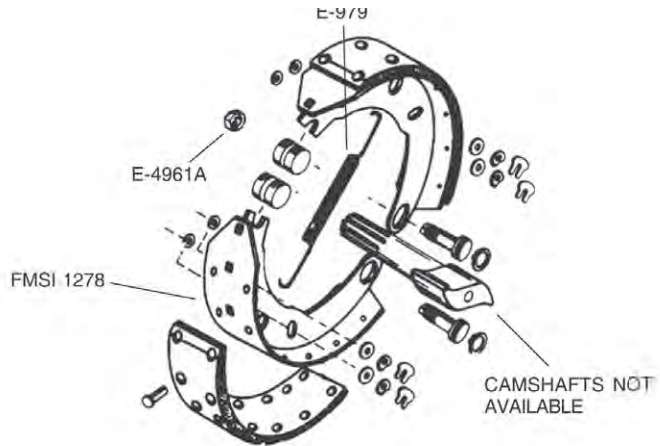
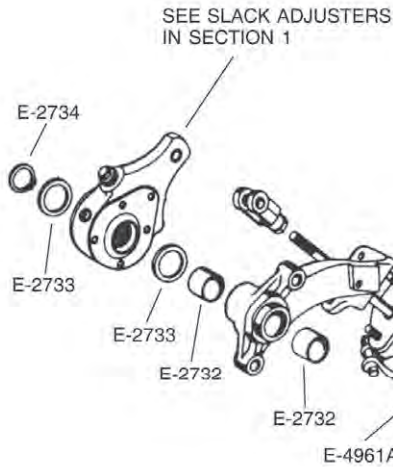

15" x 3 1/2"

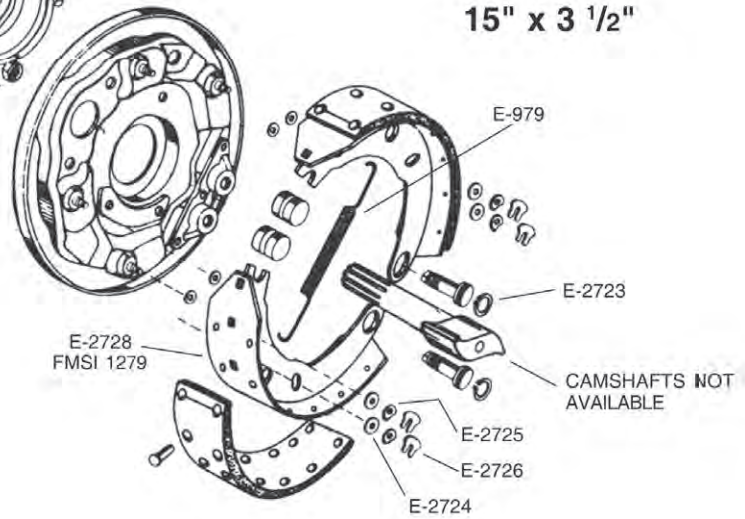

BRAKE REPAIR KITS

For 15" x 3 1/2"
use E-2740

For 15" x 4"
use E-3291

For Camshaft Repair Kit
use
E-3353A

UNLINED SHOE	SIZE	FMSI
N/A	3"	1278
E-2728	3 1/2"	1279
E-2729	4"	1308A
	(Thin Web)	
E-4785	4"	1308A
	(Thin Web)	

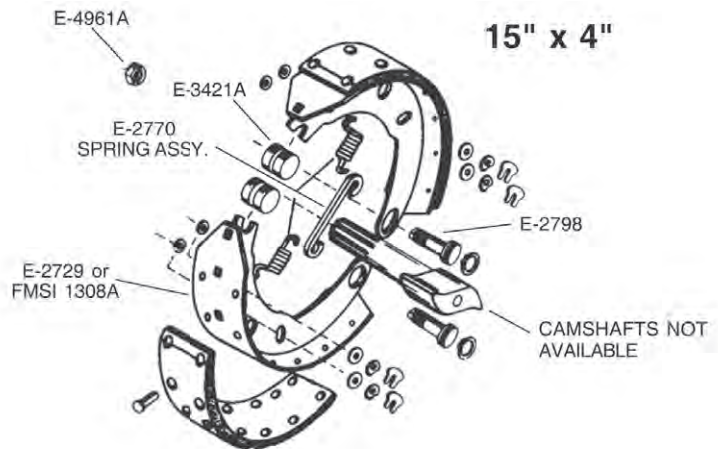

WAGNER 15" DIAMETER BRAKES

Part	Page
E-801	1-131
E-980	1-143
E-1269	1-130
E-1337	1-124
E-2409	1-256
E-2712	1-159
E-2713	1-86
E-2714A	1-176
E-2715A	1-176
E-2717	1-251
E-3354	1-217
E-4736	1-261

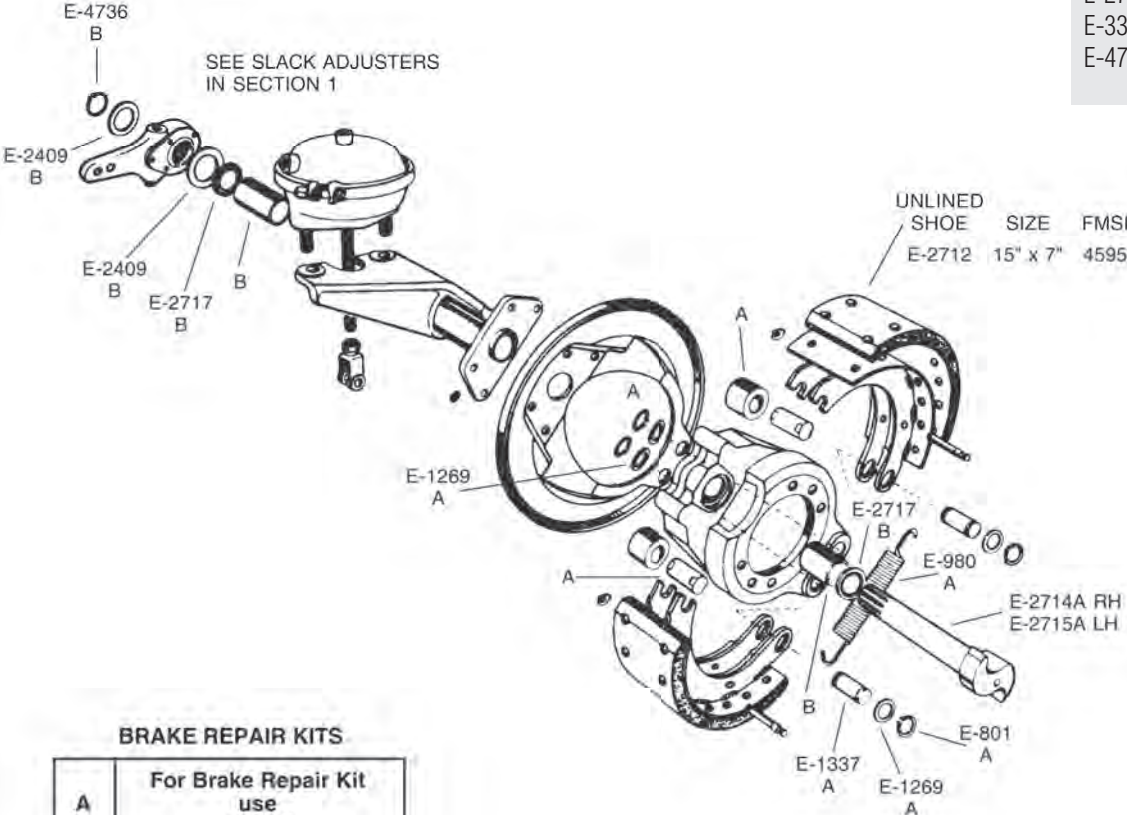

BRAKE REPAIR KITS

A	For Brake Repair Kit use E-2713
B	For Camshaft Repair Kit use E-3354

BENDIX 15" DIAMETER WEDGE BRAKES

TRACTOR STEERING AXLE NON-SERVO

Part	Page
E-1214	1-198
E-1215	1-300
E-1216	1-300
E-1217	1-300
E-1218	1-299
E-1493	1-299
E-1495	1-299
E-1496	1-299
E-1497	1-299
E-2153	1-298
E-2154	1-298
E-2155	1-298
E-2156	1-298
E-2159	1-299
E-2161	1-296
E-2162	1-296
E-2281	1-296
E-2282	1-296
E-2552	1-329
E-2745	1-149

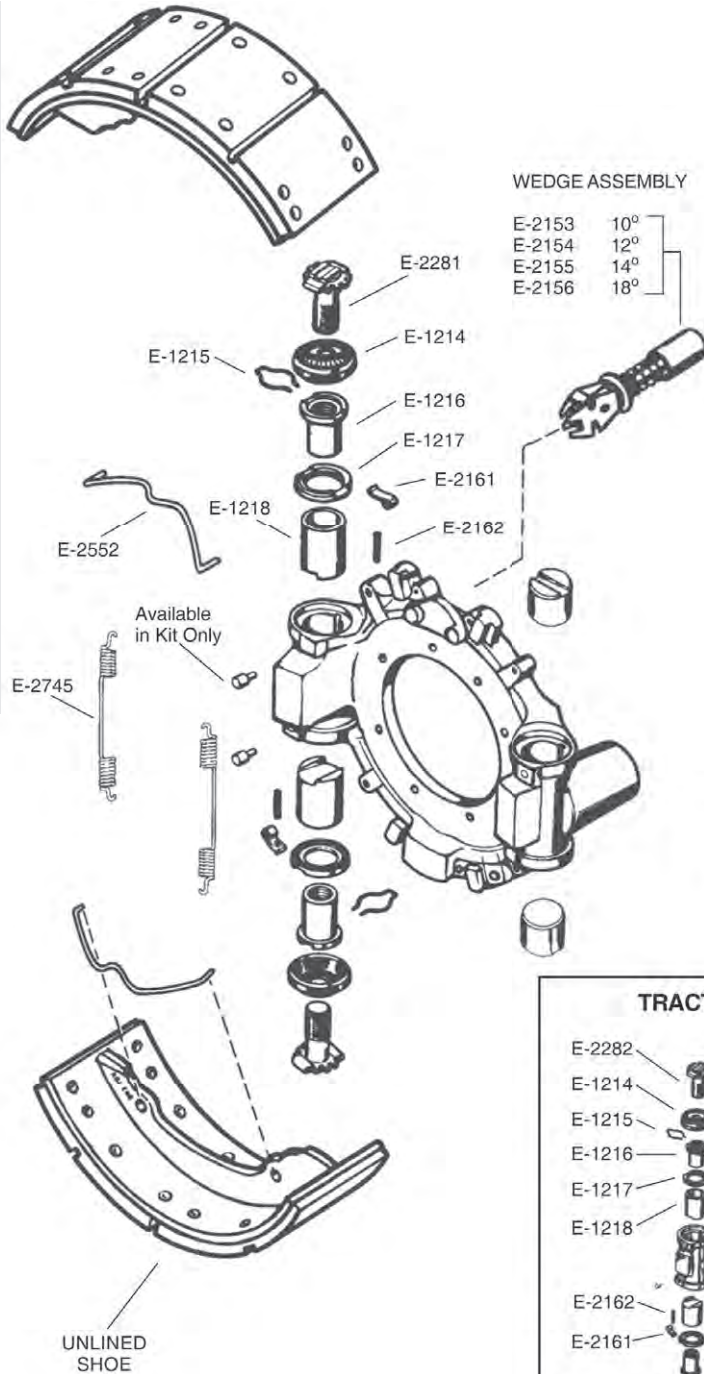

WEDGE ASSEMBLY

E-2153	10°
E-2154	12°
E-2155	14°
E-2156	18°

For Major Rebuild Kit
use
E-2746

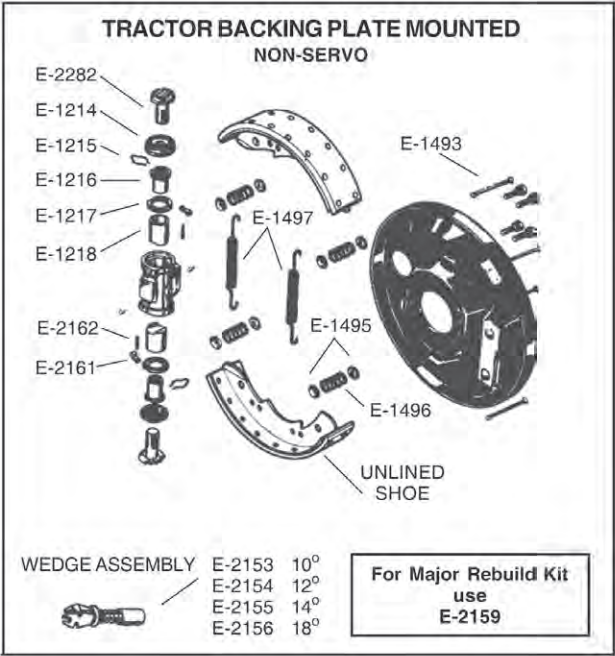

TRACTOR BACKING PLATE MOUNTED NON-SERVO

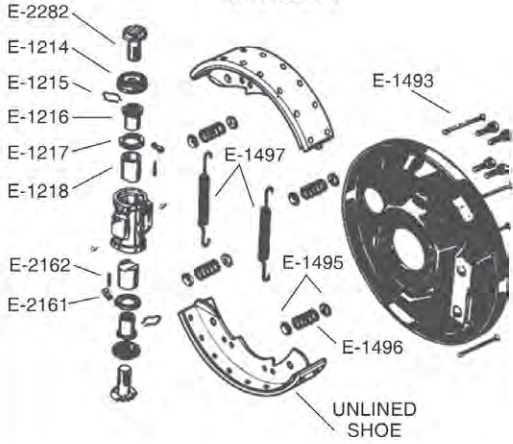

WEDGE ASSEMBLY	
E-2153	10°
E-2154	12°
E-2155	14°
E-2156	18°

For Major Rebuild Kit
use
E-2159

BENDIX 15" DIAMETER WEDGE BRAKES

TRACTOR-TRAILER SPIDER MOUNTED BRAKE

TWIN-PLEX

Part	Page
E-1214	1-198
E-1215	1-300
E-1216	1-300
E-1217	1-300
E-1218	1-299
E-1230	1-298
E-1489	1-157
E-2153	1-298
E-2154	1-298
E-2155	1-298
E-2156	1-298
E-2157	1-299
E-2158	1-299
E-2161	1-296
E-2162	1-296
E-2163	1-149
E-2281	1-296
E-2552	1-329

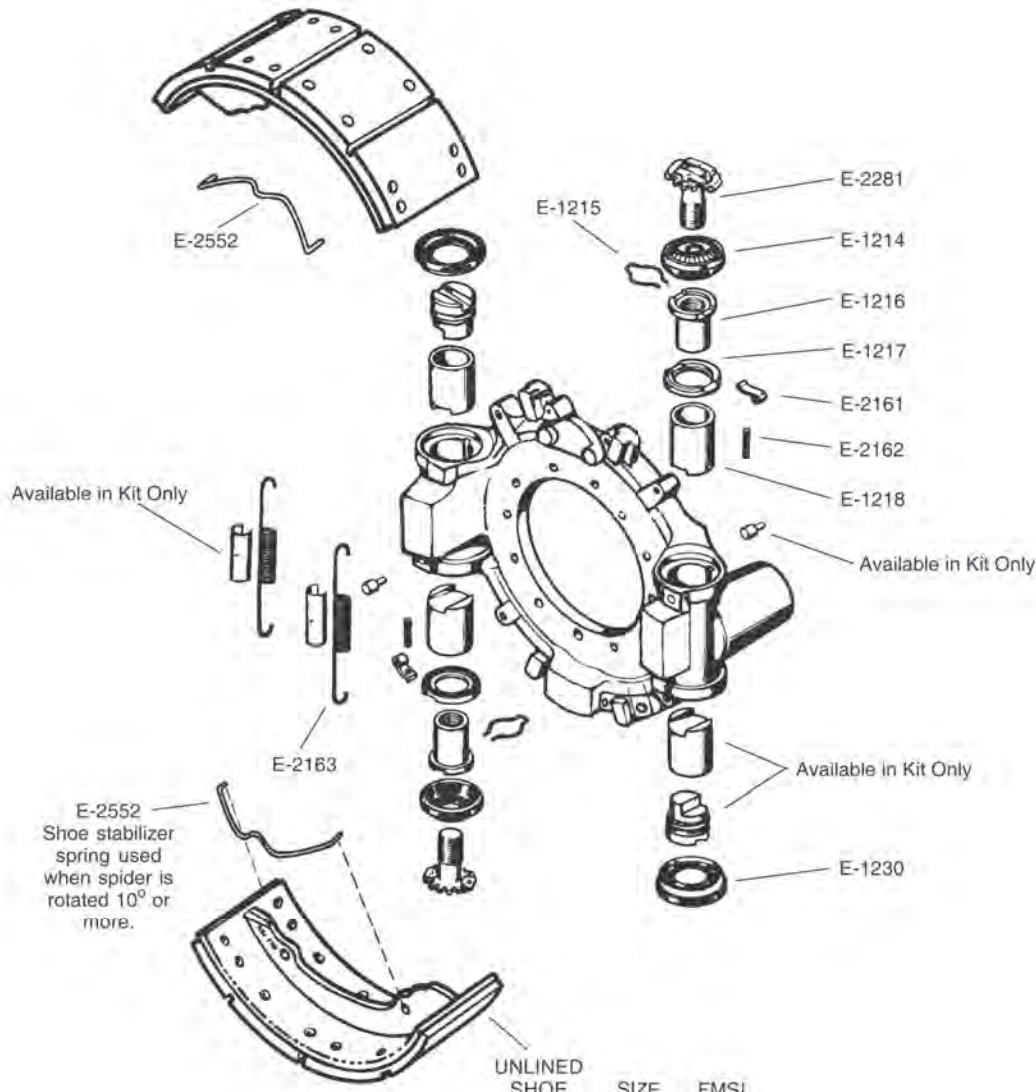

UNLINED SHOE	SIZE	FMSI
E-1489	6"	4605
N/A	7"	4602



WEDGE ASSEMBLY	ANGLE
E-2153	10°
E-2154	12°
E-2155	14°
E-2156	18°

**For Major Rebuild Kit
use
E-2157**

**For Minor Rebuild Kit
use
E-2158**

MERITOR "STOPMASTER" 12 1/4" DIAMETER WEDGE BRAKES

TRAILER 12 1/4" SPIDER MOUNTED BRAKE

PartPage

E-1136	1-302
E-1137	1-302
E-1261	1-304
E-2134	1-302
E-2135	1-302
E-2136	1-302
E-2137	1-302
E-2138	1-302
E-2139	1-302
E-2140	1-304
E-2141	1-304
E-2142	1-304
E-2193	1-306
E-2484	1-301
E-3994	1-303
E-3995	1-303
E-3996	1-301
E-3997	1-301
E-3998	1-301
E-3999	1-301
E-5531	1-301
E-5539	1-303
E-5541	1-303

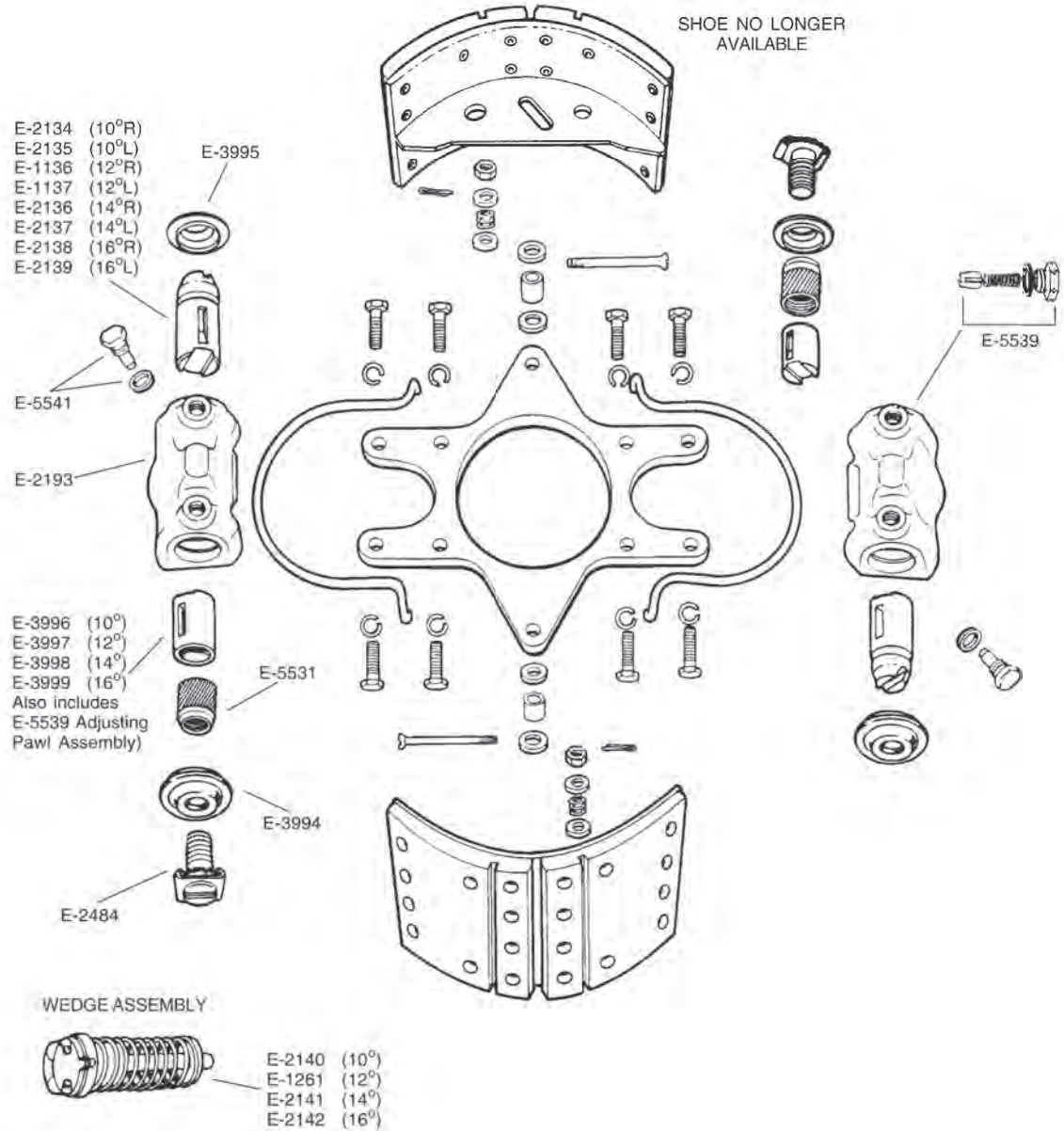
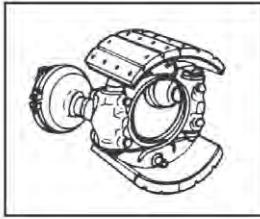

MERITOR "STOPMASTER" 15" DIAMETER WEDGE BRAKES

TRUCK & TRACTOR BACKING PLATE MOUNTED (DUAL ACTUATION)

Part	Page
E-1261	1-304
E-1457	1-157
E-1458	1-148
E-2141	1-304
E-2142	1-304
E-2476	1-149
E-3492	1-301
E-3499	1-301
E-3525	1-306
E-5532	1-303
E-5540	1-303
E-5541	1-303
E-5542	1-307
E-5543	1-307

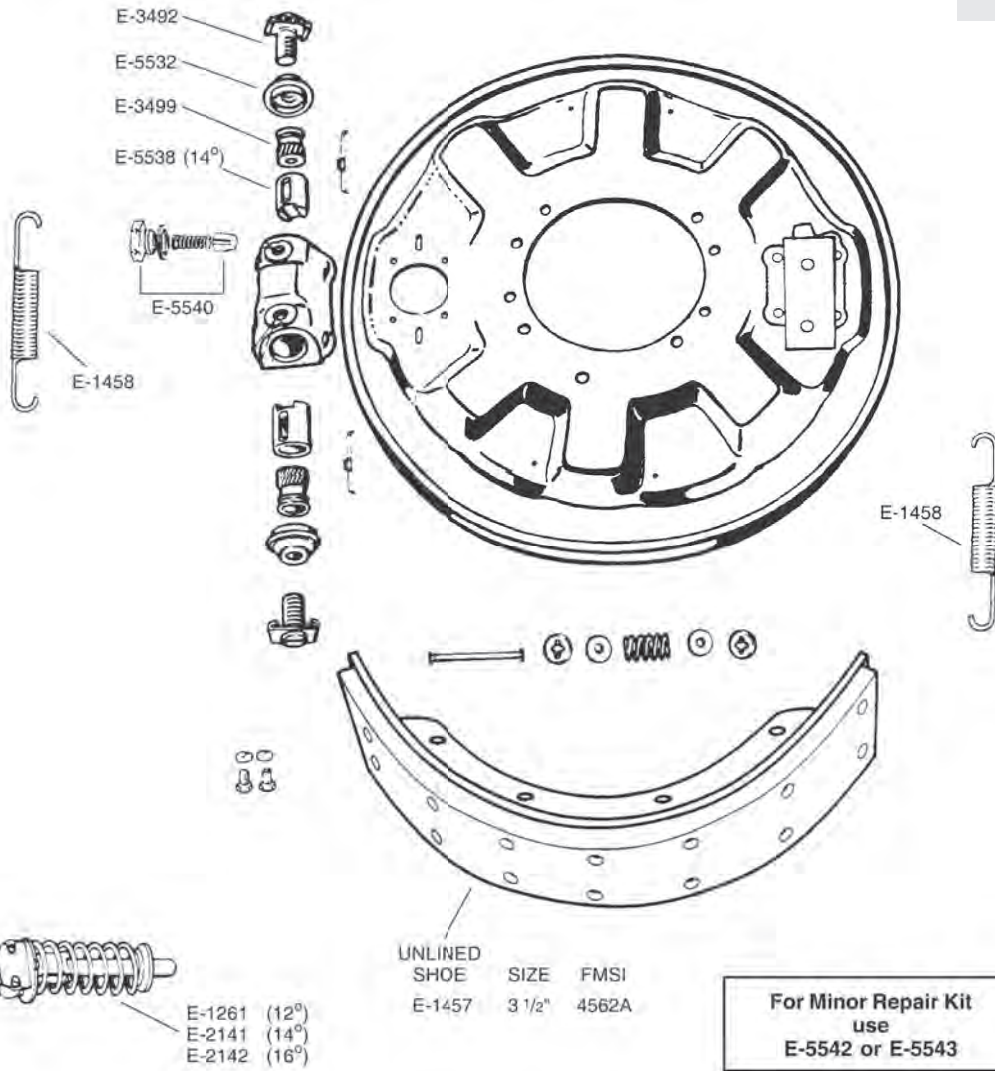
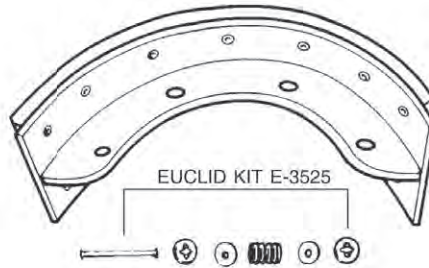
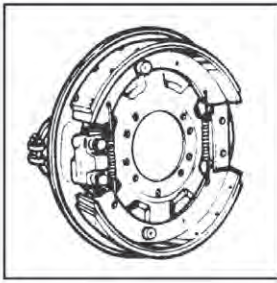

MERITOR "STOPMASTER" 15" DIAMETER WEDGE BRAKES

TRUCK & TRACTOR BACKING PLATE MOUNTED (SINGLE ACTUATION)

Part	Page
E-1261	1-304
E-1457	1-157
E-1458	1-148
E-2141	1-304
E-2142	1-304
E-3492	1-301
E-3499	1-301
E-3525	1-306
E-5532	1-303
E-5538	1-302
E-5540	1-303
E-5542	1-307
E-5543	1-307

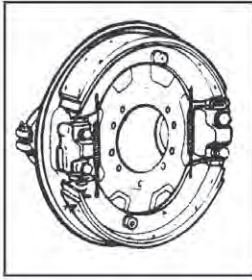

UNLINED SHOE SIZE FMSI
E-1457 3 1/2" 4562A

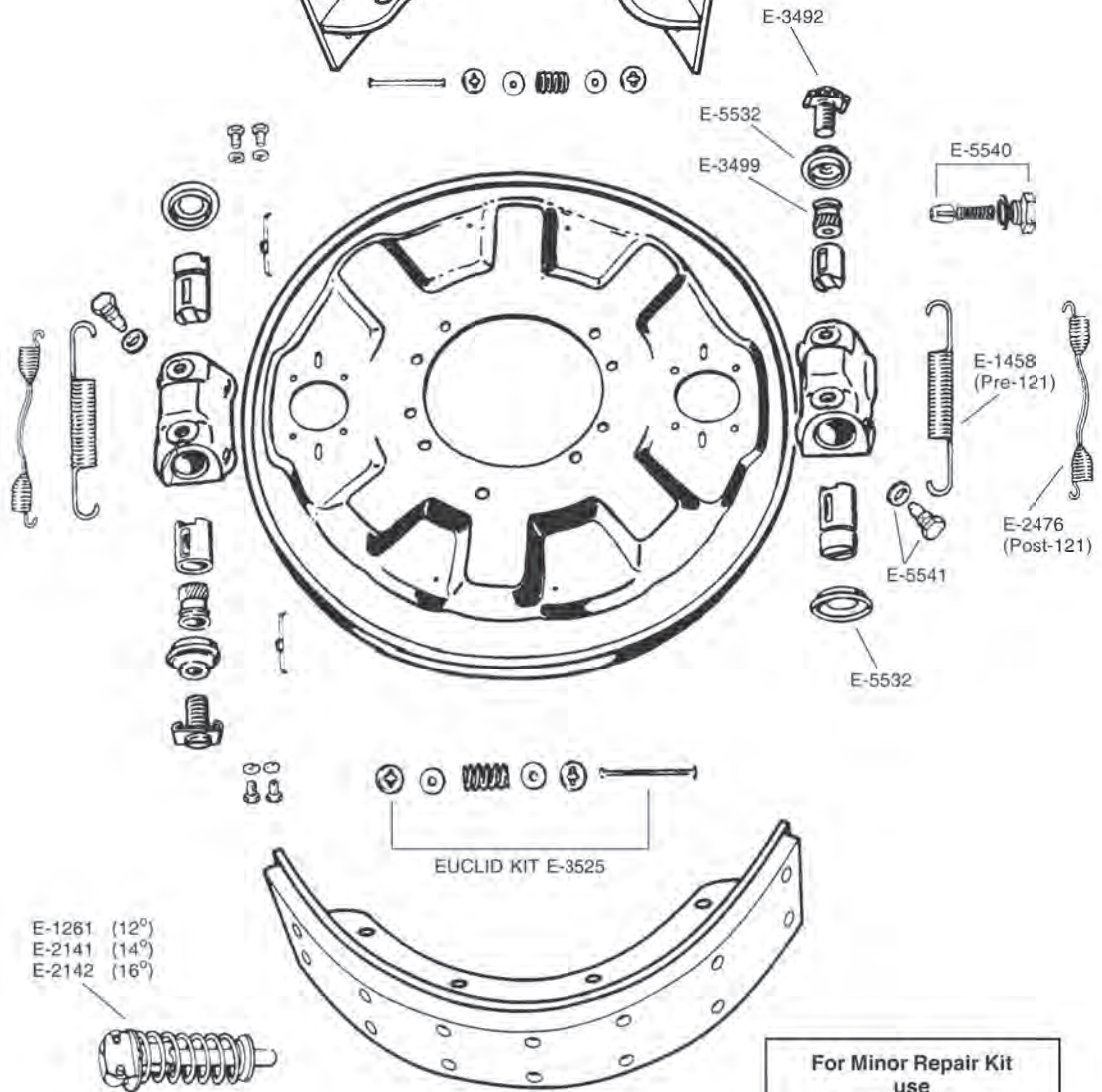

For Minor Repair Kit
use
E-5542 or E-5543

MERITOR "STOPMASTER" 15" DIAMETER RSA WEDGE BRAKES

TRUCK & TRACTOR BACKING PLATE MOUNTED (DUAL ANCHOR PIN)

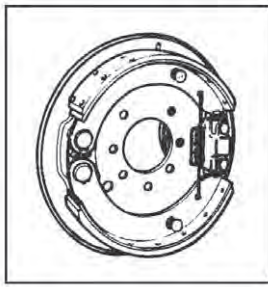

UNLINED SHOE
E-3495 SIZE 4" FMSI 1308

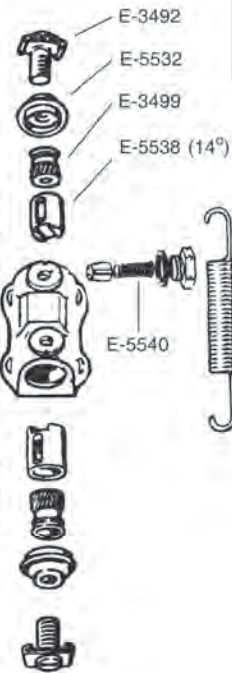
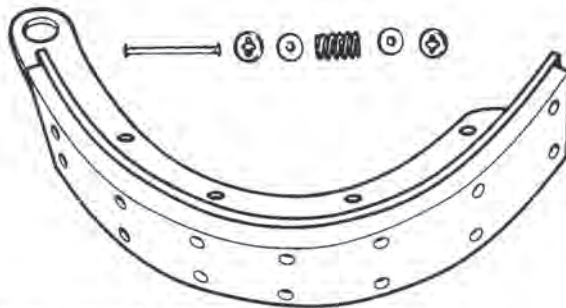
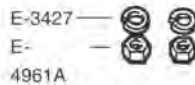
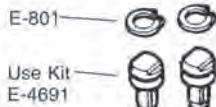
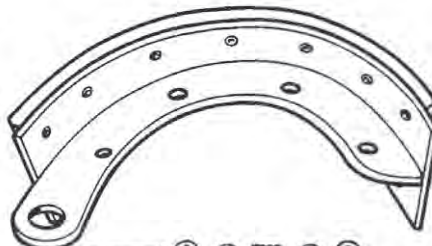

E-1261 (12°)
E-2141 (14°)
E-2142 (16°)



Part	Page
E-801	1-131
E-1261	1-304
E-1458	1-148
E-2141	1-304
E-2142	1-304
E-3424	1-128
E-3427	1-137
E-3492	1-301
E-3495	1-157
E-3499	1-301
E-3525	1-306
E-4961A	1-132
E-5532	1-303
E-5538	1-302
E-5540	1-303
E-5542	1-307
E-5543	1-307

For Minor Repair Kit
use
E-5542 or E-5543

MERITOR "STOPMASTER" 15" DIAMETER WEDGE BRAKES

TRUCK & TRACTOR BOLT-ON SPIDER

Part	Page
E-1136	1-302
E-1137	1-302
E-1139	1-304
E-1261	1-304
E-2134	1-302
E-2135	1-302
E-2136	1-302
E-2137	1-302
E-2138	1-302
E-2139	1-302
E-2140	1-304
E-2141	1-304
E-2484	1-301
E-2522	1-305
E-2689	1-304
E-3994	1-303
E-3995	1-303
E-3996	1-301
E-3997	1-301
E-3998	1-301
E-3999	1-301
E-5531	1-301
E-5539	1-303
E-5541	1-303
E-5544	1-308
E-5545	1-308
E-7211	1-305
E-7212A	1-307
E-7213A	1-307
E-7214A	1-308

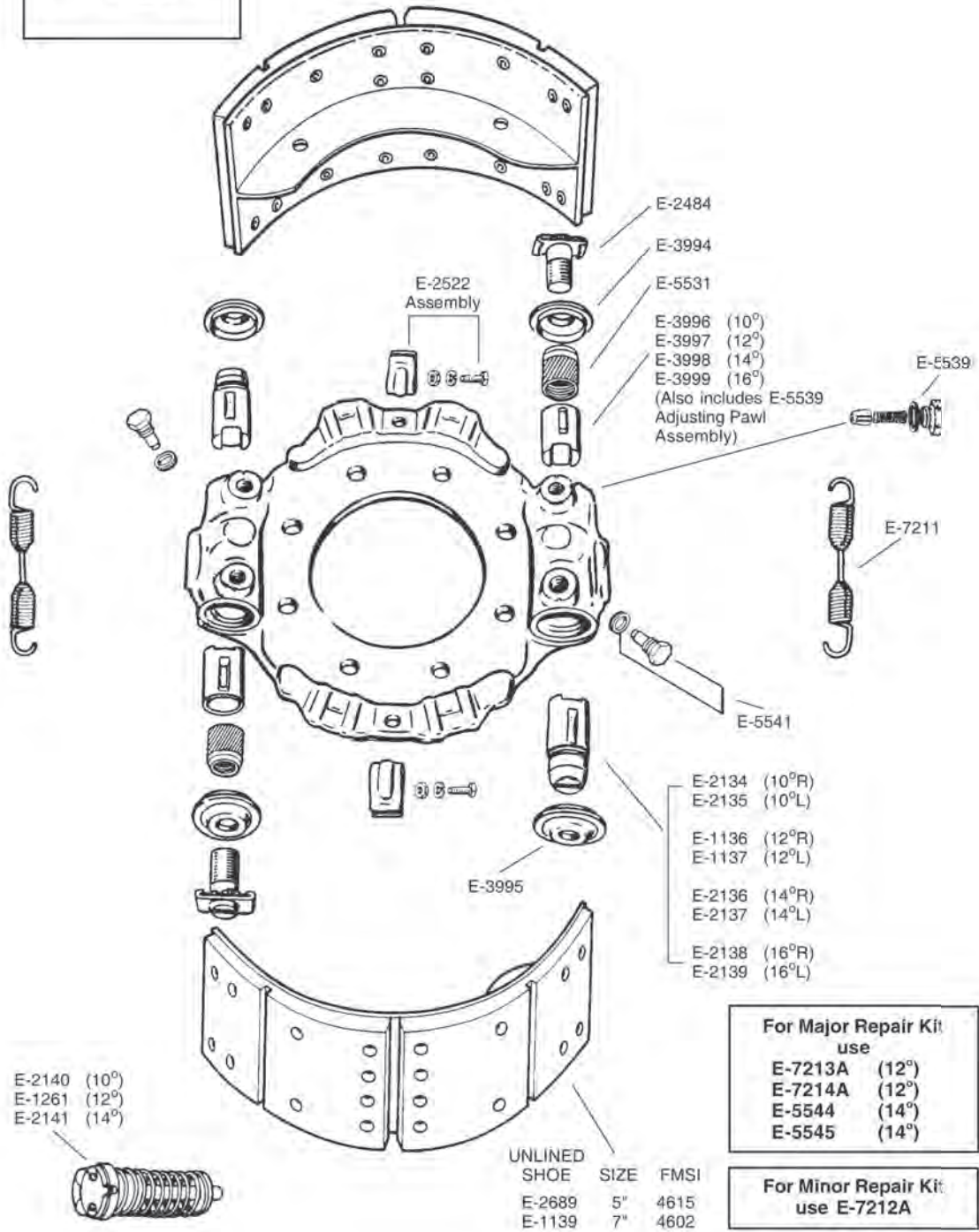
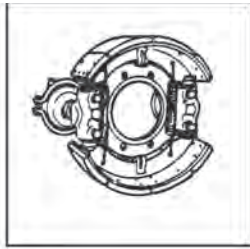

For Major Repair Kit use
E-7213A (12°)
E-7214A (12°)
E-5544 (14°)
E-5545 (14°)

For Minor Repair Kit use E-7212A

MERITOR "STOPMASTER" 15" DIAMETER WEDGE BRAKES

TRUCK & TRACTOR WELD-ON SPIDER WITH BOLT-ON HOUSING

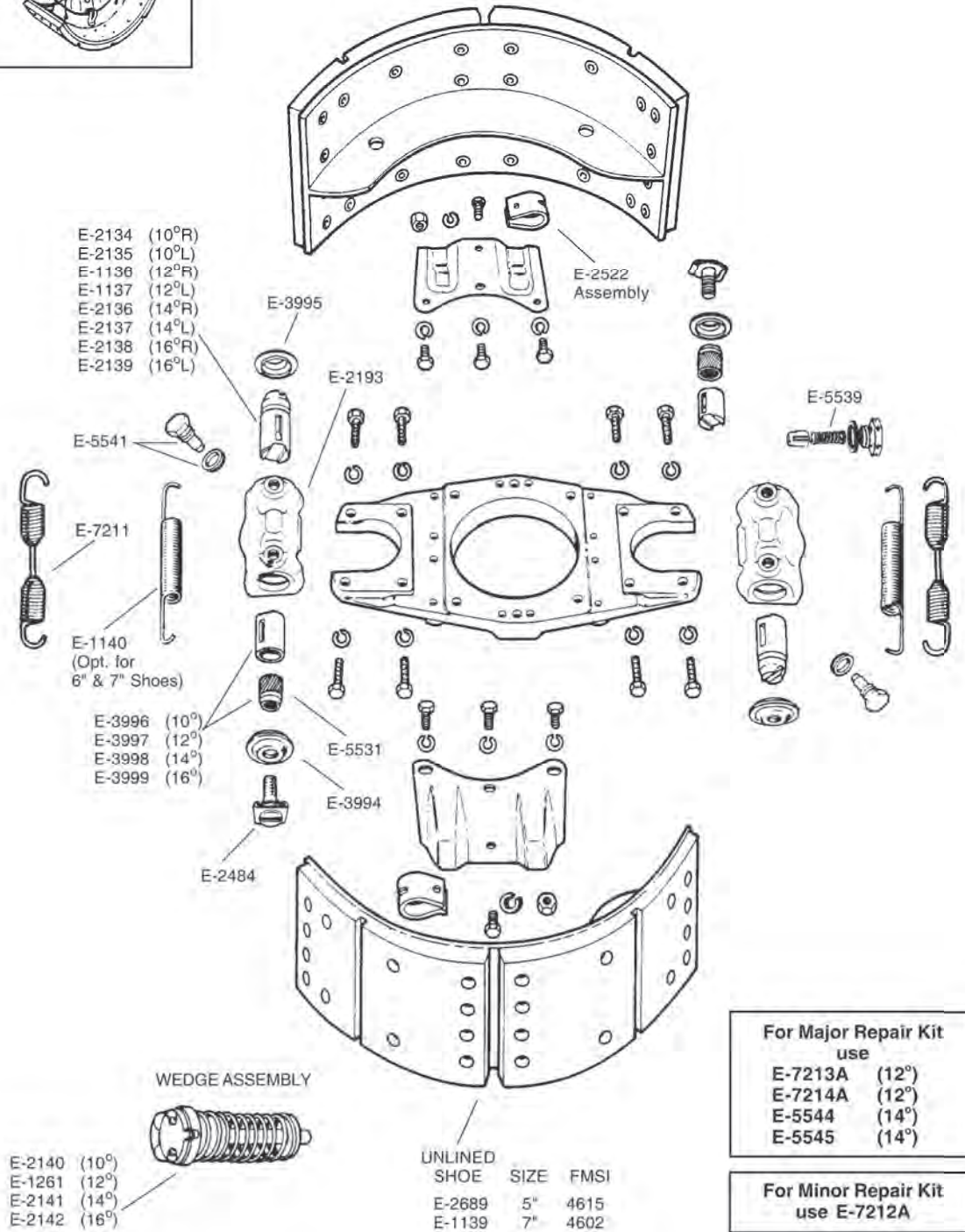
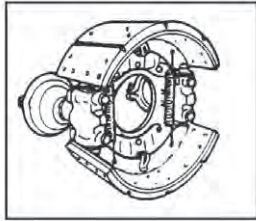

Part	Page
E-1136	1-302
E-1137	1-302
E-1139	1-304
E-1140	1-305
E-1261	1-304
E-2134	1-302
E-2135	1-302
E-2136	1-302
E-2137	1-302
E-2138	1-302
E-2139	1-302
E-2140	1-304
E-2141	1-304
E-2142	1-304
E-2193	1-306
E-2484	1-301
E-2522	1-305
E-2689	1-304
E-3994	1-303
E-3995	1-303
E-3996	1-301
E-3997	1-301
E-3998	1-301
E-3999	1-301
E-5531	1-301
E-5539	1-303
E-5541	1-303
E-5544	1-308
E-5545	1-308
E-7211	1-305
E-7212A	1-307
E-7213A	1-307
E-7214A	1-308

For Major Repair Kit use

E-7213A (12°)
E-7214A (12°)
E-5544 (14°)
E-5545 (14°)

For Minor Repair Kit use E-7212A

EUCLID BRAKE HARDWARE KITS



EUCLID ADVANTAGES

- Delivers both proven stopping performance and extended brake life to reduce maintenance costs
- All parts tested by Meritor to OE replacement specifications
- All parts engineered to manage the brake forces generated for superior performance
- Built-in technology leadership you expect from a global leader in brake manufacturing
- Proven quality control
- XpresswayPlus.com offers:
 - Expert technical support 24/7
 - Order entry/tracking
- Competitively priced to meet your needs
- Leading aftermarket warranty
- For total customer support, call our Customer Care Center 888.725.9355 or in Canada, 800.387.3889

GENUINE BRAKE HARDWARE KIT COMPONENTS

Anchor Pins

Euclid anchor pins are case-hardened for longer life. Euclid MEGA PLUS™ anchor pins are hard chrome or zinc plated for corrosion resistance.



Euclid STOPMATE PLUS™ pins are zinc plated for maximum corrosion resistance.

All Euclid anchor pins provide a close fit between pin and shoe, yet allow the shoe to move freely.

Brake Shoe Rollers

Euclid "Posi Plus" shoe rollers add smooth radius edges to prevent flatspotting on the roller surface. When uneven brake cam pressure occurs, pressure is distributed evenly across the radius-edge surface of the roller to prevent cracks that lead to flat spots.



Euclid "Posi Plus" brake shoe rollers are included in MEGA PLUS and STOPMATE PLUS hardware kits.

Stainless Steel Anchor Pin Bushings

Euclid MEGA PLUS high-grade stainless steel anchor pin bushings feature an exclusive "dimpled" inner surface, which retains lubricant for easier pin removal.



Euclid STOPMATE PLUS kits feature high-grade stainless steel for corrosion resistance.

Brake Return Springs

Shot peening removes surface flaws – important under stress, since any flaws or forming marks become the weakest part of the spring. High-grade wire retains high spring tension for durability.



Euclid MEGA PLUS kits feature only heavy-duty 100-pound tension return springs.

Wire Roller Retainer

Coated to guard against corrosion, which can cause the brake shoe rollers to bind and accelerate camshaft wear.



UNMATCHED SERVICE AND SUPPORT



For complete product information, visit XpresswayPlus.com, our industry-leading online catalog, ordering and tracking system with real-time access to comprehensive parts information resources, including a reference library with complete technical drawings on components and systems.

Our highly trained Customer Care team is equipped with the product specification, warranty and service information needed to deliver the best customer support. Call them at 888-725-9355 or in Canada, call 800-387-3889.

EUCLID BRAKE HARDWARE KIT & UNLINED BRAKE SHOE

QUICK REFERENCE GUIDE

Brake Application	FMSI / Drill#	"Euclid Brake Shoe"	Euclid MEGA+ Hardware Kit	Euclid STOPMATE+ Hardware Kit	"Euclid STOPMATE Hardware Kit"
12-1/4" x 4" Dexter	4700	E-9025	E-2402HD	n/a	n/a
12-1/4" x 5" Dexter Fabricated Shoes	4661C	E-9026	E-2402HD	n/a	n/a
12-1/4" x 5-1/2" Spicer & Standard Forge	4536B	E-2393	E-2402HD	n/a	n/a
12-1/4" x 5-1/2" Spicer & Standard Forge	4544	E-1412A	E-2403HD, E-3374HD	E-9282	n/a
12-1/4" x 5-1/2" Spicer Fabricated Shoes	4536E	E-2393A	E-3373HD	E-9281	n/a
12-1/4" x 5-1/2" Spicer U	4536E	n/a	E-3782	E-9283	n/a
12-1/4" x 7-1/2" Dexter PQ	4591	E-10878	E-10875	n/a	n/a
12-1/4" x 7-1/2" Eaton	4591	E-1398	E-2126	n/a	n/a
12-1/4" x 7-1/2" Meritor Q	4670	E-3491	E-3484	n/a	n/a
12-1/4" x 7-1/2" Spicer & Standard Forge	4607	E-1413A	E-2403HD	n/a	n/a
12-1/4" x 7-1/2" Spicer Fast Change II	4692	E-10763	E-3373HD, E-10757	E-9281	n/a
12-1/4" x 7-1/2" Spicer U	4692	E-5303A	E-5306	n/a	n/a
12-1/4" x 7-1/2" Standard Forge Closed Roller End	4591	E-1398	E-2402HD	n/a	n/a
12-1/4" x 7-1/2" Standard Forge Open Roller End	4692	E-2394A	E-3782	E-9283	n/a
12-1/4" x 7-1/4" Spicer & Standard Forge	4607	E-1413A	E-3374HD	E-9282	n/a
14-1/2" x 10" Meritor Coach	4592A	E-10809, E-10810	E-10869, E-10870	n/a	n/a
14-1/2" x 4" Meritor Coach	4227G	E-10802	E-10841-A, E-10866-A	n/a	n/a
14-1/2" x 5" Meritor Coach	4398B	E-10804	E-10841-A, E-10866-A	n/a	n/a
14-1/2" x 6" Meritor Coach	4228B	E-10803	E-10841-A, E-10866-A	n/a	n/a
14-1/2" x 8" Meritor Coach	4541B	E-10805	E-10867	n/a	n/a
15" x 3-1/2" Meritor T Front	1307	E-3438	E-4691, E-6879	E-7899	E-1308Q, E-1308QMA, E-4691
15" x 3-1/2" Wagner	1280B	n/a	E-2740	n/a	n/a
15" x 4" Bendix	4693	E-7230	n/a	E-7231, E-7232	n/a
15" x 4" Eaton ES Front	1443TT	E-9027	E-5139	n/a	E-1308E
15" x 4" Eaton Front	1308TT	E-5126	E-5139	n/a	E-1308E
15" x 4" Meritor Q Front	1308TT	E-5528	E-3869	E-7899	E-1308Q, E-1308QMA
15" x 4" Meritor Q Plus Front	4702	E-9062	E-9064	n/a	E-4702-KT
15" x 4" Meritor T Front	1308TT	E-3439	E-4691, E-6879	n/a	E-4691
15" x 4" Spicer ES	4729	E-11982	n/a	E-11981	n/a
15" x 5" Meritor Lucas Hydraulic	4528A	E-4018	n/a	n/a	n/a
15" x 5" Meritor Q Plus Front	4703	E-11453	E-9064	n/a	E-4702-KT
15" x 6" Bendix Wedge	4605	n/a	n/a	n/a	n/a
15" x 6" Meritor Lucas Hydraulic	4504	E-4019	n/a	n/a	n/a
15" x 6" Meritor Q Plus Front	4704	E-11454	E-9064	n/a	E-4702-KT
15" x 6" Meritor Stopmaster Wedge	4605	E-1138	n/a	n/a	n/a
15" x 6" Spicer Reduced Envelope	4716	E-9140	E-9141	n/a	n/a
15" x 6" Wagner	4596	n/a	E-2713	n/a	n/a
15" x 7" Meritor Lucas Hydraulic	4505	E-4020	n/a	n/a	n/a
15" x 7" Meritor Q Plus Front	4705	E-11455	E-9064	n/a	E-4702-KT
15" x 7" Meritor Stopmaster Wedge	4602	E-1139	n/a	n/a	n/a
15" x 7" Wagner	4597	n/a	E-2713	n/a	n/a

MB = Minus Anchor Pin Bushings
 HD = Heavy Duty
 n/a = Not Available

EUCLID BRAKE HARDWARE KIT & UNLINED BRAKE SHOE

QUICK REFERENCE GUIDE

Brake Application	FMSI / Drill#	"Euclid Brake Shoe"	Euclid MEGA+ Hardware Kit	Euclid STOPMATE+ Hardware Kit	"Euclid STOPMATE Hardware Kit"
15" x 8-5/8" Meritor Q Plus Front	4710	E-11456	n/a	n/a	n/a
15" x 8-5/8" Spicer Reduced Envelope	4717	E-9036	E-9039	n/a	n/a
16-1/2" x 10" Meritor P	4567	n/a	E-1816HD, KIT-4HD	E-1816S, E-1816SHD, KIT-4S, KIT-4SHD	E-4515P, E-4515PHD
16-1/2" x 10" Spicer Cast Shoes	4552B	n/a	KIT-1	n/a	n/a
16-1/2" x 4" Meritor P	4549C	E-2686	KIT-4HD, E-1816HD	KIT-4S, KIT-4SHD, E-1816S, E-1816SHD	E-4515P, E-4515PHD
16-1/2" x 4" Meritor Q	4549C	E-2686	E-1816HD	E-1816S, E-1816SHD	E-4515P, E-4515PHD
16-1/2" x 5" Eaton ES	4719	E-10270	E-5481A	E-11318	E-4709ES-N
16-1/2" x 5" Eaton High Mount	4223A	E-2474	E-3801	n/a	n/a
16-1/2" x 5" Eaton Low Mount	4223A	E-1778	E-1887AHD, E-2820	E-1887ASHD	E-4311EHD-N
16-1/2" x 5" Meritor P	4524B	E-2687	E-1816HD, KIT-4HD	E-1816S, E-1816SHD, KIT-4S, KIT-4SHD	E-4515P, E-4515PHD
16-1/2" x 5" Meritor Q for 1.68" Offset Spider with Relocated Retainer Spring Hole	4524B	E-3303	n/a	n/a	n/a
16-1/2" x 5" Meritor Q Plus & Spicer XTRALIFE II	4720	E-10854	E-2769HD, E-9644	E-2769SHD, E-6999SHD, E-3895SHD	E-4515Q-N-NHD-N, E-4515Q-N-NMB-NHD-N, E-4515UHD
16-1/2" X 5" Meritor Q, Spicer Fast Change and Hendrickson Intraax®	4524B	E-3303	E-2769HD, E-9070, E-9644	E-2769S, E-2769SHD, E-6999S, E-6999SHD, E-3895S, E-3895SHD	E-4515Q-N-N, E-4515Q-N-NHD-N, E-4515Q-N-NMB-N, E-4515Q-N-NMB-NHD-N, E-4515U, E-4515UHD
16-1/2" x 5" Meritor Q with Relocated Retainer Spring Hole	4524B	E-3823	E-9644	n/a	n/a
16-1/2" x 5" Spicer ESII	4719	E-10270	E-10760	n/a	n/a
16-1/2" x 6" Eaton High Mount	4317G	E-9509	E-3801	n/a	n/a
16-1/2" x 6" Eaton Low Mount	4317G	E-1777	E-1887AHD, E-2820	E-1887ASHD	E-4311EHD-N
16-1/2" x 6" Meritor P	4514G	E-2684	E-1816HD, KIT-4HD	E-1816S, E-1816SHD, KIT-4S, KIT-4SHD	E-4515P, E-4515PHD
16-1/2" x 6" Meritor Q Plus & Spicer XTRALIFE II	4715	E-10847	E-9644	n/a	n/a
16-1/2" x 6" Meritor Q with Relocated Retainer Spring Hole	4514G	E-9780	E-9644, E-9644	n/a	n/a
16-1/2" X 6" Meritor Q, Spicer Fast Change & Hendrickson Intraax®	4514G	E-3304	E-2769HD, E-9644, E-9070, E-9644	E-2769S, E-2769SHD, E-6999S, E-6999SHD, E-3895S, E-3895SHD	E-4515Q-N-N, E-4515Q-N-NHD-N, E-4515Q-N-NMB-N, E-4515Q-N-NMB-NHD-N, E-4515U, E-4515UHD
16-1/2" x 6" Spicer ESII	4725	E-10271	E-10760	n/a	E-4709ES2-N
16-1/2" x 7" Bendix	4515E	E-7236	n/a	E-7237, E-7238	n/a
16-1/2" x 7" Eaton High Mount	4311J	E-2819	E-3801	n/a	n/a
16-1/2" x 7" Eaton Low Mount	4311J	E-1778	E-1887AHD	E-1887ASHD	E-4311EHD-N
16-1/2" x 7" Fruehauf Pro-Par	4515E	E-2685	E-2121, E-2121HD	E-2121SHD	n/a
16-1/2" x 7" Fruehauf XEM 2nd Generation	4515E	n/a	n/a	E-4880S, E-4880SHD	n/a
16-1/2" x 7" Fruehauf XEM 3rd Generation	4515E	E-3920	E-3710HD	E-3710S, E-3710SHD	E-4515X, E-4515XHD
16-1/2" x 7" Mack Fabricated Shoes	4515G	n/a	E-1607HD	n/a	n/a

MB = Minus Anchor Pin Bushings
 HD = Heavy Duty
 n/a = Not Available

EUCLID BRAKE HARDWARE KIT & UNLINED BRAKE SHOE

QUICK REFERENCE GUIDE

Brake Application	FMSI / Drill#	"Euclid Brake Shoe"	Euclid MEGA+ Hardware Kit	Euclid STOPMATE+ Hardware Kit	"Euclid STOPMATE Hardware Kit"
16-1/2" x 7" Meritor for Fruehauf (F5)	4515G	n/a	E-2769HD	E-2769S, E-2769SHD, E-6999S, E-6999SHD,	E-4515Q-N-N, E-4515Q-N-NMB-N
16-1/2" x 7" Meritor P	4515G	E-2241	E-1816HD, KIT-4HD	E-1816S, E-1816SHD, KIT-4S, KIT-4SHD	E-4515P, E-4515PHD
16-1/2" x 7" Meritor P Cast	4515G	n/a	n/a	n/a	n/a
16-1/2" x 7" Meritor P For Mack	4625B	E-4902	E-2675HD	n/a	n/a
16-1/2" x 7" Meritor Q Heavy Duty	4515H	E-5092	E-5086	n/a	n/a
16-1/2" x 7" Meritor Q Plus Heavy Duty	4707	n/a	E-2769HD	E-2769SHD, E-6999SHD	E-4515Q-N-NHD-N, E-4515Q-N-NMB-NHD-N
16-1/2" x 7" Meritor Q Plus Spicer XTRALIFE II & Hendrickson Intraax®	4707	E-5503	E-2769HD, E-6999SHD	E-2769SHD, E-6999SHD, E-3895SHD	E-4515Q-N-NHD-N, E-4515Q-N-NMB-NHD-N, E-4515UHD
16-1/2" x 7" Spicer & Standard Forge Cast Shoes	4468	n/a	KIT-1	n/a	n/a
16-1/2" x 7" Spicer Cast Shoe	4708	E-9040	E-9048	n/a	n/a
16-1/2" x 7" Spicer ES	4709	E-5480	E-5481A	E-11318	E-4709ES-N
16-1/2" x 7" Spicer ES Retrofit for Fruehauf	4708	E-8922	E-8923	n/a	n/a
16-1/2" x 7" Spicer ES Retrofit for Meritor	4708	E-8924	E-8925	n/a	n/a
16-1/2" x 7" Spicer ESII	4709	E-10272	E-10244	E-11319, E-10244S	E-4709ES2-N
16-1/2" X 7" Spicer Fast Change XLII and Hendrickson Intraax®	4515E	E-2778	E-2769HD	E-2769S, E-2769SHD, E-6999S, E-6999SHD,	E-4515Q-N-N, E-4515Q-N-NHD-N, E-4515Q-N-NMB-N, E-4515Q-N-NMB-NHD-N
16-1/2" x 7" Spicer Severe Duty	4708	E-9049	E-9052	n/a	n/a
16-1/2" x 7" Spicer XL	4701	n/a	E-5515	n/a	n/a
16-1/2" x 8" Meritor Q	4644B	n/a	E-2769HD	E-2769SHD, E-6999SHD	E-4515Q-N-NHD-N, E-4515Q-N-NMB-NHD-N
16-1/2" x 8" Meritor Q Plus	4718	E-10850	E-2769HD, E-6999SHD	E-2769SHD, E-6999SHD, E-3895SHD	E-4515Q-N-NHD-N, E-4515Q-N-NMB-NHD-N, E-4515UHD
16-1/2" x 8-5/8" Eaton	4674	E-9054	E-1887AHD	E-1887ASHD	n/a
16-1/2" x 8-5/8" Fruehauf XEM3	4551B	E-3713	E-3710HD	E-3710S, E-3710SHD	E-4515X, E-4515XHD
16-1/2" x 8-5/8" Meritor P	4551B	E-5239	E-1816HD, KIT-4HD	E-1816S, E-1816SHD, KIT-4S, KIT-4SHD	E-4515P, E-4515PHD
16-1/2" x 8-5/8" Meritor Q	4551B	E-3522	E-2769HD	E-2769S, E-2769SHD, E-6999S, E-6999SHD, E-3895S, E-3895SHD	E-4515Q-N-N, E-4515Q-N-NHD-N, E-4515Q-N-NMB-N, E-4515Q-N-NMB-NHD-N, E-4515U, E-4515UHD
16-1/2" x 8-5/8" Meritor Q Plus, Spicer XTRALIFE II & Hendrickson Intraax®	4711	E-10844	E-2769HD	E-2769SHD, E-6999SHD, E-3895SHD	E-4515Q-N-NHD-N, E-4515Q-N-NMB-NHD-N, E-4515UHD
16-1/2" x 8-5/8" Spicer ESII	4726	E-10273	E-10244	E-11319, E-10244S	E-4709ES2-N
16-1/4" x 3-1/2" Meritor T	4561B	E-3441	E-4692	n/a	n/a
18" x 7" Eaton Single Anchor Pin	4527B	E-2801	E-2821	n/a	n/a
18" x 7" Meritor Cast Iron Shoes	4669	E-4902	E-3992	n/a	n/a
18" x 7" Meritor P Cast Shoes	4471B	E-4902	E-3518	n/a	n/a
18" x 7" Spicer & Standard Forge Fabricated Shoes	4284	n/a	E-5499	n/a	n/a

MB = Minus Anchor Pin Bushings
 HD = Heavy Duty
 n/a = Not Available

BRAKE REPAIR KITS

E-3374HD

MEGA PLUS

CONVERT SPICER (DANA) 12-1/4" BRAKE FROM CAST TO FAB SHOES

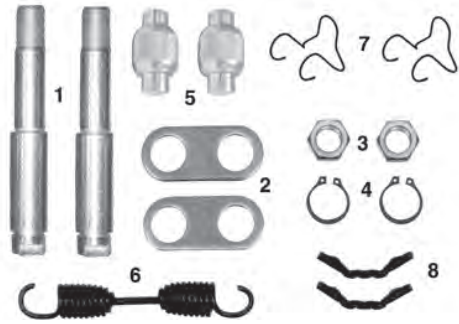

ITEM	QTY	EUCLID NO.	DESCRIPTION	APPLICATION & GENERAL INFORMATION
1	2	E-2414	Brake Shoe Anchor Pin	Contains Euclid's own design anchor pin (E-2414) that allows fabricated steel shoes to be used with Std. Forge's bolt-on Spider for Cast Shoes. For use with old style "Fast-Rise" Camshafts only. Contains new Posi-Plus roller. For use with the following Brake Shoes: E-2393A (5-1/2"), E-2394A (7-1/2"). REPLACES: Dayton/Batco 08107501 Dayton/Batco 081129 Haldex CQ67505 Dana/Spicer HK49125 Leland K288 Meritor R507075
2	2	E-2401	Anchor Pin Link	
3	2	E-1107	Anchor Pin Jam Nut	
4	2	E-2392	Anchor Pin Retainer	
5	2	E-11741	Roller	
6	1	E-2398	Return Spring	
7	2	E-3007A	Roller Retainer	
8	2	E-747	Spring Retainer	

E-9282

MEGA PLUS

CONVERT SPICER (DANA) 12-1/4" BRAKE FROM CAST TO FAB SHOES



ITEM	QTY	EUCLID NO.	DESCRIPTION	APPLICATION & GENERAL INFORMATION
1	2	E-2414	Brake Shoe Anchor Pin	Contains Euclid's own design anchor pin (E-2414) that allows fabricated steel shoes to be used with Std. Forge's bolt-on Spider for Cast Shoes. For use with New Style Camshafts. For use with the following Brake Shoes: E-2393A (5-1/2"), E-2394A (7-1/2"). REPLACES: Haldex CQ67506 Leland K338 Meritor R507089
2	2	E-2401	Anchor Pin Link	
3	2	E-1107	Anchor Pin Jam Nut	
4	2	E-2392	Anchor Pin Retainer	
5	2	E-586	Roller	
6	1	E-2398	Return Spring	
7	2	E-539	Roller Retainer	
8	2	E-747	Spring Retainer	

E-2403HD

MEGA PLUS

CONVERT STD. FORGE 12-1/4" BRAKE FROM CAST TO FAB SHOES



ITEM	QTY	EUCLID NO.	DESCRIPTION	APPLICATION & GENERAL INFORMATION
1	2	E-2414	Brake Shoe Anchor Pin	Contains Euclid's own design anchor pin (E-2414) that allows fabricated steel shoes to be used with Std. Forges bolt-on Spider for Cast Shoes. For use with the following Brake Shoe: E-2394 (7-1/2") REPLACES: Dayton/Batco 081075 Dayton/Batco 08107500 Trailmobile 382403HD Dana/Spicer 45A Haldex CQ67503 Haldex CQ67503B Dana/Spicer HK45XLS Leland K50 Meritor R507068
2	2	E-2401	Anchor Pin Link	
3	2	E-1107	Anchor Pin Jam Nut	
4	2	E-2392	Anchor Pin Retainer	
5	2	E-2395	Roller	
6	2	E-2396	Roller Pin	
7	2	E-527	Roller Pin Retainer	
8	1	E-2398	Return Spring	
9	2	E-2399	Retainer	

BRAKE REPAIR KITS

E-10875

MEGA PLUS

DEXTER 12-1/4" "PQ" BRAKE



ITEM	QTY	EUCLID NO.	DESCRIPTION
1	2	E-2766S	Anchor Pin
2	2	E-1893	Anchor Pin Bushing
3	2	E-2767	Retainer Spring
4	1	E-2398	Return Spring
5	2	E-2396	Roller Pin
6	2	E-2395	Roller
7	4	E-527	Roller Pin Retainer
8	2	E-747	Spring Retainer

APPLICATION & GENERAL INFORMATION

For use with the following Dexter 12-1/4" "PQ" Brake Shoes:
E-10876, E-10877, E-10878
REPLACES:
Dayton/Batco 08104700
Dana/Spicer HK47XLS-150
Leland K353
Leland K369
Sirco LB3D
Meritor R507095

E-2126

MEGA PLUS

EATON 12-1/4" SINGLE ANCHOR PIN BRAKE



ITEM	QTY	EUCLID NO.	DESCRIPTION
1	1	E-1403	Anchor Pin
2	2	E-580	Camshaft Spacer Washer
3	1	E-526	Camshaft Lock Ring
4	2	E-1406	Roller
5	1	E-937	Locknut
6	1	E-1402	Return Spring
7	2	E-1400	Return Spring
8	1	E-3975	Lock Washer

APPLICATION & GENERAL INFORMATION

For use with the following Brake Shoe: E-1398 (7-1/2")
REPLACES:
Dayton/Batco 081076
Dayton/Batco 08107600
Trailmobile 382126
Dana/Spicer 40A
Haldex CQ67388
Dana/Spicer HK40
Leland K106
Leland L1209
Sirco LB4
Meritor R507000
Dana/Spicer TA40A

E-2286

MEGA PLUS

FRUEHAUF "PROPAR" 12-1/4" BRAKE



ITEM	QTY	EUCLID NO.	DESCRIPTION
1	2	E-609	Anchor Pin
2	2	NSS*	Roll Pin
3	2	E-920	Anchor Pin Bushing
4	2	E-747	Spring Retainer
5	2	E-1581	Retainer
6	2	E-1582	Roller
7	1	E-1583	Return Spring

APPLICATION & GENERAL INFORMATION

For use with the following Brake Shoe: E-1580 (8")
REPLACES:
Dayton/Batco 081077
Dayton/Batco 08107700
Trailmobile 382286
Dana/Spicer 41A
Haldex CQ67394
Leland K105
Sirco LB5
Fruehauf MBCBK0015
Meritor R507005
Dana/Spicer TA41A

*Not Sold Separately

BRAKE REPAIR KITS

E-3484 MEGA PLUS



MERITOR 12-1/4" "Q" BRAKE

ITEM	QTY	EUCLID NO.	DESCRIPTION
1	2	E-2766S	Anchor Pin
2	2	E-1893	Anchor Pin Bushing
3	2	E-2767	Retainer Spring
4	1	E-3481A	Return Spring
5	2	E-3482	Roller Pin
6	2	E-3483	Roller
7	4	E-527	Roller Pin Retainer
8	2	E-747	Spring Retainer

APPLICATION & GENERAL INFORMATION

For use with the following Brake Shoe: E-3491 (7-1/2")
REPLACES:
 Dayton/Batco 081093
 Dayton/Batco 08109300
 Trailmobile 383484
 Dana/Spicer 44A
 Haldex CQ67395
 Dana/Spicer HK44XLS
 Leland K154
 Meritor KIT8004
 Sirco LB3
 Fruehauf MBCBK0024
 Meritor R508004

E-10756 MEGA PLUS

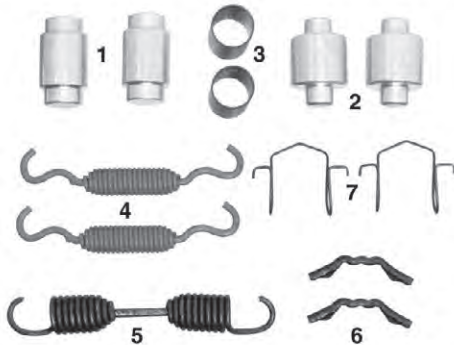

SPICER (DANA) 12-1/4" BRAKE WITH FABRICATED SHOES

ITEM	QTY	EUCLID NO.	DESCRIPTION
1	2	E-2766S	Anchor Pin
2	2	E-586	Roller
3	2	E-1893S	Anchor Pin Bushing
4	2	E-2767	Retainer Spring
5	1	E-2398	Return Spring
6	2	E-747	Spring Retainer
7	2	E-539	Roller Retainer

APPLICATION & GENERAL INFORMATION

For use on Post 11/1/96 spiders that use stepped anchor pins (Spicer 7-1/2" Brake Shoe No. M12WN127-X). This 12-1/4" brake utilizes many components used on the standard 16-1/2" "Fast Change Brake. For use with "0794" Camshafts only.
REPLACES:
 Dayton/Batco 08104900
 Dayton/Batco 08114900
 Haldex CQ67437
 Leland K373
 Sirco LB10
 Meritor R507092

E-14539 MEGA PLUS

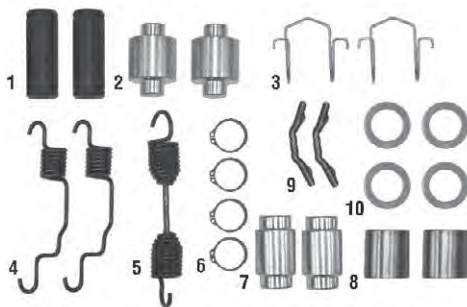

SPICER (DANA) 12-1/4" BRAKE WITH FABRICATED SHOES FOR ABS

ITEM	QTY	EUCLID NO.	DESCRIPTION
1	2	NSS*	Anchor Pin
2	2	E-586	Roller
3	2	NSS*	Roller Retainer
4	2	E-14657	Retainer Spring
5	1	NSS*	Return Spring
6	4	E-2392	Spring Retainer
7	2	E-2766S	Pin
8	2	E-1893S	Bushing
9	2	E-747	Retainer
10	4	E-2391	Washer

APPLICATION & GENERAL INFORMATION

For use on on Pre 11/1/96 and Post 11/1/12 brakes. This 12-1/4" brake utilizes many components used on the standard 16-1/2" "Fast Change Brake. For use with "0794" Camshafts only.
REPLACES:
 Bendix/Spicer HK49-150
 Haldex CQ67437
 Meritory R507017

*Not Sold Separately

BRAKE REPAIR KITS

E-10757

MEGA PLUS

SPICER (DANA) 12-1/4" BRAKE WITH FABRICATED SHOES



ITEM	QTY	EUCLID NO.	DESCRIPTION
1	2	E-2390	Anchor Pin
2	2	E-586	Roller
3	2	E-2389	Anchor Pin Bushing
4	4	E-2391	Anchor Pin Washer
5	4	E-2392	Anchor Pin Retainer
6	2	E-2767	Retainer Spring
7	1	E-2398	Return Spring
8	2	E-747	Spring Retainer
9	2	E-539	Roller Retainer

APPLICATION & GENERAL INFORMATION

Retrofit Kit for use of Spicer 7-1/2" Brake Shoe No. M12WN127-X on Pre 11/1/96 spiders that use straight anchor pins. For use with "0794" Camshafts only.
 REPLACES:
 Dayton/Batco 08105000
 Sirco LB11
 Meritor R507093

E-3373HD

MEGA PLUS

SPICER (DANA) 12-1/4" BRAKE WITH FABRICATED SHOES



ITEM	QTY	EUCLID NO.	DESCRIPTION
1	2	E-2390	Anchor Pin
2	4	E-2391	Anchor Pin Washer
3	4	E-2392	Anchor Pin Retainer
4	2	E-11741	Roller
5	1	E-2398	Return Spring
6	2	E-2389	Anchor Pin Bushing
7	2	E-3007A	Roller Retainer
8	2	E-747	Spring Retainer

APPLICATION & GENERAL INFORMATION

For use with Old Style "Fast-Rise" Camshafts only. Contains new Posi-Plus roller. For use with the following Brake Shoes: E-2393A (5-1/2"), E-2394A (7-1/2")
 REPLACES:
 Dayton/Batco 08107401
 Dayton/Batco 081128
 Trailmobile 383373HD
 Haldex CQ3373HD
 Dana/Spicer HK48XLS125
 Leland K277
 Sirco LB2
 Meritor R507074

E-9281

MEGA PLUS

SPICER (DANA) 12-1/4" BRAKE WITH FABRICATED SHOES



ITEM	QTY	EUCLID NO.	DESCRIPTION
1	2	E-2390	Anchor Pin
2	4	E-2391	Anchor Pin Washer
3	4	E-2392	Anchor Pin Retainer
4	2	E-586	Roller
5	1	E-2398	Return Spring
6	2	E-2389	Anchor Pin Bushing
7	2	E-539	Roller Retainer
8	2	E-747	Spring Retainer

APPLICATION & GENERAL INFORMATION

For use with the following Brake Shoes: E-2393A (5-1/2"), E-2394A (7-1/2")
 REPLACES:
 Haldex CQ67405
 Dana/Spicer HK48XLS150
 Leland K335
 Sirco LB9
 Meritor R507088

BRAKE REPAIR KITS

E-3782

MEGA PLUS

SPICER (DANA) 12-1/4" NEW STYLE "U" BRAKE



ITEM	QTY	EUCLID NO.	DESCRIPTION
1	2	E-5304	Anchor Pin
2	2	E-11741	Roller
3	2	E-3007A	Roller Retainer
4	1	E-2398	Return Spring
5	2	E-747	Spring Retainer
6	1	E-5305	Retainer Spring

APPLICATION & GENERAL INFORMATION

For use with Old Style "Fast-Rise" Camshafts only. Contains new Posi-Plus roller. For use with the following Brake Shoe: E-5303A (7-1/2")
 REPLACES:
 Dayton/Batco 08105105
 Dayton/Batco 081146
 Trailmobile 383782
 Dana/Spicer 47A
 Haldex CQ69002
 Dana/Spicer HK47XLS125
 Leland K137
 Leland K279
 Sirco LB6
 Meritor R507076

E-9283

MEGA PLUS

SPICER (DANA) 12-1/4" NEW STYLE "U" BRAKE



ITEM	QTY	EUCLID NO.	DESCRIPTION
1	2	E-5304	Anchor Pin
2	2	E-586	Roller
3	2	E-539	Roller Retainer
4	1	E-2398	Return Spring
5	2	E-747	Spring Retainer
6	1	E-5305	Retainer Spring

APPLICATION & GENERAL INFORMATION

For use with New Style Camshafts E-9263 through E-9280.
 REPLACES:
 Trailmobile 389283
 Haldex CQ69006
 Dana/Spicer HK47XLS150
 Leland K336
 Sirco LB8
 Meritor R507090

E-5306

MEGA PLUS

SPICER (DANA) 12-1/4" OLD STYLE "U" BRAKE



ITEM	QTY	EUCLID NO.	DESCRIPTION
1	2	E-5304	Anchor Pin
2	2	E-2395	Roller
3	2	E-2396	Roller Pin
4	1	E-2398	Return Spring
5	2	E-2399	Retainer
6	2	E-527	Roller Pin Retainer
7	1	E-5305	Retainer Spring

APPLICATION & GENERAL INFORMATION

For use with the old style Brake Shoe: E-5303 (7-1/2") which is No Longer Available.
 REPLACES:
 Dayton/Batco 081051
 Dayton/Batco 08105100
 Trailmobile 385306
 Haldex CQ67396
 Sirco LB7
 Meritor R507078

BRAKE REPAIR KITS

E-2030HD

MEGA PLUS

SPICER (DANA) and STD. FORGE 12-1/4" BRAKE WITH CAST SHOES



ITEM	QTY	EUCLID NO.	DESCRIPTION
1	2	E-2029	Anchor Pin
2	1	NSS*	Anchor Pin Link
3	2	E-10776	Anchor Pin Lock Ring
4	2	E-1107	Anchor Pin Jam Nut
5	2	E-2101	Return Spring
6	2	E-1808	Brake Shoe Bushing
7	2	E-2176	Roller
8	2	E-501	Roller Pin
9	2	E-773	Roller Pin Set Screw
10	2	E-1106	Anchor Pin Lock Washer

APPLICATION & GENERAL INFORMATION

For use with the following Brake Shoes: E-1412A (5-1/2"), E-1413A (7-1/2")
 REPLACES:
 Dayton/Batco 081073
 Dayton/Batco 08107300
 Dayton/Batco 081422
 Trailmobile 21K62
 Trailmobile 382030HD
 Dana/Spicer 42A
 Haldex CQ67397
 Dana/Spicer HK45XLS
 Dana/Spicer M10LK105X
 Meritor R507014
 Dana/Spicer TA42A

E-2402HD

MEGA PLUS

STANDARD FORGE 12-1/4" BRAKE WITH FABRICATED SHOES



ITEM	QTY	EUCLID NO.	DESCRIPTION
1	2	E-2390	Anchor Pin
2	4	E-2391	Anchor Pin Washer
3	4	E-2392	Anchor Pin Retainer
4	2	E-2395	Roller
5	2	E-2396	Roller Pin
6	2	E-527	Roller Pin Retainer
7	1	E-2398	Return Spring
8	2	E-2399	Retainer
9	2	E-2389	Anchor Pin Bushing
10	2	E-1106	Anchor Pin Lock Washer

APPLICATION & GENERAL INFORMATION

For use with the following Brake Shoes: E-9025 (4"), E-9026 (5"), E-2393 (5-1/2"), E-2394 (7-1/2")
 REPLACES:
 Dayton/Batco 081074
 Dayton/Batco 08107400
 Eaton 125766
 Trailmobile 382402HD
 Dana/Spicer 43A
 Eaton 5-2244
 Eaton 52244B
 Haldex CQ67398
 Dana/Spicer HK43XLS
 Leland K352
 Leland K69
 Sirco LB1
 Dana/Spicer M12LK101X
 Meritor R507015

*Not Sold Separately

BRAKE REPAIR KITS

E-1812

MEGA PLUS

STD. FORGE 12-1/4" BRAKE WITH FLAT HEAD CAMSHAFTS



ITEM	QTY	EUCLID NO.	DESCRIPTION	APPLICATION & GENERAL INFORMATION
1	2	E-1813	Brake Shoe Anchor Pin	For old style cast brake with flat head camshafts. Cannot change to "S" cam. Shoe no longer available. REPLACES: Dayton/Batco 081072 Meritor R507067
2	1	NSS*	Anchor Pin Link	
3	2	E-1106	Anchor Pin Lock Washer	
4	2	E-1107	Anchor Pin Jam Nut	
5	2	E-1025	Return Spring	
6	2	E-1808	Brake Shoe Bushing	
7	2	E-947	Brake Shoe Wear Plate	
8	2	NSS*	Screw	

E-10867

MEGA PLUS

MERITOR COACH 14-1/2" "W" SERIES BRAKE



ITEM	QTY	EUCLID NO.	DESCRIPTION	APPLICATION & GENERAL INFORMATION
1	1	E-10826	Return Spring	For use with the following Meritor Coach 14-1/2" x 8" "W" Series Brake Shoe, Type 1: E-10805 (8") REPLACES:
2	2	E-10828	Anchor Pin Bushing	
3	2	E-4961A	3/4"-16 Lock Nut	
4	2	E-10823	Roller	
5	2	E-10831	Anchor Pin Washer	
6	2	E-10832	Anchor Pin Washer	

E-10869

MEGA PLUS

MERITOR COACH 14-1/2" "W" SERIES BRAKE DRIVE AXLE



ITEM	QTY	EUCLID NO.	DESCRIPTION	APPLICATION & GENERAL INFORMATION
1	2	E-10828	Anchor Pin Bushing	For use with the following Meritor Coach 14-1/2" x 10" "W" Series Brake Shoe, Type 1 and Type 3: E-10810 (10") REPLACES:
2	2	E-4961A	3/4"-16 Lock Nut	
3	1	E-10826	Return Spring	
4	2	E-10824	Roller	
5	2	E-5095	Camshaft Spacer Washer	
6	2	E-10833	Anchor Pin Washer	
7	2	E-10865	Lock Washer	

E-10870

MEGA PLUS

MERITOR COACH 14-1/2" "W" SERIES BRAKE DRIVE AXLE



ITEM	QTY	EUCLID NO.	DESCRIPTION	APPLICATION & GENERAL INFORMATION
1	1	E-10826	Return Spring	For use with the following Meritor Coach 14-1/2" x 10" "W" Series Brake Shoe, Type 2: E-10809 (10") REPLACES: Dayton/Batco 08125300 Sirco BK145R Meritor KIT6003
2	4	E-10834	Anchor Pin Lock Ring	
3	2	E-10836	Anchor Pin Bushing	
4	2	E-10838	Roller	
5	2	E-10835	Anchor Pin	
6	2	NSS*	Bolt	

*Not Sold Separately

BRAKE REPAIR KITS

E-10841-AA

MEGA PLUS

MERITOR COACH 14-1/2" "W" SERIES BRAKE STEER AXLE

APPLICATION & GENERAL INFORMATION

For use with the following Meritor Coach 14-1/2" x 4" and 6" "W" Series Brake Shoes: E-10802 (4"), E-10803 (6")

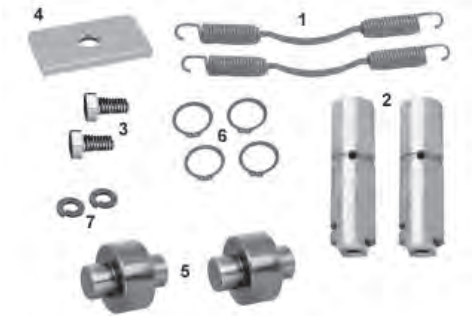

ITEM	QTY	EUCLID NO.	DESCRIPTION
1	2	E-10818	Return Spring
2	2	E-10814	Anchor Pin
3	2	NSS*	Lock Bolt
4	1	E-10817	Anchor Pin Lock
5	2	E-10812	Roller
6	4	E-801	Lock Ring
7	2	NSS*	Washer

E-10866-AA

MEGA PLUS

MERITOR COACH 14-1/2" "W" SERIES BRAKE STEER AXLE

APPLICATION & GENERAL INFORMATION

For use with the following Meritor Coach 14-1/2" x 5" "W" Series Brake Shoe:
E-10804
REPLACES:
Dayton/Batco 08125102
Sirco BK145FM

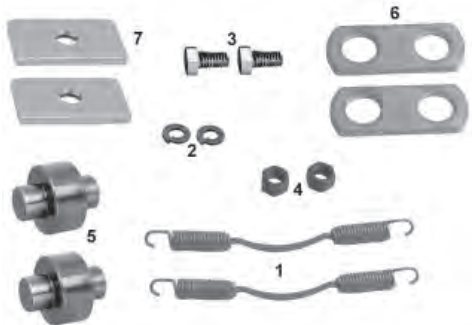

ITEM	QTY	EUCLID NO.	DESCRIPTION
1	2	E-10818	Return Spring
2	2	NSS*	Washer
3	2	NSS*	Lock Bolt
4	2	E-10821	Nut
5	2	E-10812	Roller
6	2	E-10819	Anchor Pin Link
7	2	E-10817	Anchor Pin Lock

E-11981

MEGA PLUS

EATON 15" SINGLE ANCHOR PIN FRONT BRAKE

APPLICATION & GENERAL INFORMATION

For use with the following Brake Shoe: E-11982 (4"). FMSI 4729.
REPLACES:
Dayton/Batco 08114700
Dana/Spicer 326514
Haldex CQ69007
Dana/Spicer HK97XLS
Leland K515
Meritor R615026

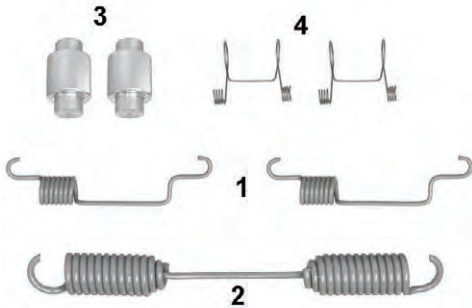

ITEM	QTY	EUCLID NO.	DESCRIPTION
1	2	E-10198	Retainer Spring
2	1	E-11980	Return Spring
3	2	E-5477	Roller
4	2	E-5478	Roller Retainer

E-1308E

STOPMATE

EATON 15" SINGLE ANCHOR PIN FRONT BRAKE

APPLICATION & GENERAL INFORMATION

Stopmate version of E-5139
REPLACES:
Dayton/Batco 08111300
Sirco EF1
Leland K263
Meritor MKT1308E



ITEM	QTY	EUCLID NO.	DESCRIPTION
1	2	E-3421A	Roller
2	1	NSS*	Retainer Spring
3	1	NSS*	Return Spring

*Not Sold Separately

BRAKE REPAIR KITS

E-5139 MEGA PLUS

EATON 15" SINGLE ANCHOR PIN FRONT BRAKE

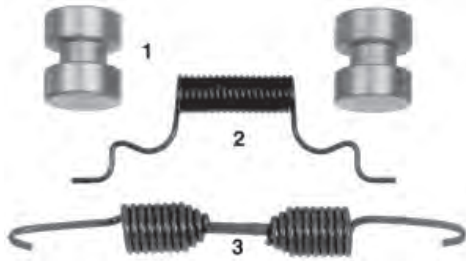

ITEM	QTY	EUCLID NO.	DESCRIPTION
1	2	E-3421A	Roller
2	1	E-5122	Retainer Spring
3	1	E-5123	Return Spring

APPLICATION & GENERAL INFORMATION

For use with the following Brake Shoe: E-5126 (4")
REPLACES:
 Dayton/Batco 081113
 Dayton/Batco 08111300
 Eaton 1008306
 Trailmobile 385139
 Eaton 5-2242
 Eaton 52242B
 Dana/Spicer 54A
 Haldex 66917
 Wagner 911030
 Haldex CQ66917
 Sirco EF1
 Dana/Spicer HK54
 Leland K263
 Meritor R507004
 Dana/Spicer TA54A

E-4702-KT STOPMATE

MERITOR 15" "Q PLUS" FRONT BRAKE



ITEM	QTY	EUCLID NO.	DESCRIPTION
1	2	E-2766S	Anchor Pin
2	1	E-9063	Return Spring
4	2	E-2177	Roller
5	2	E-1893S	Anchor Pin Bushing
6	2	E-747	Spring Retainer
7	2	E-3007A	Roller Retainer

APPLICATION & GENERAL INFORMATION

Stopmate version of E-9064.
 For use with the following Brake Shoes: E-9062 (4"), E-11453 (5"), E-11454 (6"), E-11455 (7")
REPLACES:
 Dayton/Batco 08116000
 Leland K318
 Leland K318K
 Sirco RF5

E-9064 MEGA PLUS

MERITOR 15" "Q PLUS" FRONT BRAKE



ITEM	QTY	EUCLID NO.	DESCRIPTION
1	2	E-2766S	Anchor Pin
2	2	E-1893S	Anchor Pin Bushing
3	2	E-2767	Retainer Spring
4	1	E-9063	Return Spring
5	2	E-11741	Roller
6	2	E-747	Spring Retainer
7	2	E-3007A	Roller Retainer

APPLICATION & GENERAL INFORMATION

Contains new Posi-Plus roller. For use with the following Brake Shoe: E-9062 (4") Double Web Q Plus™ Shoe
REPLACES:
 Dayton/Batco 081160
 Dayton/Batco 08116000
 Haldex CQ65642
 Leland K318
 Leland K318K
 Meritor KIT8824HD
 Meritor R508824
 Sirco RF5
 Dana/Spicer TA66A

BRAKE REPAIR KITS

E-1308Q

STOPMATE

MERITOR 15" "Q" SERIES FRONT BRAKE



ITEM	QTY	EUCLID NO.	DESCRIPTION
1	2	E-3870	Anchor Pin
2	1	E-3871	Anchor Pin Link
3	1	NSS*	Return Spring
4	1	NSS*	Retainer Spring
5	2	E-3874	Anchor Pin Washer
6	2	E-3421A	Roller
7	1	E-4961A	3/4"-16 Lock Nut
8	2	E-1120-1	Shoe Clip

APPLICATION & GENERAL INFORMATION

Stopmate version of E-3869
 REPLACES:
 Dayton/Batco 08111100
 Dayton/Batco 08111102
 Dayton/Batco 08111200
 Dana/Spicer 55A
 Dana/Spicer HK55
 Leland K282
 Leland K283
 Meritor MKT1308Q
 Sirco RF3
 Sirco RF3A
 Dana/Spicer TA55A

E-1308QMA

STOPMATE

MERITOR 15" "Q" SERIES FRONT BRAKE

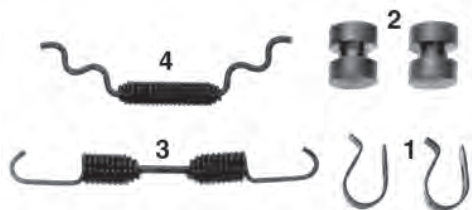

ITEM	QTY	EUCLID NO.	DESCRIPTION
1	2	E-1120-1	Shoe Clip
2	2	E-3421A	Roller
3	1	NSS*	Return Spring
4	1	NSS*	Retainer Spring

APPLICATION & GENERAL INFORMATION

Stopmate version of E-7899

E-3869

MEGA PLUS

MERITOR 15" "Q" SERIES FRONT BRAKE



ITEM	QTY	EUCLID NO.	DESCRIPTION
1	2	E-3870	Anchor Pin
2	1	E-3871	Anchor Pin Link
3	1	E-3872	Return Spring
4	1	E-3873	Retainer Spring
5	2	E-3874	Anchor Pin Washer
6	2	E-3421A	Roller
7	2	E-4961A	3/4"-16 Lock Nut
8	2	E-1120-1	Shoe Clip

APPLICATION & GENERAL INFORMATION

For use with the following Brake Shoe: E-5528 (4") Meritor Single Web 15" x 4" "Q" Series Front Brake Shoe
 REPLACES:
 Dayton/Batco 081111
 Dayton/Batco 08111100
 Dayton/Batco 1451
 Trailmobile 383869
 Dana/Spicer 55A
 Wagner 911032
 Sirco B953
 Haldex CQ69001
 Dana/Spicer HK55
 Dana/Spicer HK77
 Leland K282
 Leland K283
 Meritor KIT8029
 Leland L2932
 Meritor R508029
 Sirco RF3
 Dana/Spicer TA55A

*Not Sold Separately

BRAKE REPAIR KITS

E-7899 STOPMATE PLUS

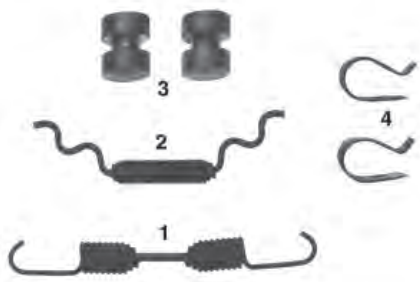

MERITOR 15" "Q" SERIES FRONT BRAKE

ITEM	QTY	EUCLID NO.	DESCRIPTION
1	1	E-3872	Return Spring
2	1	E-3873	Retainer Spring
3	2	E-3421A	Roller
4	2	E-1120-1	Shoe Clip

APPLICATION & GENERAL INFORMATION

Same as E-3869 minus Anchor Pins and Hardware. For use with the following Brake Shoe: E-5528 (4") Single Web "Q" Brake Shoe
REPLACES:
 Dayton/Batco 08111102
 Dayton/Batco 081112
 Dayton/Batco 0811200
 Trailmobile 387899
 Haldex CQ67899
 Leland K282
 Meritor R508030
 Sirco RF3A

E-4800 MEGA PLUS

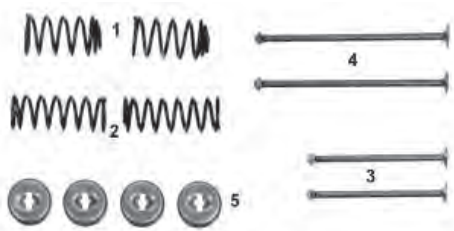

MERITOR 15" "T" SERIES FRONT BRAKE

ITEM	QTY	EUCLID NO.	DESCRIPTION
1	2	NSS*	Spring - Short
2	2	NSS*	Spring - Long
3	2	NSS*	Hold Down Pin - Short
4	2	NSS*	Hold Down Pin - Long
5	4	NSS*	Cap

APPLICATION & GENERAL INFORMATION

For use with the following brake shoes: E-3438 (3-1/2"), E-3439 (4")
REPLACES:
 Dayton/Batco 01390
 Dana/Spicer 19921
 Trailmobile 384800
 Dana/Spicer 511AK
 Sirco ARK
 Haldex CQ66759
 Leland K259
 Meritor KIT9425

E-6879 MEGA PLUS



MERITOR 15" "T" SERIES FRONT BRAKE

ITEM	QTY	EUCLID NO.	DESCRIPTION
1	2	E-3421A	Roller
2	1	E-3437	Spring
3	2	E-801	Lock Ring
4	1	E-4800	Hold Down Kit

APPLICATION & GENERAL INFORMATION

For use with the following Brake Shoes: E-3438 (3-1/2"), E-3439 (4")
REPLACES:
 Trailmobile 386879
 Dana/Spicer 511A
 Haldex CQ69003
 Leland K265
 Meritor KIT1125
 Meritor KIT9094A
 Meritor R509095
 Sirco RF2ARK
 Dana/Spicer TA51A

*Not Sold Separately

BRAKE REPAIR KITS

E-4691

MEGA PLUS

MERITOR 15" "T" SERIES FRONT BRAKE TYPES 1 and 2

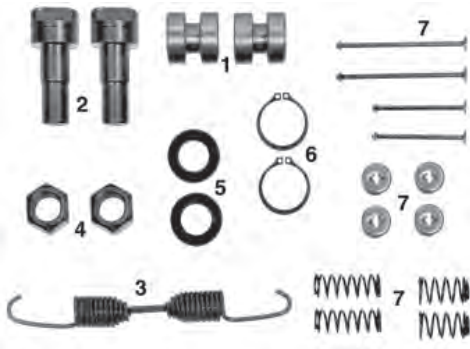

ITEM	QTY	EUCLID NO.	DESCRIPTION
1	2	E-3421A	Roller
2	2	E-3424	Brake Shoe Anchor Pin
3	1	E-3437	Spring
4	2	E-4961A	3/4"-16 Lock Nut
5	2	E-3427	Anchor Pin Washer
6	2	E-801	Lock Ring
7	1	E-4800	Hold Down Kit

APPLICATION & GENERAL INFORMATION
 For use with the following Brake Shoes: E-3438 (3-1/2"), E-3439 (4")
REPLACES:
 Dayton/Batco 081107
 Dayton/Batco 08110700
 Trailmobile 384691
 Eaton 5-3387
 Dana/Spicer 511A
 Eaton 543238
 Haldex 66919
 Wagner 911031
 Haldex CQ66919
 Dana/Spicer HK50
 Dana/Spicer HK51
 Leland K260
 Meritor KIT9094
 Meritor R509094
 Sirco RF1
 Sirco RF1ARK
 Sirco RF1ARKS
 Dana/Spicer TA511A

E-11747

STOPMATE PLUS

SPICER 15" and 16-1/2" HEAVY AXLE

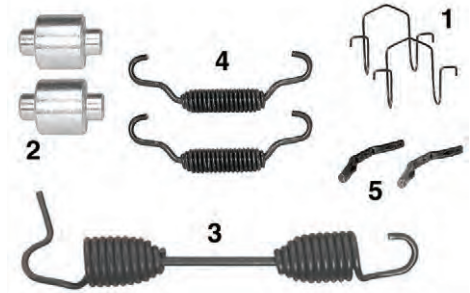

ITEM	QTY	EUCLID NO.	DESCRIPTION
1	2	E-539	Roller Retainer
2	2	E-586	Roller
3	1	NSS*	Return Spring
4	2	NSS*	Spring
5	2	E-747	Spring Retainer

APPLICATION & GENERAL INFORMATION
 For use with Spicer Heavy Axle brake shoes.
REPLACES:
 Dana/Spicer 95A
 Dana/Spicer HK95XLS

E-2740

MEGA PLUS

WAGNER 15" 3-1/2" FRONT BRAKE



ITEM	QTY	EUCLID NO.	DESCRIPTION
1	2	NSS*	Roller
2	2	NSS*	Anchor Pin
3	2	E-2723	Anchor Pin Retainer
4	8	E-2724	Guide Washer
5	4	E-2725	Spring Washer
6	4	E-2726	"C" Washer
7	1	E-979	Return Spring
8	2	E-4961A	3/4"-16 Lock Nut

APPLICATION & GENERAL INFORMATION
 For use with the following Brake Shoe: E-2728 (3-1/2")
REPLACES:
 Dayton/Batco 081102
 Dayton/Batco 08110200
 Dana/Spicer 502A
 Haldex 67313
 Haldex CQ67313
 Wagner F79791
 Dana/Spicer HK57
 Leland K130
 Leland L1669
 Meritor R507071

*Not Sold Separately

BRAKE REPAIR KITS

E-7232 STOPMATE PLUS

BENDIX 15" 4" STEER AXLE BRAKE

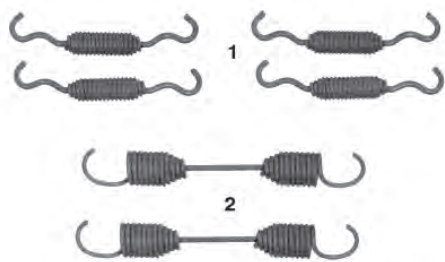

ITEM	QTY	EUCLID NO.	DESCRIPTION
1	4	NSS*	Retainer Spring
2	2	NSS*	Return Spring

APPLICATION & GENERAL INFORMATION

For use with the following shoe:
E-7230
REPLACES:
Dayton/Batco 01382
Dayton/Batco 01383
Bendix 104623
Bendix 104624
Trailmobile 387232
Sirco FF1S

E-7231 STOPMATE PLUS

BENDIX 15" 4" STEER AXLE BRAKE. "FORD CARGO"



ITEM	QTY	EUCLID NO.	DESCRIPTION
1	2	NSS*	Roller
2	2	NSS*	Pin
3	1	NSS*	Anchor Pin
4	1	NSS*	Return Spring
5	2	NSS*	Retainer Spring

APPLICATION & GENERAL INFORMATION

For use with the following shoe:
E-7230
REPLACES:
Dayton/Batco 081140
Dayton/Batco 08114000
Bendix 104627
Dana/Spicer 70A
Haldex CQ65519
Sirco FF1
Dana/Spicer HK70
Leland K297
Meritor R507080

E-11493 STOPMATE PLUS

SPICER 15" 4" STEER AXLE BRAKE

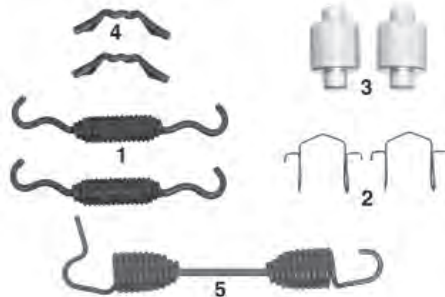

ITEM	QTY	EUCLID NO.	DESCRIPTION
1	2	E-2767	Retainer Spring
2	2	E-539	Roller Retainer
3	2	E-586	Roller
4	2	E-747	Spring Retainer
5	1	NSS*	Return Spring

APPLICATION & GENERAL INFORMATION

REPLACES:
Leland K374
Meritor R507096

E-3291 MEGA PLUS

WAGNER 15" 4" FRONT BRAKE



ITEM	QTY	EUCLID NO.	DESCRIPTION
1	2	E-3421A	Roller
2	2	NSS*	Anchor Pin
3	2	E-2723	Anchor Pin Retainer
4	8	E-2724	Guide Washer
5	4	E-2725	Spring Washer
6	4	E-2726	"C" Washer
7	1	E-2770	Return Spring Shoe Assembly
8	2	E-4961A	3/4"-16 Lock Nut

APPLICATION & GENERAL INFORMATION

For use with the following Brake Shoes: E-2729 (4"), E-4742 (4")
REPLACES:
Dayton/Batco 081099
Dayton/Batco 08109900
Dana/Spicer 531A
Haldex 66926
Haldex CQ66926
Wagner F97506
Leland K134
Meritor R507073
Sirco WF1

*Not Sold Separately

BRAKE REPAIR KITS

E-9141

MEGA PLUS

EATON 15" 6" "ES" "REDUCED ENVELOPE" FRONT AXLE BRAKE

APPLICATION & GENERAL INFORMATION

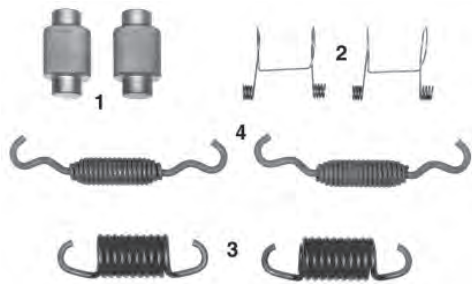

ITEM	QTY	EUCLID NO.	DESCRIPTION
1	2	E-5477	Roller
2	2	E-5478	Roller Retainer
3	2	E-9037	Return Spring
4	2	E-2767	Retainer Spring

For use with the following Brake Shoe: E-9140 (6")
 REPLACES:
 Dayton/Batco 08104300
 Eaton 823141
 Haldex CQ66947
 Sirco ES3
 Leland K356
 Meritor R507086

E-2713

MEGA PLUS

WAGNER 15" 6" and 7" DRIVE AXLE BRAKE

APPLICATION & GENERAL INFORMATION



ITEM	QTY	EUCLID NO.	DESCRIPTION
1	2	E-1337	Anchor Pin
2	4	E-801	Lock Ring
3	2	NSS*	Roller
4	2	NSS*	Roller Pin
5	1	E-980	Return Spring
6	4	E-1269	Anchor Pin Seal

For use with the following Brake Shoe: E-2712 (7")
 REPLACES:
 Dayton/Batco 081084
 Dayton/Batco 08108400
 Dana/Spicer 60A
 Haldex 67314
 Haldex CQ67314
 Wagner F33186
 Dana/Spicer HK53
 Leland K132
 Meritor R507070

E-9039

MEGA PLUS

EATON 15" 8-5/8" "ES" "REDUCED ENVELOPE" DRIVE AXLE BRAKE

APPLICATION & GENERAL INFORMATION

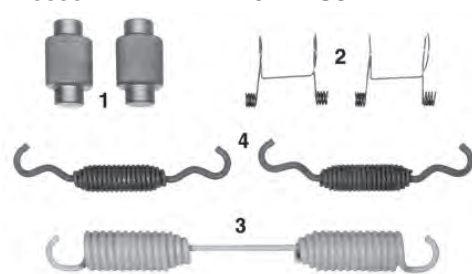

ITEM	QTY	EUCLID NO.	DESCRIPTION
1	2	E-5477	Roller
2	2	E-5478	Roller Retainer
3	1	E-9038	Return Spring
4	2	E-2767	Retainer Spring

For use with the following Brake Shoe: E-9036 (8-5/8")
 REPLACES:
 Dayton/Batco 08104330
 Eaton 815626
 Haldex CQ66948
 Sirco ES4
 Leland K358
 Meritor R507083

E-4692

MEGA PLUS

MERITOR 16-1/4" "T" SERIES FRONT BRAKE

APPLICATION & GENERAL INFORMATION



ITEM	QTY	EUCLID NO.	DESCRIPTION
1	2	E-3421A	Roller
2	2	NSS*	Anchor Pin
3	1	E-757	Return Spring
4	2	E-3426	Lock Ring
5	2	E-1106	Anchor Pin Lock Washer
6	2	E-1120-1	Shoe Clip

For use with the following Brake Shoe: E-3441 (3-1/2")
 REPLACES:
 Dayton/Batco 081108
 Dayton/Batco 08110800
 Dayton/Batco 081109
 Dayton/Batco 08110900
 Dana/Spicer 521A
 Haldex 66923
 Haldex CQ66923
 Dana/Spicer HK52
 Leland K286
 Leland K362
 Meritor KIT9424
 Dana/Spicer TA521A

*Not Sold Separately

BRAKE REPAIR KITS

E-7237

STOPMATE PLUS

BENDIX 16-1/2" TRUCK AND TRACTOR BRAKE



ITEM	QTY	EUCLID NO.	DESCRIPTION
1	2	NSS*	Roller
2	2	NSS*	Pin
3	2	NSS*	Pin
4	2	NSS*	Bushing
5	1	NSS*	Return Spring
6	2	NSS*	Spring
7	2	E-747	Spring Retainer

APPLICATION & GENERAL INFORMATION

For use with the following Brake Shoe: E-7236 (16-1/2")
 REPLACES:
 Dayton/Batco 08114002
 Dayton/Batco 081142
 Dayton/Batco 08114200
 Bendix 104628
 Trailmobile 387237
 Dana/Spicer 711A
 Haldex CQ65520
 Sirco FR1
 Dana/Spicer HK71
 Leland K299
 Meritor R507081

E-7238

STOPMATE PLUS

BENDIX 16-1/2" TRUCK AND TRACTOR BRAKE

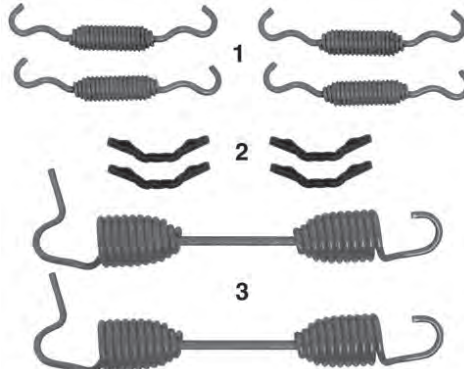

ITEM	QTY	EUCLID NO.	DESCRIPTION
1	4	NSS*	Spring
2	4	E-747	Spring Retainer
3	2	NSS*	Return Spring

APPLICATION & GENERAL INFORMATION

For use with the following Brake Shoe: E-7236 (16-1/2")
 REPLACES:
 Dayton/Batco 01384
 Dayton/Batco 01385
 Bendix 104624
 Sirco FR1S
 Meritor R507082

E-11318

STOPMATE PLUS

EATON 16-1/2" "ES" "EXTENDED SERVICE" BRAKE

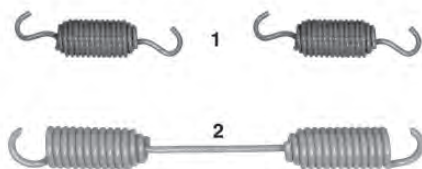

ITEM	QTY	EUCLID NO.	DESCRIPTION
1	2	E-1418	Retainer Spring
2	1	E-10197	Return Spring

APPLICATION & GENERAL INFORMATION

For use with the following Brake Shoe: E-5480 (7"). Can only be used with Eaton "ES" Camshafts.
 REPLACES:
 Sirco K3

E-4709ES-N

STOPMATE

EATON 16-1/2" "ES" "EXTENDED SERVICE" BRAKE

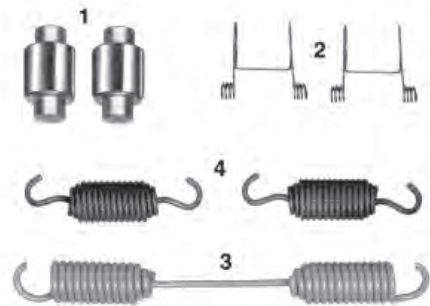

ITEM	QTY	EUCLID NO.	DESCRIPTION
1	2	NSS*	Roller
2	2	NSS*	Roller Retainer
3	1	NSS*	Return Spring
4	2	NSS*	Retainer Spring

APPLICATION & GENERAL INFORMATION

Stopmate version of E-5481A and E-11318. For use with the following Brake Shoe: E-5480 (7"). Can only be used with Eaton "ES" Camshafts. Also available bagged as part number E-4709ES-N-B.
 REPLACES:
 Dayton/Batco 08114800
 Sirco ES1
 Leland K295
 Sirco K3

*Not Sold Separately

BRAKE REPAIR KITS

E-5481A

MEGA PLUS

EATON 16-1/2" "ES" "EXTENDED SERVICE" BRAKE

APPLICATION & GENERAL INFORMATION

ITEM	QTY	EUCLID NO.	DESCRIPTION
1	2	E-1418	Retainer Spring
2	1	E-10197	Return Spring
3	2	E-5477	Roller
4	2	E-5478	Roller Retainer
5	1	E-3887	Anti-Seize Compound

For use with the following Brake Shoe: E-5480 (7"). Can only be used with Eaton "ES" Camshafts.
REPLACES:
 Dayton/Batco 081148
 Dayton/Batco 08114800
 Trailmobile 385481
 Eaton 5808330
 Eaton 5808330B
 Dana/Spicer 631A
 Dana/Spicer 632A
 Dana/Spicer 63A
 Haldex CQ65481
 Sirco ES1
 Dana/Spicer HK62
 Dana/Spicer HK63
 Dana/Spicer HK63XLS
 Leland K295
 Meritor R507057
 Meritor R507057BK
 Meritor R507057BULK
 Dana/Spicer TA63A

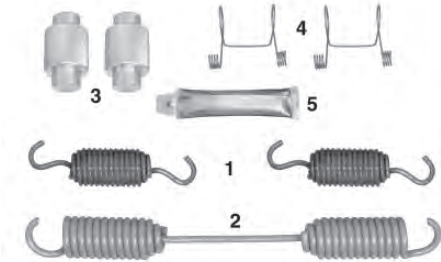

E-9048

MEGA PLUS

EATON 16-1/2" "ES" "SEVERE SERVICE" BRAKE WITH CAST SHOES

APPLICATION & GENERAL INFORMATION

ITEM	QTY	EUCLID NO.	DESCRIPTION
1	2	E-9041	Anchor Pin
2	2	E-9042	Set Screw
3	4	E-1113	Washer
4	4	E-801	Lock Ring
5	4	E-9047	Brake Shoe Bushing
6	2	E-919	Anchor Pin Bushing
7	2	E-9043	Roller
8	2	E-9044	Roller Pin
9	2	E-9045	Lock Pin Roll
10	1	E-9046	Return Spring

For use with the following Brake Shoe: E-9040 (7")
REPLACES:
 Dayton/Batco 081157
 Dayton/Batco 08115700
 Eaton 810213
 Dana/Spicer HK72
 Leland K307
 Meritor R507084



E-9052

MEGA PLUS

EATON 16-1/2" "ES" "SEVERE SERVICE" BRAKE WITH FABRICATED SHOES

APPLICATION & GENERAL INFORMATION

ITEM	QTY	EUCLID NO.	DESCRIPTION
1	2	NSS*	Anchor Pin
2	2	E-9042	Set Screw
3	4	E-1113	Washer
4	4	E-801	Lock Ring
5	2	E-919	Anchor Pin Bushing
6	2	E-11741	Roller
7	2	E-5478	Roller Retainer
8	2	E-747	Spring Retainer
9	1	E-8907	Return Spring

Contains new Posi-Plus roller.
REPLACES:
 Dayton/Batco 081156
 Dayton/Batco 08115600
 Eaton 812118
 Leland E9052
 Meritor R507085



*Not Sold Separately

BRAKE REPAIR KITS

E-10244

MEGA PLUS

EATON 16-1/2" "ES-II" "EXTENDED SERVICE" BRAKE

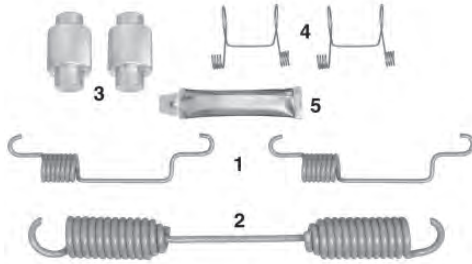

ITEM	QTY	EUCLID NO.	DESCRIPTION
1	2	E-10198	Retainer Spring
2	1	E-10197	Return Spring
3	2	E-5477	Roller
4	2	E-5478	Roller Retainer
5	1	E-3887	Anti-Seize Compound

APPLICATION & GENERAL INFORMATION

For use with New "ES-II", No-Tab Shoe with Retainer Spring holes in web. **IMPORTANT NOTE:** Install Retainer Springs with coil end up. Can only be used with Eaton "ES" Camshafts.
 REPLACES:
 Eaton 314147
 Dana/Spicer 631A
 Haldex CQ65477
 Dana/Spicer HK61
 Dana/Spicer HK61SD
 Dana/Spicer HK61XLS
 Leland K375
 Meritor R507064

E-10244S

STOPMATE PLUS

EATON 16-1/2" "ES-II" "EXTENDED SERVICE" BRAKE

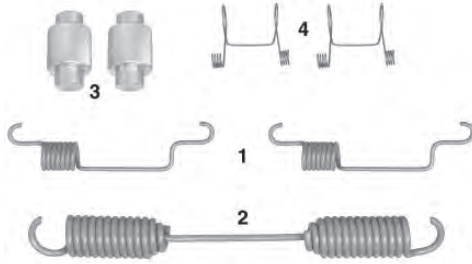

ITEM	QTY	EUCLID NO.	DESCRIPTION
1	2	E-10198	Retainer Spring
2	1	E-10197	Return Spring
3	2	E-5477	Roller
4	2	E-5478	Roller Retainer

APPLICATION & GENERAL INFORMATION

For use with New "ES-II", No-Tab Shoe with Retainer Spring holes in web. **IMPORTANT NOTE:** Install Retainer Springs with coil end up. Can only be used with Eaton "ES" Camshafts.
 REPLACES:
 Eaton 314147
 Dana/Spicer 631A
 Sirco ES2
 Meritor R507064

E-11319

STOPMATE PLUS

EATON 16-1/2" "ES-II" "EXTENDED SERVICE" BRAKE

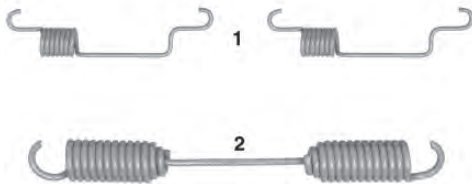

ITEM	QTY	EUCLID NO.	DESCRIPTION
1	2	E-10198	Retainer Spring
2	1	E-10197	Return Spring

APPLICATION & GENERAL INFORMATION

For use with New "ES-II", No-Tab Shoe with Retainer Spring holes in web. **IMPORTANT NOTE:** Install Retainer Springs with coil end up. Can only be used with Eaton "ES" Camshafts.
 REPLACES:
 Sirco K4

E-4709ES2-N

STOPMATE

EATON 16-1/2" "ES-II" "EXTENDED SERVICE" BRAKE

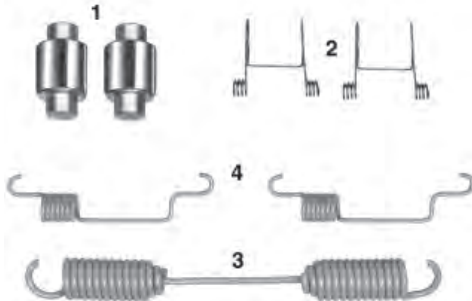

ITEM	QTY	EUCLID NO.	DESCRIPTION
1	2	NSS*	Roller
2	2	NSS*	Roller Retainer
3	1	NSS*	Return Spring
4	2	NSS*	Retainer Spring

APPLICATION & GENERAL INFORMATION

Stopmate version of E-10244. For use with the following Brake Shoes: E-10272 (7"), E-10273 (8-5/8") Can only be used with Eaton "ES" Camshafts. Also available bagged as part number E-4708ES2-B.
 REPLACES:
 Haldex CQ65477
 Sirco ES2
 Leland K375
 Sirco K4

*Not Sold Separately

BRAKE REPAIR KITS

E-10760

MEGA PLUS

EATON 16-1/2" "ES-II" "EXTENDED" SERVICE FRONT AXLE BRAKE

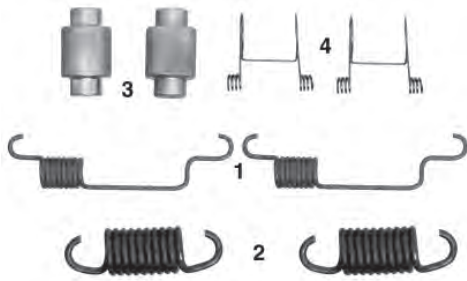

ITEM	QTY	EUCLID NO.	DESCRIPTION
1	2	E-10198	Retainer Spring
2	2	E-9037	Return Spring
3	2	E-5477	Roller
4	2	E-5478	Roller Retainer

APPLICATION & GENERAL INFORMATION

For use with "ES-II" 16-1/2" front axle shoes: E-10270 (5"), E-10271 (6"). Can only be used with Eaton "ES" Camshafts. Must be used with E-10761 Horse Collar.

REPLACES:

Dayton/Batco 08114920
 Eaton 314146
 Haldex CQ65446
 Sirco EF2
 Dana/Spicer HK62XLS
 Leland K376
 Meritor R507094

E-1887AHD

MEGA PLUS

EATON 16-1/2" SINGLE ANCHOR PIN BRAKE

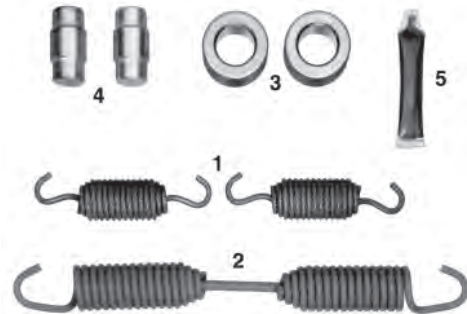

ITEM	QTY	EUCLID NO.	DESCRIPTION
1	2	E-1418	Retainer Spring
2	1	E-1428A	Return Spring
3	2	E-2217A	Roller
4	2	E-596A	Roller Pin
5	1	E-3887	Anti-Seize Compound

APPLICATION & GENERAL INFORMATION

Contains Special Alloy Steel Knurled Rollers. For use with the following Brake Shoes: E-1777 (6"), E-1778 (7")

REPLACES:

Dayton/Batco 081122
 Eaton 1001238
 Trailmobile 381887AHD
 Wagner 911011
 Sirco EK1HD
 Dana/Spicer HK24XLSLM
 Hercules KIT#2
 Meritor R507002

BRAKE REPAIR KITS

E-1887ASHD

STOPMATE PLUS

EATON 16-1/2" SINGLE ANCHOR PIN BRAKE

ITEM	QTY	EUCLID NO.	DESCRIPTION
1	2	E-1418	Retainer Spring
2	1	E-1428S	Return Spring
3	2	E-2217S	Roller
4	2	E-596A	Roller Pin

APPLICATION & GENERAL INFORMATION

Contains Special Alloy Steel Knurled Rollers. For use with the following Brake Shoes: E-1777 (6"), E-1778 (7")
 REPLACES:
 Dayton/Batco 081042
 Dayton/Batco 08104200
 Dayton/Batco 081709
 Eaton 1001238
 Dana/Spicer 241A
 Dana/Spicer 241ABULK
 Dana/Spicer 24A
 Dana/Spicer 24ABULK
 Trailmobile 381887ASHD
 Sirco 4311EHD
 Eaton 52243
 Eaton 52243B
 Haldex 67319
 Trailmobile 7007237
 Trailmobile 7007261
 Trailmobile 70074
 Wagner 911010
 Haldex CQ67319
 Sirco EK1HD
 Sirco EK1HDS
 Sirco EKINT
 Leland K119
 Leland K42
 Hercules KIT#2
 Fruehauf MBCBK0030
 Meritor R507002
 Meritor R507002BK
 Meritor R507002BULK
 Dana/Spicer TA241A
 Haldex WKH1J

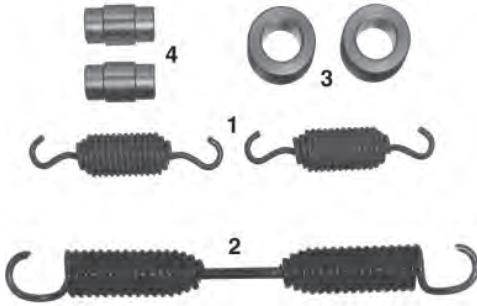

E-2820

MEGA PLUS

EATON 16-1/2" SINGLE ANCHOR PIN BRAKE

ITEM	QTY	EUCLID NO.	DESCRIPTION
1	2	E-1418	Retainer Spring
2	1	E-2785	Return Spring
3	2	E-2217A	Roller
4	2	E-596A	Roller Pin

APPLICATION & GENERAL INFORMATION

Alternate for E-1887AHD and E-1887ASHD Kits. Return Spring has longer center bar for additional spindle clearance. For use with the following Brake Shoes: E-1777 (6"), E-1778 (7")
 REPLACES:
 Dayton/Batco 08104230
 Dayton/Batco 081053
 Dana/Spicer 25A
 Eaton 5-3690
 Eaton 653907
 Wagner 911012
 Dana/Spicer HK24XLSHM
 Leland K110
 Meritor R507003
 Dana/Spicer TA251A

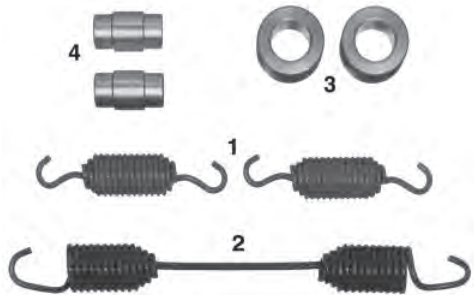

BRAKE REPAIR KITS

E-4311EHD-N

STOPMATE

EATON 16-1/2" SINGLE ANCHOR PIN BRAKE

APPLICATION & GENERAL INFORMATION

Stopmate version of E-1887 series kits. Also available bagged as part number E-4311EHD-N-B.
 REPLACES:
 Dayton/Batco 081042
 Dayton/Batco 08104200
 Dayton/Batco 081122
 Dayton/Batco 081709
 Sirco 4311EHD
 Haldex 67319
 Haldex CQ67319
 Sirco EK1HD
 Sirco EKINT
 Leland K119
 Leland K42
 Hercules KIT#2

ITEM	QTY	EUCLID NO.	DESCRIPTION
1	2	NSS*	Retainer Spring
2	1	NSS*	Return Spring
3	2	NSS*	Roller
4	2	NSS*	Roller Pin

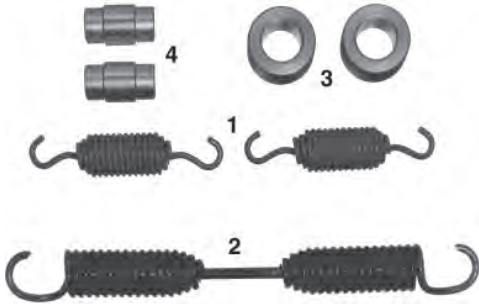

E-3801

MEGA PLUS

EATON 16-1/2" SINGLE ANCHOR PIN BRAKE - FORD SPECIAL APPLICATION

APPLICATION & GENERAL INFORMATION

For use with the following High-Mount Brake Shoes: E-2474 (5"), E-9509 (6"), E-2819 (7"). Brake Shoe has offset Spring Retainer Pin. Used in some Ford applications.
 REPLACES:
 Dayton/Batco 081103
 Dana/Spicer 241AF
 Haldex CQ69004
 Sirco EK3
 Dana/Spicer HK24XLSHM
 Leland K316
 Meritor R507077

ITEM	QTY	EUCLID NO.	DESCRIPTION
1	2	E-1418	Retainer Spring
2	1	E-2475	Return Spring
3	2	E-2217A	Roller
4	2	E-596A	Roller Pin

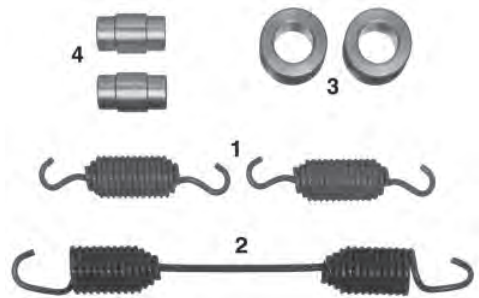

E-8923

MEGA PLUS

EATON TOP SPEC 16-1/2" "ES" RETROFIT FOR FRUEHAUF

APPLICATION & GENERAL INFORMATION

Contains new Posi-Plus roller. For use with the following Brake Shoe: E-8922 (7")
 REPLACES:
 Dayton/Batco 081158
 Dayton/Batco 08115800
 Eaton 5-3321
 Eaton 519132
 Haldex CQ65478
 Sirco EX1
 Leland K309
 Leland K309K
 Leland K330
 Meritor R507061
 Dana/Spicer TA65A

ITEM	QTY	EUCLID NO.	DESCRIPTION
1	2	E-3711	Anchor Pin
2	2	E-8938	Anchor Pin Bushing
3	2	E-2767	Retainer Spring
4	1	E-8907	Return Spring
5	2	E-11741	Roller
6	2	E-747	Spring Retainer
7	2	E-5478	Roller Retainer
8	1	E-1559	Cotter Pin
9	1	E-3887	Anti-Seize Compound



*Not Sold Separately

BRAKE REPAIR KITS

E-8925

MEGA PLUS

EATON TOP SPEC 16-1/2" "ES" RETROFIT FOR MERITOR



ITEM	QTY	EUCLID NO.	DESCRIPTION
1	2	E-2766S	Anchor Pin
2	2	E-8938	Anchor Pin Bushing
3	2	E-2767	Retainer Spring
4	1	E-8907	Return Spring
5	2	E-11741	Roller
6	2	E-747	Spring Retainer
7	2	E-5478	Roller Retainer
8	1	E-3887	Anti-Seize Compound

APPLICATION & GENERAL INFORMATION

Contains new Posi-Plus roller. For use with the following Brake Shoe: E-8924 (7")
 REPLACES:
 Dayton/Batco 081154
 Dayton/Batco 08115400
 Eaton 5-3319
 Eaton 518401
 Haldex CQ65479
 Sirco EQ1
 Leland K322
 Meritor R507062
 Dana/Spicer TA67A

E-2121

MEGA PLUS

FRUEHAUF "PRO-PAR" 16-1/2"



ITEM	QTY	EUCLID NO.	DESCRIPTION
1	2	E-609	Anchor Pin
2	2	NSS*	Roll Pin
3	2	E-920	Anchor Pin Bushing
4	2	E-3227	Roller Retainer
5	2	E-11741	Roller
6	1	E-545A	Return Spring
7	2	E-747	Spring Retainer

APPLICATION & GENERAL INFORMATION

For Old Style Spiders drilled for Roll Pin. For New Style Spiders not drilled for Roll Pin, use Euclid Kits E-1816HD, E-1816S or E-1816SHD. Contains new Posi-Plus roller. For use with the following Brake Shoe: E-2685 (7")
 REPLACES:
 Dayton/Batco 081006
 Dayton/Batco 08100600
 Eaton 124305
 Dana/Spicer 171A
 Eaton 5-2240
 Eaton 52240B
 Haldex 67316
 Trailmobile 7007203
 Wagner 911002
 Fruehauf ACC001996902
 Haldex CQ67316
 Sirco FK1
 Dana/Spicer HK17XLS
 Leland K266
 Leland K43
 Meritor R507011
 Dana/Spicer TA18A

*Not Sold Separately

BRAKE REPAIR KITS

E-2121HD

MEGA PLUS

FRUEHAUF "PRO-PAR" 16-1/2"

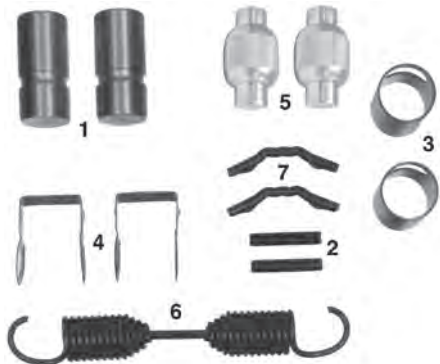

ITEM	QTY	EUCLID NO.	DESCRIPTION
1	2	E-609	Anchor Pin
2	2	NSS*	Roll Pin
3	2	E-920	Anchor Pin Bushing
4	2	E-3227	Roller Retainer
5	2	E-11741	Roller
6	1	E-1880B	Return Spring
7	2	E-747	Spring Retainer

APPLICATION & GENERAL INFORMATION

For Old Style Spiders drilled for Roll Pin. For New Style Spiders not drilled for Roll Pin, use Euclid Kits E-1816HD, E-1816S or E-1816SHD. Contains new Posi-Plus roller. For use with the following Brake Shoe: E-2685 (7"). Same as E-2121 except has Heavy Duty Return Spring.

REPLACES:

- Dayton/Batco 08100660
- Dayton/Batco 081124
- Dayton/Batco 081134
- Dana/Spicer 18A
- Haldex CQ67399
- Sirco FK1HD
- Dana/Spicer HK17XLS
- Fruehauf MBCBK0013
- Meritor R507012

E-4880S

STOPMATE PLUS

FRUEHAUF "PRO-PAR" 16-1/2" EARLY MODEL "XEM" BRAKE



ITEM	QTY	EUCLID NO.	DESCRIPTION
1	1	E-3228	Return Spring
2	2	NSS*	Roll Pin
3	2	E-747	Spring Retainer
4	2	E-920S	Anchor Pin Bushing
5	1	E-1559	Cotter Pin
6	2	E-11741	Roller
7	2	E-2773	Anchor Pin
8	2	E-3007A	Roller Retainer
9	2	E-2767	Retainer Spring

APPLICATION & GENERAL INFORMATION

Contains new Posi-Plus roller. For use with the following Brake Shoe: E-5487 (7")

REPLACES:

- Dayton/Batco 081090
- Dayton/Batco 08109000
- Eaton 126496
- Dana/Spicer 311A
- Trailmobile 384880S
- Eaton 5-2246
- Eaton 52246B
- Haldex 66865
- Trailmobile 70017307
- Trailmobile 7007224
- Wagner 911017
- Fruehauf ACC001996903
- Haldex CQ67401
- Dana/Spicer HK31XLS
- Leland K118
- Leland K127
- Leland K76
- Meritor R507006
- Sirco XK1

*Not Sold Separately

BRAKE REPAIR KITS

E-4880SHD

STOPMATE PLUS

FRUEHAUF "PRO-PAR" 16-1/2" EARLY MODEL "XEM" BRAKE



ITEM	QTY	EUCLID NO.	DESCRIPTION
1	1	E-3490S	Return Spring
2	2	NSS*	Roll Pin
3	2	E-747	Spring Retainer
4	2	E-920S	Anchor Pin Bushing
5	1	E-1559	Cotter Pin
6	2	E-11741	Roller
7	2	E-2773	Anchor Pin
8	2	E-3007A	Roller Retainer
9	2	E-2767	Retainer Spring

APPLICATION & GENERAL INFORMATION

Contains new Posi-Plus roller. For use with the following Brake Shoe: E-5487 (7"). Same as E-4880S except has Heavy Duty Return Spring.

REPLACES:

- Dayton/Batco 08109030
- Dayton/Batco 081127
- Dayton/Batco 081135
- Dayton/Batco 081711
- Dana/Spicer 311A
- Trailmobile 384880SHD
- Haldex 66875
- Trailmobile 7007202
- Wagner 911018
- Fruehauf ACC001996903
- Haldex CQ66875
- Haldex CQ68875
- Fruehauf MBCBK0011
- Fruehauf MBCBK0012
- Meritor R507007
- Sirco XK1HD

E-3710HD

MEGA PLUS

FRUEHAUF "PRO-PAR" 16-1/2" LATE MODEL "XEM" BRAKE



ITEM	QTY	EUCLID NO.	DESCRIPTION
1	2	E-3711	Anchor Pin
2	2	E-8938	Anchor Pin Bushing
3	2	E-2767	Retainer Spring
4	1	E-3490B	100 lb Return Spring
5	2	E-11741	Roller
6	2	E-747	Spring Retainer
7	2	E-3227	Roller Retainer
8	1	E-1559	Cotter Pin
9	1	E-3887	Anti-Seize Compound

APPLICATION & GENERAL INFORMATION

Contains new Posi-Plus roller. For use with the following Brake Shoes: E-3920 (7"), E-3713 (8-5/8" LH), E-3714 (8-5/8" RH)

REPLACES:

- Dayton/Batco 08109130
- Dayton/Batco 08109134
- Dayton/Batco 08109138
- Dayton/Batco 08109165
- Dayton/Batco 081130
- Dayton/Batco 081136
- Dana/Spicer 34A
- Trailmobile 383710
- Trailmobile 383710HD
- Fruehauf ACC001996923
- Haldex CQ66914
- Dana/Spicer HK34SD
- Dana/Spicer HK34XLS
- Leland K354
- Hercules KIT#3
- Meritor R507008
- Meritor R507010
- Sirco XK3MPHD
- Sirco XKINT

*Not Sold Separately

BRAKE REPAIR KITS

E-3710S

STOPMATE PLUS

FRUEHAUF "PRO-PAR" 16-1/2" LATE MODEL "XEM" BRAKE

ITEM	QTY	EUCLID NO.	DESCRIPTION
1	2	E-3711S	Anchor Pin
2	2	E-1893S	Anchor Pin Bushing
3	2	E-2767	Retainer Spring
4	1	E-3228	Return Spring
5	2	E-11741	Roller
6	2	E-747	Spring Retainer
7	2	E-3007A	Roller Retainer
8	1	E-1559	Cotter Pin

APPLICATION & GENERAL INFORMATION

Contains new Posi-Plus roller.
 For use with the following Brake Shoes:
 E-3920 (7"), E-3713 (8-5/8" LH),
 E-3714 (8-5/8" RH)
 REPLACES:
 Dayton/Batco 081091
 Dayton/Batco 08109100
 Dayton/Batco 08109105
 Eaton 126861
 Dana/Spicer 341A
 Dana/Spicer 341ABULK
 Trailmobile 383710S
 Eaton 5-2247
 Eaton 52247B
 Haldex 66913
 Trailmobile 7007238
 Trailmobile 7007259
 Wagner 911015
 Fruehauf ACC001996923
 Haldex CQ66913
 Dana/Spicer HK34XLS
 Leland K135
 Leland K280
 Leland K280A
 Leland K309K
 Leland K315
 Leland K328
 Leland K330
 Meritor R507008
 Meritor R507008BK
 Meritor R507008BULK
 Sirco XK3



BRAKE REPAIR KITS

E-3710SHD

STOPMATE PLUS

FRUEHAUF "PRO-PAR" 16-1/2" LATE MODEL "XEM" BRAKE



ITEM	QTY	EUCLID NO.	DESCRIPTION
1	2	E-3711S	Anchor Pin
2	2	E-1893S	Anchor Pin Bushing
3	2	E-2767	Retainer Spring
4	1	E-3490S	Return Spring
5	2	E-11741	Roller
6	2	E-747	Spring Retainer
7	2	E-3007A	Roller Retainer
8	1	E-1559	Cotter Pin

APPLICATION & GENERAL INFORMATION

Contains new Posi-Plus roller.
 For use with the following Brake Shoes:
 E-3920 (7"), E-3713 (8-5/8" LH), E-3714 (8-5/8" RH). Same as E-3710S except has Heavy Duty Return Spring.
REPLACES:
 Dayton/Batco 08109135
 Dayton/Batco 08109138
 Dayton/Batco 08109165
 Dayton/Batco 081136
 Dayton/Batco 081713
 Dana/Spicer 341A, 34A, 34ABULK
 Trailmobile 383710SHD
 Sirco 4515XHD
 Haldex 66914
 Trailmobile 7007196
 Trailmobile 7007260
 Wagner 911016
 Haldex CQ66914
 Leland K136
 Fruehauf MBCBK0010
 Meritor R507010
 Meritor R507010BK
 Meritor R507010BULK
 Dana/Spicer TA341A
 Haldex WKH1EZF
 Haldex WKH1EZFX
 Sirco XK3HD

E-4515X

STOPMATE

FRUEHAUF "PROPAR" 16-1/2" LATE MODEL "XEM" BRAKE

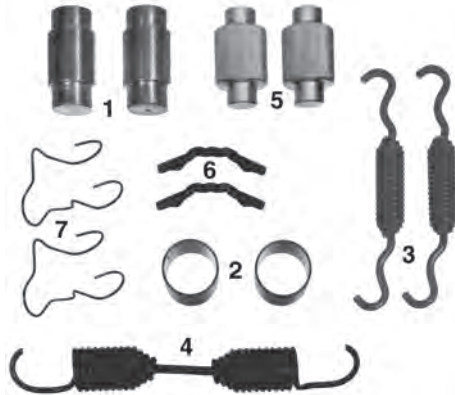

ITEM	QTY	EUCLID NO.	DESCRIPTION
1	2	E-3711	Anchor Pin
2	2	E-1893S	Anchor Pin Bushing
4	1	E-3228	Return Spring
5	2	E-2177	Roller
6	2	E-747	Spring Retainer
7	2	E-3007A	Roller Retainer

APPLICATION & GENERAL INFORMATION

Stopmate version of E-3710S
REPLACES:
 Dayton/Batco 08109100
 Dayton/Batco 08109105
 Dana/Spicer 341A
 Dana/Spicer 341ABULK
 Dana/Spicer HK34XLS
 Leland K135, K280, K280A, K309K, K315, K328, K330
 Meritor MKT4515X
 Sirco XK3, 4515X

BRAKE REPAIR KITS

KIT-5

MEGA PLUS

FRUEHAUF (MODIFIED NO. 5) 16-1/2" EARLY MODEL BRAKE

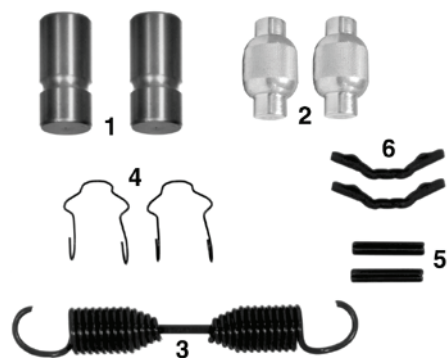

ITEM	QTY	EUCLID NO.	DESCRIPTION
1	2	E-609	Anchor Pin
2	2	E-11741	Roller
3	1	E-545A	Return Spring
4	2	E-3007A	Roller Retainer
5	2	NSS*	Roll Pin
6	2	E-747	Spring Retainer

APPLICATION & GENERAL INFORMATION

Contains new Posi-Plus roller. For use with the following Brake Shoe: E-2685 (7")
REPLACES:
 Dayton/Batco 081005
 Dayton/Batco 08100601
 Dayton/Batco 081037
 Eaton 124670, 5-2241
 Haldex 67434
 Trailmobile 7007158
 Sirco FK2, FK2HD
 Leland K58
 Fruehauf MBCBK0014
 Meritor R507013

E-4515XHD

STOPMATE

FRUEHAUF "PROPAR" 16-1/2" LATE MODEL "XEM" BRAKE



ITEM	QTY	EUCLID NO.	DESCRIPTION
1	2	E-3711S	Anchor Pin
2	2	E-1893S	Anchor Pin Bushing
3	2	NSS*	Retainer Spring
4	1	NSS*	Return Spring
5	2	E-2177	Roller
6	2	E-747	Spring Retainer
7	2	E-3007A	Roller Retainer

APPLICATION & GENERAL INFORMATION

Stopmate version of E-3710SHD
REPLACES:
 Dayton/Batco 08109130
 Dayton/Batco 08109134
 Dayton/Batco 08109135
 Dayton/Batco 08109165
 Dayton/Batco 081136
 Dayton/Batco 081713
 Dana/Spicer 34A
 Dana/Spicer 34ABULK
 Sirco 4515XHD
 Leland K136
 Leland K354
 Hercules KIT#3
 Meritor MKT4515XHD
 Dana/Spicer TA341A
 Sirco XK3HD
 Sirco XK3MPHD
 Sirco XKINT

*Not Sold Separately

BRAKE REPAIR KITS

E-9142 MEGA PLUS

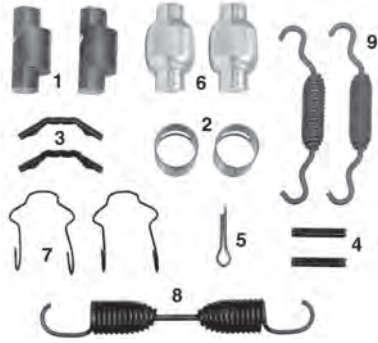

FRUEHAUF RETROFIT MERITOR "Q" BRAKE W/ECCENTRIC ANCHOR PIN 16-1/2"

ITEM	QTY	EUCLID NO.	DESCRIPTION	APPLICATION & GENERAL INFORMATION
1	2	E-9061	Anchor Pin	Special offset Anchor Pin allows use of Meritor "Q" Brake Shoes on Fruehauf "Pro-Par" Axles. Contains new Posi-Plus roller. For use with the following Brake Shoe: E-2778 (7") REPLACES: Dayton/Batco 081137 Dayton/Batco 08113700 Leland K326 Meritor R507087
2	2	E-920	Anchor Pin Bushing	
3	2	E-747	Spring Retainer	
4	2	NSS*	Roll Pin	
5	1	E-1559	Cotter Pin	
6	2	E-11741	Roller	
7	2	E-3007A	Roller Retainer	
8	1	E-2768	Return Spring	
9	2	E-2767	Retainer Spring	

E-4515Q-N STOPMATE

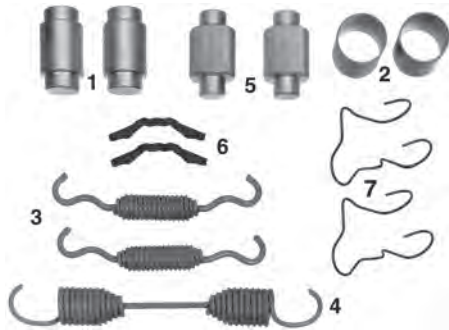

HENDRICKSON, MERITOR and SPICER (DANA) 16-1/2"

ITEM	QTY	EUCLID NO.	DESCRIPTION	APPLICATION & GENERAL INFORMATION
1	2	NSS*	Anchor Pin	For Meritor "Q" and Q Plus™, Spicer (Dana) "Fast Change" and "XLII", and Hendrickson Intraax® Brakes. Stopmate version of E-2769S. Also available bagged as part number E-4515Q-N-N-B. REPLACES: Dayton/Batco 08108801 Dayton/Batco 08108805 Dayton/Batco 081702 Eaton 126131 Dana/Spicer 281A Dana/Spicer 281ABULK Dana/Spicer 281AR Dana/Spicer 281ARBULK Sirco 4515Q Eaton 52245B Dana/Spicer HK29 Leland K117 Leland K306 Leland K70 Sirco QK1
2	2	NSS*	Anchor Pin Bushing	
3	2	NSS*	Retainer Spring	
4	1	NSS*	Return Spring	
5	2	NSS*	Roller	
6	2	NSS*	Spring Retainer	
7	2	NSS*	Roller Retainer	

*Not Sold Separately

BRAKE REPAIR KITS

E-4515QHD-N

STOPMATE

HENDRICKSON, MERITOR and SPICER (DANA) 16-1/2"

ITEM	QTY	EUCLID NO.	DESCRIPTION
1	2	NSS*	Anchor Pin
2	2	NSS*	Anchor Pin Bushing
3	2	NSS*	Retainer Spring
4	1	NSS*	Return Spring
5	2	NSS*	Roller
6	2	NSS*	Spring Retainer
7	2	NSS*	Roller Retainer

APPLICATION & GENERAL INFORMATION

For Meritor "Q" and Q Plus™, Spicer (Dana) "Fast Change" and "XLII", and Hendrickson Intraax® Brakes. Stopmate version of E-2769SHD. Also available bagged as part number E-4515Q-N-NHD-N-B.

REPLACES:

Dayton/Batco 08108800
 Dayton/Batco 08108830
 Dayton/Batco 08108831
 Dayton/Batco 08108865
 Dayton/Batco 08108875
 Dayton/Batco 081126
 Dayton/Batco 081703
 Dana/Spicer 28A
 Dana/Spicer 291A
 Dana/Spicer 291ABULK
 Dana/Spicer 291AR
 Dana/Spicer 29A
 Leland 4515AQHD
 Sirco 4515QHD
 Dana/Spicer HK29
 Dana/Spicer HK29XLS
 Leland K128
 Leland K128K
 Leland K329
 Leland K332
 Leland K339
 Hercules KIT#1
 Sirco QK1HD
 Sirco QK1MPHD
 Sirco QKINT
 Dana/Spicer TA291A



E-4515QMB-N

STOPMATE

HENDRICKSON, MERITOR and SPICER (DANA) 16-1/2"

ITEM	QTY	EUCLID NO.	DESCRIPTION
1	2	NSS*	Anchor Pin
2	2	NSS*	Retainer Spring
3	1	NSS*	Return Spring
4	2	NSS*	Roller
5	2	NSS*	Spring Retainer
6	2	NSS*	Roller Retainer

APPLICATION & GENERAL INFORMATION

For Meritor "Q" and Q Plus™, Spicer (Dana) "Fast Change" and "XLII", and Hendrickson Intraax® Brakes. Stopmate version of E-6999S. Also available bagged as part number E-4515Q-N-NMB-N-B.



*Not Sold Separately

BRAKE REPAIR KITS

E-4515QMBHD-N STOPMATE

HENDRICKSON, MERITOR and SPICER (DANA) 16-1/2"

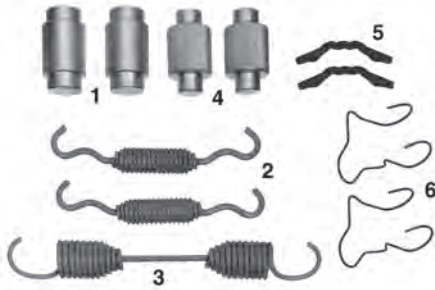

ITEM	QTY	EUCLID NO.	DESCRIPTION
1	2	NSS*	Anchor Pin
2	2	NSS*	Retainer Spring
3	1	NSS*	Return Spring
4	2	NSS*	Roller
5	2	NSS*	Spring Retainer
6	2	NSS*	Roller Retainer

APPLICATION & GENERAL INFORMATION
 For Meritor "Q" and Q Plus™, Spicer (Dana) "Fast Change" and "XLII", and Hendrickson Intraax® Brakes. Stopmate version of E-6999SHD. Also available bagged as part number E-4515Q-N-NMB-NHD-N-B.

E-2769HD

MEGA PLUS

HENDRICKSON, MERITOR and SPICER (DANA) 16-1/2" BRAKES



ITEM	QTY	EUCLID NO.	DESCRIPTION
1	2	E-2766S	Anchor Pin
2	2	E-8938	Anchor Pin Bushing
3	2	E-2767	Retainer Spring
4	1	E-3490B	100 lb Return Spring
5	2	E-11741	Roller
6	2	E-747	Spring Retainer
7	2	E-3007A	Roller Retainer
8	1	E-3887	Anti-Seize Compound

APPLICATION & GENERAL INFORMATION
 For Meritor "Q" and Q Plus™, Spicer (Dana) "Fast Change" and "XLII", and Hendrickson Intraax® brakes. Contains new Posi-Plus roller. For use with the following Brake Shoes: E-3303 (5"), E-3304 (6"), E-2778 (7"), E-6075 (7"), E-3522 (8-5/8"), E-3417 (10"). Note: To insure quick brake release and full lining life, Q Plus™ brakes use only heavy-duty return springs.

- REPLACES:**
- Dayton/Batco 081088
 - Dayton/Batco 08108830
 - Dayton/Batco 08108831
 - Dayton/Batco 08108838
 - Dayton/Batco 08108865
 - Dayton/Batco 08108875
 - Dayton/Batco 081092
 - Dayton/Batco 081126
 - Dayton/Batco 081132
 - Dana/Spicer 28A
 - Dana/Spicer 29A
 - Trailmobile 382769
 - Trailmobile 382769HD
 - Dana/Spicer 64A
 - Haldex CQ66867
 - Dana/Spicer HK29
 - Dana/Spicer HK29BULK
 - Dana/Spicer HK29SD
 - Dana/Spicer HK29XLS
 - Leland K128K
 - Leland K339
 - Dexter K7113600
 - Meritor KIT8000
 - Meritor KIT8000BK
 - Meritor KIT8000BULK
 - Meritor KIT8000HD
 - Meritor KIT8000HDBK
 - Meritor KIT8000HDBULK
 - Fruehauf MRS008000
 - Sirco QK1MPHD
 - Sirco QKINT
 - Hendrickson Turner S23752

*Not Sold Separately

E-2769S

STOPMATE PLUS

BRAKE REPAIR KITS

HENDRICKSON, MERITOR and SPICER (DANA) 16-1/2" BRAKES

APPLICATION & GENERAL INFORMATION

ITEM	QTY	EUCLID NO.	DESCRIPTION
1	2	E-2766S	Anchor Pin
2	2	E-1893S	Anchor Pin Bushing
3	2	E-2767	Retainer Spring
4	1	E-2768	Return Spring
5	2	E-11741	Roller
6	2	E-747	Spring Retainer
7	2	E-3007A	Roller Retainer

For Meritor "Q" and Q Plus™, Spicer (Dana) "Fast Change" and "XLII", and Hendrickson Intraax® brakes. Contains new Posi-Plus roller. For use with the following Brake Shoes: E-3303 (5"), E-3304 (6"), E-2778 (7"), E-6075 (7"), E-3522 (8-5/8"), E-3417 (10").
 Note: To insure quick brake release and full lining life, Q Plus™ brakes use only heavy-duty return springs.

REPLACES:

- Dayton/Batco 081088
- Dayton/Batco 08108801
- Dayton/Batco 08108805
- Dayton/Batco 081702
- Eaton 126131
- Dana/Spicer 281A
- Dana/Spicer 281ABULK
- Dana/Spicer 281AR
- Dana/Spicer 281ARBULK
- Trailmobile 382769S
- Sirco 45154707Q
- Eaton 5-2245
- Eaton 52245B
- Haldex 66861
- Trailmobile 70017259
- Trailmobile 7007235
- Trailmobile 7007255
- Wagner 911005
- Haldex CQ66861
- Dana/Spicer HK29
- Leland K117
- Leland K306
- Leland K339
- Leland K70
- Meritor KIT8000
- Meritor KIT8000A
- Meritor KIT8000BK
- Fruehauf MBCBK0020
- Fruehauf MRS008000
- Sirco QK1
- Meritor R508000
- Meritor R508000BK
- Meritor R508000BULK
- Trailmobile RWKIT8000



BRAKE REPAIR KITS

E-2769SHD

STOPMATE PLUS

HENDRICKSON, MERITOR and SPICER (DANA) 16-1/2" BRAKES

APPLICATION & GENERAL INFORMATION

ITEM	QTY	EUCLID NO.	DESCRIPTION
1	2	E-2766S	Anchor Pin
2	2	E-1893S	Anchor Pin Bushing
3	2	E-2767	Retainer Spring
4	1	E-3490S	Return Spring
5	2	E-11741	Roller
6	2	E-747	Spring Retainer
7	2	E-3007A	Roller Retainer

For Meritor "Q" and Q Plus™, Spicer (Dana) "Fast Change" and "XLII", and Hendrickson Intraax® brakes. Contains new Posi-Plus roller. Same as E-2769S except has Heavy Duty Return Spring. For use with the following Brake Shoes: E-3303 (5"), E-3304 (6"), E-2778 (7"), E-3522 (8-5/8"), E-3417 (10"). Note: To insure quick brake release and full lining life, Q Plus™ brakes use only heavy-duty return springs.

REPLACES:

Dayton/Batco 08108800, 08108838,08108865, 081132, 081703
 Dana/Spicer 291A, 291ABULK, 291AR, 291ARBULK, TA291A
 Sirco 45154707QHD
 Haldex 66867, CQ66867, WKH1EZT, E2769SHDR
 Leland K128, K128K, K329, K332, 4515AQHD
 Meritor KIT8000HD, KIT8000HDBK, R508001, R508001BK, R508001BULK



E-6999S

STOPMATE PLUS

HENDRICKSON, MERITOR and SPICER (DANA) 16-1/2" BRAKES

APPLICATION & GENERAL INFORMATION

ITEM	QTY	EUCLID NO.	DESCRIPTION
1	2	E-2766S	Anchor Pin
2	2	E-2767	Retainer Spring
3	1	E-2768	Return Spring
4	2	E-11741	Roller
5	2	E-747	Spring Retainer
6	2	E-3007A	Roller Retainer

For Meritor "Q" and Q Plus™, Spicer (Dana) "Fast Change" and "XLII", and Hendrickson Intraax® brakes. Same as E-2769S minus Bushings. Contains new Posi-Plus roller. For use with the following Brake Shoes: E-3303 (5"), E-3304 (6"), E-2778 (7"), E-6075 (7"), E-3522 (8-5/8"), E-3417 (10").

REPLACES:

Dayton/Batco 08108810, 08108815,08108815, 081425, 081700
 Dana/Spicer 30A, 30AR, HK29
 Leland K321, K70A
 Meritor KIT8000MB , KIT8000MBA
 Meritor KIT8000MBBK, KIT8000MBBULK
 Meritor R508002, R508002BK, R508002BULK
 Sirco QK-2, QK8, QK8A



BRAKE REPAIR KITS

E-6999SHD

STOPMATE PLUS

HENDRICKSON, MERITOR and SPICER (DANA) 16-1/2" BRAKES

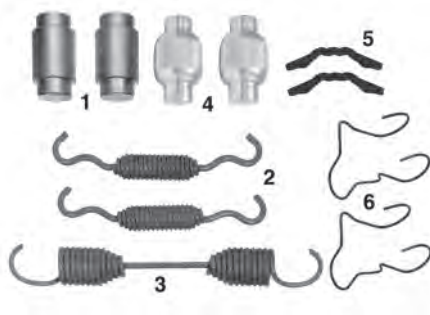

ITEM	QTY	EUCLID NO.	DESCRIPTION
1	2	E-2766S	Anchor Pin
2	2	E-2767	Retainer Spring
3	1	E-3490S	Return Spring
4	2	E-11741	Roller
5	2	E-747	Spring Retainer
6	2	E-3007A	Roller Retainer

APPLICATION & GENERAL INFORMATION

For Meritor "Q" and Q Plus™, Spicer (Dana) "Fast Change" and "XLI", and Hendrickson Intraax® brakes. Same as E-2769S minus Bushings. Same as E-6999S except has Heavy Duty Return Spring. Contains new Posi-Plus roller. For use with the following Brake Shoes: E-3303 (5"), E-3304 (6"), E-2778 (7"), E-6075 (7"), E-3522 (8-5/8"), E-3417 (10").

REPLACES:

Dayton/Batco 08108845, 081701
 Leland 4515AQM, K128A
 Meritor R508003
 Meritor R508003BK
 Meritor R508003BULK
 Meritor KIT8000MBHD
 Meritor KIT8000MBHDBK
 Sirco QK1A, QK2HD, QK8HD

E-2676

MEGA PLUS

MACK 16-1/2" OLD STYLE CAST BRAKE

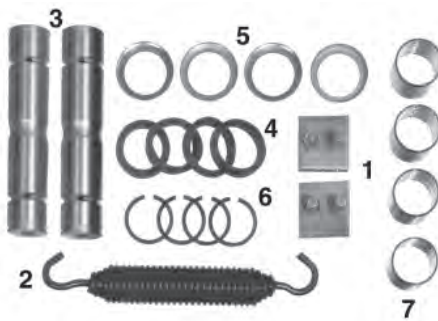

ITEM	QTY	EUCLID NO.	DESCRIPTION
1	2	E-714	Brake Shoe Wear Pad
2	1	E-752	Return Spring
3	2	NSS*	Anchor Pin
4	4	E-537	Anchor Pin Felt
5	4	E-671	Felt Retainer
6	4	E-5093	Camshaft Lock Ring
7	4	E-530	Brake Shoe Bushing

APPLICATION & GENERAL INFORMATION

For use with Mack's own Old Style cast shoe with wear plates

REPLACES:

Dayton/Batco 081081
 Dayton/Batco 08108110
 Meritor R507069

*Not Sold Separately

BRAKE REPAIR KITS

E-5086

MEGA PLUS

MACK WITH MERITOR 16-1/2" "Q" BRAKE WITH 50,000 LB. REAR AXLE APPLICATION & GENERAL INFORMATION



ITEM	QTY	EUCLID NO.	DESCRIPTION
1	2	E-5087	Anchor Pin
2	2	E-8938	Anchor Pin Bushing
3	2	E-5088	Retainer Spring
4	1	E-3490B	100 lb Return Spring
5	2	E-5089	Roller
6	2	E-3007A	Roller Retainer
7	2	E-747	Spring Retainer
8	2	NSS*	Retainer Pin Spring
9	2	E-5091	Lock Ring
10	1	E-3887	Anti-Seize Compound

For use with the following Brake Shoe:
E-5092 (7")
REPLACES:
Dayton/Batco 081115
08111500
Dana/Spicer 82A, TA82A
Haldex CQ62767
Leland K293
Meritor KIT8026HD
Sirco MK2

E-2675HD

MEGA PLUS

MACK WITH MERITOR 16-1/2" BRAKE

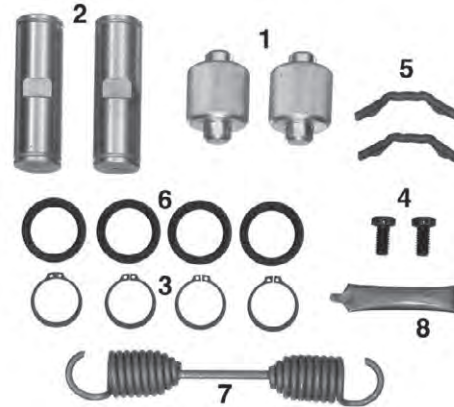

ITEM	QTY	EUCLID NO.	DESCRIPTION
1	2	E-3914	Roller
2	2	E-502	Anchor Pin
3	4	E-801	Lock Ring
4	2	E-579A	Anchor Pin Lock Screw
5	2	E-747	Spring Retainer
6	4	E-1269	Anchor Pin Seal
7	1	E-1880B	Return Spring
8	1	E-3887	Anti-Seize Compound

APPLICATION & GENERAL INFORMATION

Antiseize Lubricate not sold separately.
REPLACES:
Dayton/Batco 081083, 08108300
Haldex 67356, CQ67356
Wagner 911004
Leland K77
Meritor R509406
Meritor KIT9003
Meritor KIT9406
Sirco MK1, MK1HD

E-11974

MERITOR 16-1/2" P



ITEM	QTY	EUCLID NO.	DESCRIPTION
1	4	NSS*	Snap Ring
2	4	E-537	Anchor Pin Felt
3	4	NSS*	Felt Retainer
4	2	NSS*	Roller
5	1	E-5212	Return Spring
6	2	NSS*	Bushing
7	2	E-3513	Retaining Clip
8	2	NSS*	Anchor Pin

APPLICATION & GENERAL INFORMATION

Drive axle, Cast P series brake shoes.
Services 1 brake.

*Not Sold Separately

BRAKE REPAIR KITS

KIT-4HD

MEGA PLUS

MERITOR 16-1/2" "P" SERIES and STD. FORGE EARLY MODEL BRAKE



ITEM	QTY	EUCLID NO.	DESCRIPTION	APPLICATION & GENERAL INFORMATION
2	2	E-11741	Roller	Contains new Posi-Plus roller.
3	1	E-1880B	Return Spring	For use with the following Brake Shoes: E-2686 (4"), E-2687 (5"),
4	2	E-3007A	Roller Retainer	E-3418 (5"), E-2684 (6"), E-2241
5	4	E-801	Lock Ring	(7"), E-5239 (8-5/8"), E-2496
6	2	E-579A	Anchor Pin Lock Screw	(10")
7	4	E-1269	Anchor Pin Seal	REPLACES
8	2	E-747	Spring Retainer	Dayton/Batco 081001, 081002, 081038, 081120
9	1	E-3887	Anti-Seize Compound	Haldux CQ67390 Dana/Spicer HK16, HK16XLS, TA23A Leland K44B, K59 Meritor KIT9002, KIT9002N, KIT9017, KIT9017N, KIT9017NC, KIT9063, KIT9063BK, KIT9063BULK, KIT9063N, KIT9063NBK, R509002, R509063 Sirco TFINT, TK4MPHD

KIT-4S

STOPMATE PLUS

MERITOR 16-1/2" "P" SERIES and STD. FORGE EARLY MODEL BRAKE



ITEM	QTY	EUCLID NO.	DESCRIPTION	APPLICATION & GENERAL INFORMATION
1	2	E-512	Anchor Pin	
2	2	E-11741	Roller	Contains new Posi-Plus roller.
3	1	E-545A	Return Spring	For use with the following Brake Shoes: E-2686 (4"), E-2687 (5"),
4	2	E-3007A	Roller Retainer	E-3418 (5"), E-2684 (6"), E-2241
5	4	E-801	Lock Ring	(7"), E-5239 (8-5/8"),
6	2	E-579A	Anchor Pin Lock Screw	E-2496 (10")
7	4	E-1269	Anchor Pin Seal	REPLACES:
8	2	E-747	Spring Retainer	Dayton/Batco 081001, 08100100, 081044, 081419, 081706, 81417 Eaton 122844, 5-2236, 52236B Dana/Spicer 163A, 164A, 164ABULK, 16A, HK16XLS, TA23A Haldux 67315, CQ67315 Wagner 911000 Leland K44A, K59 Meritor KIT9002, KIT9002N, KIT9017, KIT9017N, KIT9017NBK, KIT 9017NC, KIT9017NBULK, R509000, R509002 Trailmobile RWKIT9017N Sirco TK1, TK2

BRAKE REPAIR KITS

KIT-4SHD

STOPMATE PLUS

MERITOR 16-1/2" "P" SERIES and STD. FORGE EARLY MODEL BRAKE



ITEM	QTY	EUCLID NO.	DESCRIPTION
1	2	E-512S	Anchor Pin
2	2	E-11741	Roller
3	1	E-1880S	Return Spring
4	2	E-3007A	Roller Retainer
5	4	E-801	Lock Ring
6	2	E-579A	Anchor Pin Lock Screw
7	4	E-1269	Anchor Pin Seal
8	2	E-747	Spring Retainer

APPLICATION & GENERAL INFORMATION

Contains new Posi-Plus roller.
 For use with the following Brake Shoes: E-2686 (4"), E-2687 (5"), E-3418 (5"), E-2684 (6"), E-2241 (7"), E-5239 (8-5/8"), E-2496 (10"). Same as KIT-4S except has Heavy Duty Return Spring.
REPLACES:
 Dayton/Batco 08100160, 081002, 081707
 Eaton 123209, 5-2237, 52237B
 Dana/Spicer 161A, 164A, 16A, 16ABULK, HK16SD
 Haldex 67356, CQ67390
 Trailmobile 7007200
 Wagner 911003
 Navistar IT163A
 Leland K115, K44, K44B
 Meritor R509001, R509002, KIT9017NHD, KIT9017NHDBK
 Fruehauf MBCBK0027
 Sirco TK1HD

E-9070

MEGA PLUS

MERITOR 16-1/2" "Q" BRAKE WITH "FL" SERIES FRONT AXLES

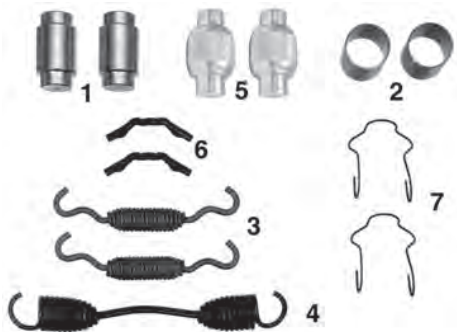

ITEM	QTY	EUCLID NO.	DESCRIPTION
1	2	E-2766S	Anchor Pin
2	2	E-1893	Anchor Pin Bushing
3	2	E-2767	Retainer Spring
4	1	E-9069	Return Spring
5	2	E-11741	Roller
6	2	E-747	Spring Retainer
7	2	E-3007A	Roller Retainer

APPLICATION & GENERAL INFORMATION

Contains new Posi-Plus roller.
 For use with the following Brake Shoes: E-3303 (5"), E-3823 (5"), E-3304 (6")
REPLACES:
 Dana/Spicer 80A
 Haldex CQ66889
 Dana/Spicer HK80XLS
 Leland K366
 Meritor KIT8037
 Sirco MF3

BRAKE REPAIR KITS

E-1607HD

MEGA PLUS

MERITOR 16-1/2" BRAKE SHOES WITH REINFORCED ANCHOR BOSSES

APPLICATION & GENERAL INFORMATION



ITEM	QTY	EUCLID NO.	DESCRIPTION
1	2	E-502	Anchor Pin
2	2	E-11741	Roller
3	1	E-1880B	Return Spring
4	2	E-3007A	Roller Retainer
5	4	E-1269	Anchor Pin Seal
6	4	E-801	Lock Ring
7	2	E-579A	Anchor Pin Lock Screw
8	2	E-747	Spring Retainer
9	1	E-3887	Anti-Seize Compound

Contains new Posi-Plus roller.
REPLACES:
Dayton/Batco 081082,
08108200, 08108260
Dana/Spicer 192A, 19A
Haldex 67357
Wagner 911008
Haldex CQ67357
Navistar IT192A
Leland K46, K61
Meritor KIT9004, KIT9409,
R509409
Dana/Spicer M16LK104X
TA192A
Sirco TK7, TK7HD, TK7HD10

E-9644

MEGA PLUS

MERITOR 16-1/2" STEER AXLE BRAKE

APPLICATION & GENERAL INFORMATION



ITEM	QTY	EUCLID NO.	DESCRIPTION
1	2	E-2766S	Anchor Pin
2	2	E-1893	Anchor Pin Bushing
3	2	E-2767	Retainer Spring
4	1	E-9643	Return Spring
5	2	E-11741	Roller
6	2	E-747	Spring Retainer
7	2	E-3007A	Roller Retainer

For use with relocated return spring shoes and Q Plus™ camshafts. Can also be used on "Hammer Claw" camshaft.
Important Note: Spring must be installed with end hook open toward camshaft head. Contains new Posi-Plus roller. For use with the following Brake Shoes: E-3823 (5"), E-9780 (6"). Double Web "Q" Brake Shoe used on Mack Front Axles.
REPLACES:
Dayton/Batco 08108850,
08111600, 08111630
Dana/Spicer 81A
Haldex CQ66887
Dana/Spicer HK81XLS
Leland K292, K334
Meritor KIT8081, R508053
Sirco MF1, MF2

E-5515

MEGA PLUS

SPICER 16-1/2" "XL" "XTRALIFE" BRAKE

APPLICATION & GENERAL INFORMATION



ITEM	QTY	EUCLID NO.	DESCRIPTION
1	2	E-2766S	Anchor Pin
2	2	E-8938	Anchor Pin Bushing
3	2	E-2767	Retainer Spring
4	1	E-1880B	Return Spring
5	2	E-1582	Roller
6	2	E-747	Spring Retainer
7	2	E-539	Roller Retainer
8	1	E-3887	Anti-Seize Compound

For use with following Brake Shoe: E-2778 (7"). Can be used only with Spicer "XL" Camshafts.
REPLACES:
Dayton/Batco 081162
Dayton/Batco 08116200
Dana/Spicer 29XL
Haldex CQ65515
Dana/Spicer HK32SD
Leland K305
Meritor R507063
Sirco XL1

BRAKE REPAIR KITS

E-3895S

STOPMATE PLUS

UNIVERSAL 16-1/2" QUICK CHANGE SERIES BRAKE

APPLICATION & GENERAL INFORMATION

ITEM	QTY	EUCLID NO.	DESCRIPTION
1	2	E-2767	Retainer Spring
2	1	E-2768	Return Spring
3	2	E-11741	Roller
4	2	E-747	Spring Retainer
5	2	E-3007A	Roller Retainer

Contains new Posi-Plus roller. For use with all Meritor "Q" Brake Shoes. Can also be used for all Fruehauf "XEM" and Spicer "Fast Change" Shoes.

- REPLACES:
- Dayton/Batco 08108812
 - Dayton/Batco 08108817
 - Dayton/Batco 081428
 - Dana/Spicer 38A
 - Sirco 4515QMM
 - Dana/Spicer HK38
 - Leland K125
 - Leland K303
 - Meritor KIT8014
 - Fruehauf MBCBK0021
 - Sirco QK2
 - Sirco QK2S
 - Meritor R508014
 - Meritor R508014BK
 - Meritor R508014BULK
 - Sirco XK3S

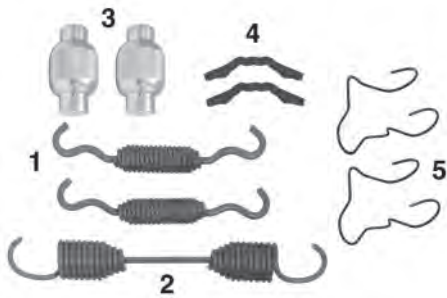

E-3895SHD

STOPMATE PLUS

UNIVERSAL 16-1/2" QUICK CHANGE SERIES BRAKE

APPLICATION & GENERAL INFORMATION

ITEM	QTY	EUCLID NO.	DESCRIPTION
1	2	E-2767	Retainer Spring
2	1	E-3490S	Return Spring
3	2	E-11741	Roller
4	2	E-747	Spring Retainer
5	2	E-3007A	Roller Retainer

Contains new Posi-Plus roller. For use with all Meritor "Q" Brake Shoes. Can also be used for all Fruehauf "XEM" and Spicer "Fast Change" Shoes. Same as E-3895S except has Heavy Duty Return Spring.

- REPLACES:
- Dayton/Batco 08108847
 - Dayton/Batco 081704
 - Trailmobile 383895SHD
 - Dana/Spicer 38A
 - Sirco 45154707QM
 - Sirco 4515QMMHD
 - Dana/Spicer HK74XLS
 - Leland K304
 - Meritor KIT8014HD
 - Sirco QK2HD
 - Sirco QK2SHD
 - Meritor R508015
 - Meritor R508015BK
 - Meritor R508015BULK

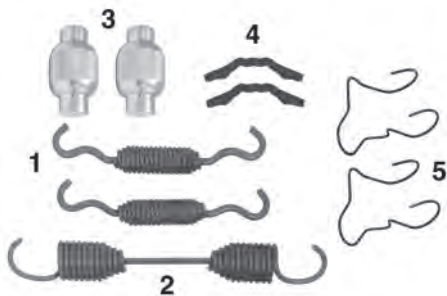

BRAKE REPAIR KITS

E-4515U

STOPMATE

UNIVERSAL 16-1/2" QUICK CHANGE SERIES BRAKE

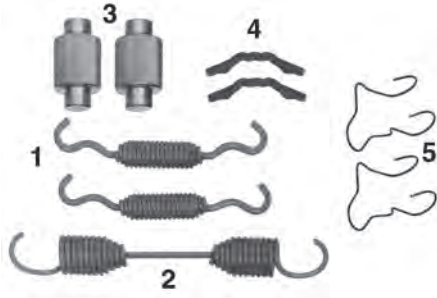

ITEM	QTY	EUCLID NO.	DESCRIPTION
1	2	NSS*	Retainer Spring
2	1	NSS*	Return Spring
3	2	E-2177	Roller
4	2	E-747	Spring Retainer
5	2	E-3007A	Roller Retainer

APPLICATION & GENERAL INFORMATION

Stopmate version of E-3895S.
 REPLACES:
 Dayton/Batco 08108812
 Dayton/Batco 08108817
 Dana/Spicer 38A
 Sirco 4515QMM
 Dana/Spicer E4515U
 Dana/Spicer HK38
 Leland K125, K303
 Meritor MKT4515U
 Sirco QK2, QK2S, XK3S

E-4515UHD

STOPMATE

UNIVERSAL 16-1/2" QUICK CHANGE SERIES BRAKE

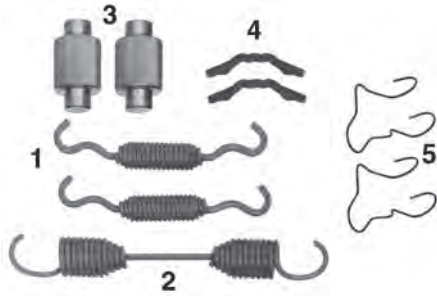

ITEM	QTY	EUCLID NO.	DESCRIPTION
1	2	NSS*	Retainer Spring
2	1	NSS*	Return Spring
3	2	E-2177	Roller
4	2	E-747	Spring Retainer
5	2	E-3007A	Roller Retainer

APPLICATION & GENERAL INFORMATION

Stopmate version of E-3895SHD.
 REPLACES:
 Dayton/Batco 08108847
 Dayton/Batco 081704
 Sirco 4515QMMHD
 Leland K304
 Hercules KIT#1A
 Meritor MKT4515UHD
 Sirco QK2HD
 Sirco QK2SHD

*Not Sold Separately

BRAKE REPAIR KITS

E-1816S

STOPMATE PLUS

UNIVERSAL KIT W/"FREE-FLOATING" ANCHOR PIN FOR 16-1/2" BRAKES

ITEM	QTY	EUCLID NO.	DESCRIPTION
1	2	E-1112A	Anchor Pin
2	4	E-1113	Washer
3	4	E-801	Lock Ring
4	2	E-11741	Roller
5	1	E-545A	Return Spring
6	2	E-3007A	Roller Retainer
7	2	E-1893S	Anchor Pin Bushing
8	2	E-747	Spring Retainer

APPLICATION & GENERAL INFORMATION

For Eaton, Fruehauf, Meritor, Spicer (Dana) and Std. Forge Brakes. Contains new Posi-Plus roller. For use with the following Brake Shoes: E-2686 (4"), E-2687 (5"), E-3418 (5"), E-2684 (6"), E-2241 (7"), E-2685 (7"), E-5239 (8-5/8"), E-2496 (10")

- REPLACES:
- Dayton/Batco 081001
 - Dayton/Batco 081003
 - Dayton/Batco 08100300
 - Dayton/Batco 081038
 - Dayton/Batco 081047
 - Dayton/Batco 081716
 - Eaton 123574
 - Dana/Spicer 13A
 - Dana/Spicer 142A
 - Dana/Spicer 143A
 - Dana/Spicer 143ABULK
 - Dana/Spicer 163A
 - Trailmobile 381816S
 - Eaton 5-2238
 - Eaton 52238B
 - Haldex 67315
 - Haldex 67317
 - Haldex 67352
 - Trailmobile 70017290
 - Trailmobile 7007258
 - Wagner 911019
 - Haldex CQ67317
 - Haldex CQ67435
 - Dana/Spicer HK14XLS
 - Leland K60
 - Leland K75
 - Meritor KIT9000
 - Dana/Spicer M16LK103X
 - Meritor R509000
 - Meritor R509000BK
 - Meritor R509000BULK
 - Sirco TK4



BRAKE REPAIR KITS

E-1816SHD

STOPMATE PLUS

UNIVERSAL KIT W/"FREE-FLOATING" ANCHOR PIN FOR 16-1/2"

ITEM	QTY	EUCLID NO.	DESCRIPTION
1	2	E-1112A	Anchor Pin
2	4	E-1113	Washer
3	4	E-801	Lock Ring
4	2	E-11741	Roller
5	1	E-1880S	Return Spring
6	2	E-3007A	Roller Retainer
7	2	E-1893S	Anchor Pin Bushing
8	2	E-747	Spring Retainer

APPLICATION & GENERAL INFORMATION

For Eaton, Fruehauf, Meritor, Spicer (Dana) and Std. Forge Brakes. Contains new Posi-Plus roller. For use with the following Brake Shoes: E-2686 (4"), E-2687 (5"), E-3418 (5"), E-2684 (6"), E-2241 (7"), E-2685 (7"), E-5239 (8-5/8"), E-2496 (10")

REPLACES:

Dayton/Batco 08100160
 Dayton/Batco 08100360
 Dayton/Batco 081004
 Dayton/Batco 081035
 Dayton/Batco 081717
 Eaton 123939
 Dana/Spicer 144A
 Dana/Spicer 144ABULK
 Dana/Spicer 14A
 Trailmobile 381816SHD
 Eaton 5-2239
 Eaton 52239B
 Haldex 66735
 Trailmobile 7007201
 Wagner 911020
 Haldex CQ66735
 Navistar IT14A
 Leland K109
 Leland K116
 Leland K45
 Meritor KIT9001
 Fruehauf MBCBK0022
 Fruehauf MRS009001
 Meritor R5090001
 Meritor R509001
 Meritor R509001BK
 Meritor R509001BULK
 Dana/Spicer TA144A
 Dana/Spicer TA14A
 Sirco TK4HD



BRAKE REPAIR KITS

E-1816HD

MEGA PLUS

UNIVERSAL KIT WITH "FREE-FLOATING" ANCHOR PIN FOR 16-1/2" BRAKES

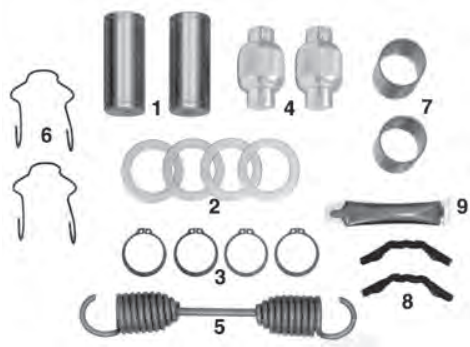

ITEM	QTY	EUCLID NO.	DESCRIPTION
1	2	E-1112A	Anchor Pin
2	4	E-1113	Washer
3	4	E-801	Lock Ring
4	2	E-11741	Roller
5	1	E-1880B	Return Spring
6	2	E-3007A	Roller Retainer
7	2	E-8938	Anchor Pin Bushing
8	2	E-747	Spring Retainer
9	1	E-3887	Anti-Seize Compound

APPLICATION & GENERAL INFORMATION
 For Eaton, Fruehauf, Meritor, Spicer (Dana) and Std. Forge Brakes. Contains new Posi-Plus roller. Use with the following Brake Shoes: E-2686 (4"), E-2687 (5"), E-3418 (5"), E-2684 (6"), E-2241 (7"), E-2685 (7"), E-5239 (8-5/8"), E-2496 (10"). Same as E-1816S except has Heavy Duty Return Spring
REPLACES:
 Dayton/Batco 08100100
 Dayton/Batco 081003
 Dayton/Batco 08100305
 Dayton/Batco 081036
 Dayton/Batco 081103
 Dayton/Batco 081121
 Dana/Spicer 141A
 Dana/Spicer 142A
 Dana/Spicer 14A
 Trailmobile 381816HD
 Haldex CQ66735
 Dana/Spicer HK14SD
 Dana/Spicer HK14XLS
 Leland K75
 Leland K9001
 Meritor KIT9000
 Meritor KIT9001
 Dana/Spicer M16LK103X
 Fruehauf MRS009001
 Meritor R509000
 Meritor R509001
 Trailmobile RWKIT9000
 Sirco TK4MPHD

E-4515P

STOPMATE

UNIVERSAL KIT WITH "FREE-FLOATING" ANCHOR PIN FOR 16-1/2" BRAKES



ITEM	QTY	EUCLID NO.	DESCRIPTION
1	2	E-1112A	Anchor Pin
2	4	E-1113	Washer
3	4	E-801	Lock Ring
4	2	E-2177	Roller
5	1	E-545A	Return Spring
6	2	E-3007A	Roller Retainer
7	2	E-1893S	Anchor Pin Bushing
8	2	E-747	Spring Retainer

APPLICATION & GENERAL INFORMATION
 For Eaton, Fruehauf, Meritor, Spicer (Dana) and Std. Forge brakes. Stopmate version of E-1816S.
REPLACES:
 Dayton/Batco 08100300
 Dayton/Batco 081047
 Dayton/Batco 081716
 Haldex 67317
 Haldex 67352
 Haldex CQ67317
 Haldex CQ67435
 Leland K60
 Meritor MKT4515P
 Sirco TK4

BRAKE REPAIR KITS

E-4515PHD

STOPMATE

UNIVERSAL KIT WITH "FREE-FLOATING" ANCHOR PIN FOR 16-1/2" BRAKES



ITEM	QTY	EUCLID NO.	DESCRIPTION
1	2	E-1112A	Anchor Pin
2	4	E-1113	Washer
3	4	E-801	Lock Ring
4	2	E-2177	Roller
5	1	E-1880S	Return Spring
6	2	E-3007A	Roller Retainer
7	2	E-1893S	Anchor Pin Bushing
8	2	E-747	Spring Retainer

APPLICATION & GENERAL INFORMATION

For Eaton, Fruehauf, Meritor, Spicer (Dana) and Std. Forge brakes. Stopmate version of E-1816SHD.
 REPLACES:
 Dayton/Batco 08100100
 Dayton/Batco 08100160
 Dayton/Batco 08100305
 Dayton/Batco 08100360
 Dayton/Batco 081035
 Dayton/Batco 081717
 Haldex 66735
 Haldex CQ66735
 Leland K109
 Leland K116
 Leland K45
 Leland K75
 Leland K9001
 Meritor MKT4515PHD
 Sirco TK4HD
 Sirco TK4MPHD

E-2821

MEGA PLUS

EATON 18" SINGLE ANCHOR PIN BRAKE WITH CAST SHOES



ITEM	QTY	EUCLID NO.	DESCRIPTION
1	2	E-2805	Retainer Spring
2	1	E-2804	Return Spring
3	2	E-2802	Roller
4	2	E-2803	Roller Pin

APPLICATION & GENERAL INFORMATION

For use with the following Brake Shoe: E-2801 (7")
 REPLACES:
 Dayton/Batco 081096
 Dayton/Batco 08109600
 Eaton 1005006
 Dana/Spicer 26A
 Trailmobile 382821
 Haldex CQ67406
 Sirco EK2
 Dana/Spicer HK26
 Leland K275
 Meritor R507072

E-3992

MEGA PLUS

MERITOR 18" WITH NEW STYLE CAST SHOES

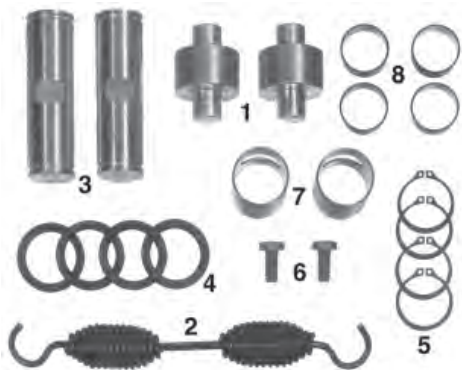

ITEM	QTY	EUCLID NO.	DESCRIPTION
1	2	E-3511	Roller
2	1	E-543	Return Spring
3	2	E-502	Anchor Pin
4	4	E-1269	Anchor Pin Seal
5	4	E-801	Lock Ring
6	2	E-579A	Anchor Pin Lock Screw
7	2	E-919	Anchor Pin Bushing
8	4	E-2218	Brake Shoe Bushing

APPLICATION & GENERAL INFORMATION

For use with the following Brake Shoe: E-4902 (7")
 REPLACES:
 Dayton/Batco 081098
 Dayton/Batco 08109800
 Haldex CQ67408
 Leland K281
 Meritor KIT9408
 Meritor R509408
 Sirco RK2

BRAKE REPAIR KITS

E-3518

MEGA PLUS

MERITOR 18" WITH OLD STYLE CAST SHOES



ITEM	QTY	EUCLID NO.	DESCRIPTION
1	2	E-3511	Roller
2	2	E-3513	Retainer
3	1	E-3512	Return Spring
4	2	E-502	Anchor Pin
5	4	E-801	Lock Ring
6	2	E-579A	Anchor Pin Lock Screw
7	4	E-1269	Anchor Pin Seal
8	4	E-2218	Brake Shoe Bushing

APPLICATION & GENERAL INFORMATION

For use with the following Brake Shoe: E-4902 (7")
 REPLACES:
 Dayton/Batco 08109830
 Dayton/Batco 081105
 Dayton/Batco 16119081
 Dana/Spicer 68A
 Haldex CQ67407
 Dana/Spicer HK68
 Leland K274
 Meritor KIT9179
 Sirco RK1
 Dana/Spicer TA68A

E-5499

MEGA PLUS

SPICER (STD. FORGE) 18" WITH FABRICATED SHOES

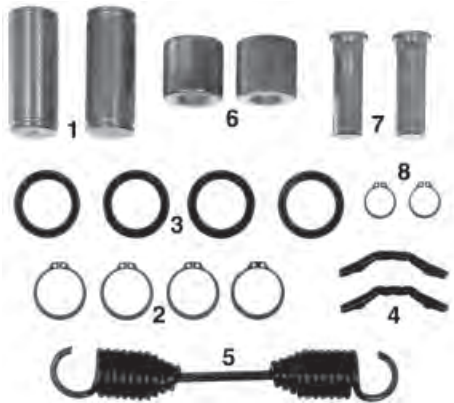

ITEM	QTY	EUCLID NO.	DESCRIPTION
1	2	E-512S	Anchor Pin
2	4	E-801	Lock Ring
3	4	E-1269	Anchor Pin Seal
4	2	E-747	Spring Retainer
5	1	E-1880B	Return Spring
6	2	E-2395	Roller
7	2	E-2396	Roller Pin
8	2	E-527	Roller Pin Retainer

APPLICATION & GENERAL INFORMATION

For use with the following Brake Shoe: E-5500 (7")
 REPLACES:
 Dayton/Batco 081095
 Dayton/Batco 08109500
 Dayton/Batco 08109560
 Dana/Spicer 27A
 Haldex CQ65521
 Dana/Spicer HK27
 Meritor R507079
 Sirco SK1

ROLLERS

"POSI-PLUS" DIAMOND KNURLED Roller - For Fabricated Brake Shoes



EUCLID NO.	OVERALL LENGTH	LENGTH OF LARGE DIA.	O.D.	REPLACES	APPLICATION AND GENERAL INFORMATION
E-11741	2-1/4"	1-5/16"	1-1/4"	2297-T-7222 (not knurled)	Heat Treat: carburized & harden Zinc Plate and Clear Chromate

"POSI-ROLL" DIAMOND KNURLED ROLLERS - For Fabricated Brake Shoes



EUCLID NO.	OVERALL LENGTH	LENGTH OF LARGE DIA.	O.D.	REPLACES	APPLICATION AND GENERAL INFORMATION
E-5477	2-5/32"	1-1/4"	1-1/4"	Dayton/Batco 01247 Eaton 2806234 Dana/Spicer 321471 Sirco B430K Haldex C63015 Leland L2960 Meritor R517510	For Eaton 16-1/2" "ES" Brake. Zinc Yellow Dichromate
E-2177	2-7/32"	1-9/32"	1-1/4"	Dayton/Batco 01234 Dayton/Batco 1200 Meritor 1779R18 Dana/Spicer 19912 Eaton 2-2107 Standard Forge 204101001 GMC 2295551 Dana/Spicer 321428 Fruehauf 330733 Holland Hitch 330733X Trailmobile 382177 Trailmobile 39286 Haldex 66901 Trailmobile 7-23-7 Trailmobile 7007206 Eaton 75638 Wagner 914000 Sirco B911 Haldex C66901 Navistar IT321428 Leland L1533 Dana/Spicer M16WJ104	Same application as E-523.
E-2215	2-7/32"	1-9/32"	1-3/8"	Dayton/Batco 1201 Meritor 1779C81 Wagner 914001 Haldex C65435 Leland L1717	1/8" Oversize of E-2177.
E-3914	2-17/64"	1-1/2"	1-5/8"	Meritor 1199A3719 Dayton/Batco 1229 Wagner 914002 Haldex C67366	Same application as E-2672.

ROLLERS - For Fabricated Brake Shoes



EUCLID NO.	OVERALL LENGTH	LENGTH OF LARGE DIA.	O.D.	REPLACES	APPLICATION AND GENERAL INFORMATION
E-10812	1-47/64"	47/64"	1-1/2"	Meritor 1779J114 Sirco BP105 Leland L260 Eaton 820165	For Meritor 14-1/2" x 5" "W" Series.
E-2208	2"	7/8"	1-1/4"	Eaton B2011 Leland L1599 Meritor R517005	For Eaton 12-1/4" Brake Shoes.

ROLLERS

ROLLERS - For Fabricated Brake Shoes

EUCLID NO.	OVERALL LENGTH	LENGTH OF LARGE DIA.	O.D.	REPLACES	APPLICATION AND GENERAL INFORMATION
E-1406	2"	7/8"	1-1/2"	Dayton/Batco 01225 Dana/Spicer 321429 Eaton 820165 Sirco B425 Haldex C66650 Leland L1600 Meritor R517005	1/4" Oversize Version of E-2208.
E-10239	2-5/32"	1-1/4"	1-1/4"	Sirco B430	For Eaton 16-1/2" "ES" Brake. Zinc Yellow Dichromate
E-3511	2-3/16"	15/16"	1-5/8"	Dayton/Batco 01236 Meritor 1199U3765 Dana/Spicer 321458 Haldex 66610 Sirco B923 Haldex C66610 Leland L1646	For Meritor 18" x 7" Cast Brake Shoes.
E-1582	2-7/32"	1-1/4"	1"	Dayton/Batco 01227 Dana/Spicer 321430 Fruehauf ACD002232001 Fruehauf ACD002232PK1 Sirco B054 Haldex C67447 Navistar IT321430 Leland L1696 Dana/Spicer M16WJ121 Meritor R517002	For "Pro-Par" Axle with 12-1/4" Brakes and Spicer "XL" "XtraLife" Brakes.
E-523	2-7/32"	1-9/32"	1-1/4"	Dayton/Batco 01200 Dayton/Batco 01246 Navistar 126404R1 Meritor 1779B1172 Meritor 1779R18 Trailmobile 19132 Standard Forge 204101001 GMC 2295551 Dana/Spicer 321425 Fruehauf 330733 Holland Hitch 330733X Trailmobile 38523 Trailmobile 39286 Haldex 65326 Trailmobile 7-23-7 Trailmobile 700720 Wagner 914003 Fruehauf ACE009910001 Sirco B251 Sirco B941 Haldex C66911 Leland L149 Dana/Spicer M16WJ104	For 16-1/2" Brakes with Fabricated Brake Shoes.
E-781	2-7/32"	1-9/32"	1-3/8"	Dayton/Batco 01201 Meritor 1779C81 Trailmobile 19171 Dana/Spicer 321426 Trailmobile 38781 Haldex 65435 Wagner 914004 Sirco B611 Navistar IT321426 Leland L294	1/8" Oversize Version of E-523.



ROLLERS

ROLLERS - FOR FABRICATED BRAKE SHOES



EUCLID NO.	OVERALL LENGTH	LENGTH OF LARGE DIA.	O.D.	REPLACES	APPLICATION AND GENERAL INFORMATION
E-586	2-7/32"	1-9/32"	1-1/2"	Dayton/Batco 01202 Meritor 1779D82 Trailmobile 19172 Standard Forge 204105 GMC 2356111 Dana/Spicer 321427 Trailmobile 38586 Haldex 65470 Wagner 914005 Sirco B586 Haldex C65470 Leland L158 Dana/Spicer M16WJ114	1/4" Oversize Version of E-523.
E-2672	2-17/64"	1-1/2"	1-5/8"	Dayton/Batco 01229 Meritor 1199A3719 Dana/Spicer 321431 Haldex 67366 Wagner 914006 Sirco B922 Leland L1475	For Mack Shoe with 4625B Lining.
E-10823	2-19/64"	1-15/64"	1-1/2"	Meritor 1779X180	For Meritor 14-1/2" x 8" and 10" "W" Series.
E-5089	2-21/64"	1-5/16"	1-5/8"	Dayton/Batco 01204 Meritor 2247X128 Sirco B924 Haldex C63018 Leland L2954	For Mack with Meritor 50,000 lb. Drive Axle.
E-10824	2-41/64"	1-17/64"	1-1/2"	Meritor 1779U593	For Meritor 14-1/2" x 8" and 10" "W" Series Type 1 and Type 3.
E-10838	2-41/64"	1-25/64"	1-1/2"	Meritor 1779L116 Sirco BP109 Leland L430	For Meritor 14-1/2" x 10" "W" Series, Type 2.

ROLLERS - FOR SINGLE WEB BRAKE SHOES

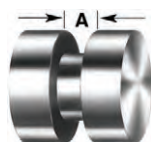

EUCLID NO.	OVERALL LENGTH	"A"	O.D.	REPLACES	APPLICATION AND GENERAL INFORMATION
E-3421A	1-3/8"	3/8"	1-1/4"	Dayton/Batco 01219 Dayton/Batco 01237 Dayton/Batco 01239 Dayton/Batco 01244 Eaton 1005204 Meritor 1199G3725 Navistar 139856R1 Meritor 1779K63 Eaton 2-2110 Dana/Spicer 321463 Dana/Spicer 321464 Dana/Spicer 321465 Trailmobile 383421A Eaton 76734 Wagner 80433 Wagner 914010 Sirco B725 Sirco B872 Haldex C66834 Leland L1691 Leland L2811 Leland L2826 Leland L296 Leland L297 Meritor R517001	For Meritor 15 in. x 3-1/2 in. and 15 in. x 4 in. "T" Brakes and Eaton 15 in. x 4 in. Single Anchor Pin

ROLLERS

"POSI-ROLL" DIAMOND KNURLED ROLLERS

EUCLID NO.	OVERALL LENGTH	O.D.	I.D.	EUCLID PIN NO.	REPLACES	APPLICATION AND GENERAL INFORMATION
E-2217A	23/32"	1-5/8"	15/16"	E-596A	Dayton/Batco 01217K Eaton 039074 Navistar 142917R1 Eaton 2-2108 GMC 2326940 Dana/Spicer 321441 Trailmobile 382217A Haldex 66902 Eaton 76003 Wagner 914012 Sirco B942 Leland L1534 Meritor R517006 Meritor R517006K	Special Alloy Steel to withstand off the road use or severe highway conditions Zinc Yellow Dichromate
E-2217S	23/32"	1-5/8"	15/16"	E-596A	Sirco B942B	Special Alloy Steel to withstand off the road use or severe highway conditions Black Phosphate
E-2111A	1"	1-1/4"	3/4"	E-501	Meritor 1199A625 Dayton/Batco 1205 GMC 2009342 Dana/Spicer 321437 Trailmobile 37825 Trailmobile 382111A Navistar 56102R1 Trailmobile 7-23-3 Leland L1783 Dana/Spicer M10HD100	Heavy-Duty Version of E-2176. Special Alloy Steel to withstand off the road use or severe highway conditions Zinc Yellow Dichromate
E-2176	1"	1-1/4"	3/4"	E-501	Dayton/Batco 01205K Dana/Spicer 11509 Meritor 1199A625 Standard Forge 204100001 Dana/Spicer 321438 Eaton B1220 Haldex C63022 Leland L1716 Dana/Spicer M10HD100	For Cast Shoes. Knurled version of E-500.
E-2214	1"	1-3/8"	3/4"	E-501	Dayton/Batco 01206K Meritor 1199M637 GMC 2095075 Leland L128	1/8" Oversize Version of E-2176
E-2395	1-3/8"	1-1/2"	3/4"	E-2396	Dayton/Batco 01223 Dayton/Batco 01223K Dayton/Batco 01233K Eaton 2-2109 Standard Forge 204108001 Dana/Spicer 321445 Trailmobile 382395 Haldex 66871 Eaton 76369 Sirco B133 Haldex C67490 Leland L1280 Dana/Spicer M10HD101 Meritor R517003	For Dexter, Spicer and Std. Forge 12-1/4" Fabricated Brake Shoes
E-3231	1-3/8"	1-5/8"	3/4"	E-2396	Dayton/Batco 01233 Trailmobile 383231 Haldex C63029 Leland L2943	1/8" Oversize Version of E-2395



ROLLERS

"POSI-ROLL" DIAMOND KNURLED ROLLERS



EUCLID NO.	OVERALL LENGTH	O.D.	I.D.	EUCLID PIN NO.	REPLACES	APPLICATION AND GENERAL INFORMATION
E-3483	1-7/16"	1-1/2"	3/4"	E-3482	Dayton/Batco 01238 Meritor 2297C5021 Meritor 2297E3983 Dana/Spicer 321467 Sirco B135 Haldex C67466 Leland L2352	For Meritor 12-1/4" Dia. "Q" Brake

ROLLERS

EUCLID NO.	OVERALL LENGTH	O.D.	I.D.	EUCLID PIN NO.	REPLACES	APPLICATION AND GENERAL INFORMATION
E-595	23/32"	1-5/8"	15/16"	E-596A	Dayton/Batco 01217 Eaton 039074 Navistar 142917R1 Eaton 2-2108 GMC 2326940 Dana/Spicer 321441 Trailmobile 38595 Haldex 65430 Haldex 65431 Haldex 66902 Trailmobile 700797 Eaton 76003 Wagner 914015 Sirco B052 Haldex C63030 Navistar IT321441 Leland L250 Meritor R517006	For Fabricated Brake Shoes



E-795	23/32"	1-3/4"	15/16"	E-596A	Dayton/Batco 01218 Dana/Spicer 32144118 Trailmobile 38795 Haldex 66647 Wagner 914016 Haldex C66647 Navistar IT321441A Leland L326	1/8 in. Oversize Version of E-595
E-796	23/32"	1-7/8"	15/16"	E-596A	Dana/Spicer 32144114 Haldex 66825 Wagner 914017 Haldex C63032 Leland L327	1/4 in. Oversize Version of E-595

E-500	1"	1-1/4"	3/4"	E-501	Dayton/Batco 01205 Dana/Spicer 11509 Meritor 1199A625 GMC 2009342 Standard Forge 204100001 Fruehauf 219300 Dana/Spicer 321435 Trailmobile 37825 Navistar 56102R1 Haldex 65300 Trailmobile 7-23-3 Trailmobile 700746 Eaton B1220 Sirco B500 Haldex C65300 Leland L100 Dana/Spicer M10HD100	For Cast Shoes
-------	----	--------	------	-------	---	----------------

ROLLERS



EUCLID NO.	OVERALL LENGTH	O.D.	I.D.	EUCLID PIN NO.	REPLACES	APPLICATION AND GENERAL INFORMATION
E-505	1"	1-3/8"	3/4"	E-501	Dayton/Batco 01206 Meritor 1199J3910 Meritor 1199M637 GMC 2095075 Dana/Spicer 321436 Haldex C63026 Navistar IT321436 Leland L128	1/8 in. Oversize Version of E-500
E-504	1"	1-1/2"	3/4"	E-501	Dayton/Batco 01207 Dana/Spicer 10WJ165 Meritor 1199K3911 Meritor 1199Z910 Trailmobile 19161 Standard Forge 204104 GMC 2250099 Haldex 65314 Eaton B1969 Haldex C63027 Leland L124 Dana/Spicer M10WJ165	1/4 in. Oversize Version of E-500
E-9043	1-1/8"	1-1/4"	3/4"	E-9044	Dayton/Batco 01-2056 Dayton/Batco 12056 Eaton 807931 Leland L3018 Meritor R517012	Eaton "ES" Severe Service Cast Shoes
E-2802	1-1/4"	1-5/8"	15/16"	E-2803	Dayton/Batco 01215 Eaton 1003831 Eaton 100831 Eaton 2-3688 Dana/Spicer 321443 Eaton 653087 Sirco B053 Haldex C66608 Leland L1622 Meritor R517016	For Eaton 18 in. x 7 in. Cast Brake Shoes
E-1304 ¹	1-11/32"	1-5/8"	29/32"	E-1305	Dayton/Batco 01222 Dana/Spicer 321461 GMC 3772284 Haldex 66632 Haldex C66632 Wagner FC31970 Leland L428 Meritor R517010	Used on GMC truck rear brakes; Available only in Brake Kit E-2713

ROLLER PINS



EUCLID NO.	O.D.	LENGTH	"A"	REPLACES	APPLICATION AND GENERAL INFORMATION
E-9044	3/4"	2-1/16"		Dayton/Batco 01-2506 Dayton/Batco 12506 Eaton 810390 Leland L3019 Meritor R517013	For Eaton "ES" Severe Service with Cast Shoes

ROLLER PINS



E-501 3/4" 2-1/4"

Dayton/Batco 01250
 Meritor 1246G475
 Meritor 1246S227
 GMC 2009343
 Standard Forge
 205100001
 Dayton/Batco 222069
 Dana/Spicer 321440
 Trailmobile 37096
 Navistar 56103R1
 Haldex 65301
 Trailmobile 7-24-1
 Eaton B1219
 Sirco B499
 Haldex C65301
 Leland L101
 Leland L240
 Dana/Spicer M10SS100

Full Circle Groove for Faster Alignment and Installation. Use with E-2176, E-2111A, E-2214 Rollers



E-2396 3/4" 2-1/4"

Dayton/Batco 01263
 Standard Forge
 205107001
 Eaton 22261
 Dana/Spicer 321446
 Trailmobile 382396
 Haldex 66872
 Haldex 68872
 Sirco B132
 Haldex C67487
 Leland L1281
 Dana/Spicer M10WJ116
 Meritor R517506

Use with E-2395 Roller and E-527 Retainer



E-3482 3/4" 2-13/32"

Dayton/Batco 01271
 Meritor 1246C627
 Meritor 1246F1020
 Dana/Spicer 321468
 Trailmobile 383482
 Sirco B134
 Haldex C67467
 Leland L2353

For Meritor 12-1/4" Dia. "Q" Brake. Use with E-527 Retainer



E-1305 29/32" 2"

Dayton/Batco 01265
 Dana/Spicer 321460
 GMC 3772285
 Haldex C66633
 Wagner FC31971
 Leland L429
 Meritor R517011

Used on GM Truck and Rear Brakes. Use with E-1304 Roller. Available only in Brake Kit E-2713

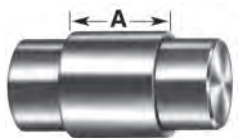

E-596A 59/64" 1-25/32" 23/32"

Dayton/Batco 01262
 Eaton 039075
 Eaton 131520
 Navistar 142918R1
 Eaton 2-2260
 GMC 2326941
 Dana/Spicer 321442
 Trailmobile 38596A
 Haldex 65431
 Trailmobile 700798
 Wagner 914020
 Sirco B152
 Leland L251
 Meritor R517509

For Late Model Eaton Axles. Use with E-2217A Roller. Also used for Cast Shoes

ROLLER PINS

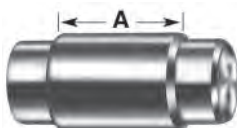

EUCLID NO.	O. D.	LENGTH	"A"	REPLACES
E-2803	59/64"	2-5/32"	1-1/4"	Dayton/Batco 01264
				Eaton 1000382
				Eaton 1003832
				Dana/Spicer 321444
				Sirco B154
				Haldex C66609
				Leland L1623
				Meritor R517017

APPLICATION AND GENERAL INFORMATION

For Eaton 18" x 7" Cast Brake Shoes. Use with E-2802 Roller

BRAKE SHOE WEAR PLATES

Wear Plate Screw Included

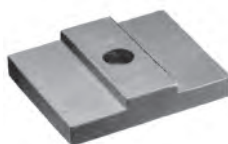





EUCLID NO.	LENGTH	WIDTH	THICKNESS	REPLACES	GENERAL INFORMATION
E-714	1-5/8"	1-1/2"	1/4"	Dayton/Batco 01243	
				Dana/Spicer 341558	
				Leland L304	
				Meritor R547029	
E-947	2-1/16"	1-5/8"	3/8"	Dayton/Batco 01240	Available in Brake Kit E-1812
				Standard Forge 206100001	
				Leland L440	
				Meritor R547015	
				Standard Forge UB3012	

BRAKE SHOE ANCHOR PINS



EUCLID NO.	REPLACES	LENGTH	O. D.	Large - Small	APPLICATION
E-2766S	Dayton/Batco 01434	2-7/32"	1-1/4" - 1"		Meritor "Q" Brake and Spicer "Fast Change" Brake. Zinc Clear Chromate Plated
	Dana/Spicer 15542				
	Trailmobile 382766				
	Haldex 66866				
	Trailmobile 7007140				
	Wagner 914030				
	Sirco B120				
	Navistar IT15542				
	Leland L1416				
	Dana/Spicer M16WJ105				
E-5304	Dayton/Batco 01447	2-1/4"	1"		For Spicer (Dana) 12-1/4" "U" Brake. Use with E-5305 Retainer Clip. Zinc Clear Chromate Plated
	Standard Forge 203113001				
	Haldex 67489				
	Sirco B217				
	Haldex C67489				
	Leland L2368				
	Dana/Spicer M10WJ151				
Meritor R547010					
E-5087	Dayton/Batco 01452	2-11/32"	1-1/4" - 1"		Meritor Mack "Q" Brake. Zinc Clear Chromate Plated
	Meritor 1259V308				
	Sirco B122				
	Haldex C63067				
	Leland L2952				

BRAKE SHOE ANCHOR PINS

EUCLID NO.	REPLACES	LENGTH	O.D.		APPLICATION
			Large	Small	
	Dayton/Batco 01448 Dana/Spicer 15536 Eaton 2-2132 Trailmobile 383711 Haldex 66915 Trailmobile 7007198 Eaton 84769 Wagner 914029 Fruehauf ACF003378001 Holland Hitch ACF33781 Sirco B277 Haldex C66915 Leland L2364 Meritor R537005	2-3/8"	1-1/4" - 1-1/16"		Late Model Fruehauf "XEM" Brake. Zinc Yellow Plated
	E-3711S Dana/Spicer 15536 Sirco B277 Meritor R537005				
	Dayton/Batco 01453 Eaton ACF00266800X Leland L3032 Meritor R547028	2-3/8"	1-1/4" - 1"		Offset to allow use of E-2778 "Q" Brake Shoes with "Pro-Par" Axle Spiders. Black Finish
	Dayton/Batco 01435 Dana/Spicer 15543 Eaton 2-2131 Haldex 66862 Trailmobile 7007191 Eaton 84404 Wagner 914031 Fruehauf ACE009909001 Sirco B377 Haldex C66862 Navistar IT15543 Leland L1496 Meritor R537004	2-3/8"	1-1/4"		Early Model Fruehauf "XEM" Brake. Zinc Clear Chromate Plated
	Dayton/Batco 01400 Dayton/Batco 01442 Trailmobile 11882 Meritor 1259N170 Dana/Spicer 15529 Standard Forge 203106 Eaton 22126 Fruehauf 578322 Haldex 65344 Haldex 65440 Trailmobile 7-12-32 Trailmobile 7007159 Wagner 914026 Sirco B832 Haldex C65344 Leland L238 Dana/Spicer M10WJ164	2-15/32"	1-1/4"		Zinc clear chromate plated. For Meritor and Fruehauf Pro-Par axle with fabricated shoes..
	Dayton/Batco 01420 Dana/Spicer 15541 GMC 3772283 Haldex 67368 Haldex C67368 Wagner FC31983 Leland L1683 Meritor R547023	2-9/16"	1-1/4"		For GM trucks and others with 15" x 6" and 15" x 7" Wagner Air Brakes. Use E-801 Snap Ring. Zinc Clear Chromate Plated

BRAKE SHOE ANCHOR PINS

EUCLID NO.	REPLACES	LENGTH	O.D.	Large - Small	APPLICATION
E-2390	Dayton/Batco 01417	2-3/4"	1"		For Late Model Std. Forge Fabricated Shoes. 12-1/4" Dia. Brakes with Weld-on Spider. Use with E-2391 Washer and E-2392 Snap Ring. Hard Chrome Plated
	Dana/Spicer 15537				
	Eaton 2-2129				
	Standard Forge 203108				
	Standard Forge 203112001				
	Trailmobile 382390				
	Haldex 66683				
	Eaton 83674				
	Sirco B216				
	Haldex C67473				
	Leland L1368				
	Leland L1585				
Dana/Spicer M10WJ108					
Meritor R537001					







E-1112A	Dayton/Batco 01401	2-3/4"	1-1/4"		For Meritor, Eaton, Fruehauf, Spicer and Std. Forge Axles. Use with E-801 Snap Ring and E-1113 Retainer Washer. Zinc Clear Chromate Plated
	Dayton/Batco 01443				
	Meritor 1259J218				
	Meritor 1259R200				
	Trailmobile 15276				
	Dana/Spicer 15527				
	Eaton 2-2127				
	Standard Forge 203109				
	Trailmobile 381112				
	Haldex 65369				
	Trailmobile 70017258				
	Dayton/Batco 771394				
	Eaton 820196				
	Eaton 82943				
	Wagner 914027				
Eaton B2076					
Sirco B887					
Haldex C65369					
Navistar IT15527					
Leland L788					
Dana/Spicer M10HP102					
Dana/Spicer M10HP104					











E-512	Dayton/Batco 01402	2-7/8"	1-1/4"		For Meritor and Fruehauf Fabricated Shoes. Hard Chrome Plated
	Dayton/Batco 01440				
	Dayton/Batco 01441				
	Dana/Spicer 11093				
	Meritor 1259P1134				
	Meritor 1259Q251				
	Meritor 1259T280				
	Navistar 126403R1				
	Navistar 141063R1				
	Dana/Spicer 15525				
	Meritor 1759M13				
	Eaton 2-2128				
	Standard Forge 203102001				
	GMC 2295423				
	Fruehauf 330673				
	Trailmobile 38512				
	Trailmobile 46946				
	Navistar 472958C1				
Haldex 65328					
Haldex 65439					
Trailmobile 7-12-28, 700753					
Eaton 83308					
Sirco B251					
Haldex C66910					
Leland L152 ,L321					
Dana/Spicer M10WJ162					

BRAKE SHOE ANCHOR PINS

EUCLID NO.	REPLACES	LENGTH	O.D.	O.D.		APPLICATION
				Large	Small	
	E-512S Meritor 1259Q251 Dayton/Batco 1440 Dana/Spicer 15525 Wagner 914023 Sirco B251	2-7/8"	1-1/4"			For Meritor and Fruehauf Fabricated Shoes. Zinc Clear Plated
	E-10835 Meritor 1259L194 Sirco BP110	3-7/16"	1-1/4"			For "W" Series with Lube Holes.
	E-9041 Dayton/Batco 01-4244 Dayton/Batco 14244 Eaton 810316 Leland L3023 Meritor R547024	3-9/16"	1-1/4"			For Eaton "ES" Severe Service with Cast Shoes. Black Finish
	E-2119 Dayton/Batco 01404 Dayton/Batco 01406 Dayton/Batco 01424 Meritor 1259K219 Meritor 1259N1132 Meritor 1259S201 Dana/Spicer 15532 Trailmobile 382119 Navistar 474546C1 Eaton B2023 Leland L1784 Meritor MPS2663	3-19/32"	1-1/4"			Use with Cast Shoes or Fabricated Shoes with replaceable Bushings. Zinc Clear Chromate Plated
	E-502 Dayton/Batco 01404 Dayton/Batco 01424 Dana/Spicer 11090 Meritor 1259L90 Meritor 1259N1132 Meritor 1259R252 Meritor 1259R252BK Meritor 1259R252BULK Meritor 1259U281 Dana/Spicer 15532 Standard Forge 203100001 Fruehauf 219162 Trailmobile 37084 Trailmobile 38502 Navistar 474546C1 Navistar 56104R1 Haldex 65307 Trailmobile 7-12-1 Trailmobile 700725 Eaton 820012 Wagner 914024 Eaton B1223 Sirco B311 Haldex C65307 Leland L113 Dana/Spicer M10WJ159	3-3/4"	1-1/4"			For Cast and Fabricated shoes with replaceable bushings. Also Late Model Mack. Hard Chrome Plated

BRAKE SHOE ANCHOR PINS

EUCLID NO.	REPLACES	LENGTH	O.D.	O.D. Large - Small	APPLICATION
	Dayton/Batco 01405 Dana/Spicer 11007 Meritor 1259G163 Meritor 1259R252 Meritor 1259U281 Dana/Spicer 15531 Trailmobile 19170 Standard Forge 203100002 Haldex 65308 Wagner 914025 Eaton B12232 Leland L114 Dana/Spicer M10WJ160	3-3/4"	1-1/4"		Same as E-502 Pin except drilled for lubrication. Zinc Clear Chromate Plated
	Meritor 1259X76 Sirco BP104 Leland L103	4-3/8"	1-1/4"		For "W" Series with Lube Holes.
	Dayton/Batco 01432 Dana/Spicer 15540 Eaton 820092 Eaton B1705 Sirco B424 Haldex C66649 Leland L1209 Meritor R537003	5-1/16"	1-1/2"		For Eaton 12-1/4" x 5-1/2" and 12-1/4" x 7-1/2" Single Anchor Pin Brake. Use with E-526 Lock Ring and E-580 Retainer. Available in Brake Kit E-2126. Black Finish
	Dayton/Batco 01421 Dana/Spicer 15560 Haldex 65421 Leland L182X Meritor R547030	5-13/16"	1-1/4"		For Mack Trucks Use with E-5093 Lock Ring. Available only in Brake Kit E-2676. Zinc Clear Chromate Plated
	Meritor 1259W205	5-7/8"	1-1/4"		For "W" Series with Lube Holes.
	Dayton/Batco 01431 Dana/Spicer 15538 Standard Forge 203105003 Standard Forge 203205003 Trailmobile 382029 Haldex C66751 Leland L728 Dana/Spicer M10HP103 Meritor R537006	6-9/32"	1"		For Spicer 12-1/4" Dia. Brakes. Zinc Clear Chromate Plated
	Dayton/Batco 01408 Leland L445 Meritor R547013 Standard Forge UB2304 Standard Forge UB30031	6-31/64"	1"		Zinc clear chromate plated eccentric type. For Standard Forge 12-1/4" brake with wear plates and flat head camshafts..
	Meritor 1259P198	6-7/8"	1-1/4"		For "W" Series with Lube Holes.

*Not Sold Separately

BRAKE SHOE ANCHOR PINS



EUCLID NO.	REPLACES	LENGTH	O.D.	"A"	HEAD DIA.	APPLICATION
E-3870	Dayton/Batco 01451	2-11/16"	13/16"		1-1/4"	For Meritor 15" x 4" Front "Q" Brake. Black Finish
	Meritor 1259X1012					
	Sirco B950					
	Haldex C69611					
	Leland L2930					

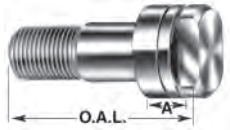

E-3424	Dayton/Batco 01437	2-3/4"	13/16"	17/32"	1-1/4"	For Meritor "T" Series 15" x 3-1/2" and 15" x 4" Type 1 and 2 Brakes. Available in Brake Kit E-4691. Zinc Clear Chromate Plated
	Meritor 1259B262					
	Dana/Spicer 15550					
	Navistar 482438C1					
	Haldex 66841					
	Wagner 914032					
	Haldex C66841					
Leland L1736						
Leland L754						

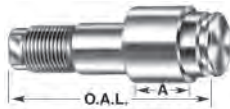

E-3445	Dayton/Batco 01430	3-5/16"	13/16"	7/8"		Eccentric Pin. For Meritor "T" Series 16-1/4" x 3-1/2" Brake. Zinc Clear Chromate Plated
	Navistar 142739R1					
	Dana/Spicer 15554					
	Meritor 1759Z26					
Haldex C63073						

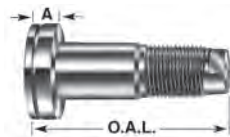

E-2798	Dayton/Batco 01446	3-5/16"	1-3/16"	1/2"	1-3/8"	For 15" x 4" with Wagner Brakes. Use with E-4961A Nut and E-2723 Snap Ring. Available only in Brake Kit E-3291. Zinc Clear Chromate Plated
	Dana/Spicer 15557					
	Wagner 80414					
	Sirco B898					
	Haldex C66879					
	Wagner F80414					
Leland L1675						
Meritor R547022						

BRAKE HARDWARE

For Brake Anchor Pins, Rollers and Roller Pins



EUCLID NO.	O.D.	I.D.	THICK	DIM. BETWEEN LEG OPENING	HEIGHT	REPLACES	APPLICATION AND GENERAL INFORMATION
E-1106				5/8"	1-11/32"	Dayton/Batco 01493	Anchor Pin Lock Washer for Std. Forge 12-1/4" Dia. Trailer Brakes and Meritor 16-1/4" "T" Series Steering Axle Brake
						Dana/Spicer 11527	
						Meritor 1229M221	
						Dana/Spicer 341535	
						Standard Forge 403104	
						Haldex 65561	
						Haldex 66544	
						Haldex C65561	
						Leland L1755	
						Leland L455	
Dana/Spicer M10HN154							



E-671	1-11/16"	1-1/4"	17/32"			Dayton/Batco 01471	Anchor Pin Felt Retainer for use with E-521 and E-608 Anchor Pins. Available in Brake Kit E-2676
						Dana/Spicer 351578	
						Haldex 65425	
						Leland L334	
						Eaton M1561	
Meritor R547032							

BRAKE HARDWARE

For Brake Anchor Pins, Rollers and Roller Pins



EUCLID NO.	O.D.	I.D.	THICK	DIM. BETWEEN LEG OPENING	HEIGHT	REPLACES	APPLICATION AND GENERAL INFORMATION
E-563	1-3/4"	1-1/4"	1/8"			Dayton/Batco 01470 Dana/Spicer 11005 Meritor 1205K193 Fruehauf 219296 Dana/Spicer 351577 Trailmobile 37090 Gunite 4010 Standard Forge 403101 Navistar 56107R1 Haldex 65304 Trailmobile 7-18-1 Trailmobile 700758 Wagner 914049 Sirco B011 Eaton B1211 Haldex C63102 Navistar IT351577 Leland L110 Dana/Spicer M10HN153 Leland W451	Anchor Pin Felt Retainer for use with E-537 Felt



EUCLID NO.	O.D.	I.D.	THICK	REPLACES	APPLICATION AND GENERAL INFORMATION
E-537	1-5/8"	1-1/4"	5/32"	Dayton/Batco 01460 Dana/Spicer 11004 Fruehauf 219295 Dana/Spicer 351576 Dana/Spicer 351579 Trailmobile 37462 Gunite 4009 Standard Forge 409100 Navistar 56106R1 Meritor 5X180 Meritor 5X640 Haldex 65303 Haldex 65424 Trailmobile 7-25-2 Trailmobile 700756 Eaton 821233 Wagner 914050 Sirco B901 Haldex C63101 Navistar IT351576 Leland L109 Leland L333 Dana/Spicer M10HR119 Eaton X6562	Anchor Pin Felt. Use with E-563 Retainer



EUCLID NO.	O.D.	I.D.	THICK	REPLACES	APPLICATION AND GENERAL INFORMATION
E-1426	1-5/8"	1-1/4"	9/64"	Dana/Spicer 11004 Fruehauf 219295 Standard Forge 409100 Navistar 56106R1 Haldex 67365 Eaton 821233 Sirco B501 Haldex C63103 Dana/Spicer M10HR119 Meritor R547033 Eaton X6562	Neoprene Anchor Pin Seal. Alternate for E-537 Felt

BRAKE HARDWARE

For Brake Anchor Pins, Rollers and Roller Pins



EUCLID NO.	O.D.	I.D.	THICK	REPLACES	APPLICATION AND GENERAL INFORMATION
E-1269	1-3/4"	1-1/4"	9/64"	Dayton/Batco 01462	Neoprene Anchor Pin Seal. Alternate for E-537 Felt and E-563 Retainer
				Dayton/Batco 01463	
				Dana/Spicer 11004	
				Eaton 2-2133	
				Fruehauf 219295	
				Dana/Spicer 351582	
				Standard Forge 409100	
				Navistar 56106R1	
				Haldex 65302	
				Trailmobile 700660	
				Trailmobile 700760	
				Eaton 821233	
				Sirco 8501	
				Eaton 85135	
				Wagner 914052	
				Meritor A1205S1943	
				Sirco B501	
				Haldex C65302	
				Wagner FC031960	
				Navistar IT351582	
Leland L105					
Dana/Spicer M10HR119					
Eaton X6562					



EUCLID NO.	I.D.	THICK	REPLACES	APPLICATION AND GENERAL INFORMATION
E-527	3/4"		Dayton/Batco 01301	Lock Ring for use with Eaton 16-1/2" Dia. Fabricated Steel Shoes and Std. Forge 12- 1/4" Fabricated Steel Shoes
			Meritor 1229M1105	
			Meritor 1229T3166	
			Navistar 138808R2	
			Eaton 2-2136	
			Standard Forge 214102	
			Fruehauf 253395	
			Dana/Spicer 341526	
			Trailmobile 38527	
			Haldex 65311	
			Eaton 820063	
			Eaton 86230	
			Eaton B1661	
			Sirco B379	
			Haldex C65311	
Eaton E1661				
Leland L118				
Dana/Spicer M10HR102				

E-2392	15/16"		Dayton/Batco 01489	Lock Ring for use with E-2390 Pin
			Eaton 2-2138	
			Standard Forge 214107	
			Dana/Spicer 341527	
			Haldex 66870	
			Eaton 86961	
			Sirco B380	
			Haldex C67475	
Leland L1370				
Dana/Spicer M10HR104				
Meritor R547004				

BRAKE HARDWARE

For Brake Anchor Pins, Rollers and Roller Pins



EUCLID NO.	I.D.	THICK	REPLACES	APPLICATION AND GENERAL INFORMATION
E-801	1-1/8"		Dayton/Batco 01482 Meritor 1229X1116 Eaton 2-2137 Standard Forge 214100 Eaton 2807929 Dana/Spicer 31624 Navistar 3212934R Dana/Spicer 341525 Trailmobile 38801 Haldex 65358 Trailmobile 700728 Eaton 820007 Eaton 86596 Wagner 914040 Eaton B1214 Sirco B793 Haldex C65358 Wagner FC031961 Navistar IT341525 Leland L397	Lock Ring. For Meritor 4000-6000 Series Axles. Also used on 1-1/4" Anchor Pins with grooves.



E-10834	1-1/8"		Meritor 1218Z52 Sirco BP107	Lock Ring
----------------	--------	--	--------------------------------	-----------







E-2723	1-1/4"		Dayton/Batco 01499 Dana/Spicer 341550 Trailmobile 382723 Haldex 66894 Sirco B823 Haldex C66894 Wagner F31926 Wagner FC031926 Leland L1670 Meritor R547019	Lock Ring
---------------	--------	--	--	-----------



EUCLID NO.	O.D.	I.D.	LENGTH	THICK	REPLACES	APPLICATION AND GENERAL INFORMATION
E-538	1-1/4"	1"	1-3/4"	5/64"	Dayton/Batco 01480 Dana/Spicer 11006 Meritor 1218L90 Meritor 1218M43 Standard Forge 214106 Fruehauf 219156 Dana/Spicer 341528 Navistar 56108R1 GMC 652443 Haldex 65305 Trailmobile 7333 Eaton 820007 Sirco B111 Eaton B1214 Haldex C-65305 Leland L111 Dana/Spicer M10HR123	Anchor Pin Lock Ring used with E-512, E-502 and E-503 Anchor Pins machined with round grooves only.

BRAKE HARDWARE

For Brake Anchor Pins, Rollers and Roller Pins

	EUCLID NO.	OVERALL LENGTH	HOLE CTR. TO HOLE CTR.	HOLE DIA.	THICK	REPLACES	APPLICATION AND GENERAL INFORMATION
	E-2401	3-1/2"	1-15/16"		3/16"	Dayton/Batco 01488 Dana/Spicer 341544 Standard Forge 999197 Haldex C63097 Leland L1278 Dana/Spicer M10HR105 Meritor R547001	Anchor Pin Link for Early Model Std. Forge 12-1/4" Dia. Trailer Brakes with New Style Fabricated Steel Shoe
	E-3871	4"	2-5/16"	15/16"		Dayton/Batco 01478 Meritor 2205P1004 Dana/Spicer 341561 Sirco B951 Haldex C69612 Leland L2934	Anchor Pin Link for 15" x 4" "Q" Brakes
	E-10829	4-3/4"	2-1/2"	3/4"		Meritor 1245E161 Meritor 1245E164	Anchor Pin Retainer Plate for Meritor "W" Series 14-1/2" x 10" Coach Brakes
	E-10819	4-3/4"	2-1/2"	1-1/4"		Meritor 1245N144	Anchor Pin Link



	EUCLID NO.	THREAD	HEX	HIGH	REPLACES	APPLICATION AND GENERAL INFORMATION
	E-1107	3/4"-16	1-1/8"	27/64"	Dayton/Batco 01497 Dana/Spicer 12052, 5003718, 341536 Trailmobile 3-23-2, 3-23-3 Trailmobile 37338, 37703, 50BZF23C Standard Forge 402101 Haldex C66752 Leland L509, SA1818 Meritor R301107, R547006	Jam nut. Use with E-1814, E-2029 or E-2414 Anchor Pins

GRADE C



	E-4961A	3/4"-16	1-1/8"	5/8"	Sirco 073, 806 Dayton/Batco 01476, 093372, 095659, 133011, 136563, SLN105, 2311480144 Gunitite 21137 Navistar 3383857 Dana/Spicer 341551, 511020 Trailmobile 384961A, 5034A7 Haldex 66888, 67265 Navistar 878179R1 Leland L1752, L2121, L2946, W110, W451, W99, SA1162 Fruehauf MWCX01068 Meritor N1121, NL1121, R004961A NWRA X1068	Lock Nut for Meritor 15" x 3-1/2" and 4" T Series Brakes.
--	---------	---------	--------	------	---	---

BRAKE HARDWARE

For Brake Anchor Pins, Rollers and Roller Pins



EUCLID NO.	THREAD	HEX	HIGH	REPLACES	APPLICATION AND GENERAL INFORMATION
E-937	1"-14	1-7/16"	7/8"	Dayton/Batco 092253	Lock Nut for use with E-1403 Anchor Pin and E-3975 Lockwasher
				Dayton/Batco 102635	
				Trailmobile 15193	
				Trailmobile 16857	
				Trailmobile 22T5495	
				Dayton/Batco 334206	
				Dana/Spicer 341545	
				Trailmobile 38937	
				Eaton 44672E	
				Haldex 66547	
				Trailmobile 7007107	
				Eaton 821616	
				Sirco B429	
				Haldex C66651	
				Fruehauf FSP00602009	
				Fruehauf FSP00602PK9	
				Leland L421	
				Leland L811	
				Fruehauf MHS010562	
				Fruehauf MRM0T5495	
Fruehauf MRMT5495D					
Fruehauf MRMT5495S					
Meritor R30937					
Meritor R587001					
Leland SA1218					
Sirco SR1011					



EUCLID NO.	REPLACES	APPLICATION AND GENERAL INFORMATION
E-1581	Dayton/Batco 01310	Roller Retainer for "Pro-Par" Axle with 12-1/4" Brakes
	Dana/Spicer 341531	
	Fruehauf ACD002233001	
	Fruehauf ACD22331	
	Sirco B868	
	Haldex C67448	
	Navistar IT341531	
	Leland L1697	
Meritor R527001		



E-3007A	Dayton/Batco 01313	Roller Retainer for Meritor "Q" and Q Plus™ Brakes
	Eaton 2-2113	
	Eaton 2808058	
	Meritor 3105B210	
	Meritor 3105L194	
	Meritor 3105R200	
	Dana/Spicer 341532	
	Trailmobile 383007A	
	Haldex 66903	
	Trailmobile 7007147	
	Trailmobile 7007207	
	Eaton 77830	
	Wagner 914045	
	Sirco B161	
Sirco B161B		
Navistar IT341532		
Leland L1537		

BRAKE HARDWARE

For Brake Anchor Pins, Rollers and Roller Pins



EUCLID NO.	REPLACES	APPLICATION AND GENERAL INFORMATION
E-3227	Dayton/Batco 01311 Eaton 2-2112 Eaton 2808058 Dana/Spicer 341530 Trailmobile 383227 Haldex 65376 Trailmobile 7007190 Eaton 77464 Wagner 914047 Fruehauf ACF001328001 Fruehauf ACF13281 Sirco B498 Haldex C65376 Navistar IT341530 Leland L894 Meritor R527002	Roller Retainer for all "Pro-Par" Axles with 16-1/2" Brakes including "XEM"



E-539	Dayton/Batco 01300 Dana/Spicer 11229 Navistar 126402R1 Meritor 1718Y103 Eaton 2-2111 Standard Forge 214103 Fruehauf 330734 Dana/Spicer 341529 Trailmobile 38539 Trailmobile 39647 Haldex 65327 Trailmobile 7-18-8 Trailmobile 700719 Eaton 77099 Wagner 914044 Sirco B151 Haldex C65327 Navistar IT341529 Leland L151 Dana/Spicer M16WJ103	Roller Retainer for use with E-523, E-586, E-598, E-781, E-2177, E-2215 Rollers
-------	---	---



E-5478	Dayton/Batco 01294 Meritor 1718Y103 Eaton 2808058 Dana/Spicer 341570 Trailmobile 385478 Sirco B431 Haldex C63001 Leland L2961	Brake Shoe Roller Retainer for Eaton 16-1/2" "ES" Brake
--------	--	---



EUCLID NO.	CLIP OPENING	REPLACES	APPLICATION AND GENERAL INFORMATION
E-5124	63/64"	Dayton/Batco 01393 Eaton 1006500 Haldex C63007 Leland L2828	Shoe Hold Down Spring for Eaton 15" x 4" front brakes with 1-1/2" offset spider
E-5125	1-7/16"	Dayton/Batco 01394 Eaton 1006534 Haldex C63006 Leland L2827	Shoe Hold Down Spring for Eaton 15" x 4" front brakes with 2" offset spider



EUCLID NO.	O.D.	LENGTH	REPLACES	APPLICATION AND GENERAL INFORMATION
E-9045	3/16"	1-1/4"	Dayton/Batco 01303 Eaton 810530 Leland L3021 Meritor R517014	Roll Pin Lock for use with E-9044 Roller Pin

BRAKE HARDWARE

For Brake Anchor Pins, Rollers and Roller Pins



EUCLID NO.	LENGTH	REPLACES	APPLICATION AND GENERAL INFORMATION
E-4078	1-1/16"	Dayton/Batco 18H01456 Eaton 804286 Wagner F17814 Bendix H1456 Leland K165 Meritor R404078 Meritor R40H1456	Rubber Dust Cover for Eaton 15" x 4" Front Brakes



EUCLID NO.	THREAD	LENGTH	REPLACES	APPLICATION AND GENERAL INFORMATION
E-773	1/4"-20	1/4"	Dayton/Batco 01302 Fruehauf 102570 Meritor 1199B626 Dana/Spicer 12200 Dana/Spicer 341540 Standard Forge 400101 Dana/Spicer 5005395 Haldex 65325 Trailmobile 7342 Trailmobile 7344 Eaton B1217 Haldex C66755 Leland L145 Meritor S843	Roller Pin Set Screw



E-9042	5/16"-24	5/8"	Dayton/Batco 01-4903 Dayton/Batco 14903 Eaton 810392 Haldex C63091 Leland L3025 Meritor R547025	Anchor Pin Lock Screw for use with E-9041 and E-9050 Anchor Pins
--------	----------	------	--	--









E-579A	3/8"-16	5/16"	Dayton/Batco 01490 Eaton 2-2139 Fruehauf 219297 Fruehauf 254253 Dana/Spicer 341539 Trailmobile 38579A Standard Forge 400103 Gunite 4011 Navistar 56105R1 Haldex 65331 Trailmobile 7781 Eaton 87326 Eaton B1213 Sirco B861 Haldex C65331 Leland L168 Dana/Spicer M10HM130 Meritor S265D	Anchor Pin Lock Screw used on Both Tractor and Trailer Spiders to Lock Anchor Pin in place
--------	---------	-------	---	--



EUCLID NO.	O.D.	I.D.	THICK	REPLACES	APPLICATION AND GENERAL INFORMATION
E-2725				Dayton/Batco 01392 Dana/Spicer 19893 Trailmobile 382725 Sirco B825 Sirco B829 Haldex C66896 Wagner FC015915 Leland L1673 Meritor R547020	Spring Washer for Wagner 15" x 3", 3-1/2" and 4" Diameter Air Brake

BRAKE HARDWARE

For Brake Anchor Pins, Rollers and Roller Pins

	EUCLID NO.	O.D.	I.D.	THICK	REPLACES	APPLICATION AND GENERAL INFORMATION
	E-2726				Dayton/Batco 01392 Dana/Spicer 19894 Trailmobile 382726 Haldex 67369 Sirco B826 Sirco B829 Haldex C67369 Wagner FC004395 Leland L1674 Meritor R402726 Meritor R40FC004395 Meritor R547021	"C" Washer for Wagner 15" x 3", 3-1/2" and 4" Diameter Air Brake
	E-10816*		5/16"			Lock Washer. Medium Tension
	E-3975		1"		Dayton/Batco 01497 Navistar 131048 Trailmobile 221425001 Dana/Spicer 341546 Trailmobile 383975 Eaton 821231 Haldex C66654 Fruehauf MRM014250001 Fruehauf MRM01425001D Fruehauf MRM01425001S Meritor R303975 Leland SA1464 Sirco SR1005 Eaton X4212	Lock Washer for use with E-1403 Anchor Pin
	E-2724	13/16"	1/4"	1/16"	Dayton/Batco 01392 Meritor 1829P198 Dana/Spicer 19892 Trailmobile 382724 Sirco B824 Sirco B829 Haldex C66895 Wagner F18788 Wagner FC018788 Leland L1671 Leland L1674	Guide Washer for Wagner 15" x 3", 3-1/2" and 4" Diameter Air Brake
	E-10817	1-47/64" x 1"	11/32"	3/16"	Meritor 1229D108	Anchor Pin Lock for Meritor "W" Series 14-1/2" x 4" and 6" Coach Brakes
	E-10865	1-1/4"	3/4"	3/64"	Bendix 55656	Use on Meritor 14-1/2" x 10" W series coach brakes and 15" x 3-1/2" and 4" T brakes.
	E-3874	1-1/4"	13/16"	5/32"	Dayton/Batco 01477 Meritor 1229V1504 Dana/Spicer 341562 Sirco B954 Haldex C66843 Leland L2933	Anchor Pin Washer for Meritor 15" x 4" Front "Q" Brake

*Not Sold Separately

BRAKE HARDWARE - For Brake Anchor Pins, Rollers and Roller Pins

EUCLID NO.	O.D.	I.D.	THICK	REPLACES	APPLICATION AND GENERAL INFORMATION
E-3427	1-3/8"	25/32"	1/8"	Dayton/Batco 01475 Meritor 1229V1556 Navistar 13611VA Dana/Spicer 341552 Sirco B556 Haldex C66847 Leland L1751	Anchor Pin Washer for Meritor 15" x 3-1/2" and 4" "T" Series Brakes
				Dayton/Batco 01473 Eaton 22135 Dana/Spicer 351581 Standard Forge 403147 Haldex 66869 Sirco B392 Haldex C67474 Navistar IT351581 Leland L1369 Dana/Spicer M10HM136 Dana/Spicer M10HN136 Meritor R547003	
E-2391	1-1/2"	1"	1/32"	Dayton/Batco 01472 Dayton/Batco 04309 Eaton 102330 Meritor 1229B1848 Meritor 1229G2971 Meritor 1229Q433 Trailmobile 15408 Eaton 3-2180 Dana/Spicer 351580 Trailmobile 381113 Haldex 65373 Trailmobile 700729 Eaton 820182 Wagner 914054 Eaton B2019 Sirco B988 Haldex C65373 Navistar IT351580 Leland L889	Anchor Pin Washer for use with E-2390 Anchor Pin
E-10842	1-5/8"	29/32"	1/4"	Meritor 1229T1554	Anchor Pin Washer
E-1113	1-7/8"	1-17/64"	1/16"	Dayton/Batco 01472 Dayton/Batco 04309 Eaton 102330 Meritor 1229B1848 Meritor 1229G2971 Meritor 1229Q433 Trailmobile 15408 Eaton 3-2180 Dana/Spicer 351580 Trailmobile 381113 Haldex 65373 Trailmobile 700729 Eaton 820182 Wagner 914054 Eaton B2019 Sirco B988 Haldex C65373 Navistar IT351580 Leland L889	Anchor Pin Washer for Meritor 4000-6000 Series Axle Spline End
				Meritor 1229T1554	
E-10831	1-7/8"	1-17/64"	3/32"	Meritor 1229E1565	Anchor Pin Washer
E-10832	1-7/8"	1-17/64"	1/8"	Meritor 1229F1566	Anchor Pin Washer
E-10833	1-7/8"	1-17/64"	5/32"	Meritor 1229G1567	Anchor Pin Washer







BRAKE SHOE BUSHINGS

EUCLID NO.	O.D.	I.D.	LENGTH	REPLACES	APPLICATION AND GENERAL INFORMATION
E-1808	1-1/16"	1"	1-3/4"	Dayton/Batco 01503 Dana/Spicer 11508 Dana/Spicer 231027 Standard Forge 4500 Wagner 914061 Leland L425 Dana/Spicer M10WJ102 Meritor R547007 Standard Forge UB2212 Standard Forge UB4500	Stainless steel version of E-1026 bushing



BRAKE SHOE BUSHINGS

EUCLID NO.	O.D.	I.D.	LENGTH	REPLACES	APPLICATION AND GENERAL INFORMATION	
E-2218	1-3/8"	1-1/4"	11/16"	Dayton/Batco 01509 Meritor 1225F266 Dayton/Batco 1500 Fruehauf 219299 Standard Forge 405101 Navistar 56098R1 Eaton B1559 Eaton B1713 Sirco B211S Eaton B6154	Stainless steel version of E-541 bushing	
	E-541	1-3/8"	1-1/4"	11/16"	Dayton/Batco 01500 Meritor 1225F266 Dayton/Batco 1509 Fruehauf 219299 Dana/Spicer 231026 Trailmobile 37824 Standard Forge 405101 Navistar 56098R1 Haldex 65306 Trailmobile 7-22-3 Trailmobile 700727 Eaton B1559 Eaton B1599 Eaton B1713 Sirco B211 Eaton B6154 Haldex C65306 Eaton E1559 Eaton E1599 Leland L112 Dana/Spicer M16HD102	Steel-backed bronze for cast shoe or rebushable fabricated shoes.
	E-530	1-3/8"	1-1/4"	1-1/4"	Dayton/Batco 01510 Dana/Spicer 231029 Standard Forge 405102 Haldex 65422 Eaton B17131 Haldex C63083 Leland L183 Dana/Spicer M16HD102 Meritor R570005	Graphite impregnated. For 16-1/2" and 17-1/4" x 10" Brakes. Use with E-1431 anchor pin.
	E-9047	1-13/32"	1-1/4"	3/4"	Dayton/Batco 01-5002 Dayton/Batco 15002 Eaton 809068 Leland L3024 Meritor R570004	Steel. For Eaton "ES" Severe Service cast brake shoes.
	E-10839	1-1/2"	1-1/4"	5/8"	Meritor 1725H8	Use with Meritor coach 14-1/2" brake
	E-10813	1-1/2"	1-1/4"	1-61/64"	Meritor 1725V22	Use with Meritor coach 14-1/2" brake.

GREASE FITTINGS



EUCLID NO.	THREAD	REPLACES	APPLICATION AND GENERAL INFORMATION
E-1307	1/8" Pipe Thread	Dayton/Batco 334475 Dana/Spicer 341541 Sirco B8662 Leland L1212 Meritor R301307 Leland SA1257	Straight fitting. For Anchor Pins, Support Brackets and Spiders



E-1308	1/8" Pipe Thread	Dana/Spicer 341542 Sirco B8663 Leland L2100	45° angle fitting. For Anchor Pins, Support Brackets and Spiders
--------	------------------	---	--

ANCHOR PIN SPIDER BUSHINGS



EUCLID NO.	O.D.	I.D.	LENGTH	REPLACES	APPLICATION AND GENERAL INFORMATION
E-2389	1-1/8"	1"		Dayton/Batco 02235 Dayton/Batco 1318 Dana/Spicer 16564 Eaton 22143 Standard Forge 405131 Haldex 66873 Sirco B362 Haldex C67476 Leland L1373 Dana/Spicer M10WJ138 Dana/Spicer M10WJ183 Meritor R557001 Meritor R577001	For Late Model Std. Forge 12-1/4" Brakes



E-8938	1-3/8"	1-1/4"	1-29/64"	Meritor 1225B496 Sirco B888D	Stainless steel "dimpled" I.D. Available exclusively from Euclid! Same as E-1893, except dimpled I.D. surface acts as reservoir to trap and hold antiseize lubricant corrosion resistance. Makes anchor pin removal easier at reline.
--------	--------	--------	----------	---------------------------------	---



E-1893	1-3/8"	1-1/4"	1-29/64"	Dayton/Batco 02219 Trailmobile 12241 Meritor 1225B496 Trailmobile 15409 Dana/Spicer 16563 Dana/Spicer 16565 Eaton 2-2142 Trailmobile 21L1498 Eaton 2809506 Haldex 65372 Haldex 65732 Trailmobile 7-6-33 Trailmobile 7007197 Eaton 88422 Sirco B888S Haldex C63084 Leland L888	Stainless steel. Smooth I.D. No slot. Use with E-1112 pin
--------	--------	--------	----------	---	---



E-1893S	1-3/8"	1-1/4"	1-29/64"	Dana/Spicer 16565 Wagner 914065 Sirco B888 Haldex C65372 Leland L888 Meritor R547008	Carbon steel. Smooth I.D. No slot. Use with E-1112 pin
---------	--------	--------	----------	---	--

ANCHOR PIN SPIDER BUSHINGS



EUCLID NO.	O.D.	I.D.	LENGTH	REPLACES	APPLICATION AND GENERAL INFORMATION
E-919	1-3/8"	1-1/4"	1-15/32"	Dayton/Batco 02217 Meritor 1225G449 Dana/Spicer 16562 Trailmobile 38919 Haldex 65448 Trailmobile 7001622 Wagner 914064 Sirco B595 Sirco B595S Haldex C65448 Leland L595	Stainless Steel. Slot on center. Use with E-502 and E-512 pins



E-920	1-3/8"	1-1/4"	1-15/32"	Dayton/Batco 02216 Meritor 1225A443 Meritor 1225S1267 Meritor 1225U827 Dana/Spicer 16561 Eaton 2-2141 Eaton 2809507 Haldex 65366 Trailmobile 7001621 Trailmobile 700726 Eaton 88057 Navistar 966197R1 Fruehauf AXA000068 Holland Hitch AXA0068 Holland Hitch AXA0068X Sirco B495 Sirco B495S Haldex C65366 Navistar IT16561 Leland L594	Stainless steel. Slot off center. Use with E-609 pin
E-920S	1-3/8"	1-1/4"	1-15/32"	Meritor 1225U827 Dana/Spicer 16561 Wagner 914063 Sirco B495	Carbon steel. Slot off center. Use with E-609 pin



E-10836	1-1/2"	1-1/4"	1-15/32"	Meritor 1225X440 Sirco BP108 Leland L566
----------------	--------	--------	----------	--

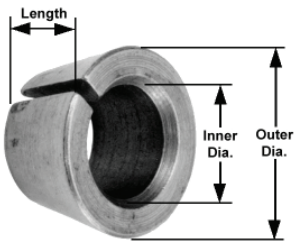





EUCLID NO.	O.D.	I.D.	LENGTH	REPLACES	APPLICATION AND GENERAL INFORMATION
E-10828	1-1/8"	3/4"	1/2"	Meritor 1246L350 Dayton/Batco 137224 Leland L2957	

RETURN SPRINGS

FOR 12-1/4" BRAKES





Return Spring colors are for identification purposes only. Colors do not indicate the type or quality of spring wire. Colors may or may not match colors used by OEM.



	EUCLID NO.	REPLACES	LENGTH	O. D.	APPLICATION AND GENERAL INFORMATION
	E-1025	Dayton/Batco 01326 Dana/Spicer 11528 Dayton/Batco 1364 Dana/Spicer 19858 Standard Forge 208105 HalDEX 65360 Eaton 70325 Wagner 914100 HalDEX C66753 Leland L417 Dana/Spicer M10WJ115 Dana/Spicer M10WJ155 Meritor R567011	4-3/16"	3/4"	For 12-1/4" Brakes. Heavy-Duty Version of E-1025 .109 Dia. Wire
	E-2101	Dayton/Batco 01364 Dana/Spicer 11528 Dana/Spicer 19857 Standard Forge 208105 Eaton 70325 HalDEX C63037 Navistar IT19857 Leland L1782 Dana/Spicer M10WJ115 Meritor R567001 Meritor R567011	4-3/16"	3/4"	For 12-1/4" Brakes Heavy-Duty version of E-1025 .120 Dia. Wire
	E-1402	Dayton/Batco 01341 Trailmobile 15174 Dana/Spicer 19864 HalDEX 66634 Eaton 820276 Sirco B426 Eaton B866 HalDEX C66652 Leland L1034 Meritor R567004	5"	1"	Eaton 12-1/4" Brake used with both fabricated and steel cast shoes at anchor pin end for "S" type cams. Available only in brake kit E-2126.
	E-1400	Dayton/Batco 01345 Eaton 1003817 Dana/Spicer 19866 HalDEX 66636 Eaton 78580 Eaton 820164 Eaton B2010 Sirco B427 HalDEX C66653 Leland L1035 Meritor R567003	6"	1/2"	For 12-1/4" Brakes With Pressed Steel Shoe Only. Use 2 Springs per Shoe
	E-757	Dayton/Batco 01339 Dana/Spicer 19862 Standard Forge 208106 Meritor 2258V256 HalDEX 65444,66635, C66849 Sirco B256; Leland L385 Dana/Spicer M10WJ118 Dana/Spicer M10WJ135	6-1/4"	1"	For Std. Forge 12-1/4" Brake and Meritor 16-1/4" x 3-1/2" "T" Series Brake

RETURN SPRINGS



FOR 12-1/4" BRAKES

	EUCLID NO.	REPLACES	LENGTH	O.D.	APPLICATION AND GENERAL INFORMATION
	E-2398	Dayton/Batco 01330 Dayton/Batco 01331 Dayton/Batco 1339 Dana/Spicer 19862 Eaton 2-2121 Standard Forge 208106 Meritor 2258V256 Trailmobile 382398 Haldex 67492 Eaton 80752 Sirco B307 Haldex C67492 Leland L1279 Leland L3148 Dana/Spicer M10WJ118 Meritor R567005	6-9/16"	1"	For 12-1/4" Brakes, Heavy-Duty Version of E-757
	E-1583	Dayton/Batco 01350 Dana/Spicer 19863 Fruehauf ACD002287001 Sirco B869 Haldex C67446 Navistar IT19863 Leland L1695 Meritor R567002	6-3/4"	1-1/8"	For Fruehauf "Pro-Par" Axle 12-1/4" Brakes
	E-3481A	Dayton/Batco 01378 Dana/Spicer 19882 Meritor 2258B704 Meritor 2258T124 Sirco B308 Leland L2351	6-7/8"	1-1/8"	For Meritor 12-1/4" "Q" Brake

FOR 14-1/2" COACH BRAKES









	EUCLID NO.	REPLACES	LENGTH	O.D.	APPLICATION AND GENERAL INFORMATION
	E-10826	Meritor 2258J400 Sirco BP106 Leland L574	8-1/2"	1-1/4"	"W" Series Type 1, 2 and 3
	E-10818	Meritor 2258J1440 Meritor 2258K401 Sirco BP100 Leland L573	8-11/16"	5/8"	Steer Axle 14-1/2" x 4", 5", and 6" "W" Series

FOR 15" BRAKES

	EUCLID NO.	REPLACES	LENGTH	O.D.	APPLICATION AND GENERAL INFORMATION
	E-9037	Eaton 817017 Sirco B433 Haldex C63054 Leland L3173 Meritor R567012	3-9/16"	1-3/16"	For Eaton 15" x 6" "ES" Reduced Envelope Front Axle Brake. Requires two springs per brake assembly
	E-5123	Dayton/Batco 01358 Eaton 1006562 Dana/Spicer 19923 Eaton 2-2116 Haldex 66836 Eaton 78925 Wagner 914116 Sirco B562 Haldex C66836 Leland L2829 Meritor R567009	7-1/8"	13/16"	For Eaton 15" Front Brakes

RETURN SPRINGS

FOR 15" BRAKES





	EUCLID NO.	REPLACES	LENGTH	O.D.	APPLICATION AND GENERAL INFORMATION
	E-3437	Dayton/Batco 01373 Dayton/Batco 01374 Dana/Spicer 19895 Dana/Spicer 19896 Meritor 2258G579 Trailmobile 383437 Navistar 487473C1 Wagner 914109 Sirco B579 Haldex C66842 Leland L1734	7-3/16"	7/8"	For Meritor "T" Series 15" Front Brake
	E-980	Dayton/Batco 01343 Dana/Spicer 19884 GMC 3772286 Haldex 66643 Haldex C66643 Wagner FD31958 Leland L465 Meritor R567016	7-1/2"	1-3/32"	For Wagner 15" Drive Axle Brakes
	E-3872	Dayton/Batco 01363 Dana/Spicer 19902 Meritor 2258K1181 Trailmobile 383872 Sirco B952 Haldex C66853 Leland L2931	7-11/16"	13/16"	For Meritor 15" x 4" "Q" Brake
	E-9063	Dayton/Batco 01-3696 Dayton/Batco 13696 Meritor 2258L1234 Sirco B956 Haldex C63043 Leland L3069	8-3/8"	1-1/8"	For Meritor 15" Q Plus™ Brake
	E-11980	Dana/Spicer 974642 Meritor R567526	9-3/16"	1-1/8"	For Eaton 15" "ES" "Extended Service" steer axle brakes with double web shoe. FMSI 4729
	E-979	Dayton/Batco 01376 Dana/Spicer 19890 GMC 3774253 Haldex 66886 Haldex C66886 Wagner F31922 Leland L1672 Leland L464 Meritor R567014	9-1/2"	5/8"	For Wagner 15" x 3", 3-1/2" Front Brakes.
	E-2770	Dayton/Batco 01377 Dana/Spicer 19891 Sirco B870 Haldex C66880 Wagner FC89177 Wagner FC89178 Wagner FC897778 Leland L1693 Meritor R567015	10-1/8"	1"	For Wagner 15" x 4" Front Axle Brake. Three piece assembly
	E-9038	Eaton 812992 Sirco B436 Haldex C63051 Leland L3175, L3370 Meritor R567013	10-1/8"	1-1/8"	For Eaton 15" x 8-5/8" "ES" Reduced Envelope Drive Axle Brake

RETURN SPRINGS

FOR 16-1/4" BRAKES





	EUCLID NO.	REPLACES	LENGTH	O. D.	APPLICATION AND GENERAL INFORMATION
 <p>BLACK</p>	E-757	Dayton/Batco 01339	6-1/4"	1"	For Std. Forge 12-1/4" Brake and Meritor 16-1/4" x 3-1/2" "T" Series Brake
		Dana/Spicer 19862			
		Standard Forge 208106			
		Meritor 2258V256			
		Haldex 65444			
		Haldex 66635			
		Sirco B256			
		Haldex C66849			
		Leland L385			
		Dana/Spicer M10WJ118			
		Dana/Spicer M10WJ135			

FOR 16-1/2" BRAKES

	EUCLID NO.	REPLACES	LENGTH	O. D.	APPLICATION AND GENERAL INFORMATION
 <p>ORANGE</p>	E-9046	Dayton/Batco 013863	6-21/32"	1-1/4"	For Eaton 16-1/2" x 7" "ES" Severe Service Brake with Cast Shoes
		Eaton 807930			
		Leland L3022			
		Meritor R567020			
 <p>BLACK</p>	E-544	Dayton/Batco 01324	7-1/2"	1-1/8"	For Std. Forge Cast Shoes
		Dayton/Batco 01355			
		Standard Forge 208104			
		Gunite 4023			
		Navistar 62333R1			
		Haldex 65310			
		Trailmobile 700747			
		Wagner 914108			
		Leland L116			
		Dana/Spicer M10WJ154			
		Meritor R567024			
 <p>BLACK</p>	E-752	Dayton/Batco 01335	7-7/8"	1-1/8"	For 16-1/2" Mack Old Style Cast Shoes
		Dana/Spicer 19870			
		Trailmobile 38752			
		Haldex 65428			
		Leland L375			
		Meritor R567023			
 <p>GREEN</p>	E-545A	Dayton/Batco 01321	8"	1-1/8"	For Standard "P" Style Brakes. Use E-1880B for Heavy-Duty Application
		Dayton/Batco 01354			
		Dana/Spicer 11227			
		Trailmobile 19116			
		Dana/Spicer 19852			
		Eaton 2-2117			
		Standard Forge 208102			
		Fruehauf 219310			
		Meritor 2258P354			
		Trailmobile 37080			
		Trailmobile 38545A			
		Navistar 62322R1			
		Haldex 65337			
		Trailmobile 7-8-1			
		Trailmobile 700721			
		Eaton 79291			
		Wagner 914105			
		Sirco B971			
		Leland L179			
		Dana/Spicer M10WJ135			





RETURN SPRINGS

FOR 16-1/2" BRAKES

EUCLID NO.	REPLACES	LENGTH	O.D.	APPLICATION AND GENERAL INFORMATION
 <p>E-1880B</p>	Dayton/Batco 01322 Dayton/Batco 01352 Dana/Spicer 11227 Dana/Spicer 19853 Eaton 2-2118 Standard Forge 208102 Fruehauf 219310 Meritor 2258Z416 Trailmobile 381880B Navistar 62322R1 Haldex 65449 Trailmobile 700795 Eaton 79656 Sirco B728 Haldex C65449 Navistar IT19853 Leland L827 Dana/Spicer M10WJ135	8"	1-1/4"	100 lb. "Mega Plus" spring for 18" Brakes. Heavy-Duty version of E-545A. Use for Spicer "XL" Brakes and Meritor "P" Brakes.
 <p>E-1880S</p>	Dana/Spicer 19853 Wagner 914107 Sirco B728	8"	1-1/4"	For 16-1/2" Brakes. Heavy-Duty Wire, 80 lb. tension, not shot-peened. Found in "Stopmate Plus" Brake Repair Kits. Same applications as E-1880B.
 <p>E-3228</p>	Dayton/Batco 01359 Dana/Spicer 19883 Eaton 2-2119 Trailmobile 383228 Eaton 80021 Wagner 914113 Fruehauf ACE009911001 Fruehauf ACE009911EX1 Fruehauf ACE009911PKG Haldex C67470 Leland L2098 Meritor R567008	8-3/8"	1-1/8"	For 16-1/2" Fruehauf "XEM" Brake
 <p>E-2768</p>	Dayton/Batco 01346 Dayton/Batco 01359 Dayton/Batco 01369 Dana/Spicer 19856 Eaton 2-2120 Meritor 2258U619 Trailmobile 382768 Navistar 492283C1 Haldex 66864 Trailmobile 7007142 Eaton 80386 Wagner 914111 Sirco B302 Haldex C66864 Navistar IT19856 Leland L1418 Leland L3067 Dana/Spicer M16WJ100	8-3/8"	1-1/8"	For 16-1/2" Brakes with Shoe Return Spring for Meritor "Q" and Spicer "Fast Change". Use with E-2767 Spring.

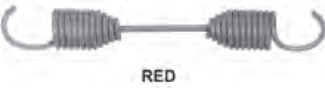



RETURN SPRINGS

FOR 16-1/2" BRAKES

EUCLID NO.	REPLACES	LENGTH	O.D.	APPLICATION AND GENERAL INFORMATION
 <p>RED</p>	E-3490B Dayton/Batco 01379 Dayton/Batco 1346 Dayton/Batco 1369 Dana/Spicer 19853A Meritor 2258U619 Meritor 2258W803 Trailmobile 383490B Haldex 66565 Trailmobile 7007225 Trailmobile 700795 Wagner 914114 Fruehauf ACE009911PKG Fruehauf ACF006414001 Holland Hitch ACF64141 Sirco B349 Leland L2370 Dana/Spicer M16WJ100 Meritor R567010	8-3/8"	1-1/4"	100 lb. "Mega Plus" spring. Heavy-Duty Version of E-2768 and E-3228. Use for Meritor Q Plus™
	Leland 2370 Leland L2370	8-3/8"	1-1/4"	Heavy-Duty wire, 80 lb. tension, not shot-peened. Found in "Stopmate Plus" Brake Repair Kits. Same applications as E-3490B.
 <p>BROWN</p>	E-8907 Dayton/Batco 01-3862 Dayton/Batco 13862 Eaton 810292 Sirco B350 Haldex C63047 Leland L3118 Meritor R567022	8-13/32"	1-1/8"	For Eaton 16-1/2" x 7" "ES" Severe Service Brake with fabricated shoes and Eaton "Top Spec ES" retrofit for Fruehauf and Meritor brakes.
	Dayton/Batco 01372 Dana/Spicer 19913 Meritor 2258S643 Sirco B347 Haldex C63045 Leland L1383 Leland L3183	8-9/16"	1-1/8"	Bent Center Bar for Meritor 16-1/2" Front "Q" Brakes on "FL" Series Axles
 <p>YELLOW</p>	E-543 Dayton/Batco 01323 Dana/Spicer 19878 Fruehauf 219311 Meritor 2258K349 Meritor 2258R349 Trailmobile 44750 Navistar 56109R1 Haldex 65309 Trailmobile 7-8-22 Sirco B974 Haldex C66614 Leland L115	9"	1-1/8"	Used on 16-1/2" x 6" x 7" Shoes. Also 18" x 7" Brakes with Cast Shoe.
	Dayton/Batco 01-3751 Dayton/Batco 01375 Dayton/Batco 13751 Dana/Spicer 19910 Meritor 2258Y1273 Sirco B348 Sirco B871 Haldex C67320 Leland L2843 Leland L3126	9-1/16"	1-3/16"	For 16-1/2" Brakes with relocated return spring shoes and Q Plus™ camshafts. Can also be used on "Hammer Claw" camshafts
 <p>BLACK</p>	E-9069 Dayton/Batco 01372 Dana/Spicer 19913 Meritor 2258S643 Sirco B347 Haldex C63045 Leland L1383 Leland L3183	8-9/16"	1-1/8"	Bent Center Bar for Meritor 16-1/2" Front "Q" Brakes on "FL" Series Axles
	Dayton/Batco 01-3751 Dayton/Batco 01375 Dayton/Batco 13751 Dana/Spicer 19910 Meritor 2258Y1273 Sirco B348 Sirco B871 Haldex C67320 Leland L2843 Leland L3126	9-1/16"	1-3/16"	For 16-1/2" Brakes with relocated return spring shoes and Q Plus™ camshafts. Can also be used on "Hammer Claw" camshafts
 <p>GREEN</p>	E-9643 Dayton/Batco 01-3751 Dayton/Batco 01375 Dayton/Batco 13751 Dana/Spicer 19910 Meritor 2258Y1273 Sirco B348 Sirco B871 Haldex C67320 Leland L2843 Leland L3126	9-1/16"	1-3/16"	For 16-1/2" Brakes with relocated return spring shoes and Q Plus™ camshafts. Can also be used on "Hammer Claw" camshafts

RETURN SPRINGS

FOR 16-1/2" BRAKES



EUCLID NO.	REPLACES	LENGTH	O.D.	APPLICATION AND GENERAL INFORMATION
 E-2475	Dayton/Batco 01362 Eaton 1000406 Dana/Spicer 19874 Eaton 2-3685 Navistar 462424C1 Eaton 651992 Sirco B983 Haldex C67786 Leland L1603 Meritor R567017	10"	1-3/16"	For Eaton 16-1/2" Brakes on Front Axle and Drive Axles with High Mount Shoes
 E-10197	Dayton/Batco 01386 Dayton/Batco 013864 Dana/Spicer 19915 Eaton 2806235 Eaton 2818278 Dayton/Batco 717338 Sirco B432A Haldex C63060 Leland L2962 Meritor R567503	10-3/4"	1-1/8"	100 lb. "Mega Plus" spring for Eaton 16-1/2" "ES" and "ES-II" Brake
 E-2785	Dayton/Batco 01356 Eaton 1003817 Dana/Spicer 19875 Eaton 2-3685 Eaton 651992 Haldex 65450 Eaton 78580 Wagner 914121 Navistar IT19875 Leland L1630 Meritor R567001	10-3/4"	1-5/32"	Alternate Spring for Eaton 16-1/2" Single Anchor Pin Brake. For extra spindle clearance.
 E-1428A	Dayton/Batco 01349 Navistar 142919R3 Dana/Spicer 19854 Eaton 2-2122 Trailmobile 381428A Navistar 472976C1 Haldex 65450 Trailmobile 7007183 Trailmobile 700799 Eaton 78580 Eaton 81117 Sirco B981 Haldex C65450 Leland L835 Meritor R567006	10-13/16"	1-1/8"	100 lb. "Mega Plus" spring for Eaton 16-1/2" Standard Single Anchor Pin Brake. For Alternate Spring use E-2785.
 E-1428S	Dana/Spicer 19854 Wagner 914119	10-13/16"	1-1/8"	For 16-1/2" Brakes. Heavy-Duty wire, 100 lb. tension, not shot-peened. Found in "Stopmate Plus" Brake Repair Kits. Same applications as E-1428A.

FOR 18" BRAKES

EUCLID NO.	REPLACES	LENGTH	O.D.	APPLICATION AND GENERAL INFORMATION
 E-3512	Dayton/Batco 01371 Dana/Spicer 19865 Meritor 2258R590 Haldex 66612 Sirco B972 Haldex C66612 Leland L2858	6"	3/4"	For Meritor 18" brake using E-3513 spring retainer

RETURN SPRINGS

FOR 18" BRAKES





EUCLID NO.	REPLACES	LENGTH	O.D.	APPLICATION AND GENERAL INFORMATION
 <p>RED</p>	E-1880B Dayton/Batco 01322 Dayton/Batco 01352 Dana/Spicer 11227 Dana/Spicer 19853 Eaton 2-2118 Standard Forge 208102 Fruehauf 219310 Meritor 2258Z416 Trailmobile 381880B Navistar 62322R1 Haldex 65449 Trailmobile 700795 Eaton 79656 Sirco B728 Haldex C65449 Navistar IT19853 Leland L827 Dana/Spicer M10WJ135	8"	1-1/4"	100 lb. "Mega Plus" spring for 18" Brakes. Heavy-Duty version of E-545A. Use for Spicer "XL" Brakes and Meritor "P" Brakes.
	Dayton/Batco 01323 Dana/Spicer 19878 Fruehauf 219311 Meritor 2258K349 Meritor 2258R349 Trailmobile 44750 Navistar 56109R1 Haldex 65309 Trailmobile 7-8-22 Sirco B974 Haldex C66614 Leland L115	9"	1-1/8"	Used on 16-1/2" x 6" x 7" Shoes. Also 18" x 7" Brakes with Cast Shoe.
 <p>BLACK</p>	E-2804 Dayton/Batco 01360 Eaton 1000091 Dana/Spicer 19876 Eaton 2-3689 Navistar 474497C9 Eaton 653453 Sirco B982 Haldex C66607 Eaton EB1000091 Leland L1624 Meritor R567027	11-3/8"	1-1/4"	For Eaton 18" x 7" Brake.
	Dayton/Batco 07136 Navistar 264621C1 Meritor 2758Q43 Haldex 66447 Haldex C66447 Leland L968	6"	9/16"	For "RS" Brakes and Pre-121 15" "RD" Brakes.
 <p>GREEN</p>	E-1458 Dayton/Batco 07136 Navistar 264621C1 Meritor 2758Q43 Haldex 66447 Haldex C66447 Leland L968	6"	9/16"	For "RS" Brakes and Pre-121 15" "RD" Brakes.
	Dayton/Batco 07536 Bendix 316367 Bendix 316392 Haldex 65414 Haldex 66679 Haldex C66753 Haldex CS66679 Leland L1065 Meritor R670010	6-9/16"	5/8"	For Bendix "Non-Servo" Front Brakes

FOR WEDGE BRAKES



EUCLID NO.	REPLACES	LENGTH	O.D.	APPLICATION AND GENERAL INFORMATION
 <p>GREEN</p>	E-1458 Dayton/Batco 07136 Navistar 264621C1 Meritor 2758Q43 Haldex 66447 Haldex C66447 Leland L968	6"	9/16"	For "RS" Brakes and Pre-121 15" "RD" Brakes.
	Dayton/Batco 07536 Bendix 316367 Bendix 316392 Haldex 65414 Haldex 66679 Haldex C66753 Haldex CS66679 Leland L1065 Meritor R670010	6-9/16"	5/8"	For Bendix "Non-Servo" Front Brakes

RETURN SPRINGS







FOR WEDGE BRAKES

	EUCLID NO.	REPLACES	LENGTH	O. D.	APPLICATION AND GENERAL INFORMATION
	E-2163	Dayton/Batco 07535 Bendix 249942 Haldex C65414 Leland L1765 Meritor R670020	7-1/2"	15/16"	For "Twin-plex" Drive and Trailer Wedge Brakes. Use with E-2164 Damper.
		Dayton/Batco 07134 Trailmobile 12608 Trailmobile 16101 Meritor 2258E629 Navistar 266303C1 Navistar 491688C1 Haldex 65385 Haldex 66640 Trailmobile 7-8-34 Trailmobile 700749 Haldex C66425 Leland L1286 Leland L2856 Leland L579			
	E-2745	Dayton/Batco 07537 Bendix 324095 Bendix 324095N Haldex C63042 Leland L1769 Meritor R670024	8-3/8"	15/16"	For Bendix "Non-Servo" Front Brake
	E-2476	Dayton/Batco 07137 Meritor 2758W127 Navistar 295610C1 Dayton/Batco 7138 Haldex C66455 Leland L1650	8-3/8"	1"	For Meritor Front Axle Wedge Brake Square Connecting Rod For Application on Cast Spider

RETAINER SPRINGS

	EUCLID NO.	REPLACES	LENGTH	O. D.	APPLICATION AND GENERAL INFORMATION
	E-5122	Dayton/Batco 01357 Eaton 1003999 Dana/Spicer 19922 Eaton 2-2125 Eaton 82213 Wagner 914112 Sirco B999 Haldex C66835 Leland L2825 Meritor R567501	3-7/8"	5/8"	For Eaton 15" Front Brakes
		Dayton/Batco 01348 Dana/Spicer 19859 Eaton 2-2123 Trailmobile 381418 Navistar 385960C1 Haldex 65320 Trailmobile 700751 Eaton 70326 Eaton 81482 Wagner 914115 Sirco B769 Haldex C65320 Navistar IT19859 Leland L967 Meritor R567502			

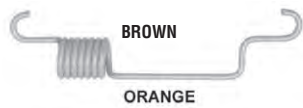
RETAINER SPRINGS

EUCLID NO.	REPLACES	LENGTH	O.D.	APPLICATION AND GENERAL INFORMATION
 GREEN	E-2805 Dayton/Batco 01361 Eaton 1000092 Dana/Spicer 19877 Navistar 474498C1 Sirco B770 Haldex C66606 Eaton EB1000092 Leland L1625 Leland L2985 Meritor R567028	4-5/8"	1-1/4"	Retainer Spring for Eaton 18" x 7" Brake
 UNPAINTED	E-5305 Dayton/Batco 01305 Standard Forge 208106 Trailmobile 385305 Haldex 67488 Sirco B218 Haldex C67488 Leland L2367 Dana/Spicer M10WJ150 Meritor R547011	5"	3/16"	For Spicer 12-1/4" x 7-1/2" "U" Brake
 BLUE	E-3873 Dayton/Batco 01380 Dana/Spicer 19903 Meritor 2258E1123 Trailmobile 383873 Sirco B953 Haldex C66854 Leland L2932	5-9/32"	5/8"	For Meritor 15" x 4" "Q" Brake
 ORANGE	E-2767 Dayton/Batco 01370 Dana/Spicer 19860 Eaton 2-2124 Meritor 2258Q615 Eaton 2809513 Trailmobile 382767 Haldex 66863 Trailmobile 7007141 Eaton 81847 Wagner 914110 Fruehauf ACF003079001 Fruehauf ACF003079PK1 Holland Hitch ACF30791 Sirco B220 Haldex C66863 Navistar IT19860 Leland L1417 Dana/Spicer M16WJ101	5-1/2"	3/4"	For Eaton 15" x 8- 5/8" "Reduced Envelope", Fruehauf "XEM", Spicer and Meritor 12-1/4", 16-1/2" "Q" and Q Plus™
 BROWN ORANGE	E-14657 Bendix/Spicer HK49-150 Haldex CQ67437 Meritory R507017	5-1/2"	4/5"	For Spicer (Dana) 12 1/4" ABS Brakes
 BROWN ORANGE	E-10198 Dayton/Batco 013481 Eaton 819725 Sirco B434 Haldex C63005 Leland L3369 Meritor R567505	5-1/2"	13/16"	For Eaton 16-1/2" x 7" "ES-II" Brake. Install with Coil End up.
 BLUE	E-5088 Dayton/Batco 01381 Meritor 2258X804 Sirco B221 Haldex C63058 Leland L2953	6-5/16"	3/4"	For Mack with Meritor 16-1/2" "Q" Brake on 50,000 lb. Rear Axles

CAM RETURN SPRING RETAINERS

EUCLID NO.	REPLACES	LENGTH	O.D.	APPLICATION AND GENERAL INFORMATION
E-3513	Dayton/Batco 01314 Meritor 1218C107 Dana/Spicer 341565 Navistar 493186C1 Sirco B973 Haldex C66611 Leland L2859			Use with Meritor 18" Brakes
E-2399	Dayton/Batco 01318 Eaton 2-2114 Standard Forge 207100 Dana/Spicer 20882 Trailmobile 382399 Eaton 78195 Sirco B358 Haldex C67471 Leland L1535 Dana/Spicer M10WJ119 Meritor R577001	2-1/8"	15/32"	For Alternate Version use E-747
E-10822	Meritor 1246R382	2-5/32"	27/64"	Use with Meritor Coach 14-1/2" Brakes
E-747	Dayton/Batco 01320 Dana/Spicer 11228 Trailmobile 11516 Meritor 1218G85 Eaton 2-2115 Standard Forge 207102 Dana/Spicer 20881 Eaton 2809512 Trailmobile 38747 Fruehauf 583015 Haldex 65351 Trailmobile 7-12-31 Trailmobile 700722 Eaton 78560 Wagner 914090 Navistar 983622R1 Sirco B423 Haldex C65351 Leland L324 Dana/Spicer M16WJ102	2-3/4"	1/4"	Use with Fabricated Shoes for Kershaw, Fruehauf, Shuler, Meritor, Spicer (Dana) and Std. Forge
E-10811	Meritor 1746U47	2-25/32"	27/64"	Use with Meritor Coach 14-1/2" Brakes
E-2109	Dayton/Batco 01319 Dana/Spicer 20883 Eaton 820202 Eaton B2154 Haldex C67502 Navistar IT20883 Leland L1627 Meritor R527003	3"	1/4"	Used on Eaton 22L and 23L

BRAKE BLOCK BOLTS



EUCLID NO.	DESCRIPTION	REPLACES RIVET	SIZE		
			THREAD	LENGTH	THREAD TYPE
E-633X	Brass Brake Bolt	NO. 8	3/16"-32	1"	SAE Fine
E-634X		NO. 10	1/4"-28		
E-917X	Brass Brake Bolt with Keps Nut	NO. 8	3/16"-24	1"	USS Coarse
E-918X		NO. 10	1/4"-28		
E-998X	Steel Brake Bolt	NO. 8	3/16"-32	1"	SAE Fine
E-999X		NO. 10	1/4"-28		



EUCLID NO.	DESCRIPTION	THREAD	SIZE	
			LENGTH	THREAD TYPE
E-798X	Brass Brake Bolt	3/8"-16	1"	USS Coarse
E-628X			1-1/4"	
E-635X	Brass Brake Bolt	3/8"-24	1-1/2"	SAE Fine
E-797X			1"	
E-636X	Brass Brake Bolt with Keps Nut	3/8"-16	1-1/4"	USS Coarse
E-583X			1-1/2"	
E-916X	Brass Brake Bolt with Keps Nut	3/8"-24	1"	SAE Fine
E-914X			1-1/4"	
E-912X	Brass Brake Bolt with Keps Nut	3/8"-24	1-1/2"	SAE Fine
E-915X			1"	
E-913X	Brass Brake Bolt with Keps Nut	3/8"-24	1-1/4"	SAE Fine
E-911X			1-1/2"	

EUCLID SEMI-TUBULAR RIVETS

BRASS

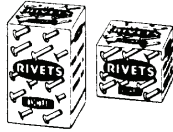

To eliminate all possible confusion and to insure that the correct quantities will be shipped, we request that you order rivets as follows:

- EXAMPLE**
- "B" = Brass Rivets
 - "S" = Brass-Plated Steel Rivets
 - 7-6B = Brass in 100 per box
 - 7-6B-BK = Brass in 1000 per box
 - 7-6S = Steel in 100 per box
 - 7-6S-BK = Steel in 1000 per box

SIZE	LENGTH	EUCLID NO.
9/64" Body x 5/16" Head	1/4"	4-4B
	9/32"	4-4.5B
	5/16"	4-5B
	3/8"	4-6B
	7/16"	4-7B
9/64" Body x 3/8" Head	1/4"	5-4B
	5/16"	5-5B
	3/8"	5-6B
	3/4"	5-12B
3/16" Body x 3/8" Head	1/4"	7-4B
	5/16"	7-5B
	3/8"	7-6B
	7/16"	7-7B
	1/2"	7-8B
	9/16"	7-9B
	5/8"	7-10B
	3/4"	7-12B
	1"	7-16B
3/16" Body x 1/2" Head	3/8"	8-6B
	7/16"	8-7B
	1/2"	8-8B
	9/16"	8-9B
	5/8"	8-10B
.195/.200" Body x 1/2" Head	3/4"	8-12B
	1/2"	20-8B
	9/16"	20-9B
1/4" Body x 1/2" Head	5/8"	20-10B
	1/2"	10-8B
	9/16"	10-9B
1/4" Body x 1/2" Head	5/8"	10-10B
	3/4"	10-12B

STEEL

SIZE	LENGTH	EUCLID NO.
3/16" Body x 3/8" Head	3/8"	7-6S
	7/16"	7-7S
3/16" Body x 1/2" Head	3/8"	8-6S
	7/16"	8-7S
	1/2"	8-8S
	9/16"	8-9S
	5/8"	8-10S
.195/.200" Body x 1/2" Head	1/2"	20-8S
	9/16"	20-9S
1/4" Body x 1/2" Head	7/16"	10-7S
	1/2"	10-8S
	9/16"	10-9S
	5/8"	10-10S

EUCLID RIVETS FOR IMPORT BRAKES

EUCLID NO.	DESCRIPTION	BODY DIAMETER	HEAD DIAMETER	LENGTH
E-7360	Brass Semi-Tubular	6mm	12mm	13/32"
E-7043	Steel Fully-Tubular	8mm	15mm	19/32"
E-7044	Steel Semi-Tubular	8mm	15mm	19/32"

BRAKE IDENTIFICATION:

HOW TO USE THIS CHART

- Compare Brake Shoe Profiles
- Compare Table End Views
- Compare Brake Block Drill Patterns
- Determine Which Type of Camshaft Each Brake Shoe Uses

"STANDARD" S-CAM HEAD

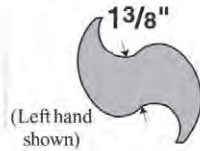

"EXTENDED LIFE" S-CAM HEAD

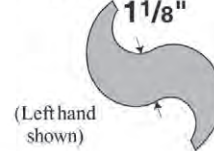

"STANDARD" BRAKES

BRAKE BLOCK DRILL PATTERN	TABLE	BRAKE TYPE
FMSI 4311J 28 Holes 3/4" Thick 10-8 Rivets	 anchor end view Use "std." OR "ext. life" camshaft	EATON E-1778
FMSI 4515E 32 Holes 3/4" Thick 10-8 Rivets	 roller end view Use "std." camshaft	FRUEHAUF "XEM" E-3920
FMSI 4515E 32 Holes 3/4" Thick 10-8 Rivets	 roller end view Use "std." OR "ext. life" camshaft	MERITOR "Q" E-2778
FMSI 4515E 32 Holes 3/4" Thick 10-8 Rivets	 roller end view Use "std." OR "ext. life" camshaft	MERITOR "Q" FOR FRUEHAUF E-6075
FMSI 4515E 32 Holes 3/4" Thick 10-8 Rivets	 roller end view Use "std." OR "ext. life" camshaft	SPICER "FAST CHANGE" E-2778

"EXTENDED LIFE" BRAKES

BRAKE TYPE	TABLE	BRAKE BLOCK DRILL PATTERN
EATON "ES I" E-5480	 anchor end view Use "ext. life" camshaft	FMSI 4709 28 Holes 7/8" Thick 10-9 Rivets
EATON "ES II" E-10272	 anchor end view Use "ext. life" camshaft	FMSI 4709 28 Holes 7/8" Thick 10-9 Rivets
EATON TOP SPEC "ES" FOR FRUEHAUF E-8922	 roller end view Use "std." camshaft	FMSI 4708 28 Holes 13/16" Thick 10-9 Rivets
MERITOR "Q PLUS" E-5503	 roller end view Use "ext. life" camshaft	FMSI 4707 28 Holes 7/8" Thick 10-9 Rivets
EATON TOP SPEC "ES" FOR MERITOR E-8924	 roller end view Use "std." OR "ext. life" camshaft	FMSI 4708 28 Holes 13/16" Thick 10-9 Rivets







"Standard" vs. "Extended Life"

"Standard" brakes use "standard" OR "extended life" camshafts.

Most "extended life" brakes use ONLY "extended life" camshafts.

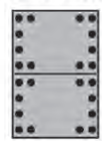









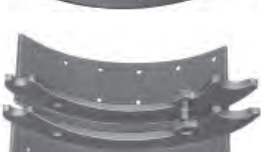

Fruehauf brakes use ONLY "standard" camshafts.

"EXTENDED LIFE" BRAKES

BRAKE TYPE	TABLE	BRAKE BLOCK DRILL PATTERN
<p>SPICER "XL"</p>  <p>E-2778</p>	 <p>roller end view</p> <p>Use "ext. life" camshaft</p>	<p>FMSI 4701</p>  <p>24 Holes 7/8" Thick 10-9 Rivets</p>
<p>SPICER "XL II"</p>  <p>E-5503</p>	 <p>roller end view</p> <p>Use "ext. life" camshaft</p>	<p>FMSI 4707</p>  <p>24 Holes 7/8" Thick 10-9 Rivets</p>

EUCLID BRAKE REPAIR KITS		
EUCLID SHOE NO.	BRAKE TYPE	EUCLID KIT NO.
E-1778	EATON	E-1887AHD E-1887ASHD
E-2778	MERITOR "Q" SPICER "FAST CHANGE"	E-2769HD E-2769S E-2769SHD
E-2778	SPICER "XL"	E-5515
E-3920	FRUEHAUF "XEM"	E-3710HD E-3710S E-3710SHD
E-5480	EATON "ES"	E-5481A
E-5503	MERITOR "Q PLUS" & SPICER "XL II"	E-2769HD E-2769SHD
E-6075	MERITOR "Q" FOR FRUEHAUF	E-2769HD E-2769S E-2769SHD
E-8922	EATON TOP SPEC "ES" FOR FRUEHAUF	E-8923
E-8924	EATON TOP SPEC "ES" FOR MERITOR	E-8925
E-10272	EATON "ES II"	E-10244

CAM BRAKE SHOES - 12-1/4" DIAMETER BRAKES

UNLINED SHOE NO.	REPLACES	SIZE	FMSI NO.	RIVET	USE BRAKE REPAIR KIT	APPLICATION
 E-9025	Dexter 40-164	12-1/4" x 4"	4700	8-	E-2402HD, E-2403HD	Dexter
 E-9026	Dexter 40-165	12-1/4" x 5"	4661C	8-	E-2402HD, E-2403HD	Dexter
 E-10876	Dexter 40-321	12-1/4" x 4"	4700	8-	E-10875	Dexter "PQ"
 E-10877	Dexter 40-322	12-1/4" x 5"	4661C	8-	E-10875	Dexter "PQ"
 E-10878	Dexter 40-320	12-1/4" x 7-1/2"	4591	8-	E-10875	Dexter "PQ"
 E-1398	Eaton 820173	12-1/4" x 7-1/2"	4591	20-8	E-2126	Eaton "FTL" and "SA" Type
 E-1580	Fruehauf ACD-002227-001	12-1/4" x 8"	4649	20-8	E-2286	Fruehauf "Pro-Par"
 E-3491	Meritor A3222S1527	12-1/4" x 7-1/2"	4670	10-9	E-3484	Meritor "Q" Brake
 E-10762	Spicer M12WS173X (4536FC11)	12-1/4" x 5-1/2"			E-10757 (early version), E-10756 (later version)	Spicer
 E-10763	Spicer M12WS166X (4692FC11)	12-1/4" x 7-1/2"	4692		E-10757 (early version), E-10756 (later version)	Spicer
 E-2393A	Spicer and Standard Forge Spicer M12WS151X	12-1/4" x 5-1/2"	4536E	20-8	E-3373HD, E-3374HD, E-9281, E-9282	Spicer and Std. Forge Standard Version
 E-2394A	Spicer and Standard Forge Spicer M12WS148X	12-1/4" x 7-1/2"	4692	10-8	E-3373HD, E-3374HD, E-9281, E-9282	Spicer and Std. Forge Standard Version

CAM BRAKE SHOES - 12-1/4" DIAMETER BRAKES



UNLINED SHOE NO.	REPLACES	SIZE	FMSI NO.	RIVET	USE BRAKE REPAIR KIT	APPLICATION
E-5303A	Spicer and Standard Forge Spicer (New) M12WS149X, Spicer (Old) M12KB251X, Spicer (Old) M12WS129X, Std Forge 204102	12-1/4" x 7-1/2"	4692	10-8	E-3782, E-9283	Spicer and Std. Forge "U" Brake
E-2393	Standard Forge 201142 Spicer M12WS122X	12-1/4" x 5-1/2"	4536B	20-8	E-2402HD, E-2403HD	Standard Forge Heavy-Duty Version for Severe Service
E-2394	Standard Forge 201140 Spicer M12WS127X	12-1/4" x 7-1/2"	4591	20-8	E-2402HD, E-2403HD	Standard Forge Heavy-Duty Version for Severe Service

COACH BRAKE SHOES - 14-1/2" DIAMETER BRAKES

















UNLINED SHOE NO.	REPLACES	SIZE	FMSI NO.	RIVET	USE BRAKE REPAIR KIT	APPLICATION
E-10802	Meritor A27-3722B366	14-1/2" x 4"	4227G	3/8" Bolt	E-10841-A	Meritor Coach
E-10804	Meritor A31-3722D368	14-1/2" x 5"	4398B	3/8" Bolt	E-10866-A	Meritor Coach
E-10803	Meritor A4-3222M1157	14-1/2" x 6"	4228B	3/8" Bolt	E-10841-A	Meritor Coach
E-10805	Meritor A24-3722P406	14-1/2" x 8"	4541B	3/8" Bolt	E-10867	Meritor Coach
E-10809	Meritor A1-3722J686	14-1/2" x 10"	4592A	3/8" Bolt	E-10870	Meritor Coach
E-10810	Meritor A1-3722R824	14-1/2" x 10"	4592A	3/8" Bolt	E-10869	Meritor Coach

WEDGE BRAKE SHOES - 15" DIAMETER BRAKES





UNLINED SHOE NO.	REPLACES	SIZE	FMSI NO.	RIVET	USE BRAKE REPAIR KIT	APPLICATION
E-1489	Bendix 316997	15" x 6"	4605	10-9	E-2157	For Bendix Spider Mounted Wedge Brake (Twin-Plex)
E-1457	Meritor A3722E681	15" x 3-1/2"	4562A	8-7	See Meritor Wedge Brake Section	Meritor "Stopmaster"
E-2689	Meritor A3722T358	15" x 5"	4615	10-9	See Meritor Wedge Brake Section	Meritor "Stopmaster"
E-1139	Meritor A3222S2021	15" x 7"	4602	10-9	See Meritor Wedge Brake Section	Meritor "Stopmaster"
E-3495	Meritor A3222V1088	15" x 4"	1308	10-7	See Meritor Wedge Brake Section	Meritor RSA "Stopmaster". Mfg. Stamping No.: 3222-T-1086 (Web); 3222-B-1094 (Table)

CAM BRAKE SHOES - 15" DIAMETER BRAKES

	UNLINED SHOE NO.	REPLACES	SIZE	FMSI NO.	RIVET	USE BRAKE REPAIR KIT	APPLICATION
	E-7230	Bendix 2259428	15" x 4"	4693	10-	E-7231	Ford Cargo Front Drum Brake
	E-11982	Eaton 974584	15" x 4"	4729	10-7	E-11981	Eaton Single Anchor Pin Front Axle for "ES" "Extended Service" brakes. Double web.
	E-5126	Eaton 1005840	15" x 4"	1308	10-7	E-5139	Eaton Single Anchor Pin Front Axle
	E-9027	Eaton 807685	15" x 4"	1443TT	10-7	E-5139	Eaton "ES" "Extended Service" Front Axle. Single web. Stamping No.: 807686
	E-9140	Eaton 816077	15" x 6"	4716	10-	E-9141	Eaton "Reduced Envelope" Brake
	E-9036	Eaton 813005	15" x 8-5/8"	4717	10-	E-9039	Eaton "Reduced Envelope" Brake
	E-3438	Meritor A3222K1103	15" x 3-1/2"	1307	10-8	E-4691, E-6879	Meritor "T" Brake Front Axle. Mfg. Stamping No.: 3222-S-1085 (Web); 3222-A-1093 (Table)
	E-3439	Meritor A3222F1072	15" x 4"	1308	10-7	E-4691, E-6879	Meritor "T" Brake Front Axle. Mfg. Stamping No.: 3222-S-1085 (Web); 3222-B-1094 (Table)
	E-5528	Meritor A3222F1982	15" x 4"	1308T	10-7	E-3869, E-7899	Meritor "Q" Brake Front Axle. Mfg. Stamping No.: 3222-D-1980 (Web); 3222-B-1094 (Table)
	E-9062	Meritor A3222M2223 Meritor A21-3222M2223	15" x 4"	4702	10-9	E-9064	Meritor Q Plus™ Brake. Mfg. Stamping No.: 3222-F-2164 (Web); 3222-W-1947 (Table)
	E-11453	Meritor A3222D2110	15" x 5"	4703	10-9	E-9064	Meritor Q Plus™ Brake. Front Axle. Mfg. Stamping No.: 3222-B-2108 (Web); 3222-R-1968 (Table)
	E-11454	Meritor A3222E2111	15" x 6"	4704	10-9	E-9064	Meritor Q Plus™ Brake. Front Axle. Mfg. Stamping No.: 3222-B-2108 (Web); 3222-E-1955 (Table)
	E-11455	Meritor A3222F2112	15" x 7"	4705	10-9	E-9064	Meritor Q Plus™ Brake. Rear Drive or Trailer Axle. Mfg. Stamping No.: 3222-B-2108 (Web); 3222-X-1948 (Table)
	E-11456	Meritor A3222A2159	15" x 8-5/8"	4710	10-9	E-9064	Meritor Q Plus™ Brake. Drive and Trailer Axle. Mfg. Stamping No.: 3222-B-2108 (Web); 3222-B-2160 (Table)

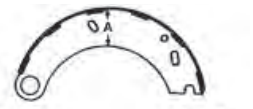





CAM BRAKE SHOES - 15" DIAMETER BRAKES

UNLINED SHOE NO.	REPLACES	SIZE	FMSI NO.	RIVET	USE BRAKE REPAIR KIT	APPLICATION
 E-2728	Wagner FE-83177	15" x 3-1/2"	1279	8-7	E-2740	Wagner Front Axle
	Wagner FE-32462					
 E-2729	Wagner FE88633	15" x 4"	1308A	8-7	E-3291	Wagner Front Axle. 5/16" Thick Web; "A" = 2-15/32"
 E-4785	Wagner FE100307	15" x 4"	1308A	8-7	E-3291	Wagner Front Axle. Special for Navistar 7/32" Thick Web; "A" = 2-7/32"
 E-2712	Wagner FE31965	15" x 7"	4595	10-8	E-2713	Wagner for Truck and Bus











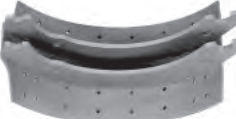

CAM BRAKE SHOES - 16-1/4" DIAMETER BRAKES

UNLINED SHOE NO.	REPLACES	SIZE	FMSI NO.	RIVET	USE BRAKE REPAIR KIT	APPLICATION
 E-3441	Meritor A3722U385	16-1/4" x 3-1/2"	4561	7-7	E-4692	Meritor "T" Brake Front Axle

CAM BRAKE SHOES - 16-1/2" DIAMETER BRAKES

UNLINED SHOE NO.	REPLACES	SIZE	FMSI NO.	RIVET	USE BRAKE REPAIR KIT	APPLICATION
 E-7236	Bendix 2259450	16-1/2" x 7"	4515E	10-8	E-7237	Ford Cargo - Rear Drum Brake
 E-2474	Eaton 805677	16-1/2" x 5"	4223A	10-10	E-3801	Eaton Single Anchor Pin - High Mount (Offset Spring Retainer Pin)
 E-9509	Eaton 805679	16-1/2" x 6"	4317	10-8	E-3801	Eaton Single Anchor Pin - High Mount (Offset Spring Retainer Pin)
 E-1777	Eaton 805678	16-1/2" x 6"	4317G	10-8	E-1887 Series, E-2820	Eaton Single Anchor Pin Tractor and Trailer
 E-1778	Eaton 805442 Eaton 804365	16-1/2" x 7"	4311J	10-8	E-1887 Series, E-2820	Eaton Single Anchor Pin Tractor and Trailer
 E-2819	Eaton 805460 Eaton 1001955	16-1/2" x 7"	4311J	10-8	E-3801	Eaton Single Anchor Pin - High Mount (Offset Spring Retainer Pin)

CAM BRAKE SHOES - 16-1/2" DIAMETER BRAKES

UNLINED SHOE NO.	REPLACES	SIZE	FMSI NO.	RIVET	USE BRAKE REPAIR KIT	APPLICATION
 E-9054	Eaton 805682	16-1/2" x 8-5/8"	4674	10-8	E-1887 Series	Eaton Single Anchor Pin Tractor and Trailer
 E-8922	Eaton ES807799	16-1/2" x 7"	4708	10-9	E-8923	Eaton Top Spec "ES" For Fruehauf "XEM" Brake
 E-8924	Eaton ES807772	16-1/2" x 7"	4708	10-9	E-8925	Eaton Top Spec "ES" For Meritor "Q" Brake (not for Meritor Q Plus™)
 E-9040	Eaton 810214	16-1/2" x 7"	4708	10-10	E-9048	Eaton "ES" Severe Service - Cast Iron
 E-5480	Eaton 806229	16-1/2" x 7"	4709	10-9	E-5481A	Eaton "ES" "Extended Service" Brake
 E-10270	Eaton 819705	16-1/2" x 5"	4719	10-9	E-10760	Eaton "ES II" Brake. Mfg. Stamping No.: 819700 (Web)
 E-10271	Eaton 819706	16-1/2" x 6"	4725	10-9	E-10760	
 E-10272	Eaton 819707	16-1/2" x 7"	4709	10-9	E-10244	
 E-10273	Eaton 819784 Eaton 819708	16-1/2" x 8-5/8"	4726	10-9	E-10244	
 E-3920	Fruehauf ACF-003379-001	16-1/2" x 7"	4515E	10-8	E-3710 Series, E-3895 Series	Fruehauf Current Design "XEM"
 E-2685	Fruehauf ACE-006184-001 Fruehauf 514958-001 Fruehauf 514961-900	16-1/2" x 7"	4515E	10-8	KIT-5, E-2121 Series, E-1816 Series	Fruehauf
 E-3713	Fruehauf ACF-003380-001	16-1/2" x 8-5/8"	4551E	10-8	E-3710 Series, E-3895 Series	Fruehauf Current Design "XEM" Offset - LH
 E-3714	Fruehauf ACF-003380-002	16-1/2" x 8-5/8"	4551E	10-8	E-3710 Series, E-3895 Series	Fruehauf Current Design "XEM" Offset - RH

E-3713LH E-3714RH

CAM BRAKE SHOES - 16-1/2" DIAMETER BRAKES

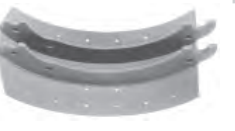



UNLINED SHOE NO.		REPLACES	SIZE	FMSI NO.	RIVET	USE BRAKE REPAIR KIT	APPLICATION
E-6075	Meritor	A3222N1496	16-1/2" x 7"	4515E	10-8	E-2769 Series, E-3895 Series, E-6999 Series	Meritor for Fruehauf "XEM" Brake. Mfg. Stamping No.: F5 (Web)
E-2686	Meritor	A3722B80	16-1/2" x 4"	4549C	10-8	KIT-4 Series, E-1816 Series	Meritor "P" Brake Front Axle
E-2687	Meritor	A3722D82	16-1/2" x 5"	4524B	10-8	KIT-4 Series, E-1816 Series	Meritor "P" Brake Front Axle
E-2684	Meritor	A3722L64	16-1/2" x 6"	4514G	10-9	KIT-4 Series, E-1816 Series	Meritor "P" Brake for Tractor and Trailer
	Meritor	A3222X1142					
E-2241	Meritor	A3722N66	16-1/2" x 7"	4515E	10-8	KIT-4 Series, E-1816 Series	Meritor "P" Brake for Tractor and Trailer
E-5239	Meritor	A3222L1572	16-1/2" x 8-5/8"	4551E	10-8	KIT-4 Series, E-1816 Series	Meritor "P" Brake for Tractor and Trailer
E-3303	Meritor	A3222E1383	16-1/2" x 5"	4524B	10-8	E-2769 Series, E-3895 Series, E-6999 Series	Meritor "Q" Brake Mfg. Stamping No.: 3222-Q-1291 (Web)
E-3823	Meritor	A3222J1440	16-1/2" x 5"	4524B	10-8	E-9644, E-9644 (Contains E-9643 offset-center bar spring)	Meritor "Q" Brake Special for Mack. Relocated Return Spring. Mfg. Stamping No.: 3222-U-1347 (Web)
E-3304	Meritor	A3222C1381	16-1/2" x 6"	4514G	10-8	E-2769 Series, E-3895 Series, E-6999 Series	Meritor "Q" Brake
E-9780	Meritor	A3222V1348	16-1/2" x 6"	4514G	10-8	E-9644 E-9644 (Contains E-9643 offset-center bar spring)	Meritor "Q" Brake Special for Mack. Relocated Return Spring. Mfg. Stamping No.: 3222-U-1347 (Web)
E-5092	Meritor	A3222S1735	16-1/2" x 7"	4515H	10-8	E-5086	Meritor "Q" Brake with 3/8" Thick Web
E-3522	Meritor	A3222T1346	16-1/2" x 8-5/8"	4551B	10-8	E-2769 Series, E-3895 Series, E-6999 Series	Meritor "Q" Brake
E-3417	Meritor	A3222D1356	16-1/2" x 10"	4514G, 4549C	10-8	E-2769 Series, E-3895 Series, E-6999 Series	Meritor "Q" Brake





CAM BRAKE SHOES - 16-1/2" DIAMETER BRAKES

UNLINED SHOE NO.	REPLACES	SIZE	FMSI NO.	RIVET	USE BRAKE REPAIR KIT	APPLICATION
 E-10854	Meritor A3222Z2288	16-1/2" x 5"	4720	10-9	E-9644	Meritor Q Plus™ Brake. NOTE: Euclid recommends using only Heavy-Duty Return Springs with Q Plus™ Brakes.
E-10847	Meritor A3222P2200	16-1/2" x 6"	4715	10-9	E-9644	Meritor Q Plus™ Brake. NOTE: Euclid recommends using only Heavy-Duty Return Springs with Q Plus™ Brakes.
E-5503	Meritor A3222D2006	16-1/2" x 7"	4707	10-9	E-2769 Series	Meritor Q Plus™ Brake. NOTE: Euclid recommends using only Heavy-Duty Return Springs with Q Plus™ Brakes.
E-10850	Meritor A3222J2272	16-1/2" x 8"	4718	10-9	E-2769 Series	Meritor Q Plus™ Brake. NOTE: Euclid recommends using only Heavy-Duty Return Springs with Q Plus™ Brakes.
E-10844	Meritor A3222K2169	16-1/2" x 8-5/8"	4711	10-9	E-2769 Series	Meritor Q Plus™ Brake. NOTE: Euclid recommends using only Heavy-Duty Return Springs with Q Plus™ Brakes.
E-2778	Meritor A91-3222S1293 Meritor A3222S1293 Spicer M16WS103X Fruehauf ACF04362-001	16-1/2" x 7"	4515E Meritor, 4701 Spicer	10-8 Meritor, 10-9 Spicer	E-2769 Series, E-3895 Series, E-6999 Series Meritor Appl. E-5515 Spicer Applications	Meritor "Q" Brake. Spicer "XL" "Xtralife" Brake.



CAM BRAKE SHOES - 18" DIAMETER BRAKES

UNLINED SHOE NO.	REPLACES	SIZE	FMSI NO.	RIVET	USE BRAKE REPAIR KIT	APPLICATION
 E-2801	Eaton 1003017	18" x 7"	4527B		E-2821	Eaton Single Anchor Pin Mack, Navistar - Cast Iron
 E-4902	Meritor A1-3222B1952	18" x 7"	4471B	10-10	E-3992	Meritor - Cast Iron
 E-5500	Spicer M16WS100X Standard Forge 201144	18" x 7"	4284		E-5499	Spicer and Std. Forge

BRAKE SPIDERS - TRAILERS ONLY

EUCLID NO.	REPLACES	PILOT DIA.	BOLT CIRCLE DIA.	HOLE DIA.	NO. OF MTG. HOLES	APPLICATION AND GENERAL INFORMATION
	Dayton/Batco 02125	5-5/8"				Brake Spider for 12-1/4" Brakes. For Std. Forge Axles not drilled for Dust Shields. INCLUDES: E-759 Bushing and E-1416 Seal. No longer includes Anchor Bolt
	Standard Forge 200999002					
	Trailmobile 21L438					
	Dana/Spicer 361653					
	Trailmobile 381108					
	Haldex 66561					
Meritor R001108						
	Kit contains:					Brake Spider and Flange Mounting Kit for 16-1/2" Brakes. For Meritor Standard TK500 Series and Eaton 18,000 lb. Axles. Also Std. Forge 17,000 and 18,000 lb. Axles.
	1 E-957 Brake Spider					
	1 E864 Brake Flange					Bolt-On Spider Assembly for 16-1/2" Brakes. Easy Anchor Pin Removal and Replacement. Prevents Bending of Spiders Caused by Driving Out Frozen Anchor Pins. Allows Adjustment for Wear. INCLUDES: E-1416 Seal and E-759 Bushing
	16 E-632 Spider Mounting Bolts & Nuts					
	Dayton/Batco 02132	5-5/8"	6-5/8"	1/2"	16	Bolt-On Spider Assembly for 16-1/2" Brakes. Easy Anchor Pin Removal and Replacement. Prevents Bending of Spiders Caused by Driving Out Frozen Anchor Pins. Allows Adjustment for Wear. INCLUDES: E-1416 Seal and E-759 Bushing
	Dayton/Batco 02136					
	Standard Forge 200999010					
	Dana/Spicer 361645					
	Dana/Spicer 361647					
	Trailmobile 38957					
	Haldex 65363					
	Trailmobile 700723					
	Trailmobile 7A13					
	Meritor A3211A833					
	Eaton B15931					
Leland L517						
Dana/Spicer M16WS135X						

BRAKE AND AXLE PARTS

EUCLID NO.	REPLACES	PILOT DIA.	BOLT CIRCLE DIA.	HOLE DIA.	NO. OF MTG. HOLES	APPLICATION AND GENERAL INFORMATION
	Dayton/Batco 02400	5-1/8"	6-5/8"	1/2"	16	Brake Flange for 5" Dia. Axles
	Standard Forge 102102002					
	Dana/Spicer 6261					
	Eaton B13231					
	Leland L441					
	Dana/Spicer M16TF101					
	Meritor R00864					
	Dana/Spicer 361657	1/2"			1-13/16"	Brake Spider Mounting Bolt and Nut. Grade 8. Saves valuable time when replacing Spider Bolt and Nut. Made from Alloy Steel and Hardened for Super Strength.
	Trailmobile 38632					
	Leland L219					
	Meritor R00632					

DUST SHIELDS

FOR MERITOR TRAILER APPLICATIONS WITH FABRICATED STEEL SPIDERS

1 PIECE SET

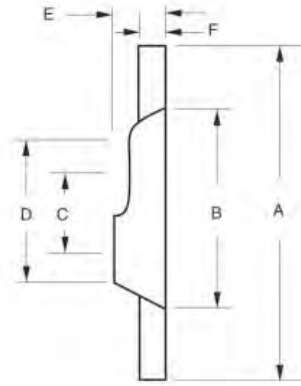

BRAKE SIZE	EUCLID NO.	REPLACES	A	B	C	D	E	F
16-1/2" x 6"	E-9095AHD ¹	Dayton/Batco 02515	18-1/4"	14-3/8"	5-1/4"	11"	2-3/4"	5/8"
16-1/2" x 7"	E-9095A	Leland L3160			5-3/4"			
		Meritor R009095						

DUST SHIELD MOUNTING KIT FOR MERITOR FABRICATED STEEL SPIDERS



EUCLID NO.	INCLUDES	REMARKS
E-10243	1 ABS Grommet 2 Dust Plugs 4 Dust Spacers 4 Mounting Screws	For use with E-9095 Dust Shield. Services one Dust Shield. Torque spec 25-35 ft.lb.

¹ Includes Spacers

DUST SHIELDS

FOR MULTI-PURPOSE TRAILER APPLICATIONS

1 PIECE



E-886
STEEL
16 Gage



E-3775
PLASTIC
Space age nylon plastic is corrosion-resistant and 3.5 lbs. lighter than steel dust shield

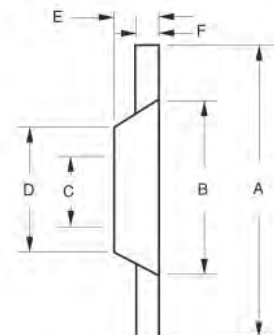

BRAKE SIZE	EUCLID NO.	TYPE	REPLACES	A	B	C	D	E	F	
16-1/2" x 6", 16-1/2" x 7"	E-3775	Plastic Version of E-886	Dayton/Batco 02507							
			Dayton/Batco 02508							
			Standard Forge 211102001							
			Meritor 3236A1249							
			Meritor 3236B1250							
			Dana/Spicer 331499							
			Trailmobile 383775							
			Fruehauf 966691							
			Fruehauf 966692		18-1/4"	14-3/8"	7-13/16"	10"	3"	5/8"
			Meritor A13236A1249							
			Eaton B1688A							
			Leland L3182							
			Leland L556							
			Leland L738							
			Dana/Spicer M16WB101							
			Standard Forge UB1165							
			Standard Forge UB1172							
Standard Forge UB5102										
16-1/2" x 6", 16-1/2" x 7"	E-886	Steel – 16 Gage	Dayton/Batco 02507							
			Dayton/Batco 02508							
			Standard Forge 211102001							
			Meritor 3236A1249							
			Meritor 3236B1250							
			Dana/Spicer 331477							
			Dana/Spicer 331478							
			Trailmobile 38886							
			Trailmobile 7A251							
			Fruehauf 966691							
			Fruehauf 966692		18-1/4"	14-3/8"	7-13/16"	10"	3"	5/8"
			Meritor A13236A1249							
			Eaton B1688A							
			Navistar IT331476							
			Navistar IT331476A							
			Leland L556							
			Leland L738							
Dana/Spicer M16WB100										
Dana/Spicer M16WB101										
Standard Forge UB1165										
Standard Forge UB1172										
Standard Forge UB5102										

DUST SHIELDS

FOR "STOPMASTER" WEDGE BRAKE - TRUCK/TRACTOR APPLICATION

2 PIECE SET

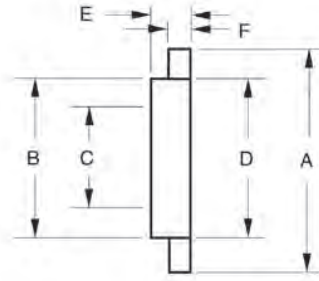

BRAKE SIZE	EUCLID NO.	REPLACES	A	B	C	D	E	F
15" x 7"	E-2735A	Meritor 3736M793 Meritor 3736N326	17"	12-3/4"	10-15/32"	12-5/8"	2.187"	1/2"

FOR EATON BRAKES - TRUCK/TRACTOR APPLICATION WITH CAST SPIDERS

2 PIECE SET

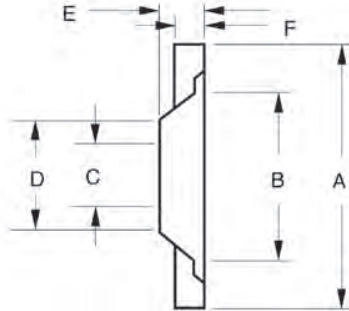

BRAKE SIZE	EUCLID NO.	REPLACES	A	B	C	D	E	F
16-1/2" x 7"	E-2807	Eaton 1000462 Eaton 1000463 Dana/Spicer 331493 Trailmobile 382807 Eaton 79933 Eaton 809713	18-1/4"	11-5/8"	9-15/16"	11-1/2"	1-1/4"	5/8"

FOR MERITOR "P" BRAKES

2 PIECE

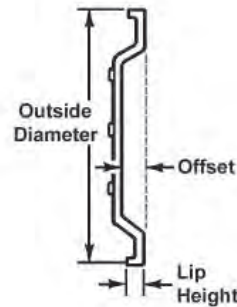

BRAKE SIZE	EUCLID NO.	REPLACES	OUTER DIA.	INNER DIA.	OFFSET	LIP HEIGHT
16-1/2" x 7"	E-11939	Meritor A3736W907	18-1/8"	8-15/16"	1-5/8"	9/16"
16-1/2" x 6"	E-11941	Meritor A13264J114	18-1/8"	9-7/8"	3/4"	2-1/32"
	E-11942 ¹	Meritor A43264T228	18-1/8"	10-11/16"	1-1/4"	17/64"
18"	E-11943	Meritor A13236C1823	19-5/8"	10-1/8"	3/4"	2-1/32"

¹ Includes Spacers

DUST SHIELDS

FOR MERITOR "Q" BRAKES

1 PIECE

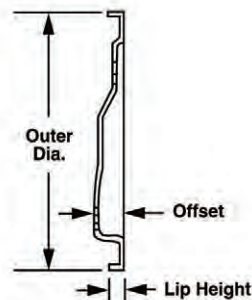
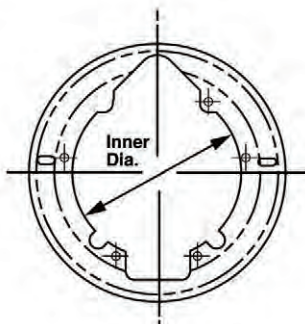

BRAKE SIZE	EUCLID NO.	REPLACES	OUTER DIA.	INNER DIA.	OFFSET	LIP HEIGHT
15" x 4"	E-11934	Meritor 3264E1279	16-7/8"	10-3/16"	1-15/32"	15/16"

FOR MERITOR "Q PLUS" BRAKES

1 PIECE

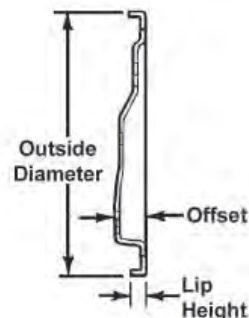

BRAKE SIZE	EUCLID NO.	REPLACES	OUTER DIA.	INNER DIA.	OFFSET	LIP HEIGHT
15" x 4"	E-11935	Meritor 3264R1292	16-9/16"	10-1/2"	1-5/32"	39/64"

FOR MERITOR "Q PLUS" BRAKES

2 PIECE

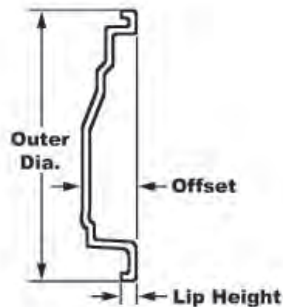

BRAKE SIZE	EUCLID NO.	REPLACES	OUTER DIA.	INNER DIA.	OFFSET	LIP HEIGHT
16-1/2" x 8"	E-11936	Meritor A3264C1381	18-1/8"	9-5/8"	3-13/64"	7/8"
16-1/2" x 7"	E-11937	Meritor A23264P1082	18-1/8"	9-5/8"	2-25/64"	9/16"

1 Includes spacers

DUST SHIELDS

FOR MERITOR "P" AND "Q" BRAKES

2 PIECE

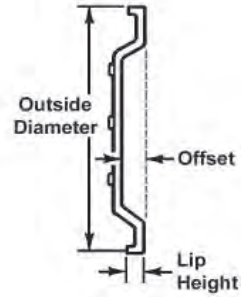
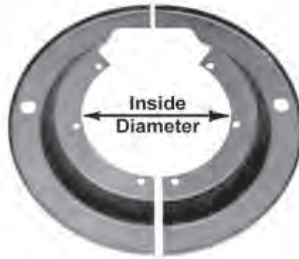

BRAKE SIZE	EUCLID NO.	REPLACES	OUTER DIA.	INNER DIA.	OFFSET	LIP HEIGHT
16-1/2" x 5", 16-1/2" x 6"	E-11938	Meritor A3264S227	18-1/8"	10-11/16"	1-1/4"	17/64"
16-1/2" x 5", 16-1/2" x 7"	E-11940	Meritor A13236Q2123	18-1/8"	10-1/8"	1-1/2"	21/32"

FOR INTRAAX®, VANTRAAX® AND TRAILER AXLES



BRAKE SIZE	EUCLID NO.	REPLACES	OUTER DIA.	INNER DIA.	OFFSET	LIP HEIGHT
16-1/2" x 5"	E-11907	Hendrickson S-28500-1650	18-7/16"	5-1/8"		

Visit us today at
XpresswayPlus.com

1.1



- 🖱 Place your order
- 🖱 Check Price and Availability
- 🖱 Retrieve Invoices
- 🖱 and more!

BRAKE CAMSHAFTS for Tractors and Trailers

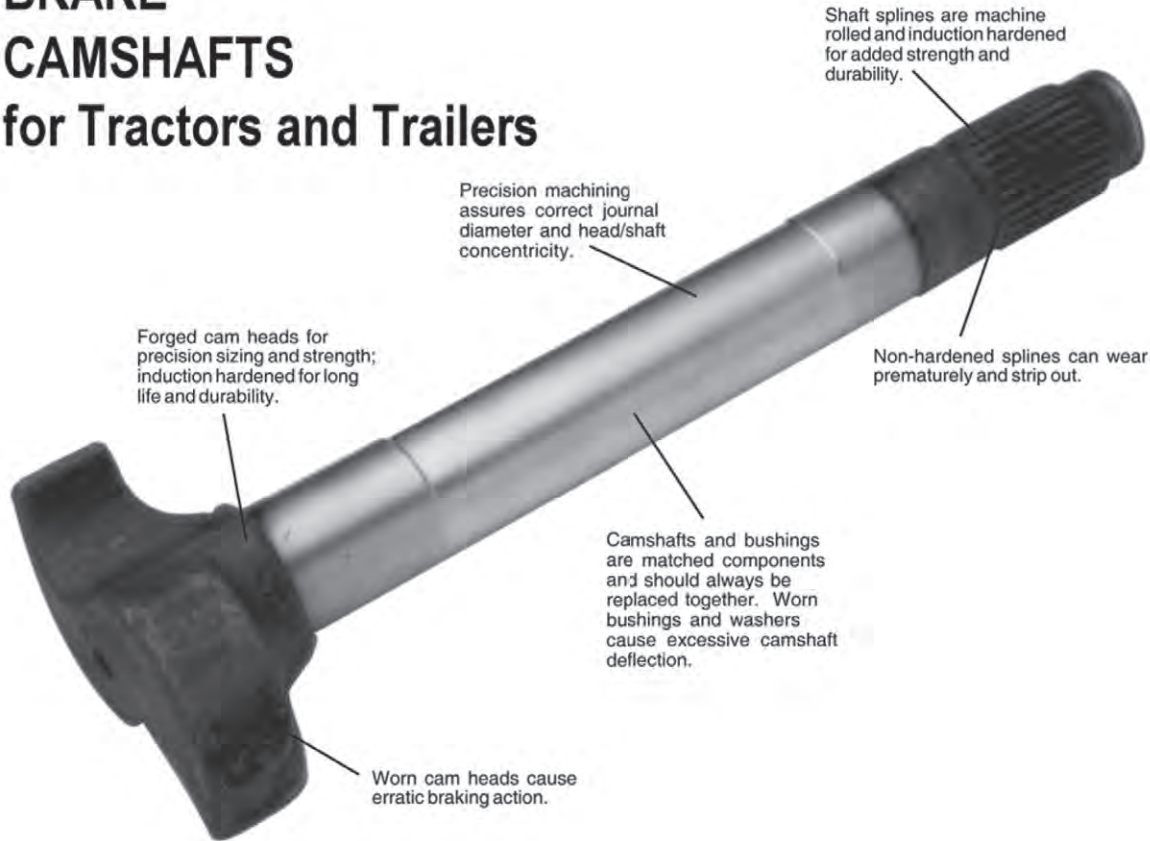

TOUGH... DURABLE... RELIABLE

As the heart of the foundation air brake system, the brake camshaft must be designed and manufactured to meet the demands of today's harder working heavy-duty brakes.

State-of-the-art technology is utilized to manufacture all Euclid brake camshafts. From computer numerically controlled (CNC) turret lathes to computer controlled heat treating equipment, genuine Euclid camshafts are made tough, durable and reliable.

STATE-OF-THE-ART MANUFACTURING

The first step in manufacturing a quality camshaft is forging the head to the correct shape and size.

Next, the shaft is machined "on centers" using computer controlled turret lathes. This guarantees accurate sizing of the bearing journals and cam head/shaft concentricity.

Finally, the shaft splines (28 and 37 tooth) are machine rolled, not broached, for greater strength and dimensional integrity.

To ensure the quality of the finished product, statistical process control (SPC) is utilized in each stage of the manufacturing process.

HEAT TREATING PROVIDES THE FINISHING TOUCH

Heat treating is essential to long-term camshaft performance. Therefore, critical areas, such as the cam head and shaft splines, are induction hardened to prevent accelerated wear and premature failure.

COMPLETE THE JOB WITH GENUINE EUCLID CAMSHAFT REPAIR KITS

Restoring your truck, tractor or trailer brakes to their OEM performance level requires more than a new camshaft. The bushings, washers, seals and lock rings should also be replaced to complete the job.



How to use this Euclid E.S.P. Guide

1. Measure Camshaft Length. All Euclid Camshaft Lengths are measured from **under the camshaft head to the beginning of the lock ring groove.**

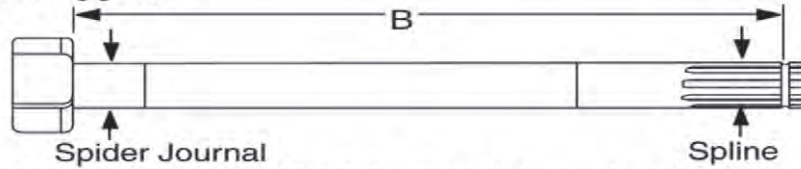

2. Locate approximate camshaft length in guide (Camshafts are listed in order of length, from shortest to longest).
3. After finding camshafts in the approximate length area, determine Camshaft Head Type, using Head Type photos and Head Width Dimensions.
4. Narrow your final selection by Spline, Journal Diameter, and any other notes listed.

Note 1 - Meritor Trailer Camshaft Journal Length and Hardware Selection

With the two different Meritor trailer camshaft journals, care must be taken to match the camshaft with the correct journal length (from under head to first snap ring groove) to the proper hardware. If the proper hardware is not used with these camshafts, damage can occur to foundation brake components, resulting in possible brake failure. Camshafts with the 2 5/64" journal length will work in all applications, but E-9075 Spacers will be needed with certain spiders (see table below).

SPIDER TYPE	JOURNAL LGTH.	E-9075 NEEDED?	CAMSHAFT REPAIR KIT
Cast or Fabricated with Weld-on Bushing Retainer	1 25/32"	NO	E-3520A, E-3520AHD, E-3989AHD, or E-9078HD
	2 5/64"	YES	E-9078HD (contains E-9075 Spacers)
Fabricated with Bolt-on Bushing	2 5/64"	NO	E-9079HD (contains E-6076 Bolt-on Bushings)

Note 2 - Spicer (Dana) 12 1/4" Camshaft, Brake Shoe and Hardware Selection

The two current Spicer 12 1/4" camshaft designs that Euclid offers are the Standard head (Type 3 on E.S.P. Guide), and the second design "Fast-Rise" head, with "0794" OE head marking (Type 5 on E.S.P. Guide). Below is application information on these two camshaft series, along with the associated Euclid Brake Shoe and Repair Kit part numbers required.

The first design "Fast-Rise", with "M12" OE head marking (part numbers E-6083 through E-6100), have been discontinued by Spicer and Euclid. Standard and first design "Fast-Rise" camshafts can be replaced in pairs with second design "Fast-Rise" when using the correct shoe and roller (see below). Do not mix standard, first design or second design "Fast-Rise" camshafts on a single or tandem axle.

SHOE TYPE USED	EUCLID PART NO.	SHOE WIDTH	FMSI	BRAKE REPAIR KIT	ROLLER PART NO.	ROLLER DIAMETER	ROLLER DESIGN	CAMSHAFT DESIGN
Cast	E-1412A E-1413A	5 1/2" 7 1/2"	4544 4607	E-2030HD	E-2176	1 1/4"	2 Piece	Standard
Fabricated "Severe Service" (Closed Roller End)	E-2393 E-2394	5 1/2" 7 1/2"	4536B 4591	E-2402HD E-2403HD*	E-2395	1 1/2"	2 Piece	Standard
Fabricated "Standard Version" (Open Roller End)	E-2393A E-2394A	5 1/2" 7 1/2"	4536E 4692	E-3373HD E-3374HD* E-9281 E-9282*	E-2177 E-586	1 1/4" 1 1/2"	1 Piece 1 Piece	Standard "Fast-Rise" (0794)
Fabricated "U" (Open Roller End)	E-5303A	7 1/2"	4692	E-3782 E-9283	E-2177 E-586	1 1/4" 1 1/2"	1 Piece 1 Piece	Standard "Fast-Rise" (0794)

* Conversion Brake Repair Kits to install fabricated shoes on bolt-on spiders, in place of cast shoes

"Extended Life" Camshafts

Euclid's "Extended Life" descriptions apply to Meritor's "Q Plus", Spicer Dana's "Xtralife", and Eaton's "ES". For look-up purposes, Euclid groups these 16 1/2" versions together. Meritor "Q Plus", Dana "Xtralife", and Eaton "ES" are registered trademarks.

When retrofitting from standard head to "Extended Life" camshafts, Euclid strongly recommends replacing both camshafts on a single axle or all camshafts on a tandem axle to promote a balanced brake condition. To retrofit standard or first design "Fast-Rise" Spicer 12 1/4" camshafts, see **Note 2**, above.

Meritor 16 1/2" Steer Axle "Hammer Claw" Camshaft Replacement

To replace Meritor's discontinued "Hammer Claw" camshafts on 16 1/2" steer axle brakes, use the same length "Q Plus" camshaft and the E-9643 offset-center bar return spring (Brake Repair Kit E-9644). The spring must be installed with the end hooks open toward the camshaft head. The E-9643 return spring can also service the "Hammer Claw" camshaft.

EUCLID CAMSHAFT E.S.P. GUIDE

Listed by Camshaft Length from under head to beginning of lock ring groove.

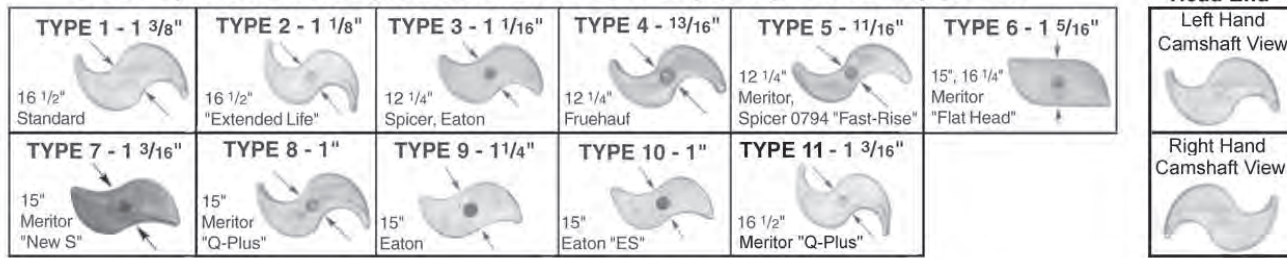

Camshaft Head photos are for identification purposes only — Actual camshaft head may vary slightly in dimension or appearance.

LENGTH	HEAD TYPE	SPLINE	JRNL. DIA.	EUCLID NO.	HEAD END*	AXLE	CAMSHAFT KIT	MFR./BRAKE SIZE	NOTES
5-13/64"	1	1-1/2"-10	1-1/2"	E-10895 E-10896	LH RH	S	E-2086B	Meritor 14-1/2" W	"W" Series Cam Brake
5-3/8"	1	1-1/2"-10	1-1/2"	E-10863 E-10864	LH RH	S	E-2086B	Meritor 14-1/2" W	"W" Series Cam Brake
6-13/64"	11	1-1/2"-28	1-1/2"	E-11513 E-11512	LH RH	D	E-3993B	Meritor 16-1/2" Q Plus	
6-1/4"	1	1-1/2"-10	1-1/2"	E-10859 E-10860	LH RH	D	E-2086B	Meritor 14-1/2" W	"W" Series Cam Brake
6-13/32"	11	1-1/2"-10	1-1/2"	E-4705B E-4704B	LH RH	D	E-3993B	Meritor 16-1/2" Q Plus	
7-3/32"	11	1-1/2"-28	1-1/2"	E-11515 E-11514	LH RH	D	E-3993B	Meritor 16-1/2" Q Plus	
7-13/32"	1	1-1/2"-10	1-1/2"	E-4892 E-4893	LH RH	T	See Camshaft pages	Multi-App 16-1/2"	Single Groove Journal
7-9/16"	6	1-1/2"-10	1-1/2"	E-1090 E-1089	LH RH	S	E-3468A	Meritor 15", 16-1/4" T	
7-5/8"	9	1-1/4"-10	1-1/4"	E-5058 E-5059	LH RH	S	E-5140	Eaton 15"	
7-21/32"	7	1-1/4"-10	1-1/4"	E-9693 E-9694	LH RH	S	E-3446(T), E-3876(Q)	Meritor 15" Q, T	
7-21/32"	6	1-1/4"-10	1-1/4"	E-4912 E-4913	LH RH	S	E-3446	Meritor 15" T	
7-23/32"	11	1-1/2"-28	1-1/2"	E-9645 E-9646	LH RH	D	E-3993B	Meritor 16-1/2" Q Plus	E-5094A (Mack App.), E-9090 (2-1/2" Offset Spider)
7-13/16"	7	1-1/4"-24	1-1/4"	E-9713 E-9714	LH RH	S	E-3876	Meritor 15" Q	2-1/4" Head Length
7-27/32"	1	1-1/2"-10	1-1/2"	E-10862 E-10861	LH RH	D	E-2086B	Meritor 14-1/2" W	"W" Series Cam Brake
7-29/32"	11	1-1/2"-10	1-1/2"	E-4707B E-4706B	LH RH	D	E-3993B	Meritor 16-1/2" Q Plus	
7-15/16"	9	1-1/4"-10	1-1/4"	E-5129 E-5130	LH RH	S	E-5140	Eaton 15"	
7-15/16"	10	1-1/4"-10	1-1/4"	E-9028 E-9029	LH RH	S	E-5140	Eaton 15" ES	
7-15/16"	7	1-1/4"-10	1-1/4"	E-9695 E-9696	LH RH	S	E-3446(T), E-3876(Q)	Meritor 15" Q, T	
7-15/16"	6	1-1/4"-10	1-1/4"	E-3460 E-3461	LH RH	S	E-3446	Meritor 15" T	
8-1/16"	1	1-1/2"-10	1-1/2"	E-5057 E-5056	LH RH	D	E-2086B (P), E-3993B (Q)	Meritor 16-1/2" P and Q	Lock Ring End Dia. - 1-1/2"
8-1/16"	11	1-1/2"-28	1-1/2"	E-9647 E-9648	LH RH	D	E-3993B	Meritor 16-1/2" Q Plus	E-5094A (Mack App.), E-9090 (2-1/2" Offset Spider)
8-13/64"	11	1-1/2"-28	1-1/2"	E-11517 E-11516	LH RH	D	E-3993B	Meritor 16-1/2" Q Plus	
8-5/16"	11	1-1/2"-28	1-1/2"	E-11519 E-11518	LH RH	D	E-3993B	Meritor 16-1/2" Q Plus	
8-29/64"	8	1-1/2"-28	1-1/2"	E-11520 E-11521	LH RH	S	E-3993B	Meritor 15" Q Plus	
8-15/32"	6	1-1/4"-10	1-1/4"	E-4916 E-4917	LH RH	S	E-3446	Meritor 15" T	

*Left or Right Hand description refers to the rotation of the Camshaft Head. This description does not always match the position of the Camshaft on the axle.
 AXLE = S-Steering; D-Drive; T-Trailer

EUCLID CAMSHAFT E.S.P. GUIDE

Listed by Camshaft Length from under head to beginning of lock ring groove.

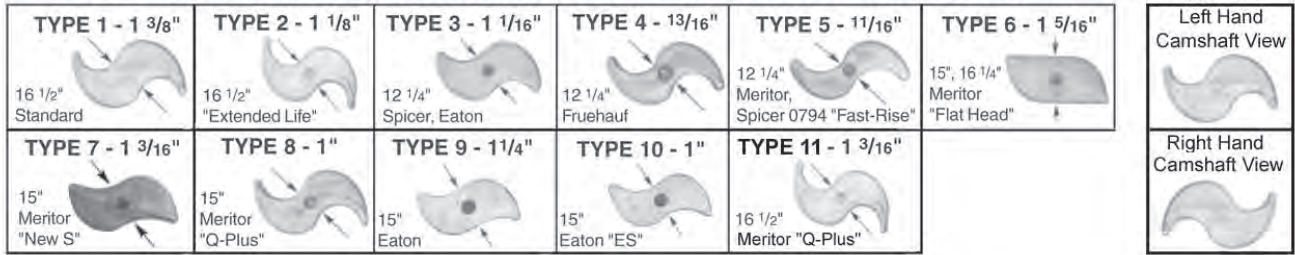

Camshaft Head photos are for identification purposes only — Actual camshaft head may vary slightly in dimension or appearance.

LENGTH	HEAD TYPE	SPLINE	JRNL. DIA.	EUCLID NO.	HEAD END*	AXLE	CAMSHAFT KIT	MFR./BRAKE SIZE	NOTES
8-1/2"	7	1-1/4"-10	1-1/4"	E-9697 E-9698	LH RH	S	E-3446(T), E-3876(Q)	Meritor 15" Q, T	
8-1/2"	7	1-1/4"-24	1-1/4"	E-9707 E-9708	LH RH	S	E-3876	Meritor 15" Q	1-3/4" Head Length
8-1/2"	6	1-1/2"-10	1-1/2"	E-4991 E-4992	LH RH	S	E-3468A	Meritor 15" , 16-1/4" T	
8-35/64"	8	1-1/2"-10	1-1/2"	E-2479B E-2478B	LH RH	D	E-3993B	Meritor 16-1/2" Q Plus	
8-9/16"	9	1-1/4"-10	1-1/4"	E-5060 E-5061	LH RH	S	E-5140	Eaton 15"	
8-9/16"	1	1-1/2"-10	1-1/2"	E-2800 E-2799	LH RH	D	E-2125	Eaton 16-1/2"	Lock Ring End Dia. - 1-1/8"
8-9/16"	11	1-1/2"-28	1-1/2"	E-9649 E-9650	LH RH	D	E-3993B	Meritor 16-1/2" Q Plus	E-5094A (Mack App.), E-9090 (2-1/2" Offset Spider)
8-37/64"	11	1-1/2"-28	1-5/8"	E-11609 E-11608	LH RH	D	E-11904	Meritor 16-1/2" Q Plus	
8-5/8"	2	1-1/2"-10	1-1/2"	E-5490 E-5491	LH RH	D	E-10897	Eaton 15" Reduced Envelope , 16-1/2" ES	Also 15" Red. Env., Lock Ring End Dia. - 1-1/8"
8-21/32"	6	1-1/2"-10	1-1/2"	E-4993 E-4994	LH RH	S	E-3468A	Meritor 15" , 16-1/4" T	
8-45/64"	8	1-1/2"-28	1-1/2"	E-11522 E-11523	LH RH	S	E-3993B	Meritor 15" Q Plus	
8-45/64"	11	1-1/2"-28	1-1/2"	E-11525 E-11524	LH RH	D	E-3993B	Meritor 16-1/2" Q Plus	
8-45/64"	11	1-1/2"-28	1-5/8"	E-11968 E-11969	LH RH	D	E-11904	Meritor 15" Q Plus	
8-7/8"	6	1-1/2"-10	1-1/2"	E-4995 E-4996	LH RH	S	E-3468A	Meritor 15" , 16-1/4" T	
8-15/16"	9	1-1/4"-10	1-1/4"	E-5066 E-5067	LH RH	S	E-5140	Eaton 15"	
9-1/16"	11	1-1/2"-28	1-1/2"	E-9651 E-9652	LH RH	D	E-3993B	Meritor 16-1/2" Q Plus	E-5094A (Mack App.), E-9090 (2-1/2" Offset Spider)
9-1/16"	11	1-1/2"-10	1-1/2"	E-9687A E-9688A	LH RH	D	E-3993B	Meritor 16-1/2" Q Plus	
9-3/16"	9	1-1/4"-10	1-1/4"	E-5131 E-5132	LH RH	S	E-5140	Eaton 15"	
9-3/16"	10	1-1/4"-10	1-1/4"	E-9030 E-9031	LH RH	S	E-5140	Eaton 15" ES	
9-1/4"	7	1-1/4"-10	1-1/4"	E-9699 E-9700	LH RH	S	E-3446(T), E-3876(Q)	Meritor 15" Q, T	
9-1/4"	6	1-1/4"-10	1-1/4"	E-4918 E-4919	LH RH	S	E-3446	Meritor 15" T	
9-1/4"	7	1-1/4"-24	1-1/4"	E-5529 E-5530	LH RH	S	E-3876	Meritor 15" Q	1-3/4" Head Length
9-1/4"	8	1-1/2"-28	1-1/2"	E-9065 E-9066	LH RH	S	E-3993B	Meritor 15" Q Plus	
9-5/16"	11	1-1/2"-28	1-5/8"	E-11611 E-11610	LH RH	D	E-11904	Meritor 16-1/2" Q Plus	

*Left or Right Hand description refers to the rotation of the Camshaft Head. This description does not always match the position of the Camshaft on the axle.
AXLE = S-Steering; D-Drive; T-Trailer

EUCLID CAMSHAFT E.S.P. GUIDE

Listed by Camshaft Length from under head to beginning of lock ring groove.

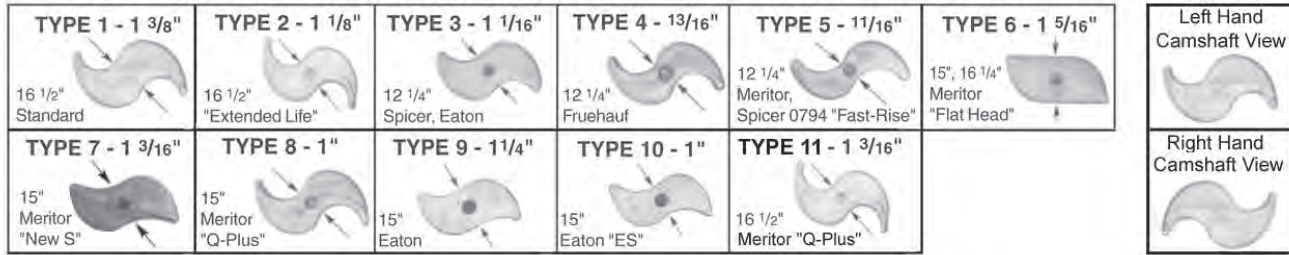

Camshaft Head photos are for identification purposes only — Actual camshaft head may vary slightly in dimension or appearance.

LENGTH	HEAD TYPE	HEAD SPLINE	JRNL. DIA.	EUCLID NO.	HEAD END*	AXLE	CAMSHAFT KIT	MFR./BRAKE SIZE	NOTES
9-5/16"	11	1-1/2"-28	1-1/2"	E-11527 E-11526	LH RH	D	E-3993B	Meritor 16-1/2" Q Plus	
9-13/32"	7	1-1/4"-24	1-1/4"	E-9715 E-9716	LH RH	S	E-3876	Meritor 15" Q	2-1/4" Head Length
9-7/16"	11	1-1/2"-28	1-1/2"	E-9653 E-9654	LH RH	D	E-3993B	Meritor 16-1/2" Q Plus	E-5094A (Mack App.), E-9090 (2-1/2" Offset Spider)
9-29/64"	8	1-1/2"-28	1-1/2"	E-9067A E-9068A	LH RH	S	E-3993B	Meritor 15" Q Plus	
9-9/16"	9	1-1/4"-10	1-1/4"	E-5133 E-5134	LH RH	S	E-5140	Eaton 15"	
9-9/16"	10	1-1/4"-10	1-1/4"	E-9032 E-9033	LH RH	S	E-5140	Eaton 15" ES	
9-9/16"	7	1-1/4"-10	1-1/4"	E-9701 E-9702	LH RH	S	E-3446(T), E-3876(Q)	Meritor 15" Q, T	
9-9/16"	6	1-1/4"-10	1-1/4"	E-4936 E-4937	LH RH	S	E-3446	Meritor 15" T	
9-9/16"	7	1-1/4"-24	1-1/4"	E-9711 E-9712	LH RH	S	E-3876	Meritor 15" Q	1-3/4" Head Length
9-37/64"	11	1-1/2"-28	1-5/8"	E-11613 E-11612	LH RH	D	E-11904	Meritor 16-1/2" Q Plus	
9-45/64"	11	1-1/2"-28	1-1/2"	E-11529 E-11528	LH RH	D	E-3993B	Meritor 16-1/2" Q Plus	
9-25/32"	9	1-1/4"-10	1-1/4"	E-5135 E-5136	LH RH	S	E-5140	Eaton 15"	
9-25/32"	10	1-1/4"-10	1-1/4"	E-9034 E-9035	LH RH	S	E-5140	Eaton 15" ES	
9-13/16"	11	1-1/2"-28	1-1/2"	E-11531 E-11530	LH RH	D	E-3993B	Meritor 16-1/2" Q Plus	
9-61/64"	11	1-1/2"-28	1-1/2"	E-11533 E-11532	LH RH	D	E-3993B	Meritor 16-1/2" Q Plus	
10-1/16"	7	1-1/4"-24	1-1/4"	E-9717 E-9718	LH RH	S	E-3876	Meritor 15" Q	2-1/4" Head Length
10-3/32"	11	1-1/2"-28	1-1/2"	E-11535 E-11534	LH RH	D	E-3993B	Meritor 16-1/2" Q Plus	
10-1/8"	1	1-1/2"-10	1-1/2"	E-1789 E-1788	LH RH	T	See Camshaft pages	Multi-App 16-1/2"	Single Groove Journal
10-5/32"	1	1-1/2"-10	1-1/2"	E-9763 E-9764	LH RH	D	E-2125	Eaton 16-1/2"	Lock Ring End Dia. - 1-1/8"
10-3/16"	11	1-1/2"-28	1-1/2"	E-5504A E-5505A	LH RH	D	E-3993B	Meritor 16-1/2" Q Plus	
10-13/64"	11	1-1/2"-28	1-1/2"	E-11537 E-11536	LH RH	D	E-3993B	Meritor 16-1/2" Q Plus	
10-13/32"	11	1-1/2"-28	1-1/2"	E-9655 E-9656	LH RH	D	E-3993B	Meritor 16-1/2" Q Plus	E-5094A (Mack App.), E-9090 (2-1/2" Offset Spider)
10-1/2"	1	1-1/2"-10	1-1/2"	E-4886 E-4887	LH RH	D	E-2125	Eaton 16-1/2"	Lock Ring End Dia. - 1-1/8"
10-33/64"	11	1-1/2"-10	1-1/2"	E-2701B E-2700B	LH RH	D	E-3993B	Meritor 16-1/2" Q Plus	
10-33/64"	8	1-1/2"-28	1-1/2"	E-11538 E-11539	LH RH	S	E-3993B	Meritor 15" Q Plus	

*Left or Right Hand description refers to the rotation of the Camshaft Head. This description does not always match the position of the Camshaft on the axle.
AXLE = S-Steering; D-Drive; T-Trailer

EUCLID CAMSHAFT E.S.P. GUIDE

Listed by Camshaft Length from under head to beginning of lock ring groove.

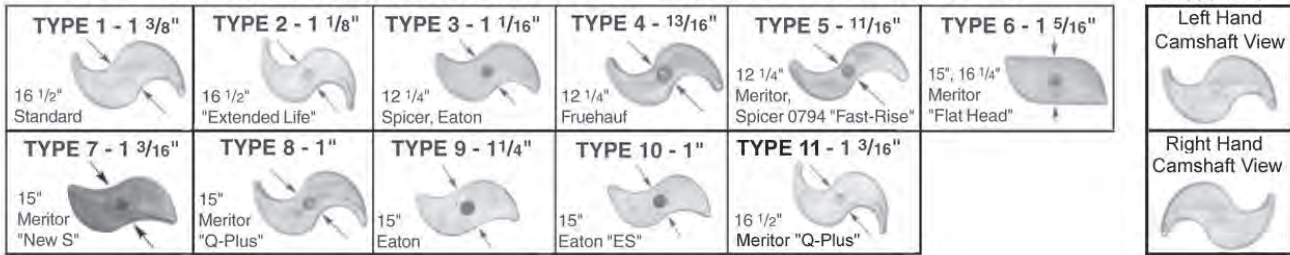

Camshaft Head photos are for identification purposes only — Actual camshaft head may vary slightly in dimension or appearance.

LENGTH	HEAD TYPE	SPLINE	JRNL. DIA.	EUCLID NO.	HEAD END*	AXLE	CAMSHAFT KIT	MFR./BRAKE SIZE	NOTES
10-9/16"	2	1-1/2"-10	1-1/2"	E-9767 E-9768	LH RH	D	E-10897	Eaton 15" Reduced Envelope, 16-1/2" ES	
10-19/32"	11	1-1/2"-28	1-1/2"	E-11541 E-11543	LH RH	D	E-3993B	Meritor 16-1/2" Q Plus	
10-19/32"	11	1-1/2"-28	1-1/2"	E-11542 E-11540	RH RH	D	E-3993B	Meritor 16-1/2" Q Plus	
10-45/64"	11	1-1/2"-28	1-1/2"	E-11545 E-11544	LH RH	D	E-3993B	Meritor 16-1/2" Q Plus	
10-13/16"	11	1-1/2"-28	1-1/2"	E-11547 E-11546	LH RH	D	E-3993B	Meritor 16-1/2" Q Plus	
10-29/32"	9	1-1/4"-10	1-1/4"	E-5062 E-5063	LH RH	S	E-5140	Eaton 15"	
10-15/16"	11	1-1/2"-28	1-1/2"	E-9657 E-9658	LH RH	D	E-3993B	Meritor 16-1/2" Q Plus	E-5094A (Mack App.), E-9090 (2-1/2" Offset Spider)
11-1/32"	2	1-1/2"-10	1-1/2"	E-11864 E-11865	LH RH	T	E-11897, E-11450HD	Hendrickson 16-1/2" Intraax®	
11-1/32"	2	1-1/2"-28	1-1/2"	E-11866 E-11867	LH RH	T	E-11897, E-11450HD	Hendrickson 16-1/2" Intraax®	
11-1/32"	1	1-1/2"-28	1-1/2"	E-10899 E-10900	LH RH	T	E-9791HD	Hendrickson 16-1/2" Intraax®	
11-1/8"	1	1-1/2"-10	1-1/2"	E-9765 E-9766	LH RH	D	E-2125	Eaton 16-1/2"	Lock Ring End Dia. - 1-1/8"
11-1/8"	11	1-1/2"-10	1-1/2"	E-1774C E-1773C	LH RH	D	E-3993B	Meritor 16-1/2" Q Plus	
11-1/8"	11	1-1/2"-28	1-1/2"	E-9659 E-9660	LH RH	D	E-3993B	Meritor 16-1/2" Q Plus	E-5094A (Mack App.), E-9090 (2-1/2" Offset Spider)
11-13/64"	11	1-1/2"-28	1-5/8"	E-11619 E-11618	LH RH	D	E-11904	Meritor 16-1/2" Q Plus	
11-3/8"	8	1-1/2"-28	1-1/2"	E-11548 E-11549	LH RH	S	E-3993B	Meritor 15" Q Plus	
11-1/2"	2	1-1/2"-10	1-1/2"	E-5492 E-5493	LH RH	D	E-10897	Eaton 15" Reduced Envelope, 16-1/2" ES	Lock Ring End Dia. - 1-1/8"
11-1/2"	1	1-1/2"-10	1-1/2"	E-1776 E-1775	LH RH	D	E-2125	Eaton 16-1/2"	Lock Ring End Dia. - 1-1/8"
11-33/64"	11	1-1/2"-10	1-1/2"	E-1148C E-1147C	LH RH	D	E-3993B	Meritor 16-1/2" Q Plus	
11-9/16"	11	1-1/2"-28	1-1/2"	E-9661 E-9662	LH RH	D	E-9080	Meritor 16-1/2" Q Plus	E-5094A (Mack App.), E-9090 (2-1/2" Offset Spider)
11-19/32"	8	1-1/2"-28	1-1/2"	E-11550 E-11551	LH RH	S	E-3993B	Meritor 15" Q Plus	
11-11/16"	11	1-1/2"-10	1-1/2"	E-4703B E-4702B	LH RH	D	E-3993B	Meritor 16-1/2" Q Plus	
11-11/16"	11	1-1/2"-28	1-1/2"	E-9663 E-9664	LH RH	D	E-3993B	Meritor 16-1/2" Q Plus	E-5094A (Mack App.), E-9090 (2-1/2" Offset Spider)
11-45/64"	11	1-1/2"-28	1-5/8"	E-11623 E-11622	LH RH	D	E-11904	Meritor 16-1/2" Q Plus	
11-13/16"	11	1-1/2"-28	1-1/2"	E-11553 E-11552	LH RH	D	E-3993B	Meritor 16-1/2" Q Plus	

*Left or Right Hand description refers to the rotation of the Camshaft Head. This description does not always match the position of the Camshaft on the axle.

AXLE = S-Steering; D-Drive; T-Trailer

EUCLID CAMSHAFT E.S.P. GUIDE

Listed by Camshaft Length from under head to beginning of lock ring groove.

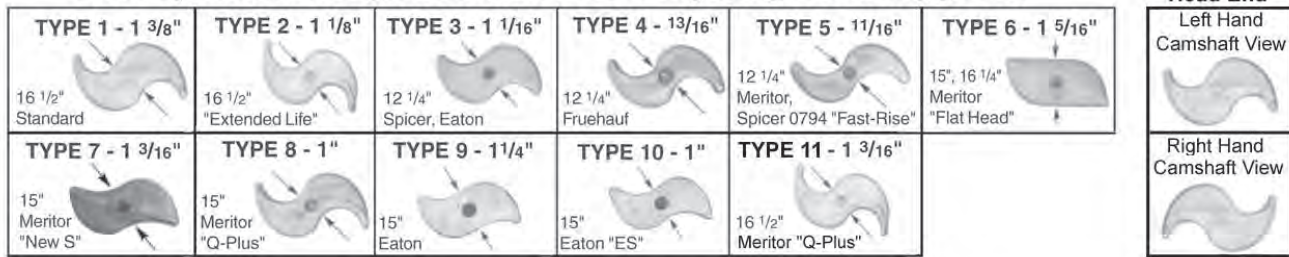

Camshaft Head photos are for identification purposes only — Actual camshaft head may vary slightly in dimension or appearance.

LENGTH	HEAD TYPE	SPLINE	JRNL. DIA.	EUCLID NO.	HEAD END*	AXLE	CAMSHAFT KIT	MFR./BRAKE SIZE	NOTES
11-15/16"	11	1-1/2"-28	1-1/2"	E-9665 E-9666	LH RH	D	E-3993B	Meritor 16-1/2" Q Plus	E-5094A (Mack App.), E-9090 (2-1/2" Offset Spider)
11-61/64"	11	1-1/2"-28	1-5/8"	E-11625 E-11624	LH RH	D	E-11904	Meritor 16-1/2" Q Plus	
12-1/16"	1	1-1/2"-10	1-1/2"	E-2715A E-2714A	LH RH	D	E-2086B (P), E-3993B (Q)	Meritor 16-1/2" P and Q	Lock Ring End Dia. - 1-1/2"
12-13/64"	11	1-1/2"-28	1-1/2"	E-11555 E-11554	LH RH	D	E-3993B	Meritor 16-1/2" Q Plus	
12-5/16"	11	1-1/2"-28	1-1/2"	E-11557 E-11556	LH RH	D	E-3993B	Meritor 16-1/2" Q Plus	
12-7/16"	1	1-1/2"-10	1-1/2"	E-2787 E-2786	LH RH	D	E-2125	Eaton 16-1/2"	Lock Ring End Dia. - 1-1/8"
12-7/16"	11	1-1/2"-28	1-1/2"	E-9667 E-9668	LH RH	D	E-3993B	Meritor 16-1/2" Q Plus	E-5094A (Mack App.), E-9090 (2-1/2" Offset Spider)
12-29/64"	11	1-1/2"-28	1-1/2"	E-11559 E-11558	LH RH	D	E-3993B	Meritor 16-1/2" Q Plus	
12-15/32"	11	1-1/2"-10	1-1/2"	E-4709B E-4708B	LH RH	D	E-3993B	Meritor 16-1/2" Q Plus	
12-1/2"	2	1-1/2"-10	1-1/2"	E-9769 E-9770	LH RH	D	E-10897	Eaton 15" Reduced Envelope, 16-1/2" ES	
12-13/16"	11	1-1/2"-28	1-1/2"	E-11563 E-11562	LH RH	D	E-3993B	Meritor 16-1/2" Q Plus	
12-15/16"	1	1-1/2"-10	1-1/2"	E-4888 E-4889	LH RH	D	E-2125	Eaton 16-1/2"	Lock Ring End Dia. - 1-1/8"
12-15/16"	11	1-1/2"-28	1-1/2"	E-9669 E-9670	LH RH	D	E-3993B	Meritor 16-1/2" Q Plus	
12-61/64"	11	1-1/2"-28	1-5/8"	E-11627 E-11626	LH RH	D	E-11904	Meritor 16-1/2" Q Plus	
13-3/32"	11	1-1/2"-28	1-1/2"	E-11565 E-11564	LH RH	D	E-3993B	Meritor 16-1/2" Q Plus	
13-13/64"	11	1-1/2"-28	1-5/8"	E-11629 E-11628	LH RH	D	E-11904	Meritor 16-1/2" Q Plus	
13-7/32"	11	1-1/2"-28	1-1/2"	E-9671 E-9672	LH RH	D	E-3993B	Meritor 16-1/2" Q Plus	
13-5/16"	8	1-1/2"-28	1-1/2"	E-11567 E-11566	LH RH	S	E-3993B	Meritor 15" Q Plus	
13-7/16"	1	1-1/2"-10	1-1/2"	E-4740 E-4741	LH RH	D	E-2125	Eaton 16-1/2"	Lock Ring End Dia. - 1-1/8"
13-7/16"	11	1-1/2"-28	1-1/2"	E-9673A E-9674A	LH RH	D	E-3993B	Meritor 16-1/2" Q Plus	
13-29/64"	11	1-1/2"-28	1-1/2"	E-4733A E-4732A	LH RH	D	E-3993B	Meritor Q Plus	
13-29/64"	11	1-1/2"-28	1-5/8"	E-11631 E-11630	LH RH	D	E-11904	Meritor 16-1/2" Q Plus	
13-15/32"	2	1-1/2"-10	1-1/2"	E-10911 E-10912	LH RH	D	E-10897	Eaton 16-1/2" ES	Lock Ring End Dia. - 1-1/8"
13-19/32"	11	1-1/2"-28	1-1/2"	E-11569 E-11568	LH RH	D	E-3993B	Meritor 16-1/2" Q Plus	
13-21/32"	11	1-1/2"-10	1-1/2"	E-9689A E-9690A	LH RH	D	E-3993B	Meritor 16-1/2" Q Plus	

*Left or Right Hand description refers to the rotation of the Camshaft Head. This description does not always match the position of the Camshaft on the axle.
AXLE = S-Steering; D-Drive; T-Trailer

EUCLID CAMSHAFT E.S.P. GUIDE

Listed by Camshaft Length from under head to beginning of lock ring groove.

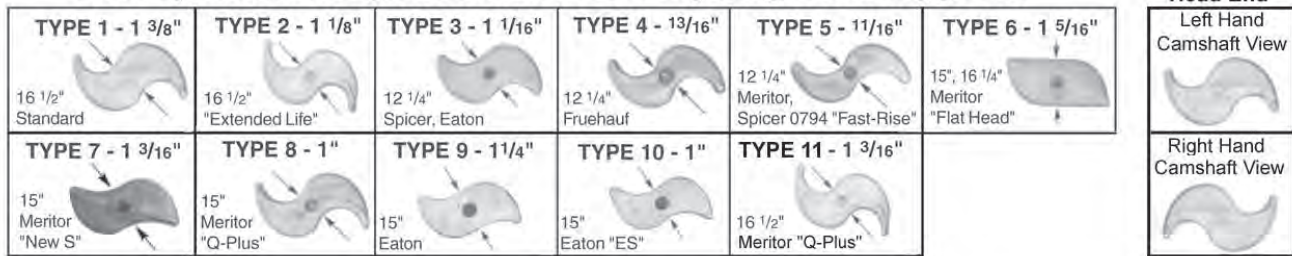

Camshaft Head photos are for identification purposes only — Actual camshaft head may vary slightly in dimension or appearance.

LENGTH	HEAD TYPE	SPLINE	JRNL. DIA.	EUCLID NO.	HEAD END*	AXLE	CAMSHAFT KIT	MFR./BRAKE SIZE	NOTES
13-45/64"	11	1-1/2"-28	1-1/2"	E-4910A	LH	D	E-3993B	Meritor 16-1/2" Q Plus	
				E-4911A	RH				
13-13/16"	11	1-1/2"-28	1-1/2"	E-11571	LH	D	E-3993B	Meritor 16-1/2" Q Plus	
				E-11570	RH				
14-3/32"	11	1-1/2"-28	1-1/2"	E-9675	LH	D	E-3993B	Meritor 16-1/2" Q Plus	
				E-9676	RH				
14-1/4"	1	1-1/2"-10	1-1/2"	E-3523	LH	D	E-2125	Eaton 16-1/2"	Lock Ring End Dia. - 1-1/8"
				E-3524	RH				
14-5/16"	2	1-1/2"-10	1-1/2"	E-9771	LH	D	E-10897	Eaton 15" Reduced Envelope, 16-1/2" ES	
				E-9772	RH				
14-5/16"	11	1-1/2"-28	1-1/2"	E-11573	LH	D	E-3993B	Meritor 16-1/2" Q Plus	
				E-11572	RH				
14-37/64"	11	1-1/2"-28	1-5/8"	E-11633	LH	D	E-11904	Meritor 16-1/2" Q Plus	
				E-11632	RH				
14-19/32"	11	1-1/2"-28	1-1/2"	E-9677	LH	D	E-3993B	Meritor 16-1/2" Q Plus	
				E-9678	RH				
14-45/64"	11	1-1/2"-28	1-1/2"	E-11575	LH	D	E-3993B	Meritor 16-1/2" Q Plus	
				E-11574	RH				
14-3/4"	11	1-1/2"-28	1-1/2"	E-9679	LH	D	E-3993B	Meritor 16-1/2" Q Plus	
				E-9680	RH				
14-7/8"	11	1-1/2"-10	1-1/2"	E-9691A	LH	D	E-3993B	Meritor 16-1/2" Q Plus	
				E-9692A	RH				
14-61/64"	11	1-1/2"-28	1-1/2"	E-11577	LH	D	E-3993B	Meritor 16-1/2" Q Plus	
				E-11576	RH				
15"	1	1-1/2"-10	1-1/2"	E-9055	LH	D	E-2125	Eaton 16-1/2"	Lock Ring End Dia. - 1-1/8"
				E-9056	RH				
15-3/32"	11	1-1/2"-28	1-1/2"	E-11579	LH	D	E-3993B	Meritor 16-1/2" Q Plus	
				E-11581	LH				
15-3/32"	11	1-1/2"-28	1-1/2"	E-11580	RH	D	E-3993B	Meritor 16-1/2" Q Plus	
				E-11578	RH				
15-1/8"	2	1-1/2"-10	1-1/2"	E-10913	LH	D	E-10897	Eaton 16-1/2" ES	Lock Ring End Dia. - 1-1/8"
				E-10914	RH				
15-3/16"	11	1-1/2"-28	1-1/2"	E-9681	LH	D	E-3993B	Meritor 16-1/2" Q Plus	
				E-9682	RH				
15-1/4"	2	1-1/2"-10	1-1/2"	E-10915	LH	D	E-10897	Eaton 16-1/2" ES	Lock Ring End Dia. - 1-1/8"
				E-10916	RH				
15-5/16"	11	1-1/2"-28	1-1/2"	E-11583	LH	D	E-3993B	Meritor 16-1/2" Q Plus	
				E-11582	RH				
15-19/32"	11	1-1/2"-28	1-1/2"	E-10306A	LH	D	E-3993B	Meritor 16-1/2" Q Plus	
				E-10307A	RH				
15-5/8"	11	1-1/2"-10	1-1/2"	E-4711B	LH	D	E-3993B	Meritor 16-1/2" Q Plus	
				E-4710B	RH				
15-5/8"	1	1-1/2"-10	1-1/2"	E-9709	LH	T	E-2287	Spicer 16-1/2"	Single Groove Journal
				E-9710	RH				
15-45/64"	11	1-1/2"-28	1-5/8"	E-11639	LH	D	E-11904	Meritor 16-1/2" Q Plus	
				E-11638	RH				
15-23/32"	11	1-1/2"-28	1-1/2"	E-9683	LH	D	E-3993B	Meritor 16-1/2" Q Plus	
				E-9684	RH				

*Left or Right Hand description refers to the rotation of the Camshaft Head. This description does not always match the position of the Camshaft on the axle.
AXLE = S-Steering; D-Drive; T-Trailer

EUCLID CAMSHAFT E.S.P. GUIDE

Listed by Camshaft Length from under head to beginning of lock ring groove.

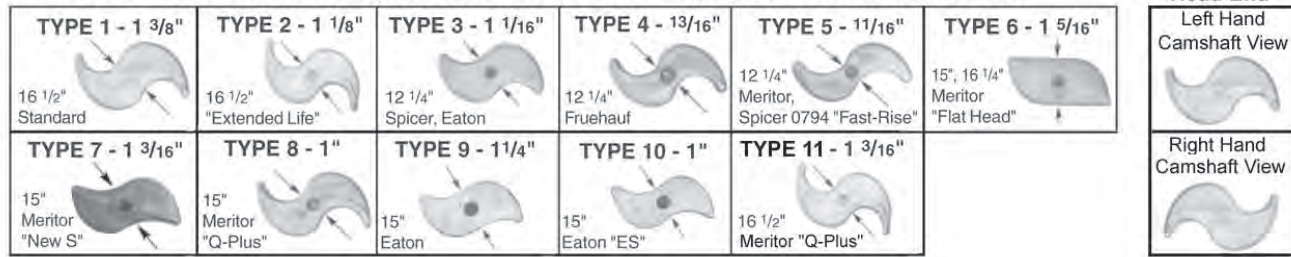

Camshaft Head photos are for identification purposes only — Actual camshaft head may vary slightly in dimension or appearance.

LENGTH	HEAD TYPE	JRN. SPLINE	JRN. DIA.	EUCLID NO.	HEAD END*	AXLE	CAMSHAFT KIT	MFR./BRAKE SIZE	NOTES
15-13/16"	11	1-1/2"-28	1-5/8"	E-11641 E-11640	LH RH	D	E-11904	Meritor 16-1/2" Q Plus	
15-13/16"	11	1-1/2"-28	1-1/2"	E-11585 E-11584	LH RH	D	E-3993B	Meritor 16-1/2" Q Plus	
15-61/64"	11	1-1/2"-28	1-1/2"	E-11587 E-11586	LH RH	D	E-3993B	Meritor 16-1/2" Q Plus	
16-3/32"	11	1-1/2"-28	1-1/2"	E-11589 E-11588	LH RH	D	E-3993B	Meritor 16-1/2" Q Plus	
16-1/8"	5	1-1/2"-10	1-1/2"	E-9263 E-9264 E-9761	LH RH LH	T	E-2469 (Nylon Bushing) E-2090 (Late Model), E-2122 (Early Model)	Spicer 12-1/4"	0794L/R Head Fast-Rise
16-1/8"	1	1-1/2"-28	1-5/8"	E-9762 E-1563	RH LH	T	E-2090 (Late Model), E-2122 (Early Model)	Fruehauf 16-1/2"	
16-1/8"	1	1-5/8"-37	1-5/8"	E-1564	RH	T	E-2090 (Late Model), E-2122 (Early Model)	Fruehauf 16-1/2"	
16-5/16"	1	1-1/2"-10	1-1/2"	E-4713 E-4712	LH RH	T	See Camshaft pages	Multi-App 16-1/2"	Single Groove Journal
16-3/8"	4	1-1/2"-28	1-1/2"	E-10917 E-10918	LH RH	T	E-2469 (Nylon Bushing)	Dexter 12-1/4"	Single Groove Journal
16-29/64"	11	1-1/2"-28	1-1/2"	E-11591 E-11590	LH RH	D	E-3993B	Meritor 16-1/2" Q Plus	
16-1/2"	1	1-1/2"-10	1-1/2"	E-687 E-686	LH RH	T	See Camshaft pages	Multi-App 16-1/2"	Single Groove Journal
16-19/32"	11	1-1/2"-28	1-1/2"	E-11593 E-11592	LH RH	D	E-3993B	Meritor 16-1/2" Q Plus	
16-13/16"	11	1-1/2"-28	1-1/2"	E-11595 E-11594	LH RH	D	E-3993B	Meritor 16-1/2" Q Plus	
16-61/64"	11	1-1/2"-28	1-1/2"	E-11597 E-11596	LH RH	D	E-3993B	Meritor 16-1/2" Q Plus	
17-3/16"	2	1-1/2"-28	1-1/2"	E-9096 E-9097	LH RH	T	E-2287	Spicer 16-1/2" XL	Double Groove Journal - 1-5/8", 2-7/32"
17-5/16"	11	1-1/2"-10	1-5/8"	E-2447A E-2448A	LH RH	T	E-3520A, E-3520AHD	Meritor 16-1/2" Q Plus	
17-5/16"	11	1-1/2"-28	1-5/8"	E-2441B E-2442B	LH RH	T	E-3520A, E-3520AHD	Meritor 16-1/2" P, Q, Q Plus	
17-5/16"	11	1-1/2"-28	1-5/8"	E-5506 E-5507	LH RH	T	E-9078HD (Press-In Bushing), E-9079HD (Bolt-On Bushing)	Meritor 16-1/2" Q Plus	
17-3/8"	1	1-1/2"-10	1-1/2"	E-2795 E-2794	LH RH	T	See Camshaft pages	Multi-App 16-1/2"	Single Groove Journal
17-3/8"	5	1-1/2"-10	1-1/2"	E-9751 E-9752	LH RH	T	E-2469 (Nylon Bushing)	Spicer 12-1/4"	0794L/R Head Fast-Rise
17-3/8"	2	1-1/2"-10	1-1/2"	E-5516 E-5517	LH RH	T	E-2287	Spicer 16-1/2" XL	Double Groove Journal - 1-5/8", 2-7/32"
17-3/8"	1	1-1/2"-28	1-1/2"	E-9725 E-9726	LH RH	T	E-2287	Spicer 16-1/2"	Double Groove Journal - 1-5/8", 2-7/32"
17-7/16"	2	1-1/2"-28	1-1/2"	E-5522 E-5523	LH RH	T	E-2287	Spicer 16-1/2" XL	Double Groove Journal - 1-5/8", 2-7/32"
17-7/16"	2	1-1/2"-28	1-5/8"	E-9731 E-9732	LH RH	T	E-11910, E-9790A	Spicer 16-1/2" XL	Single Groove Journal - 2-7/32"

*Left or Right Hand description refers to the rotation of the Camshaft Head. This description does not always match the position of the Camshaft on the axle.
AXLE = S-Steering; D-Drive; T-Trailer

EUCLID CAMSHAFT E.S.P. GUIDE

Listed by Camshaft Length from under head to beginning of lock ring groove.

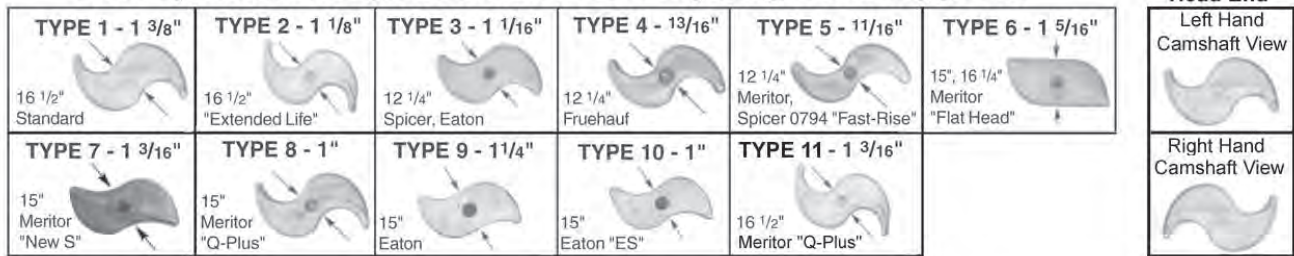

Camshaft Head photos are for identification purposes only — Actual camshaft head may vary slightly in dimension or appearance.

LENGTH	HEAD TYPE	SPLINE	JRNL. DIA.	EUCLID NO.	HEAD END*	AXLE	CAMSHAFT KIT	MFR./BRAKE SIZE	NOTES
17-29/64"	11	1-1/2"-28	1-1/2"	E-11599 E-11598	LH RH	D	E-3993B	Meritor 16-1/2" Q Plus	
17-23/32"	11	1-1/2"-10	1-1/2"	E-4715A E-4714A	LH RH	D	E-3993B	Meritor 16-1/2" Q Plus	See E-4714 & E-4715 for Trailer Cams
17-3/4"	1	1-1/2"-10	1-1/2"	E-4715 E-4714	LH RH	T	See Camshaft pages	Multi-App 16-1/2" Q	Single Groove Journal
17-61/64"	11	1-1/2"-28	1-1/2"	E-11601 E-11600	LH RH	D	E-3993B	Meritor 16-1/2" Q Plus	
18"	5	1-1/2"-10	1-1/2"	E-9749 E-9750	LH RH	T	E-2469 (Nylon Bushing)	Spicer 12-1/4"	0794L/R Head Fast-Rise
18-3/8"	11	1-1/2"-10	1-1/2"	E-689A E-688A	LH RH	D	E-3993B	Meritor 16-1/2" Q Plus	
18-3/8"	1	1-1/2"-10	1-1/2"	E-689 E-688	LH RH	T	See Camshaft pages	Multi-App 16-1/2" Q	Single Groove Journal
18-29/64"	11	1-1/2"-28	1-1/2"	E-11603 E-11602	LH RH	D	E-3993B	Meritor 16-1/2" Q Plus	
18-29/64"	11	1-1/2"-28	1-5/8"	E-11643 E-11642	LH RH	D	E-11904	Meritor 16-1/2" Q Plus	
18-19/32"	11	1-1/2"-28	1-1/2"	E-11605 E-11604	LH RH	D	E-3993B	Meritor 16-1/2" Q Plus	
18-5/8"	11	1-1/2"-10	1-1/2"	E-2413A E-2412A	LH RH	D	E-3993B	Meritor 16-1/2" Q Plus	
18-5/8"	1	1-1/2"-10	1-1/2"	E-2413 E-2412	LH RH	T	See Camshaft pages	Multi-App 16-1/2" Q	Single Groove Journal
18-7/8"	5	1-1/2"-10	1-1/2"	E-9265 E-9266	LH RH	T	E-2469 (Nylon Bushing)	Spicer 12-1/4"	0794L/R Head Fast-Rise
18-7/8"	3	1-1/2"-10	1-1/2"	E-9743 E-9744	LH RH	T	E-2469 (Nylon Bushing)	Spicer 12-1/4"	Standard Head
19-1/2"	2	1-1/2"-10	1-1/2"	E-9739 E-9740	LH RH	T	E-2287	Spicer 16-1/2" XL	Double Groove Journal - 1-5/8", 2-7/32"
19-1/2"	1	1-1/2"-10	1-5/8"	E-2693 E-2694	LH RH	T	E-2696A	Eaton 16-1/2"	Trailer Axle
19-1/2"	2	1-1/2"-10	1-5/8"	E-5494 E-5495	LH RH	T	E-2696A	Eaton 16-1/2" ES	
19-1/2"	2	1-1/2"-28	1-5/8"	E-9057 E-9058	LH RH	T	E-2696A	Eaton 16-1/2" ES	
20-7/32"	1	1-1/2"-28	1-5/8"	E-4723 E-4722	LH RH	T	E-2696A	Eaton 16-1/2"	
20-5/16"	3	1-1/2"-10	1-1/2"	E-1394 E-1393	LH RH	T	E-2494	Eaton 12-1/4"	
20-5/16"	4	1-1/2"-28	1-1/2"	E-10919 E-10920	LH RH	T	E-2469	Dexter 12-1/4"	Single Groove Journal
20-3/8"	1	1-1/2"-10	1-1/2"	E-2107 E-2108	LH RH	T	See Camshaft pages	Multi-App 16-1/2"	Double Groove Journal
20-3/8"	1	1-1/2"-10	1-1/2"	E-557 E-556	LH RH	T	See Camshaft pages	Multi-App 16-1/2"	Double Groove Journal, Full Length Heat Treat
20-3/8"	2	1-1/2"-10	1-1/2"	E-5518 E-5519	LH RH	T	E-2287	Spicer 16-1/2" XL	Double Groove Journal - 1-5/8", 2-7/32"

*Left or Right Hand description refers to the rotation of the Camshaft Head. This description does not always match the position of the Camshaft on the axle.

AXLE = S-Steering; D-Drive; T-Trailer

EUCLID CAMSHAFT E.S.P. GUIDE

Listed by Camshaft Length from under head to beginning of lock ring groove.

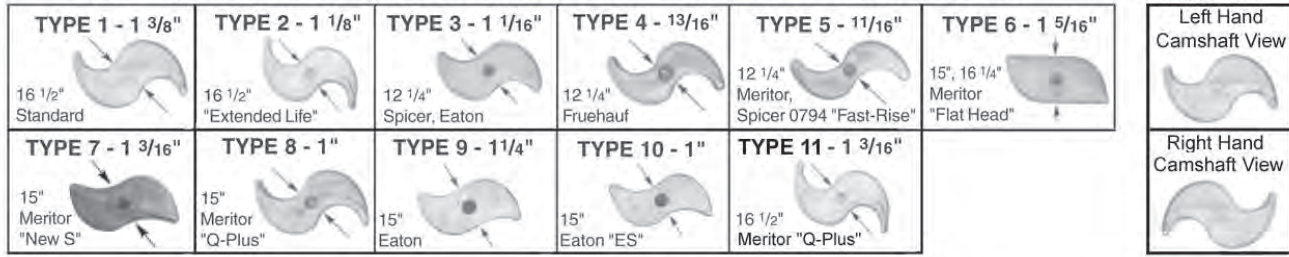

Camshaft Head photos are for identification purposes only — Actual camshaft head may vary slightly in dimension or appearance.

LENGTH	HEAD TYPE	SPLINE	JRNL. DIA.	EUCLID NO.	HEAD END*	AXLE	CAMSHAFT KIT	MFR./BRAKE SIZE	NOTES
20-3/8"	5	1-1/2"-10	1-5/8"	E-4900 E-4901	LH RH	T	E-3520AHD, E-3989AHD	Meritor 12-1/4" P and Q	
20-3/8"	1	1-1/2"-28	1-1/2"	E-3854 E-3855	LH RH	T	E-2287	Spicer 16-1/2"	Double Groove Journal - 1-5/8", 2-7/32"
20-3/8"	5	1-1/2"-28	1-5/8"	E-3516 E-3517	LH RH	T	E-3520AHD, E-3989AHD	Meritor 12-1/4" P and Q	
20-13/32"	11	1-1/2"-10	1-5/8"	E-2449A E-2450A	LH RH	T	See Camshaft pages	Meritor 16-1/2" Q Plus	
20-13/32"	11	1-1/2"-28	1-5/8"	E-2443B E-2444B	LH RH	T	See Camshaft pages	Meritor 16-1/2" P, Q, Q Plus	
20-13/32"	11	1-1/2"-28	1-5/8"	E-5508 E-5509	LH RH	T	E-9078HD (Press-In Bushing), E-9079HD (Bolt-On Bushing)	Meritor 16-1/2" Q Plus	
20-7/16"	11	1-1/2"-10	1-1/2"	E-1425A E-1424A	LH RH	T	See Camshaft pages	Meritor 16-1/2" Q Plus	
20-7/16"	5	1-1/2"-28	1-1/2"	E-9753 E-9754	LH RH	T	E-2469 (Nylon Bushing)	Spicer 12-1/4"	0794L/R Head Fast-Rise
20-7/16"	2	1-1/2"-28	1-1/2"	E-5524 E-5525	LH RH	T	E-2287	Spicer 16-1/2" XL	Double Groove Journal - 1-5/8", 2-7/32"
20-7/16"	2	1-1/2"-28	1-5/8"	E-9733 E-9734	LH RH	T	E-11910, E-9790A	Spicer 16-1/2" XL	Single Groove Journal
20-1/2"	5	1-1/2"-10	1-1/2"	E-9267 E-9268	LH RH	T	E-2469 (Nylon Bushing)	Spicer 12-1/4"	0794L/R Head Fast-Rise
20-1/2"	3	1-1/2"-10	1-1/2"	E-5096 E-5097	LH RH	T	E-2469 (Nylon Bushing)	Spicer 12-1/4"	Standard Head
20-9/16"	5	1-1/2"-28	1-5/8"	E-10901 E-10902	LH RH	T	E-9790A	Spicer 12-1/4"	0794L/R Head Fast-Rise
20-61/64"	11	1-1/2"-28	1-5/8"	E-11645 E-11644	LH RH	D	E-11904	Meritor 16-1/2" Q Plus	
21-3/32"	1	1-1/2"-10	1-1/2"	E-685 E-684	LH RH	T	See Camshaft pages	Multi-App 16-1/2"	Single Groove Journal
21-1/8"	3	1-1/2"-10	1-1/2"	E-1411 E-1410	LH RH	T	E-2469 (Nylon Bushing)	Spicer 12-1/4"	Standard Head
21-1/8"	4	1-1/2"-28	1-1/2"	E-10921 E-10922	LH RH	T	E-2469	Dexter 12-1/4"	Single Groove Journal
21-1/8"	1	1-5/8"-37	1-5/8"	E-2099 E-2100	LH RH	T	E-2090 (Late Model),	Fruehauf 16-1/2"	
21-3/16"	4	1-5/8"-37	1-5/8"	E-4890 E-4891	LH RH	T	E-2122 (Early Model), E-2090 (Late Model)	Fruehauf 12-1/4"	E-2122 Kit (Early Model)
21-1/4"	5	1-1/2"-10	1-1/2"	E-9269 E-9270	LH RH	T	E-2469 (Nylon Bushing)	Spicer 12-1/4"	0794L/R Head Fast-Rise
21-5/16"	5	1-1/2"-28	1-1/2"	E-9755 E-9756	LH RH	T	E-2469 (Nylon Bushing)	Spicer 12-1/4"	0794L/R Head Fast-Rise
21-5/16"	5	1-1/2"-28	1-5/8"	E-10903 E-10904	LH RH	T	E-9790A	Spicer 12-1/4"	0794L/R Head Fast-Rise
22"	5	1-1/2"-10	1-1/2"	E-9271 E-9272	LH RH	T	E-2469 (Nylon Bushing)	Spicer 12-1/4"	0794L/R Head Fast-Rise
22"	3	1-1/2"-10	1-1/2"	E-9745 E-9746	LH RH	T	E-2469 (Nylon Bushing)	Spicer 12-1/4"	Standard Head

*Left or Right Hand description refers to the rotation of the Camshaft Head. This description does not always match the position of the Camshaft on the axle.

AXLE = S-Steering; D-Drive; T-Trailer

EUCLID CAMSHAFT E.S.P. GUIDE

Listed by Camshaft Length from under head to beginning of lock ring groove.

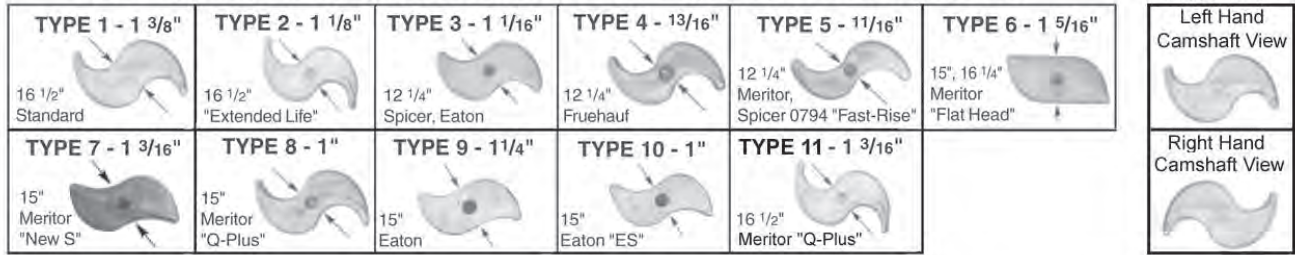

Camshaft Head photos are for identification purposes only — Actual camshaft head may vary slightly in dimension or appearance.

LENGTH	HEAD TYPE	SPLINE	JRNL. DIA.	EUCLID NO.	HEAD END*	AXLE	CAMSHAFT KIT	MFR./BRAKE SIZE	NOTES
22-1/16"	1	1-1/2"-10	1-1/2"	E-691 E-690	LH RH	T	See Camshaft pages	Multi-App 16-1/2"	Double Groove Journal
22-1/16"	5	1-1/2"-28	1-1/2"	E-9757 E-9758	LH RH	T	E-2469 (Nylon Bushing)	Spicer 12-1/4"	0794L/R Head Fast-Rise
22-5/16"	3	1-1/2"-10	1-1/2"	E-2493 E-2492	LH RH	T	E-2494	Eaton 12-1/4"	
22-5/16"	4	1-1/2"-28	1-1/2"	E-10923 E-10924	LH RH	T	E-2469	Dexter 12-1/4"	Single Groove Journal
22-3/8"	1	1-1/2"-10	1-1/2"	E-9089 E-9090	LH RH	T	See Camshaft pages	Multi-App 16-1/2"	Single Groove Journal
22-5/8"	2	1-1/2"-28	1-5/8"	E-11856 E-11857	LH RH	T	E-11910, E-9790A	Spicer 16-1/2" XL	
22-7/8"	1	1-1/2"-10	1-1/2"	E-4884 E-4885	LH RH	T	See Camshaft pages	Multi-App 16-1/2"	Single Groove Journal
22-7/8"	2	1-1/2"-10	1-1/2"	E-6101 E-6102	LH RH	T	E-2287	Spicer 16-1/2" XL	Double Groove Journal - 1-5/8", 2-7/32"
22-7/8"	1	1-1/2"-28	1-1/2"	E-6884 E-6885	LH RH	T	E-2287	Spicer 16-1/2"	Double Groove Journal - 1-5/8", 2-7/32"
22-7/8"	2	1-1/2"-28	1-5/8"	E-11858 E-11859	LH RH	T	E-11910, E-9790A	Spicer 16-1/2" XL	
22-15/16"	2	1-1/2"-28	1-1/2"	E-9098 E-9099	LH RH	T	E-2287	Spicer 16-1/2" XL	Double Groove Journal - 1-5/8", 2-7/32"
23-1/8"	5	1-1/2"-10	1-1/2"	E-9273 E-9274	LH RH	T	E-2469 (Nylon Bushing)	Spicer 12-1/4"	0794L/R Head Fast-Rise
23-3/16"	5	1-1/2"-28	1-1/2"	E-9759 E-9760	LH RH	T	E-2469 (Nylon Bushing)	Spicer 12-1/4"	0794L/R Head Fast-Rise
23-3/16"	5	1-1/2"-28	1-5/8"	E-10905 E-10906	LH RH	T	E-9790A	Spicer 12-1/4"	0794L/R Head Fast-Rise
23-7/32"	5	1-1/2"-28	1-5/8"	E-9087 E-9088	LH RH	T	E-3520AHD, E-3989AHD	Meritor 12-1/4" P and Q	
23-1/4"	3	1-1/2"-10	1-1/2"	E-1423 E-1422	LH RH	T	E-2469 (Nylon Bushing)	Spicer 12-1/4"	Standard Head
23-3/8"	4	1-1/2"-28	1-1/2"	E-10925 E-10926	LH RH	T	E-2469	Dexter 12-1/4"	Single Groove Journal
23-3/8"	8	1-1/2"-28	1-5/8"	E-11958 E-11959	LH RH	T		Meritor 15" Q Plus	
23-7/16"	1	1-1/2"-10	1-1/2"	E-1095 E-1094	LH RH	T	See Camshaft pages	Multi-App 16-1/2"	Double Groove Journal
23-7/16"	1	1-1/2"-28	1-1/2"	E-3856 E-3857	LH RH	T	E-2287	Spicer 16-1/2"	Double Groove Journal - 1-5/8", 2-7/32"
23-1/2"	5	1-1/2"-10	1-1/2"	E-9275 E-9276	LH RH	T	E-2469 (Nylon Bushing)	Spicer 12-1/4"	0794L/R Head Fast-Rise
23-1/2"	2	1-1/2"-10	1-1/2"	E-5520 E-5521	LH RH	T	E-2287	Spicer 16-1/2" XL	Double Groove Journal - 1-5/8", 2-7/32"
23-9/16"	2	1-1/2"-28	1-1/2"	E-5526 E-5527	LH RH	T	E-2287	Spicer 16-1/2" XL	Double Groove Journal - 1-5/8", 2-7/32"
23-9/16"	2	1-1/2"-28	1-5/8"	E-9735 E-9736	LH RH	T	E-11910, E-9790A	Spicer 16-1/2" XL	Single Groove Journal - 2-7/32"
23-3/4"	1	1-1/2"-10	1-5/8"	E-4721 E-4720	LH RH	T	E-2696A	Eaton 16-1/2"	Trailer Axle

*Left or Right Hand description refers to the rotation of the Camshaft Head. This description does not always match the position of the Camshaft on the axle.

AXLE = S-Steering; D-Drive; T-Trailer

U.S. 888-725-9355

Canada 800-387-3889

XpresswayPlus.com

1-181

EUCLID CAMSHAFT E.S.P. GUIDE

Listed by Camshaft Length from under head to beginning of lock ring groove.

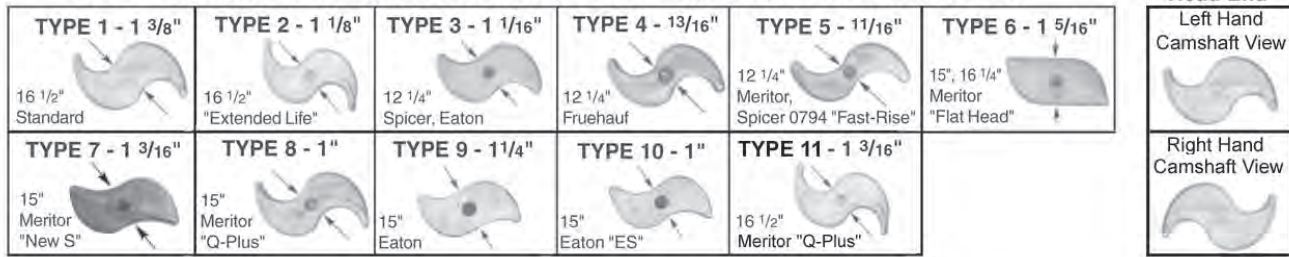

Camshaft Head photos are for identification purposes only — Actual camshaft head may vary slightly in dimension or appearance.

LENGTH	HEAD TYPE	SPLINE	JRN. DIA.	EUCLID NO.	HEAD END*	AXLE	CAMSHAFT KIT	MFR./BRAKE SIZE	NOTES
23-3/4"	2	1-1/2"-10	1-5/8"	E-5496	LH	T	E-2696A	Eaton 16-1/2" ES	Trailer Axle
				E-5497	RH				
23-3/4"	2	1-1/2"-28	1-5/8"	E-9059	LH	T	E-2696A	Eaton 16-1/2" ES	Trailer Axle
				E-9060	RH				
23-7/8"	5	1-1/2"-10	1-1/2"	E-9277	LH	T	E-2469 (Nylon Bushing)	Spicer 12-1/4"	0794L/R Head Fast-Rise
				E-9278	RH				
23-7/8"	3	1-1/2"-10	1-1/2"	E-1421	LH	T	E-2469 (Nylon Bushing)	Spicer 12-1/4"	Standard Head
				E-1420	RH				
23-7/8"	1	1-5/8"-37	1-5/8"	E-3861	LH	T	E-2090 (Late Model)	Fruehauf 16-1/2"	E-2122 Kit (Early Model)
				E-3862	RH				
23-15/16"	5	1-1/2"-28	1-5/8"	E-10907	LH	T	E-9790A	Spicer 12-1/4"	0794L/R Head Fast-Rise
				E-10908	RH				
24"	1	1-1/2"-10	1-1/2"	E-4717	LH	T	See Camshaft pages	Multi-App 16-1/2"	Single Groove Journal
				E-4716	RH				
24"	2	1-1/2"-10	1-1/2"	E-9727	LH	T	E-2287	Spicer 16-1/2" XL	Double Groove Journal - 1-5/8", 2-7/32"
				E-9728	RH				
24-1/16"	11	1-1/2"-10	1-5/8"	E-2451A	LH	T	See Camshaft pages	Meritor 16-1/2" Q Plus	
				E-2452A	RH				
24-1/16"	2	1-1/2"-28	1-1/2"	E-9100	LH	T	E-2287	Spicer 16-1/2" XL	Double Groove Journal - 1-5/8", 2-7/32"
				E-9101	RH				
24-1/16"	11	1-1/2"-28	1-5/8"	E-5510	LH	T	E-9078HD (Press-In Bushing), E-9079HD (Bolt-On Bushing)	Meritor 16-1/2" Q Plus	
				E-5511	RH				
24-1/16"	11	1-1/2"-28	1-5/8"	E-2445B	LH	T	See Camshaft pages	Meritor 16-1/2" P, Q, Q Plus	
				E-2446B	RH				
24-1/8"	2	1-1/2"-28	1-5/8"	E-10909	LH	T	E-11910, E-9790A	Spicer 16-1/2" XL	Single Groove Journal 2-7/32"
				E-10910	RH				
24-3/8"	1	1-1/2"-10	1-1/2"	E-2797	LH	T	See Camshaft pages	Multi-App 16-1/2"	Single Groove Journal
				E-2796	RH				
24-3/8"	2	1-1/2"-10	1-1/2"	E-6103	LH	T	E-2287	Spicer 16-1/2" XL	Double Groove Journal - 1-5/8", 2-7/32"
				E-6104	RH				
24-5/8"	3	1-1/2"-10	1-1/2"	E-2793	LH	T	E-2469 (Nylon Bushing)	Spicer 12-1/4"	Standard Head
				E-2792	RH				
24-5/8"	4	1-1/2"-28	1-1/2"	E-10927	LH	T	E-2469	Dexter 12-1/4"	Single Groove Journal
				E-10928	RH				
25-3/4"	1	1-1/2"-10	1-1/2"	E-4719	LH	T	See Camshaft pages	Multi-App 16-1/2"	Single Groove Journal
				E-4718	RH				
26-1/4"	5	1-1/2"-10	1-1/2"	E-9279	LH	T	E-2469 (Nylon Bushing)	Spicer 12-1/4"	0794L/R Head Fast-Rise
				E-9280	RH				
26-1/4"	1	1-1/2"-10	1-1/2"	E-7217	LH	T	E-2287	Spicer 16-1/2"	Single Groove Journal - 2-7/32"
				E-7218	RH				
26-1/4"	2	1-1/2"-10	1-1/2"	E-9741	LH	T	E-2287	Spicer 16-1/2" XL	Double Groove Journal - 1-5/8", 2-7/32"
				E-9742	RH				
26-1/4"	2	1-1/2"-28	1-5/8"	E-11860	LH	T	E-11910, E-9790A	Spicer 16-1/2" XL	
				E-11861	RH				
26-1/2"	3	1-1/2"-10	1-1/2"	E-9747	LH	T	E-2469 (Nylon Bushing)	Spicer 12-1/4"	Standard Head
				E-9748	RH				
26-1/2"	1	1-1/2"-10	1-1/2"	E-7219	LH	T	E-2287	Spicer 16-1/2"	Single Groove Journal - 2-7/32"
				E-7220	RH				

*Left or Right Hand description refers to the rotation of the Camshaft Head. This description does not always match the position of the Camshaft on the axle.
 AXLE = S-Steering; D-Drive; T-Trailer

EUCLID CAMSHAFT E.S.P. GUIDE

Listed by Camshaft Length from under head to beginning of lock ring groove.

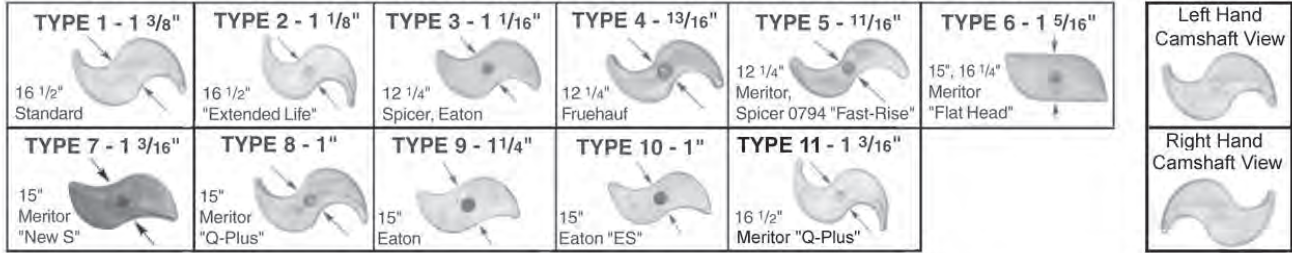

Camshaft Head photos are for identification purposes only — Actual camshaft head may vary slightly in dimension or appearance.

LENGTH	HEAD TYPE	SPLINE	JRNL. DIA.	EUCLID NO.	HEAD END*	AXLE	CAMSHAFT KIT	MFR./BRAKE SIZE	NOTES
26-1/2"	4	1-1/2"-28	1-1/2"	E-10929	LH	T	E-2469	Dexter 12-1/4"	Single Groove Journal
				E-10930	RH				
26-15/16"	2	1-1/2"-28	1-1/2"	E-9729	LH	T	E-2287	Spicer 16-1/2" XL	Double Groove Journal - 1-5/8", 2-7/32"
				E-9730	RH				
26-15/16"	2	1-1/2"-28	1-5/8"	E-9737	LH	T	E-11910, E-9790A	Spicer 16-1/2" XL	Single Groove Journal - 2-7/32"
				E-9738	RH				
30-1/4"	2	1-1/2"-28	1-5/8"	E-11862	LH	T	E-11910, E-9790A	Spicer 16-1/2" XL	
				E-11863	RH				

*Left or Right Hand description refers to the rotation of the Camshaft Head. This description does not always match the position of the Camshaft on the axle.
 AXLE = S-Steering; D-Drive; T-Trailer

BRAKE CAMSHAFTS — STEERING AXLE

FOR EATON STEERING AXLES WITH 15" SINGLE ANCHOR PIN BRAKES

Use Camshaft Repair Kit:
E-5140
Use Brake Shoe Kit:
E-5139

1 1/4" Dia. - 10 Spline

All Euclid Cam Lengths are measured from **under Cam Head to beginning of Lock Ring Groove.**



APPLICATION & GENERAL INFORMATION

EUCLID NO.	HEAD END	REPLACES	A
E-5058	LH Eaton 1006724		7-5/8"
E-5059	RH Eaton 1006725		
E-5060	LH Eaton 1006730		8-9/16"
E-5061	RH Eaton 1006731		
E-5066	LH Eaton 1008006		8-15/16"
E-5067	RH Eaton 1008007		
E-5131	LH Eaton 1006866		9-3/16"
E-5132	RH Eaton 1006867		
E-5133	LH Eaton 1006728		9-9/16"
E-5134	RH Eaton 1006729		
E-5135	LH Eaton 1006940		9-25/32"
E-5136	RH Eaton 1006941		
E-5062	LH Eaton 1006864		10-29/32"
E-5063	RH Eaton 1006865		

FOR EATON STEERING AXLES WITH 15" "ES" "EXTENDED SERVICE" BRAKES

Use Camshaft Repair Kit:
E-5140
Use Brake Shoe Kit:
E-5139

1 1/4" Dia. - 10 Spline

All Euclid Cam Lengths are measured from **under Cam Head to beginning of Lock Ring Groove.**



Important Note: These cams are "extended life" versions of this manufacturer's "standard version". If retrofitting from "standard" to "extended life" camshafts, Euclid strongly recommends replacing both cams on a single axle or all cams on tandem axles to promote a balanced brake condition.

APPLICATION & GENERAL INFORMATION

EUCLID NO.	HEAD END	REPLACES	A
E-9028	LH Eaton 813486		7-15/16"
E-9029	RH Eaton 813487		
E-9030	LH Eaton 813480		9-3/16"
E-9031	RH Eaton 813481		
E-9032	LH Eaton 813482		9-9/16"
E-9033	RH Eaton 813483		
E-9034	LH Eaton 813494		9-25/32"
E-9035	RH Eaton 813495		

BRAKE CAMSHAFTS — STEERING AXLE

FOR MERITOR STEERING AXLES WITH 15" "T" BRAKES

Use Camshaft Repair Kit:
E-3446
 Use Brake Shoe Kit:
E-4691

1 1/4" Dia. - 10 Spline

All Euclid Cam Lengths are measured from under Cam Head to beginning of Lock Ring Groove.

Nominal Head Dimension - 1 5/16"

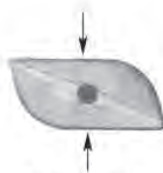

Left Hand



EUCLID NO.	HEAD END	REPLACES	A	APPLICATION & GENERAL INFORMATION
E-4912	LH	Meritor 2210Q5399	7-21/32"	
E-4913	RH	Meritor 2210R5400		
E-3460	LH	Meritor 2210F6844	7-15/16"	
E-3461	RH	Meritor 2210G6845		
E-4916	LH	Meritor 2210U5611S	8-15/32"	
E-4917	RH	Meritor 2210Y5953		
E-4918	LH	Meritor 2210C5619	9-1/4"	
E-4919	RH	Meritor 2210D5620		
E-4936	LH	Meritor 2210V6860	9-9/16"	
E-4937	RH	Meritor 2210W6861		

FOR MERITOR STEERING AXLES WITH 15" "T" AND "Q" BRAKE - NEW STYLE "S"

Use Camshaft Repair Kit:
E-3446 ("T")
E-3876 ("Q")

1 1/4" Dia. - 10 Spline

All Euclid Cam Lengths are measured from under Cam Head to beginning of Lock Ring Groove.

Nominal Head Dimension - 1 3/16"

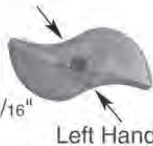

Left Hand



Use "T" Brake Repair Kit:
E-4961
 Use "Q" Brake Repair Kit:
E-3869

Note: These cams can replace old style "flat" head cams in pairs.

EUCLID NO.	HEAD END	REPLACES	A	APPLICATION & GENERAL INFORMATION
E-9693	LH	Meritor 2210D6842	7-21/32"	
E-9694	RH	Meritor 2210E6843		
E-9695	LH	Meritor 2210F6844	7-15/16"	
E-9696	RH	Meritor 2210G6845		
E-9697	LH	Meritor 2210M6851	8-1/2"	
E-9698	RH	Meritor 2210N6852		
E-9699	LH	Meritor 2210R6856	9-1/4"	
E-9700	RH	Meritor 2210S6857		
E-9701	LH	Meritor 2210V6860	9-9/16"	
E-9702	RH	Meritor 2210W6861		

BRAKE CAMSHAFTS — STEERING AXLE

FOR MERITOR STEERING AXLES WITH 15" "Q" BRAKES - 1-1/2" OFFSET BACKING PLATE

Use Camshaft Repair Kit:
E-3876
Use Brake Repair Kit:
E-3869

1 1/4" Dia. - 24 Spline

All Euclid Cam Lengths are measured from **under Cam Head** to beginning of Lock Ring Groove.

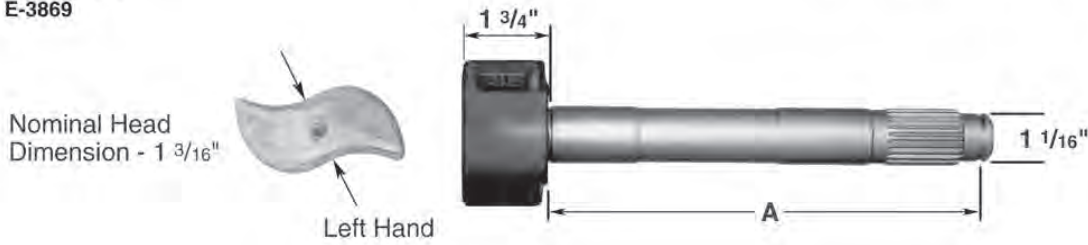

EUCLID NO.	HEAD END	REPLACES	A	APPLICATION & GENERAL INFORMATION
E-9707	LH	Meritor 2210J6614	8-1/2"	
E-9708	RH	Meritor 2210X6732		
E-5529	LH	Meritor 2210C6737	9-1/4"	
E-5530	RH	Meritor 2210D6738		
E-9711	LH	Meritor 2210L6746	9-9/16"	
E-9712	RH	Meritor 2210M6747		

FOR MERITOR STEERING AXLES WITH 15" "Q" BRAKES - 2" OFFSET BACKING PLATE

Use Camshaft Repair Kit:
E-3876
Use Brake Repair Kit:
E-3869

1 1/4" Dia. - 24 Spline

All Euclid Cam Lengths are measured from **under Cam Head** to beginning of Lock Ring Groove.

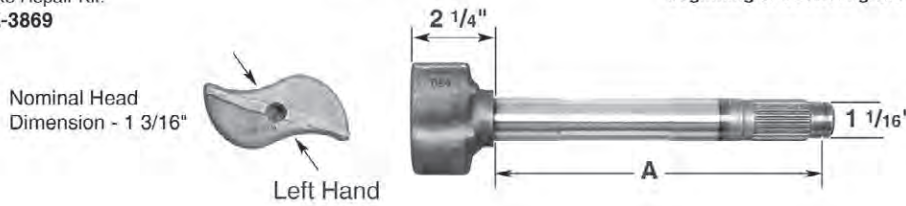

EUCLID NO.	HEAD END	REPLACES	A	APPLICATION & GENERAL INFORMATION
E-9713	LH	Meritor 2210Q6725	7-13/16"	
E-9714	RH	Meritor 2210R6726		
E-9715	LH	Meritor 2210E6739	9-13/32"	
E-9716	RH	Meritor 2210F6740		
E-9717	LH	Meritor 2210Q6751	10-1/16"	
E-9718	RH	Meritor 2210R6752		

BRAKE CAMSHAFTS — STEERING AXLE

FOR MERITOR STEERING AXLES WITH 15" "T" BRAKES

Use Camshaft Repair Kit:
E-3468A
Use Brake Repair Kit:
E-4691

1 1/2" Dia. - 10 Spline

All Euclid Cam Lengths are measured from under Cam Head to beginning of Lock Ring Groove.

Nominal Head Dimension - 1 5/16"



APPLICATION & GENERAL INFORMATION

EUCLID NO.	HEAD END	REPLACES	A
E-1090	LH Meritor	2210W5405	7-9/16"
E-1089	RH Meritor	2210X5406	
E-4991	LH Meritor	2210Y5667	8-1/2"
E-4992	RH Meritor	2210Z5668	
E-4993	LH Meritor	2210G5727	8-21/32"
E-4994	RH Meritor	2210H5728	
E-4995	LH Meritor	2210E5803	8-7/8"
E-4996	RH Meritor	2210F5804	8-7/8"

FOR MERITOR STEERING AXLES WITH 15" "Q PLUS" BRAKES

Use Camshaft Repair Kit:
E-3993B
E-11904 - LX/MX 500

1 1/2" Dia. - 28 Spline

All Euclid Cam Lengths are measured from under Cam Head to beginning of Lock Ring Groove.

Use Brake Repair Kit:
E-9064

Nominal Head Dimension - 1"

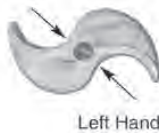

APPLICATION AND GENERAL INFORMATION

EUCLID NO.	HEAD TYPE	REPLACES	A	B
E-11520	LH Meritor	2210H7418	8-29/64"	
E-11521	RH Meritor	2210J7420		
E-11522	LH Meritor	2210R7428		
E-11523	RH Meritor	2210S7429	8-45/64"	
E-11968	LH Meritor	2210Q8181		
E-11969	RH Meritor	2210R8182		
E-9065	LH Meritor	2210H6976	9-1/4"	2"
E-9066	RH Meritor	2210J6978		
E-9067A	LH Meritor	2210R7454	9-29/64"	
E-9068A	RH Meritor	2210S7455		
E-11538	LH Meritor	2210H7496	10-33/64"	
E-11539	RH Meritor	2210J7498		
E-11548	LH Meritor	2210P7530	11-3/8"	
E-11549	RH Meritor	2210Q7531		
E-11550	LH Meritor	2210T7534	11-19/32"	
E-11551	RH Meritor	2210U7535		
E-11567	LH Meritor	2210E7597	13-5/16"	
E-11566	RH Meritor	2210D7596		

LX/MX 500 Series

BRAKE CAMSHAFTS — DRIVE AXLE

FOR EATON DRIVE AXLE

Use Camshaft Repair Kit:
E-2125 Standard
E-10897 "ES"

1 1/2" Dia. - 10 Spline

All Euclid Cam Lengths are measured from **under Cam Head to beginning of Lock Ring Groove.**

Brake Shoe Kit For Standard Series E-1887AHD
 Brake Shoe Kit For ES Series

"ES-I" E-5481A
 "ES-II" E-10244 Drive
 "ES-III" E-10760 Steer
 Replaces Eaton No.

Note: Extended service camshafts **CAN** be used in place of standard camshafts.
 Standard camshafts **CANNOT** be used in place of extended service camshafts when using Extended service shoes and or linings.
 Extended service camshafts are .060 longer than their standard counter part to allow for a special washer under the head.

Nominal Head Dimension - Standard 1 3/8"
 ES 1 1/8"



Left Hand

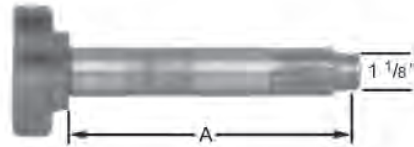

EUCLID NO.	HEAD END	REPLACES	A	APPLICATION INFORMATION
E-2800	LH	Eaton 1000087	8-9/16"	
E-2799	RH	Eaton 1000088		
E-5490	LH	Eaton 7-808708	8-5/8"	ES
E-5491	RH	Eaton 7-808709		
E-9763	LH	Eaton 40547	10-5/32"	
E-9764	RH	Eaton 40548		
E-9767	LH	Eaton 808072	10-9/16"	ES
E-9768	RH	Eaton 808073		
E-9765	LH	Eaton 45530	11-1/8"	
E-9766	RH	Eaton 45531		
E-1776	LH	Eaton 70306	11-1/2"	
E-1775	RH	Eaton 70307		
E-5492	LH	Eaton 7-806526	11-1/2"	ES
E-5493	RH	Eaton 7-806527		
E-2787	LH	Eaton 71306	12-7/16"	
E-2786	RH	Eaton 71307		
E-9769	LH	Eaton 808290	12-1/2"	ES
E-9770	RH	Eaton 808291		
E-4888	LH	Eaton 1000839	12-15/16"	
E-4889	RH	Eaton 1000840		
E-4740	LH	Eaton 35455	13-7/16"	
E-4741	RH	Eaton 35456		
E-10911	LH	Eaton 808068	13-15/32"	ES
E-10912	RH	Eaton 808069		
E-3523	LH	Eaton 1001580	14-1/4"	
E-3524	RH	Eaton 1001581		
E-9771	LH	Eaton 807862	14-5/16"	ES
E-9772	RH	Eaton 807863		
E-9055	LH	Eaton 35430	15"	
E-9056	RH	Eaton 35431		
E-10913	LH	Eaton 808064	15-1/8"	
E-10914	RH	Eaton 808065		ES
E-10915	LH	Eaton 811406	15-1/4"	
E-10916	RH	Eaton 811407		

BRAKE CAMSHAFTS — DRIVE AXLE

FOR MERITOR DRIVE AXLES WITH 16-1/2 IN. Q PLUS™ BRAKES

Use Camshaft Repair Kit:
E-3993B

1 1/2" Dia. - 10 Spline

All Euclid Cam Lengths are measured from under Cam Head to beginning of Lock Ring Groove.

Note: Extended service camshafts **CAN** be used in place of standard camshafts. Standard camshafts **CANNOT** be used in place of extended service camshafts when using Extended service shoes and or linings.

Use Brake Repair Kit:
E-2769HD
For Standard and Extended Service



"Q" Plus
Nominal Head
Dimension - 1 3/16"



EUCRID NO.	HEAD END	REPLACES	A	APPLICATION & GENERAL INFORMATION
E-4705B	LH	Meritor R607100	6-13/32"	
E-4704B	RH	Meritor R607099	7-29/32"	
E-4707B	LH	Meritor R607096	8-35/64"	
E-4706B	RH	Meritor R607095	9-1/16"	For Mack Trucks using Meritor 38,000 and 44,000 lb. axles.
E-2479B	LH	Meritor R607092	10-33/64"	
E-2478B	RH	Meritor R607091	11-1/8"	
E-9687A	LH	Meritor R607086	11-33/64"	Improved heat treating through the Cam Bushing area for longer life.
E-9688A	RH	Meritor R607085	11-11/16"	
E-2701B	LH	Meritor R607078	12-15/32"	
E-2700B	RH	Meritor R607077	13-21/32"	
E-1774C	LH	Meritor R607072	14-7/8"	
E-1773C	RH	Meritor R607071	15-5/8"	
E-1148C	LH	Meritor R607076	17-23/32"	
E-1147C	RH	Meritor R607075	18-3/8"	
E-4703B	LH	Meritor R607098	18-5/8"	
E-4702B	RH	Meritor R607097	18-3/8"	
E-4709B	LH	Meritor R607074	18-5/8"	
E-4708B	RH	Meritor R607073	18-5/8"	
E-9689A	LH	Meritor R607080	18-5/8"	
E-9690A	RH	Meritor R607079	18-5/8"	
E-9691A	LH	Meritor R607088	18-5/8"	
E-9692A	RH	Meritor R607087	18-5/8"	
E-4711B	LH	Meritor R607090	18-5/8"	
E-4710B	RH	Meritor R607089	18-5/8"	
E-4715A	LH	Meritor R607094	18-5/8"	
E-4714A	RH	Meritor R607093	18-5/8"	
E-689A	LH	Meritor R607064	18-5/8"	
E-688A	RH	Meritor R607063	18-5/8"	
E-2413A	LH	Meritor R607084	18-5/8"	
E-2412A	RH	Meritor R607083	18-5/8"	

BRAKE CAMSHAFTS — DRIVE AXLE

FOR MERITOR DRIVE AXLES WITH 16-1/2" STANDARD BRAKES

Use Camshaft Repair Kit:
E-2086B (P Brakes)
E-3993B (Q Brakes)

1 1/2" Dia. - 10 Spline

All Euclid Cam Lengths are measured from under Cam Head to beginning of Lock Ring Groove.

Note: Standard camshafts **CANNOT** be used in place of extended service camshafts when using Extended service shoes and or linings.

Use "P" Brake Repair Kit:
KIT-4HD
 Use "Q" Brake Repair Kit:
E-2769HD

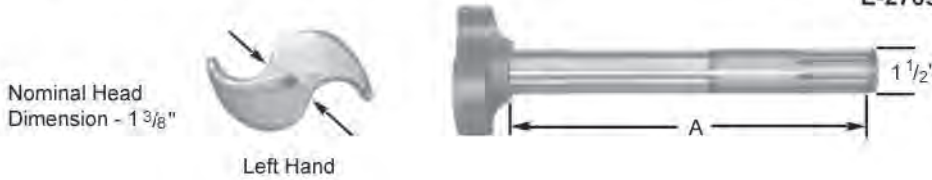

EUCLID NO.	HEAD END		REPLACES	A	APPLICATION & GENERAL INFORMATION
E-5057	LH	Meritor	2210F5544	8-1/16"	
E-5056	RH	Meritor	2210E5543		
E-2715A	LH	Meritor	2210F5726	12-1/16"	
E-2714A	RH	Meritor	2210E5725		

MERITOR TRANSIT CAMS 1-1/2 IN. DIAMETER

Use Camshaft Repair Kit:
E-2086B

1 1/2" Dia. - 10 Spline

All Euclid Cam Lengths are measured from under Cam Head to beginning of Lock Ring Groove.

Note: Standard camshafts **CANNOT** be used in place of extended service camshafts when using Extended service shoes and or linings.

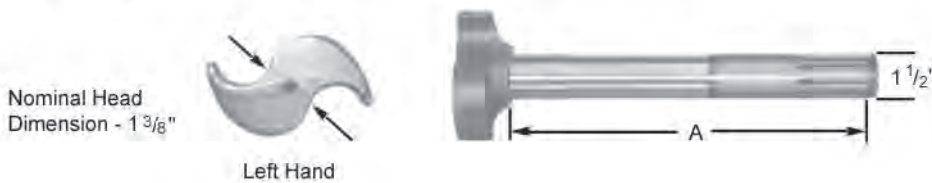

EUCLID NO.	HEAD END		REPLACES	A	APPLICATION & GENERAL INFORMATION
E-10895	LH	Meritor	2210U4909	5-13/64"	
E-10896	RH	Meritor	2210V4910		
E-10863	LH	Meritor	2210Q4905	5-3/8"	Bolt style end for slack retainer.
E-10864	RH	Meritor	2210R4906		
E-10859	LH	Meritor	2210S4907	6-1/4"	
E-10860	RH	Meritor	2210T4908		
E-10862	LH	Meritor	2210X5536	7-27/32"	
E-10861	RH	Meritor	2210W5535		

BRAKE CAMSHAFTS — DRIVE AXLE

FOR MERITOR DRIVE AXLES WITH 16-1/2" Q PLUS™ BRAKES

Use Camshaft Repair Kit:

- E-3993B E-5513 (Short Kit)
- E-9080 E-5094A (Mack App.)
- E-11904 LX/MX 500 Series (with 1-5/8" Bushing Journal)

1 1/2" Dia. - 28 Spline

All Euclid Cam Lengths are measured from under Cam Head to beginning of Lock Ring Groove.

Use Brake Repair Kit:
E-2769HD

For Standard and Extended Service

Note: Extended service camshafts **CAN** be used in place of standard camshafts.
Standard camshafts **CANNOT** be used in place of extended service camshafts when using Extended service shoes and or linings.



"Q" Plus
Nominal Head
Dimension - 1 3/16"

EUCLID NO.	HEAD END		REPLACES	A	APPLICATION & GENERAL INFORMATION
E-11513	LH	Meritor	2210L7344	6-13/64"	
E-11512	RH	Meritor	2210K7343	6-13/64"	
E-11515	LH	Meritor	2210Q7375	7-3/32"	
E-11514	RH	Meritor	2210P7374	7-3/32"	
E-9645	LH	Meritor	2210P5840	7-23/32"	
E-9646	RH	Meritor	2210K7395	7-23/32"	
E-9647	LH	Meritor	2210Y7409	8-1/16"	
E-9648	RH	Meritor	2210X7408	8-1/16"	
E-11517	LH	Meritor	2210C7413	8-13/64"	
E-11516	RH	Meritor	2210B7412	8-13/64"	
E-11519	LH	Meritor	2210G7417	8-5/16"	
E-11518	RH	Meritor	2210F7416	8-5/16"	
E-9649	LH	Meritor	2210Q7427	8-9/16"	
E-9650	RH	Meritor	2210P7426	8-9/16"	
E-11609	LH	Meritor	2210X8318	8-37/64"	LX/MX 500 (1-5/8" Bushing Journal)
E-11608	RH	Meritor	2210W8317	8-37/64"	LX/MX 500 (1-5/8" Bushing Journal)
E-11525	LH	Meritor	2210U7431	8-45/64"	
E-11524	RH	Meritor	2210T7430	8-45/64"	
E-9651	LH	Meritor	2210G7443	9-1/16"	Tractor, Transit, Truck
E-9652	RH	Meritor	2210F7442	9-1/16"	Tractor, Transit, Truck
E-11611	LH	Meritor	2210T8184	9-5/16"	LX/MX 500 (1-5/8" Bushing Journal)
E-11610	RH	Meritor	2210S8183	9-5/16"	LX/MX 500 (1-5/8" Bushing Journal)
E-11527	LH	Meritor	2210Q7453	9-5/16"	
E-11526	RH	Meritor	2210P7452	9-5/16"	
E-9653	LH	Meritor	2210U7457	9-7/16"	Tractor, Transit, Truck
E-9654	RH	Meritor	2210T7456	9-7/16"	Tractor, Transit, Truck
E-11613	LH	Meritor	2210Z8346	9-37/64"	LX/MX 500 (1-5/8" Bushing Journal)
E-11612	RH	Meritor	2210Y8345	9-37/64"	LX/MX 500 (1-5/8" Bushing Journal)
E-11529	LH	Meritor	2210C7465	9-45/64"	
E-11528	RH	Meritor	2210B7464	9-45/64"	
E-11531	LH	Meritor	2210G7469	9-13/16"	
E-11530	RH	Meritor	2210F7468	9-13/16"	
E-11533	LH	Meritor	2210L7474	9-61/64"	
E-11532	RH	Meritor	2210K7473	9-61/64"	
E-11535	LH	Meritor	2210Q7479	10-3/32"	
E-11534	RH	Meritor	2210P7478	10-3/32"	
E-5504A	LH	Meritor	2210U7483	10-3/16"	Trucks and Tractors
E-5505A	RH	Meritor	2210T7482	10-3/16"	Trucks and Tractors
E-11537	LH	Meritor	2210U7485	10-13/64"	
E-11536	RH	Meritor	2210V7484	10-13/64"	
E-9655	LH	Meritor	2210Q9659	10-13/32"	
E-9656	RH	Meritor	2210D7492	10-13/32"	
E-11541	LH	Meritor	2210L7500	10-19/32"	
E-11540	RH	Meritor	2210K7499	10-19/32"	
E-11543	LH	Meritor	2210N7502	10-19/32"	Induction hardened body.
E-11542	RH	Meritor	2210M7501	10-19/32"	Induction hardened body.

BRAKE CAMSHAFTS — DRIVE AXLE

FOR MERITOR DRIVE AXLES WITH 16-1/2" Q PLUS™ BRAKES

Use Camshaft Repair Kit:

E-3993B E-5513 (Short Kit)

E-9080 E-5094A (Mack App.)

E-11904 LX/MX 500 Series (with 1-5/8" Bushing Journal)

1 1/2" Dia. - 28 Spline

All Euclid Cam Lengths are measured from under Cam Head to beginning of Lock Ring Groove.

Use Brake Repair Kit:

E-2769HD

For Standard and Extended Service

Note: Extended service camshafts **CAN** be used in place of standard camshafts. Standard camshafts **CANNOT** be used in place of extended service camshafts when using Extended service shoes and or linings.



"Q" Plus
Nominal Head
Dimension - 1 3/16"

EUCLID NO.	HEAD END		REPLACES	A	APPLICATION & GENERAL INFORMATION
E-11545	LH	Meritor	2210Q7843	10-45/64"	
E-11544	RH	Meritor	2210P7842		
E-11547	LH	Meritor	2210W7511	10-13/16"	
E-11546	RH	Meritor	2210V7510		
E-9657	LH	Meritor	2210A7515	10-15/16"	
E-9658	RH	Meritor	2210Z7514		
E-9659	LH	Meritor	2210J7524	11-1/8"	
E-9660	RH	Meritor	2210H7522		
E-11619	LH	Meritor	2210Z8216	11-13/64"	LX/MX 500 (1-5/8" Bushing Journal)
E-11618	RH	Meritor	2210Y8215		
E-9661	LH	Meritor	2210A6943	11-9/16"	
E-9662	RH	Meritor	2210Z6942		
E-9663	LH	Meritor	2210H5416	11-11/16"	
E-9664	RH	Meritor	2210B7542		
E-11623	LH	Meritor	2210V8316	11-45/64"	LX/MX 500 (1-5/8" Bushing Journal)
E-11622	RH	Meritor	2210U8315		
E-11553	LH	Meritor	2210G7547	11-13/16"	
E-11552	RH	Meritor	2210F7546		
E-9665	LH	Meritor	2210L7552	11-15/16"	
E-9666	RH	Meritor	2210K7551		
E-11625	LH	Meritor	2210T8288	11-61/64"	LX/MX 500 (1-5/8" Bushing Journal)
E-11624	RH	Meritor	2210S8287		
E-11555	LH	Meritor	2210U7561	12-13/64"	
E-11554	RH	Meritor	2210T7560		
E-11557	LH	Meritor	2210Y7565	12-5/16"	
E-11556	RH	Meritor	2210X7564		
E-9667	LH	Meritor	2210C7569	12-7/16"	
E-9668	RH	Meritor	2210B7568		
E-11559	LH	Meritor	2210S7845	12-29/64"	Induction hardened body.
E-11558	RH	Meritor	2210R7844		
E-11563	LH	Meritor	2210Q7583	12-13/16"	
E-11562	RH	Meritor	2210P7582		
E-9669	LH	Meritor	2210U7587	12-15/16"	
E-9670	RH	Meritor	2210T7586		
E-11627	LH	Meritor	2210V8394	12-61/64"	LX/MX 500 (1-5/8" Bushing Journal)
E-11626	RH	Meritor	2210U8393		
E-11565	LH	Meritor	2210Y7591	13-3/32"	
E-11564	RH	Meritor	2210X7590		
E-11629	LH	Meritor	2210M8333	13-13/64"	LX/MX 500 (1-5/8" Bushing Journal)
E-11628	RH	Meritor	2210L8332		
E-9671	LH	Meritor	2210A6995	13-7/32"	
E-9672	RH	Meritor	2210Z6994		
E-9673A	LH	Meritor	2210L7838	13-7/16"	Heat Treated Body
E-9674A	RH	Meritor	2210K7837		
E-4733A	LH	Meritor	2210L7838	13-29/64"	Induction Hardened Body
E-4732A	RH	Meritor	2210K7837		
E-11631	LH	Meritor	2210X8266	13-29/64"	LX/MX 500 (1-5/8" Bushing Journal)
E-11630	RH	Meritor	2210W8265		

BRAKE CAMSHAFTS — DRIVE AXLE

FOR MERITOR DRIVE AXLES WITH 16-1/2" Q PLUS™ BRAKES

Use Camshaft Repair Kit:

- E-3993B E-5513 (Short Kit)
- E-9080 E-5094A (Mack App.)
- E-11904 LX/MX 500 Series (with 1-5/8" Bushing Journal)

1 1/2" Dia. - 28 Spline

All Euclid Cam Lengths are measured from under Cam Head to beginning of Lock Ring Groove.

Use Brake Repair Kit:
E-2769HD

For Standard and Extended Service

Note: Extended service camshafts **CAN** be used in place of standard camshafts.
Standard camshafts **CANNOT** be used in place of extended service camshafts when using Extended service shoes and/or linings.

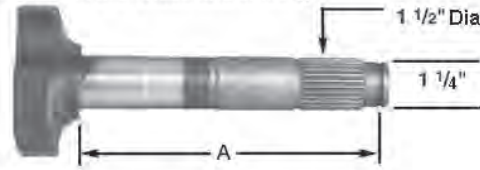

"Q" Plus
Nominal Head
Dimension - 1 3/16"

EUCLID NO.	HEAD END		REPLACES	A	APPLICATION & GENERAL INFORMATION
E-11569	LH	Meritor	2210Q7609	13-19/32"	
E-11568	RH	Meritor	2210P7608	13-19/32"	
E-4910A	LH	Meritor	2210T5454	13-45/64"	
E-4911A	RH	Meritor	2210S5453	13-45/64"	
E-11571	LH	Meritor	2210A7619	13-13/16"	
E-11570	RH	Meritor	2210Z7618	13-13/16"	
E-9675	LH	Meritor	2210Q6985	14-3/32"	
E-9676	RH	Meritor	2210P6984	14-3/32"	
E-11573	LH	Meritor	2210S7637	14-5/16"	
E-11572	RH	Meritor	2210R7636	14-5/16"	
E-11633	LH	Meritor	2210V8342	14-37/64"	LX/MX 500 (1-5/8" Bushing Journal)
E-11632	RH	Meritor	2210U8341	14-37/64"	LX/MX 500 (1-5/8" Bushing Journal)
E-9677	LH	Meritor	2210A7645	14-19/32"	
E-9678	RH	Meritor	2210M5343	14-19/32"	
E-11575	LH	Meritor	2210E7649	14-45/64"	
E-11574	RH	Meritor	2210D7648	14-45/64"	
E-9679	LH	Meritor	2210J7654	14-3/4"	
E-9680	RH	Meritor	2210H7652	14-3/4"	
E-11577	LH	Meritor	2210Q7661	14-61/64"	
E-11576	RH	Meritor	2210P7660	14-61/64"	
E-11579	LH	Meritor	2210U7665	15-3/32"	
E-11578	RH	Meritor	2210T7664	15-3/32"	
E-11581	LH	Meritor	2210W7667	15-3/32"	Induction hardened body.
E-11580	RH	Meritor	2210V7666	15-3/32"	Induction hardened body.
E-9681	LH	Meritor	2210A7671	15-3/16"	
E-9682	RH	Meritor	2210Z7670	15-3/16"	
E-11583	LH	Meritor	2210E7675	15-5/16"	
E-11582	RH	Meritor	2210D7674	15-5/16"	
E-10306A	LH	Meritor	2210N7684	15-19/32"	
E-10307A	RH	Meritor	2210M7683	15-19/32"	
E-11639	LH	Meritor	2210D8220	15-45/64"	LX/MX 500 (1-5/8" Bushing Journal)
E-11638	RH	Meritor	2210C8219	15-45/64"	LX/MX 500 (1-5/8" Bushing Journal)
E-9683	LH	Meritor	2210S7689	15-23/32"	Tractor, Transit, Truck
E-9684	RH	Meritor	2210R7688	15-23/32"	Tractor, Transit, Truck
E-11641	LH	Meritor	2210M8177	15-13/16"	LX/MX 500 (1-5/8" Bushing Journal)
E-11640	RH	Meritor	2210L8176	15-13/16"	LX/MX 500 (1-5/8" Bushing Journal)
E-11585	LH	Meritor	2210W7693	15-13/16"	
E-11584	RH	Meritor	2210V7692	15-13/16"	
E-11587	LH	Meritor	2210A7697	15-61/64"	
E-11586	RH	Meritor	2210Z7696	15-61/64"	
E-11589	LH	Meritor	2210E7701	16-3/32"	
E-11588	RH	Meritor	2210D7700	16-3/32"	
E-11591	LH	Meritor	2210S7715	16-29/64"	
E-11590	RH	Meritor	2210R7714	16-29/64"	
E-11593	LH	Meritor	2210W7719	16-19/32"	
E-11592	RH	Meritor	2210V7718	16-19/32"	
E-11595	LH	Meritor	2210E7727	16-13/16"	
E-11594	RH	Meritor	2210D7726	16-13/16"	

BRAKE CAMSHAFTS — DRIVE AXLE

FOR MERITOR DRIVE AXLES WITH 16-1/2" Q PLUS™ BRAKES

Use Camshaft Repair Kit:

E-3993B E-5513 (Short Kit)

E-9080 E-5094A (Mack App.)

E-11904 LX/MX 500 Series (with 1-5/8" Bushing Journal)

1 1/2" Dia. - 28 Spline

All Euclid Cam Lengths are measured from **under Cam Head to beginning of Lock Ring Groove.**

Use Brake Repair Kit:

E-2769HD

For Standard and Extended Service

Note: Extended service camshafts **CAN** be used in place of standard camshafts.
Standard camshafts **CANNOT** be used in place of extended service camshafts when using Extended service shoes and or linings.

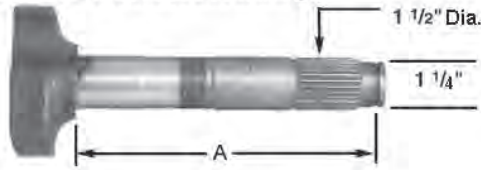

"Q" Plus
Nominal Head
Dimension - 1 3/16"

EUCLID NO.	HEAD END	REPLACES	A	APPLICATION & GENERAL INFORMATION
E-11597	LH	Meritor 2210J7732	16-61/64"	
E-11596	RH	Meritor 2210H7730		
E-11599	LH	Meritor 2210A7749	17-29/64"	
E-11598	RH	Meritor 2210Z7748		
E-11601	LH	Meritor 2210S7767	17-61/64"	
E-11600	RH	Meritor 2210R7766		
E-11603	LH	Meritor 2210J7784	18-29/64"	
E-11602	RH	Meritor 2210H7782		
E-11643	LH	Meritor 2210X8396	18-29/64"	LX/MX 500 (1-5/8" Bushing Journal)
E-11642	RH	Meritor 2210W8395		
E-11605	LH	Meritor 2210N7788	18-19/32"	
E-11604	RH	Meritor 2210M7787		
E-11645	LH	Meritor 2210F8404	20-61/64"	LX/MX 500 (1-5/8" Bushing Journal)
E-11644	RH	Meritor 2210E8403		

BRAKE CAMSHAFTS — TRAILER AXLE

DEXTER 12-1/4" TRAILER BRAKES 28 SPLINE 1-1/2" JOURNAL DIA.

Use Camshaft Repair Kit:

E-2469

1 1/2" Dia. - 28 Spline

All Euclid Cam Lengths are measured from **under Cam Head to beginning of Lock Ring Grooves.**

Use Brake Repair Kit:

E-10875

For Standard and Extended Service

Nominal Head
Dimension - 11/16"

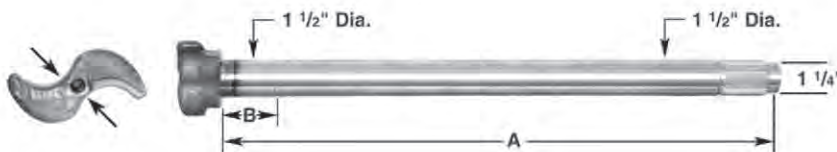

EUCLID NO.	HEAD END	REPLACES	A	B
E-10917	LH	Dexter 034-188-01	16-3/8"	
E-10918	RH	Dexter 034-189-01		
E-10919	LH	Dexter 034-188-04	20-5/16"	
E-10920	RH	Dexter 034-189-04		
E-10921	LH	Dexter 034-188-00	21-1/8"	
E-10922	RH	Dexter 034-189-00		
E-10923	LH	Dexter 034-188-03	22-5/16"	
E-10924	RH	Dexter 034-189-03		2-7/32"
E-10925	LH	Dexter 034-188-05	23-3/8"	
E-10926	RH	Dexter 034-189-05		
E-10927	LH	Dexter 034-188-11	24-5/8"	
E-10928	RH	Dexter 034-189-11		
E-10929	LH	Dexter 034-188-09	26-1/2"	
E-10930	RH	Dexter 034-189-09		

BRAKE CAMSHAFTS — TRAILER AXLE

HENDRICKSON INTRAAX® - 10 SPLINE

1 1/2" Dia. - 10 Spline

Use Camshaft Repair Kit:

- E-11450HD 2" O.D. Bushing & Seal (Exposed Cam)
- E-11897 Enclosed Cam Tube

All Euclid Cam Lengths are measured from **under Cam Head to beginning of Lock Ring Grooves.**

Use Brake Repair Kit:

E-2769HD

Nominal Head Dimension - 1-1/8"

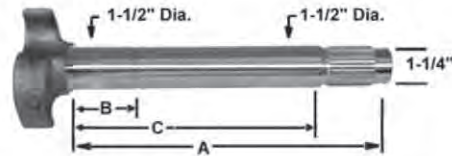

EUCLID NO.	HEAD END		REPLACES	A	B	C	APPLICATION INFORMATION
E-11864	LH	Hendrickson	S-23857-1L	11-1/32"	2-5/16"	8-11/16"	Can be used with Enclosed Cam Tube or Exposed Cam 2" O.D. bushing and seal.
E-11865	RH	Hendrickson	S-23857-1R				

HENDRICKSON INTRAAX® - 28 SPLINE

1 1/2" Dia. - 28 Spline

Use Camshaft Repair Kit:

- E-9791HD 1-7/8" O.D. Bushing & Seal (Exposed Cam)
- E-11450HD 2" O.D. Bushing & Seal (Exposed Cam)
- E-11897 Enclosed Cam Tube

All Euclid Cam Lengths are measured from **under Cam Head to beginning of Lock Ring Grooves.**

Use Brake Repair Kit:

E-2769HD

Nominal Head Dimension - 1-3/8" Std.
1-1/8" HXS

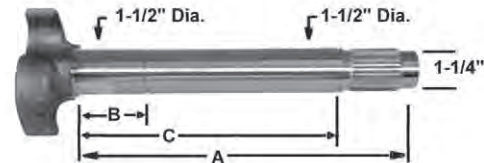

EUCLID NO.	HEAD END		REPLACES	A	B	C	APPLICATION INFORMATION
E-10899	LH	Hendrickson	S-20806-1L	11-1/32"	2-5/16"	8-11/16"	1-3/8" head. Standard Series.
E-10900	RH	Hendrickson	S-20806-1R				
E-11866	LH	Hendrickson	S-24636-1L				1-1/8" head. Can be used with Enclosed Cam Tube or Exposed Cam 2" O.D. bushing and seal.
E-11867	RH	Hendrickson	S-24636-1R				

1-1/2" DIAMETER MULTI-APPLICATION CAMSHAFTS FOR TRAILERS WITH 16-1/2" BRAKE - Double Groove

Use Camshaft Repair Kit:

- E-2089 - Eaton (Bolt-on spider)
- E-2123 - Eaton (Weld-on spider)
- E-2088AHD - Meritor
- E-2287 - Spicer
- E-2287 - Std. Forge

1 1/2" Dia. - 10 Spline

All Euclid Cam Lengths are measured from **under Cam Head to beginning of Lock Ring Groove.**

Nominal Head Dimension - 1 3/8"

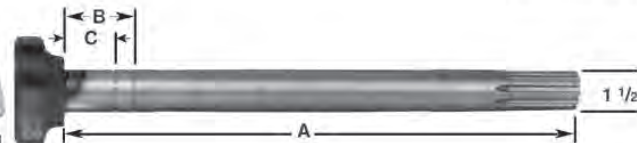
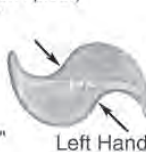

"Q" Plus Nominal Head Dimension - 1 3/16"

EUCLID NO.	HEAD END		REPLACES	A	B	C	APPLICATION & GENERAL INFORMATION
E-557	LH	Dana/Spicer	M16WK103-17	20-3/8"	2-7/32"	1-5/8"	Premium Universal. Entire camshaft is heat treated for maximum bearing life and twist resistance.
		Meritor	2210P6412				
		Std. Forge	202100-205L				
E-556	RH	Dana/Spicer	M16WK102-17				
		Meritor	2210N6410				
		Std. Forge	202100-205R				

BRAKE CAMSHAFTS — TRAILER AXLE

1-1/2" DIAMETER MULTI-APPLICATION CAMSHAFTS FOR TRAILERS WITH 16-1/2" BRAKE - Double Groove

Use Camshaft Repair Kit:

- E-2089 - Eaton (Bolt-on spider)
- E-2123 - Eaton (Weld-on spider)
- E-2088AHD - Meritor
- E-2287 - Spicer
- E-2287 - Std. Forge

1 1/2" Dia. - 10 Spline

All Euclid Cam Lengths are measured from **under Cam Head to beginning of Lock Ring Groove.**

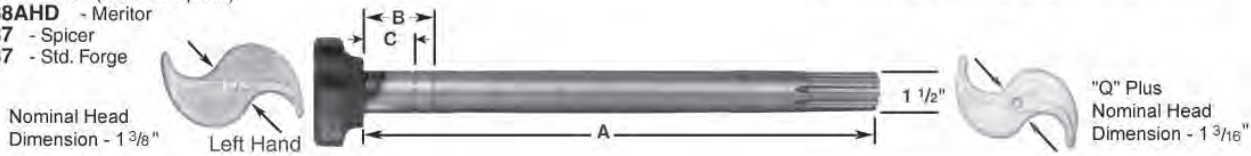

EUCLID NO.	HEAD END	REPLACES	A	B	C	APPLICATION & GENERAL
						INFORMATION
E-2107	LH	Eaton 820073 Meritor R607022	20-3/8"	2-5/16"	1-5/8"	Original Eaton Style Large S Head. Roller seats completely into S Head For Q Plus™ brakes. Standard Universal 1-5/8" Groove used on Paymaster RN and RL Axles
E-2108	RH	Eaton 820074 Meritor R607021				
E-1425A	LH	Meritor R607082				
E-1424A	RH	Meritor R607081				
E-691	LH	Dana/Spicer 17-599 Eaton B-1691-9 Meritor R607052 Std. Forge 202100-225L	22-1/16"	2-9/16"	2-7/32"	Extra long for use with Air Ride Suspensions Extra length keeps slack adjuster from rubbing on air bags and causing premature rupture
E-690	RH	Dana/Spicer 17-598 Eaton B-1691-10 Meritor R607051 Std. Forge 202100-225R				
E-1095	LH	Dana/Spicer M16WK103-25 Eaton 7-2426 Meritor R607002 Std. Forge 202100-236L	23-7/16"	2-5/16"		
E-1094	RH	Dana/Spicer M16WK102-25 Eaton 7-2425 Meritor R607001 Std. Forge 202100-236R				

BRAKE CAMSHAFTS — TRAILER AXLE

1-1/2" DIAMETER MULTI-APPLICATION CAMSHAFTS FOR TRAILERS WITH 16-1/2" BRAKES - Single Groove

Use Camshaft Repair Kit:

- E-2089** - Eaton (Bolt-on spider)
- E-2123** - Eaton (Weld-on spider)
- E-2088AHD** - Meritor
- E-2287** - Spicer
- E-2287** - Std. Forge

1 1/2" Dia. - 10 Spline

All Euclid Cam Lengths are measured from under Cam Head to beginning of Lock Ring Groove.

Nominal Head Dimension - 1 3/8"

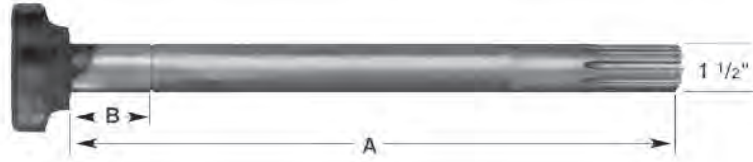
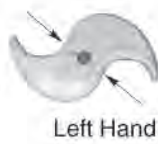

EUCLID NO.	HEAD END	REPLACES	A	B	APPLICATION & GENERAL INFORMATION
E-4892	LH	Dana/Spicer 17-611	7-13/32"		
E-4893	RH	Dana/Spicer 17-610			
E-1789	LH	Eaton 820102 Meritor R607018	10-1/8"		For Eaton Self-Contained Trailer Brakes
E-1788	RH	Eaton 820103 Meritor R607017			
E-4713	LH	Dana/Spicer M16WK102-7 Meritor R607040	16-5/16"		For use on Granning Suspensions
E-4712	RH	Dana/Spicer M16WK103-7 Meritor R607039			
E-687	LH	Dana/Spicer 17-577, M16WK103-9 Eaton 7-2402, B-1691-47, Meritor 2210Y6317 Std. Forge 202100-166L	16-1/2"		Used on Meritor R-100 Axles Also used on Ford, GMC, WhiteGMC, Diamond T Tag or Pusher Axles
E-686	RH	Dana/Spicer 17-576, M16WK102-9 Eaton 7-2401, B-1691-48 Meritor 2210X6316 Std. Forge 202100-166R		2-7/32"	
E-2795	LH	Dana/Spicer 17-569, M16WK117 Meritor R607032 Std. Forge 202100-175L	17-3/8"		
E-2794	RH	Dana/Spicer 17-568, M16WK116 Meritor R607031 Std. Forge 202100-175R			
E-4715	LH		17-3/4"		
E-4714	RH				
E-689	LH	Dana/Spicer 17-579, M16WK103-12 Eaton 72404, B1691-5 Std. Forge 202100-185L	18-3/8"		
E-688	RH	Dana/Spicer 17-578, M16WK102-12, Eaton 72403, B1691-6 Std. Forge 202100-185R	18-3/8"		

BRAKE CAMSHAFTS — TRAILER AXLE

1-1/2" DIAMETER MULTI-APPLICATION CAMSHAFTS FOR TRAILERS WITH 16-1/2" BRAKES - Single Groove

Use Camshaft Repair Kit:

- E-2089 - Eaton (Bolt-on spider)
- E-2123 - Eaton (Weld-on spider)
- E-2088AHD - Meritor
- E-2287 - Spicer
- E-2287 - Std. Forge

1 1/2" Dia. - 10 Spline

All Euclid Cam Lengths are measured from under Cam Head to beginning of Lock Ring Groove.

Nominal Head Dimension - 1 3/8"

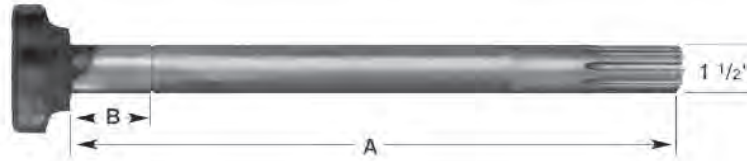
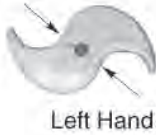

EUCLID NO.	HEAD END	REPLACES	A	B	APPLICATION & GENERAL INFORMATION	
E-2413	LH	Dana/Spicer 17579, M16WK111-4, Eaton 72406, B1691-45, Std. Forge 202100-187L	18-5/8"		1/4" longer than E-688 and E-689. Can be used for both applications	
E-2412	RH	Dana/Spicer 17578, M16WK110-4, Eaton 72405, B1691-46, Std. Forge 202100-187R				
E-685	LH	Dana/Spicer M16WK103-19, Eaton 7-2418, Meritor 2210A6319, Std. Forge 202100-213L	21-3/32"	2-7/32"		
E-684	RH	Dana/Spicer M16WK102-19, Eaton 7-2417, Meritor 2210Z6318, Std. Forge 202100-213R				
E-9089	LH	Dana/Spicer 17-585, Meritor 2210J2948, Std. Forge 202100-225L	22-3/8"			
E-9090	RH	Dana/Spicer 17-584, Meritor 2210H2946, Std. Forge 202100-225R				
E-4884	LH	Dana/Spicer 17-595, Dana/Spicer M16WK102-23, Meritor R607056	22-7/8"			
E-4885	RH	Dana/Spicer 17-594, Dana/Spicer M16WK103-23, Meritor R607055				
E-4717	LH	Dana/Spicer 17-587, M16WK102-26, Eaton 7-2426, 820084, Meritor 2210D6400, Std. Forge 202100-242L	24"			
E-4716	RH	Dana/Spicer 17-586, M16WK103-26, Eaton 7-2425, 820083, Meritor 2210C6399, Std. Forge 202100-242R				
E-2797	LH	Dana/Spicer M16WK102-83, M16WK111-12, Eaton 7-2432, Meritor R607034, Std. Forge 202100-245L	24-3/8"			For Std. Forge Axles on End Dump Trailers
E-2796	RH	Dana/Spicer M16WK103-83, M16WK110-12, Eaton 7-2431, Meritor R607033, Std. Forge 202100-245R				
E-4719	LH	Dana/Spicer M16WK102-88, Eaton 820087, Meritor R607044	25-3/4"		Extra long for use on Air Ride Suspensions	
E-4718	RH	Dana/Spicer M16WK103-88, Eaton 820088, Meritor R607043				

BRAKE CAMSHAFTS — TRAILER AXLE

FOR EATON TRAILER AXLES WITH 12-1/4" DIA. BRAKES - Double Groove

Use Camshaft Repair Kit:

E-2494

Use Brake Repair Kit:

E-2126

Nominal Head
Dimension - 1 1/16"



1 1/2" Dia. - 10 Spline

All Euclid Cam Lengths are measured from under
Cam Head to beginning of Lock Ring Groove.

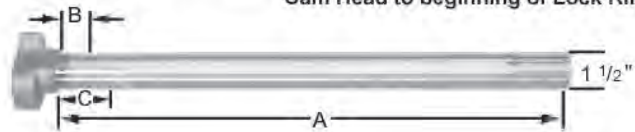

EUCLID NO.	HEAD END	REPLACES	A	B	C	APPLICATION & GENERAL INFORMATION
E-1394	LH	Eaton 820250	20-5/16"	1-11/32"	2-7/32"	For use with late model Spider E-2487 & early model Spider E-1399. Use with Air Ride Suspension
E-1393	RH	Eaton 820249				
E-2493	LH	Eaton 820243				
E-2492	RH	Eaton 820244				

FOR EATON TRAILER AXLE WITH "501" SERIES WITH 16-1/2" BRAKES

Use Camshaft Repair Kit:

E-2696A

Use Brake Repair Kit:

E-1887AHD

Nominal Head
Dimension - 1 9/32"



1 1/2" Dia. - 10 Spline

All Euclid Cam Lengths are measured from under
Cam Head to beginning of Lock Ring Groove.

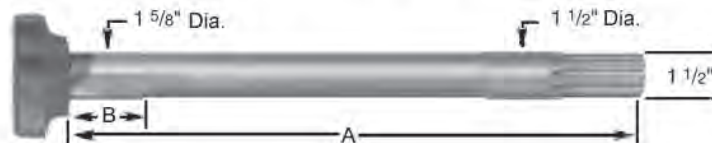

EUCLID NO.	HEAD END	REPLACES	A	B	APPLICATION & GENERAL INFORMATION
E-2693	LH	Eaton 125034	19-1/2"	2-7/32"	Used on Eaton Trailer Axles with 501 Series Brakes
E-2694	RH	Eaton 125035		2-7/32"	

FOR EATON TRAILER AXLE WITH "501" SERIES WITH 16-1/2" BRAKES

Use Camshaft Repair Kit:

E-2696A

Use Brake Repair Kit:

E-1887AHD

Nominal Head
Dimension - 1 9/32"

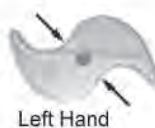

1 1/2" Dia. - 10 Spline

All Euclid Cam Lengths are measured from under
Cam Head to beginning of Lock Ring Groove.

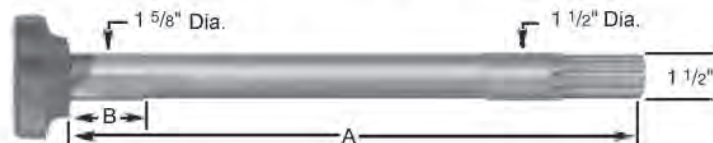

EUCLID NO.	HEAD END	REPLACES	A	B	APPLICATION & GENERAL INFORMATION
E-4721	LH	Eaton 125030	23-3/4"	2-7/32"	For use on Eaton 501 Series Brakes
E-4720	RH	Eaton 125031			

BRAKE CAMSHAFTS — TRAILER AXLE

FOR EATON TRAILER AXLE WITH "501" SERIES WITH 16-1/2" BRAKES

Use Camshaft Repair Kit:
E-2696A
Use Brake Repair Kit:
E-1887AHD

1 1/2" Dia. - 28 Spline

All Euclid Cam Lengths are measured from **under Cam Head to beginning of Lock Ring Groove.**

Nominal Head Dimension - 1 3/8"



EUCLID NO.	HEAD END	REPLACES	A	B	APPLICATION & GENERAL INFORMATION
E-4723	LH	Eaton 125042	20-7/32"	2-13/32"	
E-4722	RH	Eaton 125043		2-13/32"	

FOR EATON TRAILER AXLES WITH 16-1/2" "ES" "EXTENDED SERVICE" BRAKES

Use Brake Repair Kit:
"ES" I **E-5481A**
"ES" II **E-10244**

Use Camshaft Repair Kit:
E-2696A

1 1/2" Dia. - 10 Spline

All Euclid Cam Lengths are measured from **under Cam Head to beginning of Lock Ring Groove.**

Nominal Head Dimension - 1 1/8"

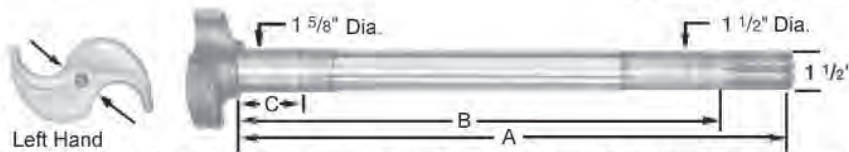

Important Note: These cams are "extended life" versions of this manufacturer's "standard version". If retrofitting from "standard" to "extended life" camshafts, Euclid strongly recommends replacing both cams on a single axle or all cams on tandem axles to promote a balanced brake condition.

EUCLID NO.	HEAD END	REPLACES	A	B	C	APPLICATION & GENERAL INFORMATION
E-5496	LH	Eaton 7-806654	23-3/4"	21-7/16"	2-5/32"	
E-5497	RH	Eaton 7-806655				
E-5494	LH	Eaton 808078	19-1/2"	17-3/16"		
E-5495	RH	Eaton 808079				

FOR EATON TRAILER AXLES WITH 16-1/2" "ES" "EXTENDED SERVICE" BRAKES

Use Brake Repair Kit:
"ES" I **E-5481A**
"ES" II **E-10244**

Use Camshaft Repair Kit:
E-2696A

1 1/2" Dia. - 28 Spline

All Euclid Cam Lengths are measured from **under Cam Head to beginning of Lock Ring Groove.**

Nominal Head Dimension - 1 1/8"



Important Note: These cams are "extended life" versions of this manufacturer's "standard version". If retrofitting from "standard" to "extended life" camshafts, Euclid strongly recommends replacing both cams on a single axle or all cams on tandem axles to promote a balanced brake condition.

EUCLID NO.	HEAD END	REPLACES	A	B	APPLICATION & GENERAL INFORMATION
E-9057	LH	Eaton 7-810538	19-1/2"	2-5/32"	
E-9058	RH	Eaton 7-810539			
E-9059	LH	Eaton 810025	23-3/4"	2-7/32"	
E-9060	RH	Eaton 810026			

BRAKE CAMSHAFTS — TRAILER AXLE

FOR FRUEHAUF "PRO-PAR" TRAILER AXLES WITH 12-1/4" BRAKES

Use Camshaft Repair Kit:
E-2090
E-2122 (Old Style)
 Use Brake Repair Kit:
E-2286

1 5/8" Dia. - 37 Spline

All Euclid Cam Lengths are measured from under Cam Head to beginning of Lock Ring Groove.

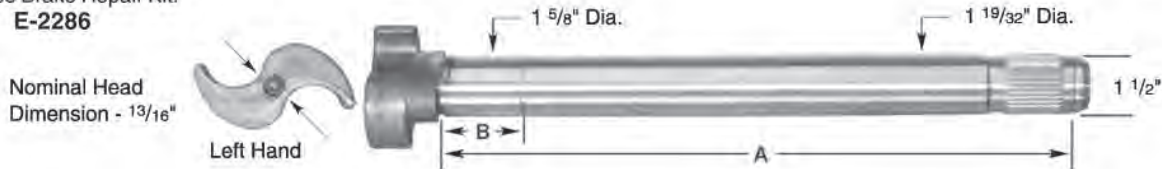

EUCLID NO.	HEAD END	REPLACES	A	B	APPLICATION & GENERAL INFORMATION
E-4890	LH	Fruehauf ACD-002193-006	21-3/16"	2-5/32"	
E-4891	RH	Fruehauf ACD-002193-005			

FOR FRUEHAUF "PRO-PAR" TRAILER AXLES WITH 16-1/2" BRAKES

Use Camshaft Repair Kit:
E-2090
E-2122 (Old Style)

Use Brake Repair Kit:
E-3710HD or
E-4880SHD

1 1/2" Dia. - 28 Spline

All Euclid Cam Lengths are measured from under Cam Head to beginning of Lock Ring Groove.

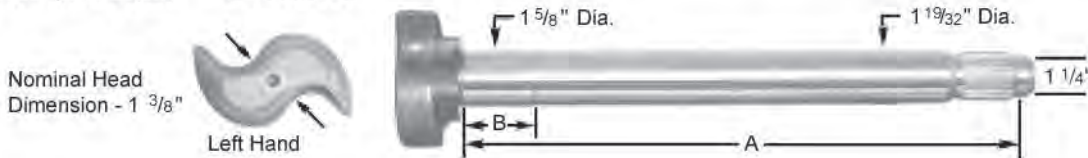

EUCLID NO.	HEAD END	REPLACES	A	B	APPLICATION & GENERAL INFORMATION
E-9761	LH	Fruehauf APA-000998-001	16-1/8"	2-5/32"	
E-9762	RH	Fruehauf APA-000998-002			

FOR FRUEHAUF "PRO-PAR" TRAILER AXLES WITH 16-1/2" BRAKES

Use Brake Repair Kit:
E-3710HD or
E-4880SHD

Use Camshaft Repair Kit:
E-2090
E-2122 (Old Style)

1 5/8" Dia. - 37 Spline

All Euclid Cam Lengths are measured from under Cam Head to beginning of Lock Ring Groove.

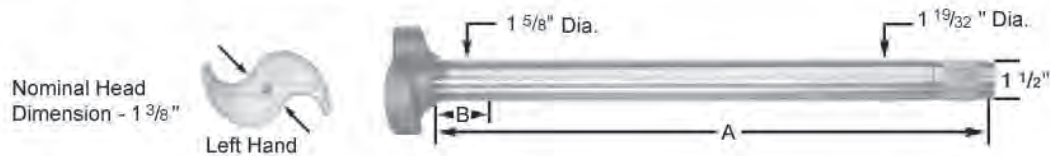

EUCLID NO.	HEAD END	REPLACES	A	B	APPLICATION & GENERAL INFORMATION
E-1563	LH	Fruehauf AXA-000420-001			
E-1564	RH	Fruehauf AXA-000420-002	16-1/8"		
E-2099	LH	Fruehauf AXA-000420-003		2-5/32"	For 16-1/2" Fruehauf Brakes. Extra long for use with Air Ride Suspension. Use with E-1574HD 37 Serration Slack Adjuster.
E-2100	RH	Fruehauf AXA-000420-004	21-1/8"		
E-3861	LH	Fruehauf AXA-000420-006			Longer length for Air Ride suspensions.
E-3862	RH	Fruehauf AXA-000420-005	23-7/8"	2-7/32"	

BRAKE CAMSHAFTS — TRAILER AXLE

FOR MERITOR TRAILER AXLES WITH 12-1/4" BRAKES

Use Camshaft Repair Kit:

E-3520A
E-3520AHD or
E-3989AHD

Use Brake Repair Kit:

E-3484

1 1/2" Dia. - 10 Spline

All Euclid Cam Lengths are measured from under Cam Head to beginning of Lock Ring Groove.

Nominal Head Dimension - 11/16"



Left Hand



EUCLID NO.	HEAD END	REPLACES	A	B	APPLICATION & GENERAL INFORMATION
E-4900	LH	Meritor 2210G6169	20-3/8"	1-23/32"	
E-4901	RH	Meritor 2210H6170			

FOR MERITOR TRAILER AXLES WITH 12-1/4" BRAKES

Use Camshaft Repair Kit:

E-3520A
E-3520AHD or
E-3989AHD

Use Brake Repair Kit:

E-3484

1 1/2" Dia. - 28 Spline

All Euclid Cam Lengths are measured from under Cam Head to beginning of Lock Ring Groove.

Nominal Head Dimension - 11/16"



Left Hand



EUCLID NO.	HEAD END	REPLACES	A	B	APPLICATION & GENERAL INFORMATION
E-3516	LH	Meritor 2210T5246	20-3/8"		
E-3517	RH	Meritor 2210D6166		1-23/32"	
E-9087	LH	Meritor 2210E6167	23-7/32"		
E-9088	RH	Meritor 2210F6168			

FOR MERITOR TRAILER AXLES WITH 15" "QPLUS" BRAKES

1 1/2" Dia. - 28 Spline

All Euclid Cam Lengths are measured from under Cam Head to beginning of Lock Ring Groove.

Nominal Head Dimension - 1"



Left Hand



EUCLID NO.	HEAD END	REPLACES	A	B	APPLICATION & GENERAL INFORMATION
E-11958	LH	Meritor 2210B7958	23-3/8"	1-63/64"	Contact Florence Information Services for Repair Kit details.
E-11959	RH	Meritor 2210C7959			

BRAKE CAMSHAFTS — TRAILER AXLE

FOR MERITOR 4000-6000 SERIES TRAILER AXLES WITH 16-1/2" BRAKES

Use Camshaft Repair Kit:
E-3520A
E-3520AHD or
E-3989AHD
 Use Brake Repair Kit:
E-2769HD

1 1/2" Dia. - 10 Spline

All Euclid Cam Lengths are measured from under Cam Head to beginning of Lock Ring Groove.



"Q" Plus
 Nominal Head
 Dimension - 1 3/16"



EUCLID NO.	HEAD END	REPLACES	A	B	APPLICATION & GENERAL INFORMATION
E-2447A	LH	Meritor R607066	17-5/16"		
E-2448A	RH	Meritor R607065			
E-2449A	LH	Meritor R607070	20-13/32"	1-45/64"	
E-2450A	RH	Meritor R607069			
E-2451A	LH	Meritor R607068	24-1/16"		
E-2452A	RH	Meritor R607067			

FOR MERITOR 4000-6000 SERIES TRAILER AXLES WITH 16-1/2" "Q PLUS" BRAKES

Use Camshaft Repair Kit:
E-3520A
E-3520AHD or
E-3989AHD
 Use Brake Repair Kit:
E-2769HD

1 1/2" Dia. - 28 Spline

All Euclid Cam Lengths are measured from under Cam Head to beginning of Lock Ring Groove.

"Q" Plus
 Nominal Head
 Dimension - 1 3/16"



EUCLID NO.	HEAD END	REPLACES	A	B	APPLICATION & GENERAL INFORMATION
E-2441B	LH	Meritor 2210R8156	17-5/16"		
E-2442B	RH	Meritor 2210Q8155			
E-2443B	LH	Meritor 2210T8158	20-13/32"	1-45/64"	Q Plus, Q and P brakes. Cast spiders with press-in bushings. Fabricated spiders with weld-on bushings.
E-2444B	RH	Meritor 2210S8157			
E-2445B	LH	Meritor 2210V8160	24-1/16"		
E-2446B	RH	Meritor 2210U8159			

FOR MERITOR TRAILER AXLES WITH 16-1/2" "Q PLUS" BRAKES

Use Camshaft Repair Kit:
E-9078HD (Press-in spider bushings)
E-9079HD (Bolt-on spider bushings)
 Use Brake Repair Kit:
E-2769HD

1 1/2" Dia. - 28 Spline

All Euclid Cam Lengths are measured from under Cam Head to beginning of Lock Ring Groove.

"Q" Plus
 Nominal Head
 Dimension - 1 3/16"

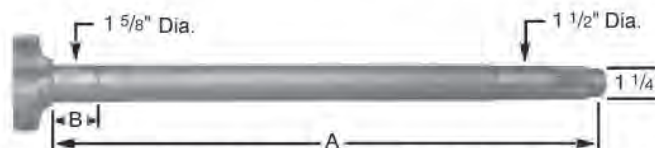

Important Note: These cams are "extended life" versions of this manufacturer's "standard version". If retrofitting from "standard" to "extended life" camshafts, Euclid strongly recommends replacing both cams on a single axle or all cams on tandem axles to promote a balanced brake condition.

EUCLID NO.	HEAD END	REPLACES	A	B	APPLICATION & GENERAL INFORMATION
E-5507	RH	Meritor 2210B6866	17-5/16"		Can be used with cast or fabricated spiders and all spider bushings. E-9075 Washer must be used when using these camshafts with nylon or metal press-in spider bushings.
E-5506	LH	Meritor 2210C6867			
E-5508	LH	Meritor 2210G6871	20-13/32"	1-31/32"	
E-5509	RH	Meritor 2210F6870			
E-5510	LH	Meritor 2210E6869	24-1/16"		
E-5511	RH	Meritor 2210D6868			

BRAKE CAMSHAFTS — TRAILER AXLE

FOR SPICER (STD. FORGE) TRAILER AXLES WITH 12-1/4" BRAKES

Use Camshaft Repair Kit:
E-2469 (Nylon Spider Bushing)
E-5307 (Bronze Spider Bushing)
 Use Brake Repair Kit:
 Check Application

1 1/2" Dia. - 10 Spline

All Euclid Cam Lengths are measured from **under Cam Head to beginning of Lock Ring Groove.**

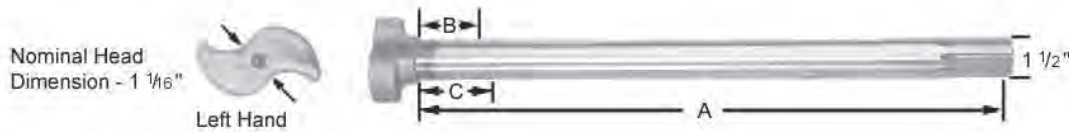

EUCLID NO.	HEAD END	REPLACES	A	B	C	APPLICATION & GENERAL INFORMATION
E-9743	LH	Dana/Spicer M12WK101-11	18-7/8"			Spicer (Dana) and Std. Forge 12-1/4" x 5-1/2" and 12-1/4" x 7-1/2" Brakes. Also can be used for Dexter 12-1/4" Brakes.
		Dana/Spicer M12WK107-1				
		Std. Forge 202103191L				
E-9744	RH	Dana/Spicer M12WK100-11	20-1/2"			
		Dana/Spicer M12WK106-1				
		Std. Forge 202103191R				
E-5096	LH	Dana/Spicer M12WK107-3 Std. Forge 202103-206L	22"			
E-5097	RH	Dana/Spicer M12WK106-3 Std. Forge 202103-206R				
E-1411	LH	Dana/Spicer M12WK107-6	21-1/8"			
		Std. Forge 202103-213L				
		Std. Forge UB-22-64L				
E-1410	RH	Dana/Spicer M12WK106-6	23-1/4"			
		Std. Forge 202103-213R				
		Std. Forge UB-22-64R				
E-9745	LH	Dana/Spicer M12WK107-7 Std. Forge 202103222L				
E-9746	RH	Dana/Spicer M12WK100-16 Std. Forge 202103222R		2-7/32"	2-21/32"	
E-1423	LH	Dana/Spicer 17-691	23-1/4"			
		Std. Forge 202103-233L				
		Std. Forge UB-24-15L				
E-1422	RH	Dana/Spicer M12WK100-17	26-1/2"			
		Std. Forge 202103-233R				
		Std. Forge UB-24-15R				
E-1421	LH	Dana/Spicer M12WK101-19	24-5/8"			
		Std. Forge 202103-241L				
		Std. Forge UB-22-23L				
E-1420	RH	Std. Forge 202103-241R Std. Forge UB-22-23R				
E-2793	LH	Dana/Spicer M12WK101-18 Std. Forge 202103-247L				
E-2792	RH	Dana/Spicer M12WK100-18	26-1/2"			
		Std. Forge 202103-247R				
		Dana/Spicer M12WK101-22 Dana/Spicer M12WK107-13				
E-9747	LH	Dana/Spicer M12WK100-22 Dana/Spicer M12WK106-13				

BRAKE CAMSHAFTS — TRAILER AXLE

FOR SPICER TRAILER AXLES WITH 12-1/4" BRAKES - "NEW" HEAD DESIGN REPLACES "FAST-RISE" CAMSHAFT HEAD STYLE

Use Camshaft Repair Kit:
E-2469 (Nylon Spider Bushing)
E-5307 (Bronze Spider Bushing)

1 1/2" Dia. - 10 Spline

All Euclid Cam Lengths are measured from under Cam Head to beginning of Lock Ring Groove.



EUCLID NO.	HEAD END	REPLACES	A	B	C	APPLICATION AND GENERAL INFORMATION
E-9263	LH	Dana/Spicer M12WKL10-163	16-1/8"			<p>APPLICATION AND GENERAL INFORMATION</p> <p>Spicer has changed the head design of these camshafts. The new heads are marked: "0794L" and "0794R". Spicer did not change their part numbers for these cams, so pay attention to the head markings! WARNING: These camshafts are for use with fabricated brakes shoes only! DO NOT use these new camshafts with cast brake shoe or fabricated closed roller-end brake shoes. Euclid fabricated open roller end brake shoe numbers are: E-2393A, E-2394A, and E-5303A. WARNING: E-586, 1-1/2" diameter, Rollers must be used with this new head design. E-586 rollers are now available in Brake Repair Kits E-9281, E-9282 and E-9283. WARNING: These camshafts should not be used in conjunction with old "Fast-Rise" camshafts on the same axle. The rate of brake application is different between the two head designs.</p>
E-9264	RH	Dana/Spicer M12WKR10-163				
E-9751	LH	Dana/Spicer M12WKL10-175	17-3/8"			
E-9752	RH	Dana/Spicer M12WKR10-175				
E-9749	LH	Dana/Spicer M12WKL10-182	18"			
E-9750	RH	Dana/Spicer M12WKR10-182				
E-9265	LH	Dana/Spicer M12WKL10-191	18-7/8"			
E-9266	RH	Dana/Spicer M12WKR10-191				
E-9267	LH	Dana/Spicer M12WKL10-206	20-1/2"			
E-9268	RH	Dana/Spicer M12WKR10-206				
E-9269	LH	Dana/Spicer M12WKL10-214	21-1/4"			
E-9270	RH	Dana/Spicer M12WKR10-214				
E-9271	LH	Dana/Spicer M12WKL10-222	22"			
E-9272	RH	Dana/Spicer M12WKR10-222				
E-9273	LH	Dana/Spicer M12WKL10-233	23-1/8"	2-7/32"	2-21/32"	
E-9274	RH	Dana/Spicer M12WKR10-233				
E-9275	LH	Dana/Spicer M12WKL10-236	23-1/2"			
E-9276	RH	Dana/Spicer M12WKR10-236				
E-9277	LH	Dana/Spicer M12WKL10-241	23-7/8"			
E-9278	RH	Dana/Spicer M12WKR10-241				
E-9279	LH	Dana/Spicer M12WKL10-264	26-1/4"			
E-9280	RH	Dana/Spicer M12WKR10-264				

BRAKE CAMSHAFTS — TRAILER AXLE

FOR SPICER TRAILER AXLES WITH 12-1/4" BRAKES - "NEW" HEAD DESIGN REPLACES "FAST-RISE" CAMSHAFT HEAD STYLE

Use Camshaft Repair Kit:

E-2469 (Nylon Spider Bushing) 1 1/2" Journal

E-5307 (Bronze Spider Bushing) 1 1/2" Journal

1 1/2" Dia. - 28 Spline

All Euclid Cam Lengths are measured from **under Cam Head to beginning of Lock Ring Groove.**

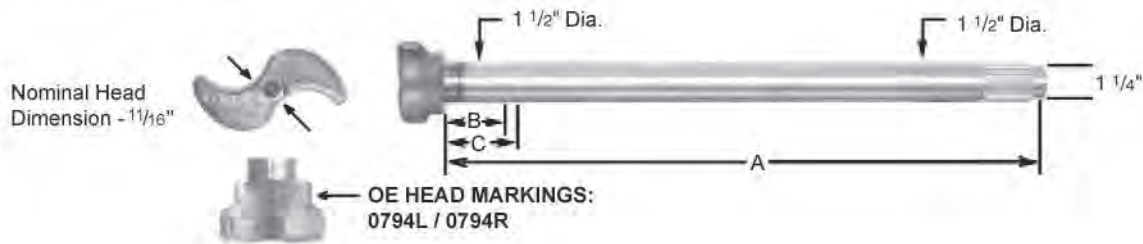

EUCLID NO.	HEAD END	REPLACES	A	B	C
E-9753	LH	Dana/Spicer M12WKL20-205	20-7/16"		
E-9754	RH	Dana/Spicer M12WKR20-205			
E-9755	LH	Dana/Spicer M12WKL20-214	21-5/16"		
E-9756	RH	Dana/Spicer M12WKR20-214			
E-9757	LH	Dana/Spicer M12WKL20-222	22-1/16"	2-7/32"	2-21/32"
E-9758	RH	Dana/Spicer M12WKR20-222			
E-9759	LH	Dana/Spicer M12WKL20-233	23-3/16"		
E-9760	RH	Dana/Spicer M12WKR20-233			

APPLICATION AND GENERAL INFORMATION

Spicer has changed the head design of these camshafts. The new heads are marked: "0794L" and "0794R". Spicer did not change their part numbers for these cams, so pay attention to the head markings! **WARNING:** These camshafts are for use with fabricated brake shoes only! **DO NOT** use these new camshafts with cast brake shoe or fabricated closed roller-end brake shoes. Euclid fabricated open roller end brake shoe numbers are: E-2393A, E-2394A, and E-5303A. **WARNING:** E-586, 1-1/2" diameter, Rollers must be used with this new head design. E-586 rollers are now available in Brake Repair Kits E-9281, E-9282 and E-9283. **WARNING:** These camshafts should not be used in conjunction with old "Fast-Rise" camshafts on the same axle. The rate of brake application is different between the two head designs.

BRAKE CAMSHAFTS — TRAILER AXLE

FOR SPICER TRAILER AXLES WITH 12-1/4" BRAKES - "NEW" HEAD DESIGN REPLACES "FAST-RISE" CAMSHAFT HEAD STYLE

Use Camshaft Repair Kit:
E-9790A 1 5/8" Journal

1 1/2" Dia. - 28 Spline

All Euclid Cam Lengths are measured from **under Cam Head to beginning of Lock Ring Groove.**

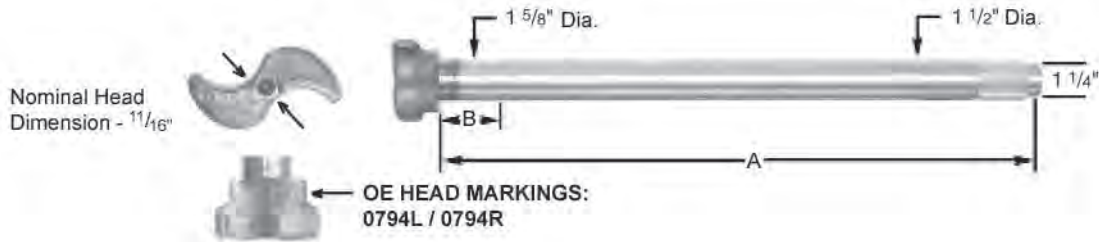

EUCLID NO.	HEAD END		REPLACES	A	B
E-10901	LH	Dana/Spicer	M12WKL25-206	20-9/16"	2-7/32"
E-10902	RH	Dana/Spicer	M12WKR25-206		
E-10903	LH	Dana/Spicer	M12WKL25-214	21-5/16"	
E-10904	RH	Dana/Spicer	M12WKR25-214		
E-10905	LH	Dana/Spicer	M12WKL25-233	23-3/16"	
E-10906	RH	Dana/Spicer	M12WKR25-233		
E-10907	LH	Dana/Spicer	M12WKL25-241	23-15/16"	
E-10908	RH	Dana/Spicer	M12WKR25-241		

APPLICATION AND GENERAL INFORMATION

Spicer has changed the head design of these camshafts. The new heads are marked: "0794L" and "0794R". Spicer did not change their part numbers for these cams, so pay attention to the head markings! **WARNING:** These camshafts are for use with fabricated brakes shoes only! **DO NOT** use these new camshafts with cast brake shoe or fabricated closed roller-end brake shoes. Euclid fabricated open roller end brake shoe numbers are: E-2393A, E-2394A, and E-5303A. **WARNING:** E-586, 1-1/2" diameter, Rollers must be used with this new head design. E-586 rollers are now available in Brake Repair Kits E-9281, E-9282 and E-9283. **WARNING:** These camshafts should not be used in conjunction with old "Fast-Rise" camshafts on the same axle. The rate of brake application is different between the two head designs.

BRAKE CAMSHAFTS — TRAILER AXLE

FOR SPICER (HAYES DANA) TRAILER AXLES WITH 16-1/2" BRAKES

Use Camshaft Repair Kit:
E-2287

Use Brake Repair Kit:
Check Application

1 1/2" Dia. - 10 Spline

All Euclid Cam Lengths are measured from **under Cam Head to beginning of Lock Ring Groove.**

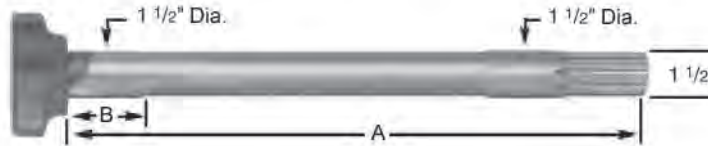

EUCLID NO.	HEAD END	REPLACES	A	B	APPLICATION & GENERAL INFORMATION
E-9709	LH	Dana/Spicer M16WK102-5 Std. Forge 202100157L	15-5/8"		
E-9710	RH	Dana/Spicer M16WK103-5 Std. Forge 202100157R	15-5/8"	2-7/32"	
E-7217	LH		26-1/4"		
E-7218	RH				
E-7219	LH		26-1/2"		
E-7220	RH				

FOR SPICER TRAILER AXLES WITH 16-1/2" BRAKES

Use Camshaft Repair Kit:
E-2287

Use Brake Repair Kit:
E-2769HD

1 1/2" Dia. - 28 Spline

All Euclid Cam Lengths are measured from **under Cam Head to beginning of Lock Ring Groove.**

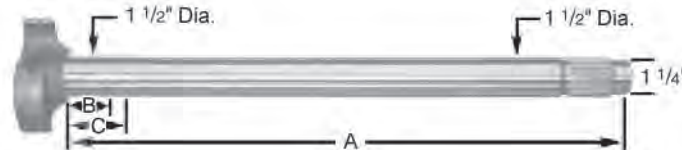
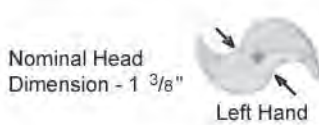

EUCLID NO	HEAD END	REPLACES	A	B	C	APPLICATION & GENERAL INFORMATION
E-9725	LH	Dana/Spicer M16WK104-10	17-3/8"			
E-9726	RH	Dana/Spicer M16WK105-10				
E-3854	LH	Dana/Spicer M16WK104-17	20-3/8"			Standard length
E-3855	RH	Dana/Spicer M16WK105-17				
E-6884	LH	Dana/Spicer M16WK104-23 Meritor R607189 Dana/Spicer 16656	22-7/8"	1-5/8"	2-7/32"	
E-6885	RH	Dana/Spicer M16WK105-23 Meritor R607190				
E-3856	LH	Dana/Spicer M16WK104-25	23-7/16"			Longer length for Air Ride suspensions
E-3857	RH	Dana/Spicer M16WK105-25				

BRAKE CAMSHAFTS — TRAILER AXLE

FOR SPICER TRAILER AXLES WITH 16-1/2" "XL" "XTRALIFE" BRAKES

Use Brake Repair Kit:
"XL" E-5515
Standard "Q" E-2769HD

Use Camshaft Repair Kit:
E-2287

1 1/2" - 10 Spline

All Euclid Cam Lengths are measured from under Cam Head to beginning of Lock Ring Groove.



Important Note: These cams are "extended life" versions of this manufacturer's "standard version". If retrofitting from "standard" to "extended life" camshafts, Euclid strongly recommends replacing both cams on a single axle or all cams on tandem axles to promote a balanced brake condition.

EUCLID NO.	HEAD END	REPLACES	A	B	C	APPLICATION & GENERAL INFORMATION
E-5516	LH	Dana/Spicer M16WKL10-175	17-3/8"			
E-5517	RH	Dana/Spicer M16WKR10-175				
E-9739	LH	Dana/Spicer M16WKL10-196	19-1/2"			
E-9740	RH	Dana/Spicer M16WKR10-196				
E-5518	LH	Dana/Spicer M16WKL10-205	20-3/8"			
E-5519	RH	Dana/Spicer M16WKR10-205				
E-6101	LH	Dana/Spicer M16WKL10-231	22-7/8"			
E-6102	RH	Dana/Spicer M16WKR10-231		1-5/8"	2-7/32"	
E-5520	LH	Dana/Spicer M16WKL10-236	23-1/2"			
E-5521	RH	Dana/Spicer M16WKR10-236				
E-9727	LH	Dana/Spicer M16WKL10-242	24"			
E-9728	RH	Dana/Spicer M16WKR10-242				
E-6103	LH	Dana/Spicer M16WKL10-245	24-3/8"			
E-6104	RH	Dana/Spicer M16WKR10-245				
E-9741	LH	Dana/Spicer M16WKL10-264	26-1/4"			
E-9742	RH	Dana/Spicer M16WKR10-264				

FOR SPICER TRAILER AXLES WITH 16-1/2" "XL" "XTRALIFE" BRAKES

Use Brake Repair Kit:
"XL" E-5515
Standard "Q" E-2769HD

Use Camshaft Repair Kit:
E-2287

1 1/2" - 28 Spline

All Euclid Cam Lengths are measured from under Cam Head to beginning of Lock Ring Groove.

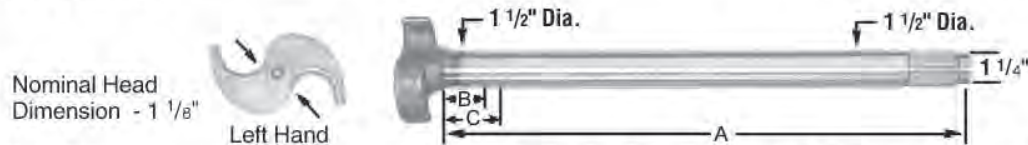

Important Note: These cams are "extended life" versions of this manufacturer's "standard version". If retrofitting from "standard" to "extended life" camshafts, Euclid strongly recommends replacing both cams on a single axle or all cams on tandem axles to promote a balanced brake condition.

EUCLID NO.	HEAD END	REPLACES	A	B	C	APPLICATION & GENERAL INFORMATION
E-9096	LH	Dana/Spicer M16WKL20-173	17-3/16"	1-5/8"	2-7/32"	
E-9097	RH	Dana/Spicer M16WKR20-173				
E-5522	LH	Dana/Spicer M16WKL20-175	17-7/16"			
E-5523	RH	Dana/Spicer M16WKR20-175				
E-5524	LH	Dana/Spicer M16WKL20-205	20-7/16"			
E-5525	RH	Dana/Spicer M16WKR20-205				
E-9098	LH	Dana/Spicer M16WKL20-231	22-15/16"			
E-9099	RH	Dana/Spicer M16WKR20-231				
E-5526	LH	Dana/Spicer M16WKL20-236	23-9/16"			
E-5527	RH	Dana/Spicer M16WKR20-236				
E-9100	LH	Dana/Spicer M16WKL20-242	24-1/16"			
E-9101	RH	Dana/Spicer M16WKR20-242				
E-9729	LH	Dana/Spicer M16WKL20-271	26-15/16"			
E-9730	RH	Dana/Spicer M16WKR20-271				

BRAKE CAMSHAFTS — TRAILER AXLE

FOR SPICER TRAILER AXLES WITH 16-1/2" "XL" "XTRALIFE" BRAKES WITH 1-5/8" BEARING JOURNAL

Use Brake Repair Kit:
"XL" E-5515
Standard "Q" E-2769HD

Use Camshaft Repair Kit:
E-9790A or
E-11910

1 1/2" - 28 Spline

All Euclid Cam Lengths are measured from **under**
Cam Head to beginning of Lock Ring Groove.



Important Note: These cams are "extended life" versions of this manufacturer's "standard version". If retrofitting from "standard" to "extended life" camshafts, Euclid strongly recommends replacing both cams on a single axle or all cams on tandem axles to promote a balanced brake condition.

EUCLID NO.	HEAD END		REPLACES	A	B	APPLICATION & GENERAL INFORMATION
E-9731	LH	Dana/Spicer	M16WKL25-175	17-7/16"		
E-9732	RH	Dana/Spicer	M16WKR25-175			
E-9733	LH	Dana/Spicer	M16WKL25-205	20-7/16"		
E-9734	RH	Dana/Spicer	M16WKR25-205			
E-11856	LH	Dana/Spicer	M16WKL25-227	22-5/8"		
E-11857	RH	Dana/Spicer	M16WKR25-227			
E-11858	LH	Dana/Spicer	M16WKL25-231	22-7/8"		
E-11859	RH	Dana/Spicer	M16WKR25-231			
E-9735	LH	Dana/Spicer	M16WKL25-236	23-9/16"	2-1/4"	
E-9736	RH	Dana/Spicer	M16WKR25-236			
E-10909	LH	Dana/Spicer	M16WKL25-242	24-1/8"		
E-10910	RH	Dana/Spicer	M16-WKR25-242			
E-11860	LH	Dana/Spicer	M16WKL25-264	26-1/4"		
E-11861	RH	Dana/Spicer	M16WKR25-264			
E-9737	LH	Dana/Spicer	M16WKL25-271	26-15/16"		
E-9738	RH	Dana/Spicer	M16WKR25-271			
E-11862	LH	Dana/Spicer	M16WKL25-304	30-1/4"		
E-11863	RH	Dana/Spicer	M16WKR25-304			

CAMSHAFT REPAIR KITS

E-11910 For 12-1/4" and 16-1/2" Dia. Cam Brakes

APPLICATION & GENERAL INFORMATION
 FOR SPICER (DANA) 12-1/4" and 16-1/2" BRAKE WITH 1-5/8" CAM JOURNAL

Same as E-9790A except contains cam support brackets.

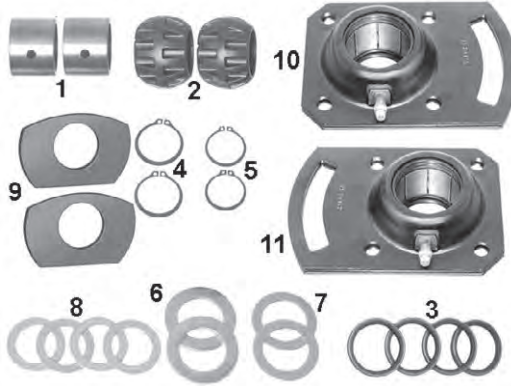

EUCLID NO.	ITEM	QTY	DESCRIPTION
E-9789	1	2	Camshaft Bushing
E-9792A	2	2	Camshaft Bushing
E-2405	3	4	Camshaft Seal
E-1569	4	2	Camshaft Lock Ring
E-801	5	2	Lock Ring
E-10800	6	2	Cam Washer
E-580	7	2	Camshaft Spacer Washer
E-1113	8	4	Washer
E-10801	9	2	Cam Washer
E-11445	10	1	Camshaft Support Bracket
E-11446	11	1	Camshaft Support Bracket

E-2469 For 12-1/4" Dia. Cam Brakes

APPLICATION & GENERAL INFORMATION
 FOR LATE MODEL SPICER and STANDARD FORGE AXLES

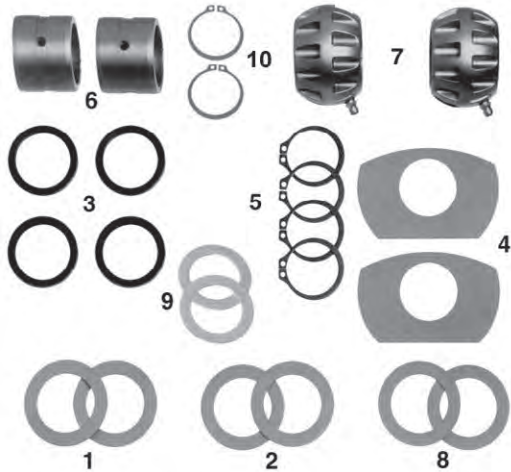

EUCLID NO.	ITEM	QTY	DESCRIPTION
E-580	1	2	Camshaft Spacer Washer
E-581	2	2	Camshaft Spacer Washer
E-1416A	3	4	Camshaft Seal
E-2404	4	2	Camshaft "D" Washer
E-526	5	4	Camshaft Lock Ring
E-759	6	2	Camshaft Spider Bushing
E-2102	7	2	Camshaft Bushing
E-2409	8	2	Camshaft Spacer Washer
E-1113	9	2	Washer
E-801	10	2	Lock Ring

E-2469-2 For 12-1/4" Dia. Cam Brakes

APPLICATION & GENERAL INFORMATION
 FOR LATE MODEL SPICER and STANDARD FORGE AXLES

Half kit includes exactly half of Kit E-2469 for one wheel end.



EUCLID NO.	ITEM	QTY	DESCRIPTION
E-580	1	1	Camshaft Spacer Washer
E-581	2	1	Camshaft Spacer Washer
E-1416A	3	2	Camshaft Seal
E-2404	4	1	Camshaft "D" Washer
E-526	5	2	Camshaft Lock Ring
E-759	6	1	Camshaft Spider Bushing
E-2102	7	1	Camshaft Bushing
E-2409	8	1	Camshaft Spacer Washer
E-1113	9	1	Washer
E-801	10	1	Lock Ring

CAMSHAFT REPAIR KITS

E-2494 For 12-1/4" Dia. Cam Brakes

APPLICATION & GENERAL INFORMATION
FOR LATE MODEL EATON AXLES

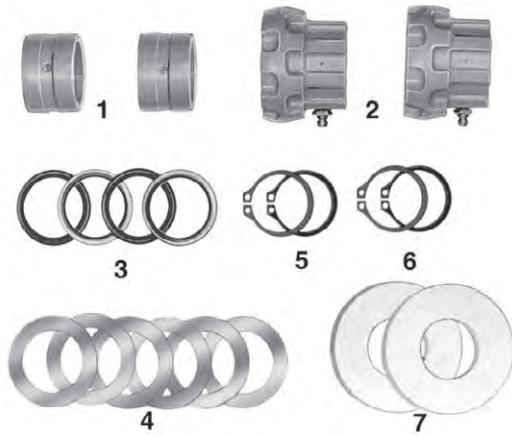

EUCLID NO.	ITEM	QTY	DESCRIPTION
E-536	1	2	Camshaft Bushing
E-1385	2	2	Camshaft Bushing
E-1416A	3	4	Camshaft Seal
E-580	4	6	Camshaft Spacer Washer
E-1569	5	2	Camshaft Lock Ring
E-526	6	2	Camshaft Lock Ring
E-3473	7	2	Camshaft Spacer Washer

E-2526 For 12-1/4" Dia. Cam Brakes

APPLICATION & GENERAL INFORMATION
FOR SPICER and STANDARD FORGE AXLES

Use the shorter E-536 Bushing in cam support bracket and the longer E-759 Bushing in the spider.

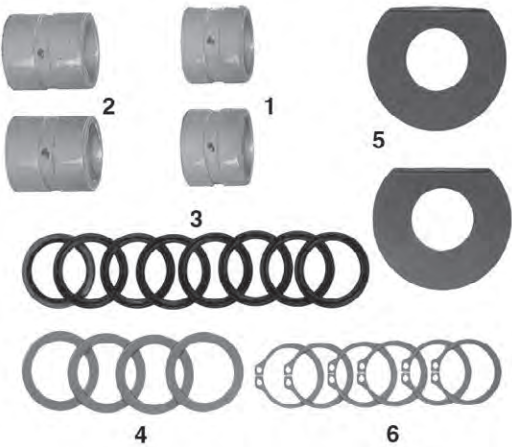

EUCLID NO.	ITEM	QTY	DESCRIPTION
E-536	1	2	Camshaft Bushing
E-759	2	2	Camshaft Spider Bushing
E-1416A	3	8	Camshaft Seal
E-564	4	4	Camshaft Spacer Washer
E-1408	5	2	Camshaft Washer
E-526	6	6	Camshaft Lock Ring

E-5307 For 12-1/4" Dia. Cam Brakes

APPLICATION & GENERAL INFORMATION
FOR SPICER (DANA) 12-1/4" "U" BRAKE

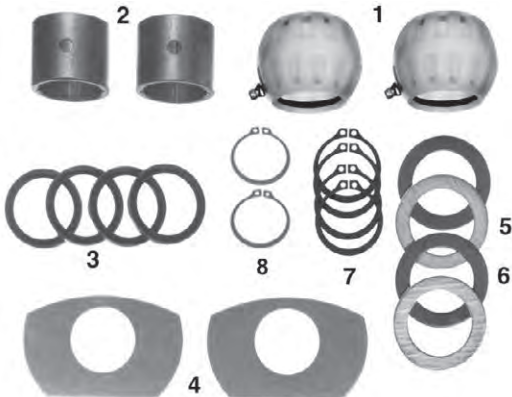

EUCLID NO.	ITEM	QTY	DESCRIPTION
E-2102	1	2	Camshaft Bushing
E-807	2	2	Bronze Camshaft Bushing
E-1416A	3	4	Camshaft Seal
E-2409	4	2	Camshaft Spacer Washer
E-580	5	2	Camshaft Spacer Washer
E-2404	6	2	Camshaft "D" Washer
E-526	7	4	Camshaft Lock Ring
E-801	8	2	Lock Ring

CAMSHAFT REPAIR KITS

E-5307-2 For 12-1/4" Dia. Cam Brakes

APPLICATION & GENERAL INFORMATION

FOR SPICER (DANA) 12-1/4" "U" BRAKE. Half kit includes exactly half of Kit E-5307 for one wheel end.



EUCLID NO.	ITEM	QTY	DESCRIPTION
E-2102	1	1	Camshaft Bushing
E-807	2	1	Bronze Camshaft Bushing
E-1416A	3	2	Camshaft Seal
E-2409	4	1	Camshaft Spacer Washer
E-580	5	1	Camshaft Spacer Washer
E-2404	6	1	Camshaft "D" Washer
E-526	7	2	Camshaft Lock Ring
E-801	8	1	Lock Ring

E-9790A For 12-1/4" and 16-1/2" Dia. Cam Brakes

APPLICATION & GENERAL INFORMATION

FOR SPICER (DANA) 12-1/4" and 16-1/2" BRAKE WITH 1-5/8" CAM JOURNAL

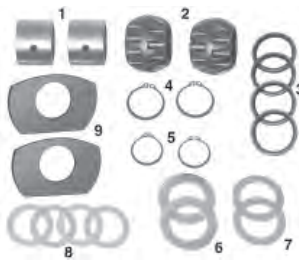

EUCLID NO.	ITEM	QTY	DESCRIPTION
E-9789	1	2	Camshaft Bushing
E-9792A	2	2	Camshaft Bushing
E-2405	3	4	Camshaft Seal
E-1569	4	2	Camshaft Lock Ring
E-801	5	2	Lock Ring
E-10800	6	2	Cam Washer
E-580	7	2	Camshaft Spacer Washer
E-1113	8	4	Washer
E-10801	9	2	Cam Washer

E-10846 For 14-1/2" Dia. Cam Brakes

APPLICATION & GENERAL INFORMATION

FOR MERITOR COACH 14-1/2" x 4" and 6" "W" SERIES



EUCLID NO.	ITEM	QTY	DESCRIPTION
E-667	1	4	Bronze Camshaft Bushing
E-654	2	4	Camshaft Seal
E-4736	3	2	Camshaft Lock Ring
E-10845	4	4	Camshaft Spacer Washer
E-3479	5	4	Camshaft Spacer Washer
E-10843	6	2	Camshaft Spacer Washer

E-10868 For 14-1/2" Dia. Cam Brakes

APPLICATION & GENERAL INFORMATION

FOR MERITOR COACH 14-1/2" x 8" and 10" "W" SERIES

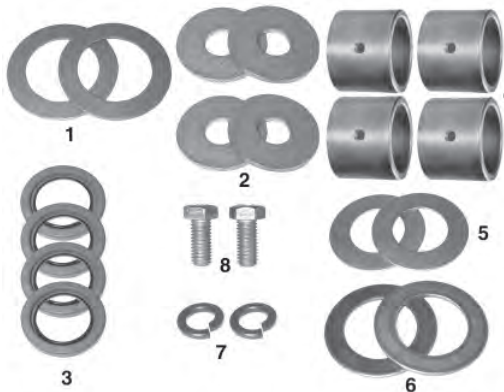

EUCLID NO.	ITEM	QTY	DESCRIPTION
E-3479	1	2	Camshaft Spacer Washer
E-10845	2	4	Camshaft Spacer Washer
E-10848	3	4	Camshaft Seal
E-667	4	4	Bronze Camshaft Bushing
E-10843	5	2	Camshaft Spacer Washer
E-10851	6	2	Camshaft Spacer Washer
NSS*	7	2	Lockwasher
NSS*	8	2	Retainer Bolt

*Not Sold Separately

CAMSHAFT REPAIR KITS

E-10871 For 14-1/2" Dia. Cam Brakes

APPLICATION & GENERAL INFORMATION

MERITOR COACH 14-1/2" "W" SERIES BRAKE

For use with Meritor Coach "W" 10" Series Brake Shoe, Type 2

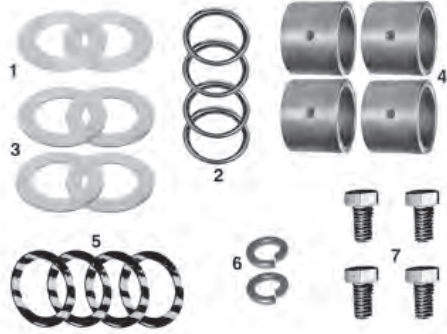

EUCLID NO.	ITEM	QTY	DESCRIPTION
E-10843	1	2	Camshaft Spacer Washer
E-654	2	4	Camshaft Seal
E-10857	3	4	Camshaft Head Washer
E-667	4	4	Bronze Camshaft Bushing
E-10851	5	4	Camshaft Spacer Washer
NSS*	6	2	Lockwasher
NSS*	7	4	Retainer Bolt

E-10872 For 14-1/2" Dia. Cam Brakes

APPLICATION & GENERAL INFORMATION

MERITOR COACH 14-1/2" "W" SERIES BRAKE

For use with Meritor Coach "W" 10" Series Brake Shoe, Type 3

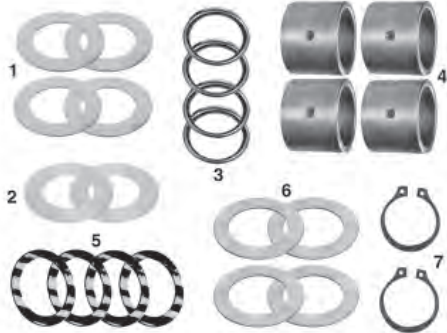

EUCLID NO.	ITEM	QTY	DESCRIPTION
E-10857	1	4	Camshaft Head Washer
E-10843	2	2	Camshaft Spacer Washer
E-654	3	4	Camshaft Seal
E-667	4	4	Bronze Camshaft Bushing
E-3479	5	4	Camshaft Spacer Washer
E-10845	6	4	Camshaft Spacer Washer
E-4736	7	2	Camshaft Lock Ring

E-10897 For 15" and 16-1/2" Dia. Cam Brakes

APPLICATION & GENERAL INFORMATION

FOR EATON "ES"

Eaton 15" "Reduced Envelope" Brakes and Drive Axles with 16-1/2" "ES" "Extended Service" Brakes

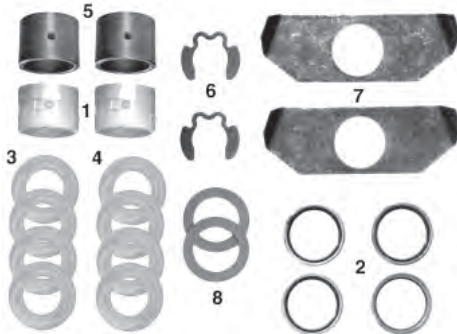

EUCLID NO.	ITEM	QTY	DESCRIPTION
E-536	1	2	Camshaft Bushing
E-1416	2	4	Camshaft Seal
E-1781	3	4	Camshaft Spacer Washer
E-1782	4	4	Camshaft Spacer Washer
E-667	5	2	Bronze Camshaft Bushing
E-3234	6	2	Camshaft Snap Ring
E-5482	7	2	Camshaft Wear Washer
E-580	8	2	Camshaft Spacer Washer

E-3993B For 15" and 16-1/2" Dia. Cam Brakes

APPLICATION & GENERAL INFORMATION

FOR MERITOR 15 and 16-1/2" DRIVE AXLE "Q" and "Q PLUS" BRAKES

Contains E-3859 Rubber Camshaft Support Gasket. Contains New Style E-5512 Moly-impregnated Spider Bushing. Contains Lock Rings for Camshafts with narrow or wide grooves.

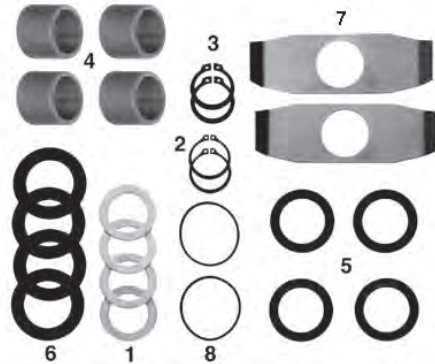

EUCLID NO.	ITEM	QTY	DESCRIPTION
E-1113	1	4	Washer
E-801	2	2	Lock Ring
E-5093	3	2	Camshaft Lock Ring
E-5512	4	4	Camshaft Bushing
E-654	5	4	Camshaft Seal
E-3479	6	4	Camshaft Spacer Washer
E-3478	7	2	Camshaft Wear Washer
E-3859	8	2	Camshaft Seal

*Not Sold Separately

CAMSHAFT REPAIR KITS

E-3993B-2 For 15" and 16-1/2" Dia. Cam Brakes

APPLICATION & GENERAL INFORMATION

FOR MERITOR 15 and 16-1/2" DRIVE AXLE "Q" and "Q PLUS" BRAKES

Contains E-3859 Rubber Camshaft Support Gasket. Contains New Style E-5512 Moly-impregnated Spider Bushing. Contains Lock Rings for Camshafts with narrow or wide grooves. Contains half of Kit E-3993B.

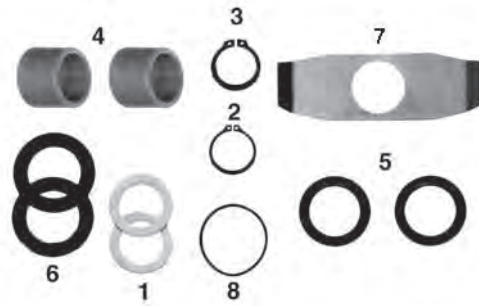

EUCLID NO.	ITEM	QTY	DESCRIPTION
E-1113	1	2	Washer
E-801	2	1	Lock Ring
E-5093	3	1	Camshaft Lock Ring
E-5512	4	2	Camshaft Bushing
E-654	5	2	Camshaft Seal
E-3479	6	2	Camshaft Spacer Washer
E-3478	7	1	Camshaft Wear Washer
E-3859	8	1	Camshaft Seal

E-5501 For 15" and 16-1/2" Dia. Cam Brakes

APPLICATION & GENERAL INFORMATION

FOR EATON 15" "REDUCED ENVELOPE" BRAKES AND DRIVE AXLES WITH 16-1/2" "ES" "EXTENDED SERVICE" BRAKES

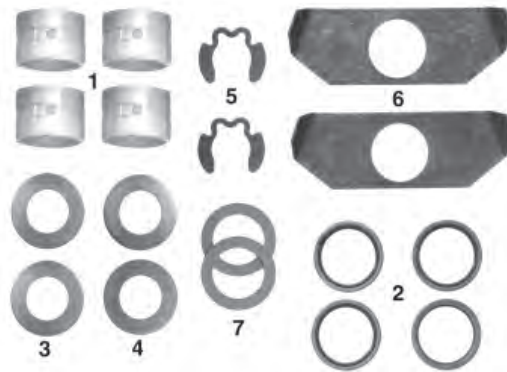

EUCLID NO.	ITEM	QTY	DESCRIPTION
E-536	1	4	Camshaft Bushing
E-1416	2	4	Camshaft Seal
E-1781	3	2	Camshaft Spacer Washer
E-1782	4	2	Camshaft Spacer Washer
E-3234	5	2	Camshaft Snap Ring
E-5482	6	2	Camshaft Wear Washer
E-580	7	2	Camshaft Spacer Washer

E-5501-2 For 15" and 16-1/2" Dia. Cam Brakes

APPLICATION & GENERAL INFORMATION

FOR EATON 15" "REDUCED ENVELOPE" BRAKES AND DRIVE AXLES WITH 16-1/2" "ES" "EXTENDED SERVICE" BRAKES

Half kit includes exactly half of Kit E-5501 for one wheel end.



EUCLID NO.	ITEM	QTY	DESCRIPTION
E-536	1	2	Camshaft Bushing
E-1416	2	2	Camshaft Seal
E-1781	3	1	Camshaft Spacer Washer
E-1782	4	1	Camshaft Spacer Washer
E-3234	5	1	Camshaft Snap Ring
E-5482	6	1	Camshaft Wear Washer
E-580	7	1	Camshaft Spacer Washer

E-2125 For 15" and 16-1/4" Dia. Cam Brakes

APPLICATION & GENERAL INFORMATION

FOR EATON

Self-Contained Drive Axle Brakes

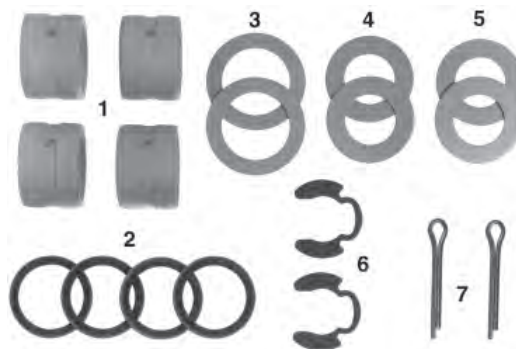

EUCLID NO.	ITEM	QTY	DESCRIPTION
E-536	1	4	Camshaft Bushing
E-1416	2	4	Camshaft Seal
E-580	3	2	Camshaft Spacer Washer
E-1781	4	2	Camshaft Spacer Washer
E-1782	5	2	Camshaft Spacer Washer
E-3234	6	2	Camshaft Snap Ring
E-1780	7	2	Cotter Pin

CAMSHAFT REPAIR KITS

E-2125-2 For 15" and 16-1/4" Dia. Cam Brakes

APPLICATION & GENERAL INFORMATION
FOR EATON

Self-Contained Drive Axle Brakes. Half kit includes exactly half of Kit E-2125 for one wheel end.

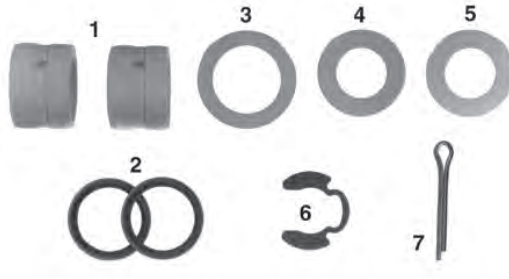

EUCLID NO.	ITEM	QTY	DESCRIPTION
E-536	1	2	Camshaft Bushing
E-1416	2	2	Camshaft Seal
E-580	3	1	Camshaft Spacer Washer
E-1781	4	1	Camshaft Spacer Washer
E-1782	5	1	Camshaft Spacer Washer
E-3234	6	1	Camshaft Snap Ring
E-1780	7	1	Cotter Pin

E-3468A For 15" and 16-1/4" Dia. Cam Brakes

APPLICATION & GENERAL INFORMATION
FOR MERITOR 15" and 16-1/4" DIAMETER "T" SERIES BRAKES WITH 1-1/2" DIAMETER CAMSHAFT

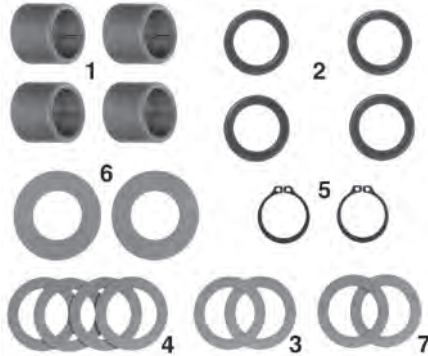

EUCLID NO.	ITEM	QTY	DESCRIPTION
E-5512	1	4	Camshaft Bushing
E-654	2	4	Camshaft Seal
E-581	3	2	Camshaft Spacer Washer
E-580	4	4	Camshaft Spacer Washer
E-4736	5	2	Camshaft Lock Ring
E-3473	6	2	Camshaft Spacer Washer
E-3472	7	2	Camshaft Spacer Washer

E-11904 For 15" and 16-1/2" Dia. Cam Brakes

APPLICATION & GENERAL INFORMATION
FOR MERITOR LX/MX 500 SERIES BRAKES

Services 1 brake. Use with stamped or cast spider.

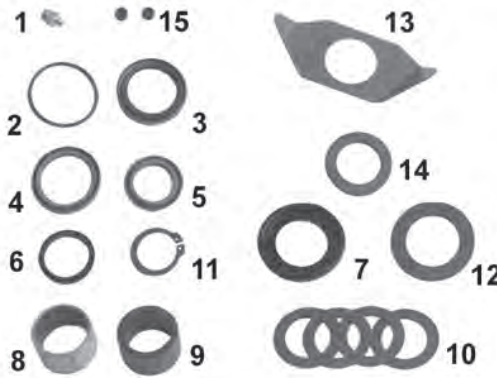

EUCLID NO.	ITEM	QTY	DESCRIPTION
NSS*	1	1	Lube Fitting
E-3859	2	1	Camshaft Seal
E-654	3	1	Camshaft Seal
NSS*	4	1	Grease Seal
NSS*	5	1	Seal
NSS*	6	1	Seal
NSS*	7	1	Seal
NSS*	8	1	Camshaft Bushing
NSS*	9	1	Camshaft Bushing
E-5095	10	4	Camshaft Spacer Washer
E-5093	11	1	Camshaft Lock Ring
NSS*	12	1	Flat Washer
NSS*	13	1	Special Washer
NSS*	14	1	Flat Washer
NSS*	15	2	Plug
NSS*	16	1	Grease (14 oz.) (Not Shown)

*Not Sold Separately

CAMSHAFT REPAIR KITS

E-3353A For 15" Dia. Cam Brakes

APPLICATION & GENERAL INFORMATION
 FOR WAGNER FRONT BRAKES
 15" x 3", 15" x 3-1/2", 15" x 4"



EUCLID NO.	ITEM	QTY	DESCRIPTION
E-2732	1	4	Bushing
E-2733	2	4	Camshaft Washer
E-2734	3	2	Snap Ring
E-3675	4	4	Seal

E-3354 For 15" Dia. Cam Brakes

APPLICATION & GENERAL INFORMATION
 FOR WAGNER DRIVE AXLE
 BRAKES 15" x 6", 15" x 7"

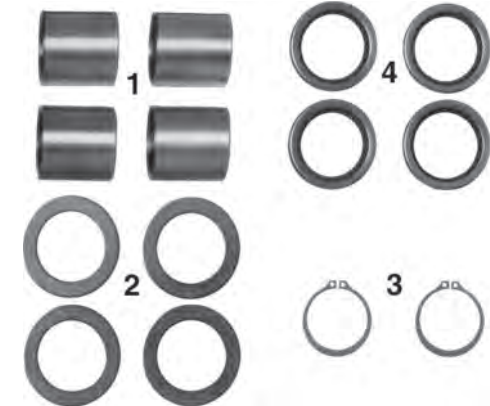

EUCLID NO.	ITEM	QTY	DESCRIPTION
E-2716	1	4	Bushing
E-2409	2	4	Camshaft Spacer Washer
E-4736	3	2	Camshaft Lock Ring
E-2717	4	4	Camshaft Seal

E-3446 For 15" Dia. Cam Brakes

APPLICATION & GENERAL INFORMATION
 FOR MERITOR 15" DIAMETER
 "T" SERIES BRAKES WITH
 1-1/4" DIAMETER CAMSHAFT

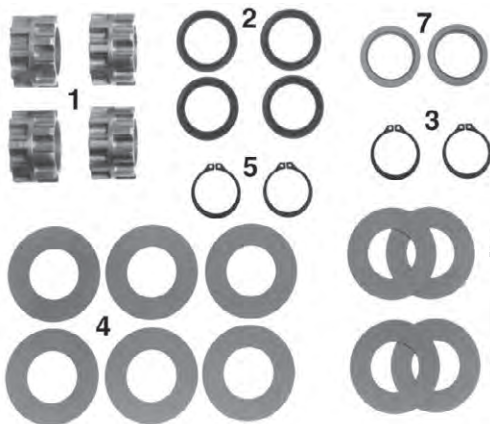

EUCLID NO.	ITEM	QTY	DESCRIPTION
E-3447	1	4	Camshaft Bushing
E-3469	2	4	Camshaft Seal
E-5093	3	2	Camshaft Lock Ring
E-3471	4	6	Camshaft Spacer Washer
E-801	5	2	Lock Ring
E-3475	6	2	Camshaft Spacer Washer
E-3474	7	2	Cam Spacer
E-3476	8	2	Camshaft Spacer Washer

CAMSHAFT REPAIR KITS

E-3446-2 For 15" Dia. Cam Brakes

APPLICATION & GENERAL INFORMATION

FOR MERITOR 15" DIAMETER "T" SERIES BRAKES WITH 1-1/4" DIAMETER CAMSHAFT

Half kit includes exactly half of Kit E-3446 for one wheel end.

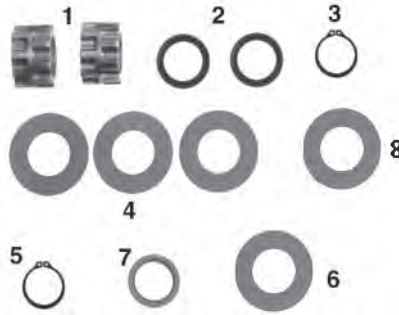

EUCLID NO.	ITEM	QTY	DESCRIPTION
E-3447	1	2	Camshaft Bushing
E-3469	2	2	Camshaft Seal
E-5093	3	1	Camshaft Lock Ring
E-3471	4	3	Camshaft Spacer Washer
E-801	5	1	Lock Ring
E-3475	6	1	Camshaft Spacer Washer
E-3474	7	1	Cam Spacer
E-3476	8	1	Camshaft Spacer Washer

E-3876 For 15" Dia. Cam Brakes

APPLICATION & GENERAL INFORMATION

FOR MERITOR STEERING AXLES WITH 15" "Q" SERIES BRAKES

For one complete axle.



EUCLID NO.	ITEM	QTY	DESCRIPTION
E-3877	1	4	Camshaft Bushing
E-3878	2	4	Camshaft Seal
E-9076	3	2	Camshaft Lock Ring
E-3476	4	4	Camshaft Spacer Washer

E-3876-2 For 15" Dia. Cam Brakes

APPLICATION & GENERAL INFORMATION

FOR MERITOR STEERING AXLES WITH 15" "Q" SERIES BRAKES

Half kit includes exactly half of Kit E-3876 for one wheel end.



EUCLID NO.	ITEM	QTY	DESCRIPTION
E-3877	1	2	Camshaft Bushing
E-3878	2	2	Camshaft Seal
E-9076	3	1	Camshaft Lock Ring
E-3476	4	2	Camshaft Spacer Washer

E-5140 For 15" Dia. Cam Brakes

APPLICATION & GENERAL INFORMATION

FOR EATON 15" x 4" SINGLE ANCHOR PIN FRONT AXLE BRAKE



EUCLID NO.	ITEM	QTY	DESCRIPTION
E-5127	1	4	Camshaft Bushing
E-5128	2	4	Camshaft Seal
E-5137	3	2	Camshaft Spacer Washer
E-5138	4	2	Camshaft Spacer Washer
E-3234	5	2	Camshaft Snap Ring

CAMSHAFT REPAIR KITS

E-5140-2 For 15" Dia. Cam Brakes

APPLICATION & GENERAL INFORMATION

FOR EATON 15" x 4" SINGLE ANCHOR PIN FRONT AXLE BRAKE

Half kit includes exactly half of Kit E-5140 for one wheel end.



EUCLID NO.	ITEM	QTY	DESCRIPTION
E-5127	1	2	Camshaft Bushing
E-5128	2	2	Camshaft Seal
E-5137	3	1	Camshaft Spacer Washer
E-5138	4	1	Camshaft Spacer Washer
E-3234	5	1	Camshaft Snap Ring

E-7235 For 15" Dia. Cam Brakes

APPLICATION & GENERAL INFORMATION

FOR BENDIX 15" x 4" STEER AXLE BRAKE

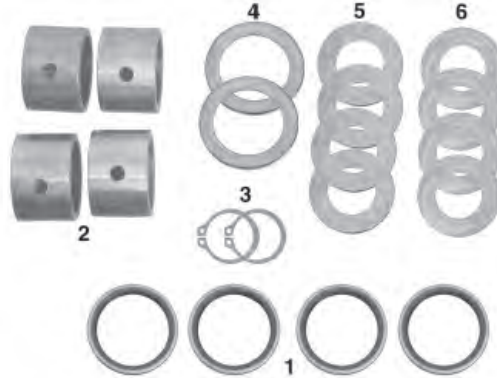

EUCLID NO.	ITEM	QTY	DESCRIPTION
E-1416A	1	4	Camshaft Seal
E-667	2	4	Bronze Camshaft Bushing
NSS*	3	2	Lock Ring
NSS*	4	2	Spacer
NSS*	5	4	Spacer
NSS*	6	4	Spacer

E-2086B For 16-1/2" and 18" Dia. Cam Brakes

APPLICATION & GENERAL INFORMATION

FOR MERITOR 16-1/2" and 18" DRIVE AXLE "P" SERIES BRAKES "UNIVERSAL KIT"

Contains E-526 Lock Ring for Camshafts with narrow groove. Contains E-4736 Lock Ring for Camshafts with wide groove. Contains E-3859 Rubber Camshaft Support Gasket. Contains New Style E-5512 Moly-impregnated Spider Bushing.

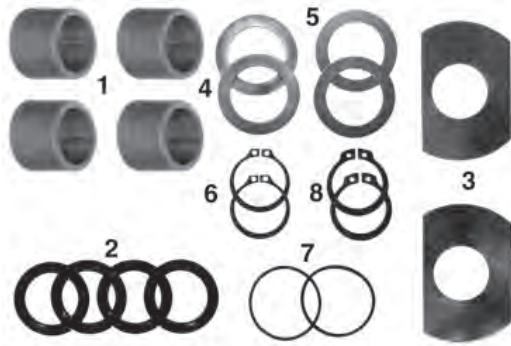

EUCLID NO.	ITEM	QTY	DESCRIPTION
E-5512	1	4	Camshaft Bushing
E-654	2	4	Camshaft Seal
E-656	3	2	Camshaft "D" Washer
E-580	4	2	Camshaft Spacer Washer
E-581	5	2	Camshaft Spacer Washer
E-526	6	2	Camshaft Lock Ring
E-3859	7	2	Camshaft Seal
E-4736	8	2	Camshaft Lock Ring

CAMSHAFT REPAIR KITS

E-2086B-2 For 16-1/2" and 18" Dia. Cam Brakes

APPLICATION & GENERAL INFORMATION

FOR MERITOR 16-1/2" and 18" DRIVE AXLE "P SERIES BRAKES "UNIVERSAL KIT"

Contains E-526 Lock Ring for Camshafts with narrow groove. Contains E-4736 Lock Ring for Camshafts with wide groove. Contains E-3859 Rubber Camshaft Support Gasket. Contains New Style E-5512 Moly-impregnated Spider Bushing. Contains half of Kit E-2086B.

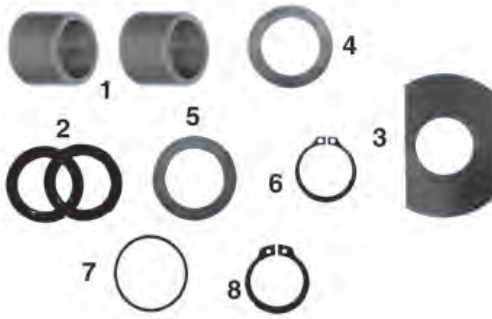

EUCLID NO.	ITEM	QTY	DESCRIPTION
E-5512	1	2	Camshaft Bushing
E-654	2	2	Camshaft Seal
E-656	3	1	Camshaft "D" Washer
E-580	4	1	Camshaft Spacer Washer
E-581	5	1	Camshaft Spacer Washer
E-526	6	1	Camshaft Lock Ring
E-3859	7	1	Camshaft Seal
E-4736	8	1	Camshaft Lock Ring

E-11450 For 16-1/2" Dia. Cam Brakes

APPLICATION & GENERAL INFORMATION

FOR HENDRICKSON Intraax® 16-1/2" BRAKE

2" bushing and seal O.D.

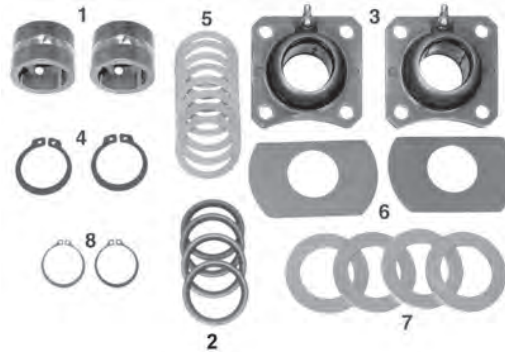

EUCLID NO.	ITEM	QTY	DESCRIPTION
E-11449	1	2	Bronze Camshaft Bushing
E-11451	2	4	Camshaft Seal
E-1318A	3	2	Camshaft Support Bracket
E-2720	4	2	Camshaft Lock Ring
E-564	5	8	Camshaft Spacer Washer
E-656	6	2	Camshaft "D" Washer
E-719	7	4	Camshaft Spacer Washer
E-801	8	2	Lock Ring

E-11450HD For 16-1/2" Dia. Cam Brakes

APPLICATION & GENERAL INFORMATION

FOR HENDRICKSON Intraax® 16-1/2" BRAKE

Replaces Hendrickson S-23974. Includes heavy-duty cam support bushings. 2" bushing and seal O.D.

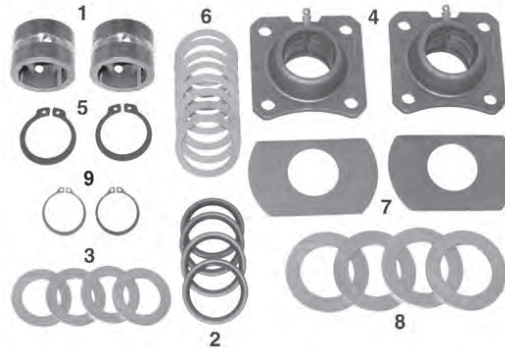

EUCLID NO.	ITEM	QTY	DESCRIPTION
E-11449	1	2	Bronze Camshaft Bushing
E-11451	2	4	Camshaft Seal
E-1113	3	4	Washer
E-1318AHD	4	2	Camshaft Support Bracket
E-2720	5	2	Camshaft Lock Ring
E-564	6	8	Camshaft Spacer Washer
E-656	7	2	Camshaft "D" Washer
E-719	8	4	Camshaft Spacer Washer
E-801	9	2	Lock Ring

E-11450HD-2 For 16-1/2" Dia. Cam Brakes

APPLICATION & GENERAL INFORMATION

FOR HENDRICKSON Intraax® 16-1/2" BRAKE

Half kit includes exactly half of Kit E-11450HD for one wheel end. 2" bushing and seal O.D.

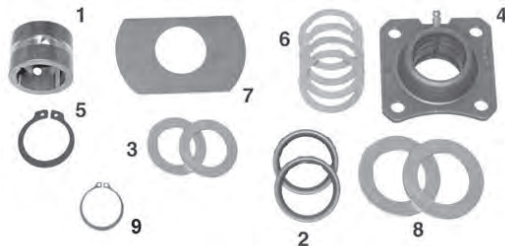

EUCLID NO.	ITEM	QTY	DESCRIPTION
E-11449	1	1	Bronze Camshaft Bushing
E-11451	2	2	Camshaft Seal
E-1113	3	2	Washer
E-1318AHD	4	1	Camshaft Support Bracket

CAMSHAFT REPAIR KITS

E-11819 For 16-1/2" Dia. Cam Brakes

APPLICATION & GENERAL INFORMATION

FOR EATON
16-1/2" BRAKE

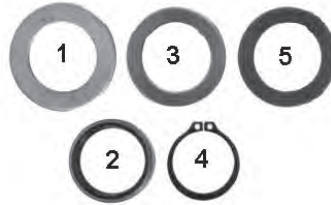

EUCLID NO.	ITEM	QTY	DESCRIPTION
E-1565	1	1	Washer
E-2405	2	1	Seal
E-5137	3	1	Washer
E-526	4	1	Ring
E-801	5	1	Washer

E-11897 For 16-1/2" Dia. Cam Brakes

APPLICATION & GENERAL INFORMATION
FOR HENDRICKSON Intraax®
16-1/2 IN. BRAKE

Replaces Hendrickson
S-26348. Includes cam tube.
Services one wheel end.

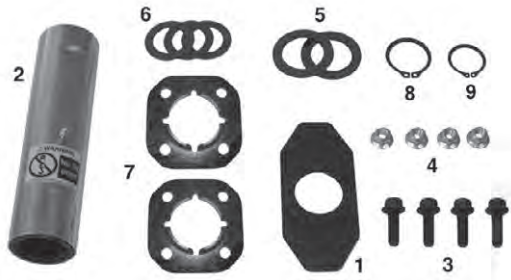

EUCLID NO.	ITEM	QTY	DESCRIPTION
NSS*	1	1	Outer Cam Washer
NSS*	2	1	Cam Tube Assembly
NSS*	3	4	Capscrew
NSS*	4	4	Flanged Head Lock Nut
NSS*	5	2	Journal Washer
NSS*	6	3	Spline Inner Washer
NSS*	7	2	Cam Tube Bracket
NSS*	8	1	Snap Ring
NSS*	9	1	Snap Ring

E-11977 For 16-1/2" Dia. Cam Brakes

APPLICATION & GENERAL INFORMATION
FOR HENDRICKSON Intraax®
16-1/2 IN. BRAKE

Services 2 brakes. Use with
fabricated spiders. Trailer axle
cam with bolt-on bushings.

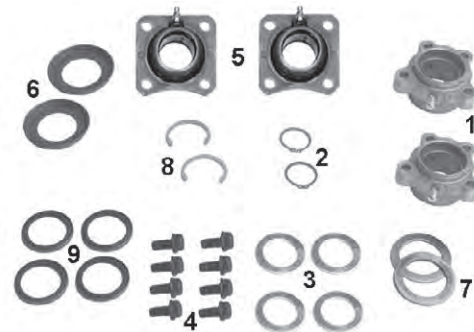

EUCLID NO.	ITEM	QTY	DESCRIPTION
E-11952	1	2	Retainer Bushing
E-801	2	2	Snap Ring
E-1113	3	4	Washer
E-1319A-1	4	8	Self-Tap Screw
E-1318A	5	2	Retainer
E-6077	6	2	Outer Washer
E-9072	7	2	Washer - Flat
E-9077	8	2	Snap Ring
E-2405	9	4	Seal

E-1357A For 16-1/2" Dia. Cam Brakes

APPLICATION & GENERAL INFORMATION
FOR EARLY MODEL MERITOR
"P" SERIES

For later Model Axles Using
E-1318B Bushing Assembly
Use Kit E-2679B Contains
Lock Rings for Camshafts with
narrow or wide grooves.

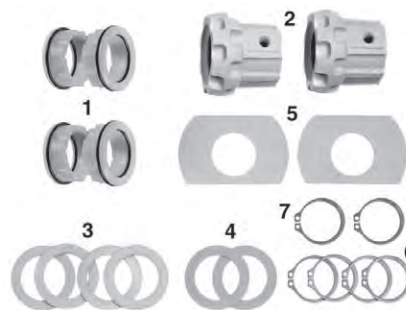

EUCLID NO.	ITEM	QTY	DESCRIPTION
E-943	1	2	Bushing Assy. (2 pc)
E-535	2	2	Camshaft Bushing
E-580	3	4	Camshaft Spacer Washer
E-581	4	2	Camshaft Spacer Washer
E-656	5	2	Camshaft "D" Washer
E-526	6	4	Camshaft Lock Ring
E-4736	7	2	Camshaft Lock Ring

*Not Sold Separately

CAMSHAFT REPAIR KITS

E-2087 For 16-1/2" Dia. Cam Brakes

APPLICATION & GENERAL INFORMATION

FOR ALL EARLY MODEL STANDARD FORGE and KERSHAW AXLES

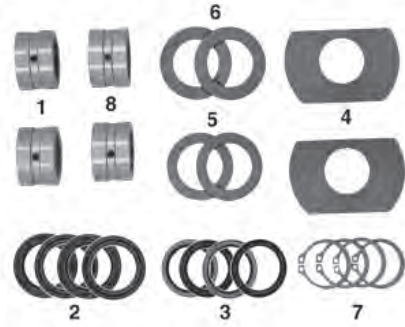

EUCLID NO.	ITEM	QTY	DESCRIPTION
E-536	1	2	Camshaft Bushing
E-654	2	4	Camshaft Seal
E-1416A	3	4	Camshaft Seal
E-656	4	2	Camshaft "D" Washer
E-719	5	2	Camshaft Spacer Washer
E-580	6	2	Camshaft Spacer Washer
E-526	7	4	Camshaft Lock Ring
E-759	8	2	Camshaft Spider Bushing

E-2087-2 For 16-1/2" Dia. Cam Brakes

APPLICATION & GENERAL INFORMATION

FOR ALL EARLY MODEL STANDARD FORGE and KERSHAW AXLES

Half kit includes exactly half of Kit E-2087 for one wheel end.



EUCLID NO.	ITEM	QTY	DESCRIPTION
E-536	1	1	Camshaft Bushing
E-654	2	2	Camshaft Seal
E-1416A	3	2	Camshaft Seal
E-656	4	1	Camshaft "D" Washer
E-719	5	1	Camshaft Spacer Washer
E-580	6	1	Camshaft Spacer Washer
E-526	7	2	Camshaft Lock Ring
E-759	8	1	Camshaft Spider Bushing

E-2088A For 16-1/2" Dia. Cam Brakes

APPLICATION & GENERAL INFORMATION

FOR LATE MODEL MERITOR "P" SERIES TRAILER BRAKES

With 1-1/2" Dia. Camshafts. Contains Lock Rings for Camshafts with narrow or wide grooves.

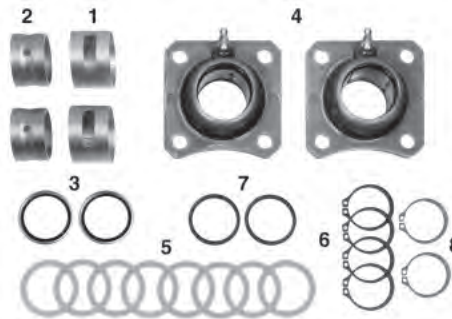

EUCLID NO.	ITEM	QTY	DESCRIPTION
E-2380	1	2	Camshaft Outer Bushing
E-1271	2	2	Camshaft Inner Bushing
E-1272	3	2	Camshaft Seal
E-1318A	4	2	Camshaft Support Bracket
E-564	5	8	Camshaft Spacer Washer
E-526	6	4	Camshaft Lock Ring
E-1416	7	2	Camshaft Seal
E-4736	8	2	Camshaft Lock Ring

E-2088AHD For 16-1/2" Dia. Cam Brakes

APPLICATION & GENERAL INFORMATION

FOR LATE MODEL MERITOR "P" SERIES TRAILER BRAKES

With 1-1/2" Dia. Camshafts. Contains Lock Rings for Camshafts with narrow or wide grooves. Contains E-1318AHD Heavy-Duty Support Assembly.

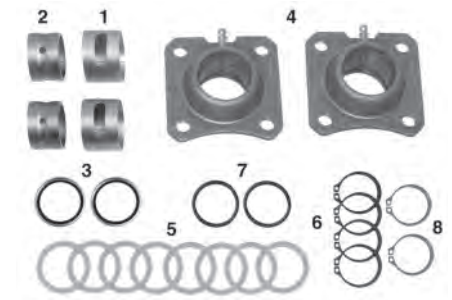

EUCLID NO.	ITEM	QTY	DESCRIPTION
E-2380	1	2	Camshaft Outer Bushing
E-1271	2	2	Camshaft Inner Bushing
E-1272	3	2	Camshaft Seal
E-1318AHD	4	2	Camshaft Support Bracket
E-564	5	8	Camshaft Spacer Washer
E-526	6	4	Camshaft Lock Ring
E-1416	7	2	Camshaft Seal
E-4736	8	2	Camshaft Lock Ring

CAMSHAFT REPAIR KITS

E-2088AHD-2

For 16-1/2" Dia. Cam Brakes

APPLICATION & GENERAL INFORMATION

FOR LATE MODEL MERITOR "P" SERIES TRAILER BRAKES

With 1-1/2" Dia. Camshafts. Contains Lock Rings for Camshafts with narrow or wide grooves. Contains E-1318AHD Heavy-Duty Support Assembly. Half kit includes exactly half of Kit E-2088AHD for one wheel end.

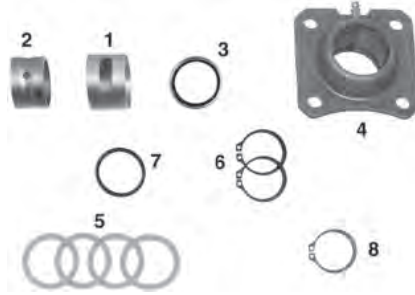

EUCLID NO.	ITEM	QTY	DESCRIPTION
E-2380	1	1	Camshaft Outer Bushing
E-1271	2	1	Camshaft Inner Bushing
E-1272	3	1	Camshaft Seal
E-1318AHD	4	1	Camshaft Support Bracket
E-564	5	4	Camshaft Spacer Washer
E-526	6	2	Camshaft Lock Ring
E-1416	7	1	Camshaft Seal
E-4736	8	1	Camshaft Lock Ring

NOTES

CAMSHAFT REPAIR KITS

E-2089 For 16-1/2" Dia. Cam Brakes

APPLICATION & GENERAL INFORMATION

FOR EARLY MODEL EATON (SHULER) 5" ROUND AXLE

(Bolt-On Spiders)

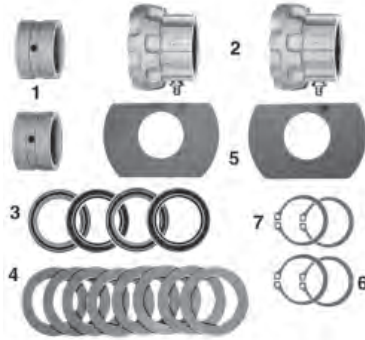

EUCLID NO.	ITEM	QTY	DESCRIPTION
E-536	1	2	Camshaft Bushing
E-1385	2	2	Camshaft Bushing
E-654	3	4	Camshaft Seal
E-580	4	8	Camshaft Spacer Washer
E-656	5	2	Camshaft "D" Washer
E-1569	6	2	Camshaft Lock Ring
E-526	7	2	Camshaft Lock Ring

E-2090 For 16-1/2" Dia. Cam Brakes

FOR LATE MODEL FRUEHAUF "PRO-PAR" AXLES WITH 16-1/2" BRAKES

Also used on 12-1/4" Brakes



EUCLID NO.	ITEM	QTY	DESCRIPTION
E-1567	1	4	Camshaft Spider Bushing
E-1577A	2	2	Camshaft Bushing
E-580	3	2	Camshaft Spacer Washer
E-1565	4	6	Camshaft Spacer Washer
E-1569	5	2	Camshaft Lock Ring
E-526	6	2	Camshaft Lock Ring
E-801	7	2	Lock Ring

E-2090-2 For 16-1/2" Dia. Cam Brakes

FOR LATE MODEL FRUEHAUF "PRO-PAR" AXLES WITH 16-1/2" BRAKES

Also used on 12-1/4" Brakes. Half kit includes exactly half of Kit E-2090 for one wheel end.



EUCLID NO.	ITEM	QTY	DESCRIPTION
E-1567	1	2	Camshaft Spider Bushing
E-1577A	2	1	Camshaft Bushing
E-580	3	1	Camshaft Spacer Washer
E-1565	4	3	Camshaft Spacer Washer
E-1569	5	1	Camshaft Lock Ring
E-526	6	1	Camshaft Lock Ring
E-801	7	1	Lock Ring

E-2122 For 16-1/2" Dia. Cam Brakes

FOR EARLY MODEL FRUEHAUF "PRO-PAR" AXLES



EUCLID NO.	ITEM	QTY	DESCRIPTION
E-1567	1	4	Camshaft Spider Bushing
E-1571	2	2	Camshaft Bushing
E-580	3	2	Camshaft Spacer Washer
E-1565	4	6	Camshaft Spacer Washer
E-1569	5	2	Camshaft Lock Ring
E-526	6	2	Camshaft Lock Ring
E-801	7	2	Lock Ring

CAMSHAFT REPAIR KITS

E-2122-2 For 16-1/2" Dia. Cam Brakes

APPLICATION & GENERAL INFORMATION
 FOR EARLY MODEL
 FRUEHAUF "PRO-PAR" AXLES

Half kit includes exactly half of
 Kit E-2122 for one wheel end.



EUCLID NO.	ITEM	QTY	DESCRIPTION
E-1567	1	2	Camshaft Spider Bushing
E-1571	2	1	Camshaft Bushing
E-580	3	1	Camshaft Spacer Washer
E-1565	4	3	Camshaft Spacer Washer
E-1569	5	1	Camshaft Lock Ring
E-526	6	1	Camshaft Lock Ring
E-801	7	1	Lock Ring

E-2123 For 16-1/2" Dia. Cam Brakes

APPLICATION & GENERAL INFORMATION
 FOR EATON (SHULER) 22L
 and 23L 5" SQUARE AXLE

Also Late Model "C" Series 5"
 Round Axles

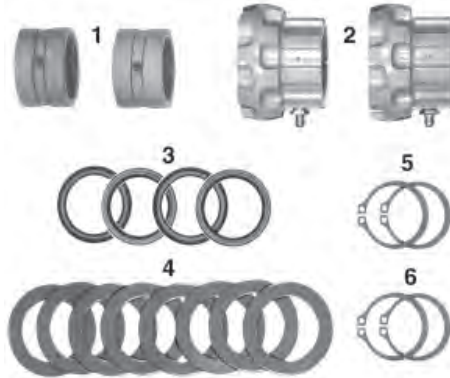

EUCLID NO.	ITEM	QTY	DESCRIPTION
E-536	1	2	Camshaft Bushing
E-1385	2	2	Camshaft Bushing
E-1416	3	4	Camshaft Seal
E-580	4	8	Camshaft Spacer Washer
E-1569	5	2	Camshaft Lock Ring
E-526	6	2	Camshaft Lock Ring

E-2287 For 16-1/2" Dia. Cam Brakes

APPLICATION & GENERAL INFORMATION
 FOR SPICER and STANDARD
 FORGE LATE MODEL A-17S,
 A-19S, A22-S AXLES

With Weld-on Spiders

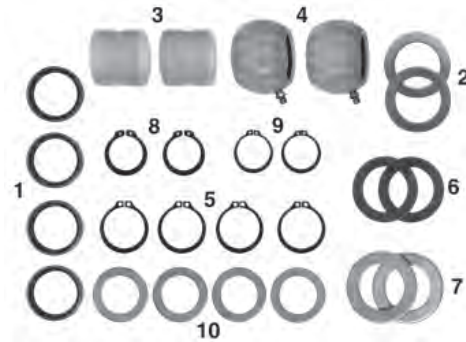

EUCLID NO.	ITEM	QTY	DESCRIPTION
E-1416A	1	4	Camshaft Seal
E-719	2	2	Camshaft Spacer Washer
E-759	3	2	Camshaft Spider Bushing
E-2102	4	2	Camshaft Bushing
E-526	5	4	Camshaft Lock Ring
E-2409	6	2	Camshaft Spacer Washer
E-580	7	2	Camshaft Spacer Washer
E-5093	8	2	Camshaft Lock Ring
E-801	9	2	Lock Ring
E-1113	10	4	Washer

E-2287-2 For 16-1/2" Dia. Cam Brakes

APPLICATION & GENERAL INFORMATION
 FOR SPICER and STANDARD
 FORGE LATE MODEL A-17S,
 A-19S, A22-S AXLES

With Weld-on Spiders. Half
 kit includes exactly half of Kit
 E-2287 for one wheel end.

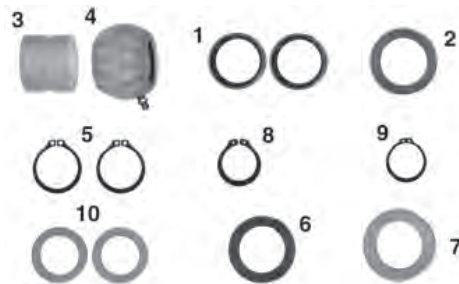

EUCLID NO.	ITEM	QTY	DESCRIPTION
E-1416A	1	2	Camshaft Seal
E-719	2	1	Camshaft Spacer Washer
E-759	3	1	Camshaft Spider Bushing
E-2102	4	1	Camshaft Bushing
E-526	5	2	Camshaft Lock Ring
E-2409	6	1	Camshaft Spacer Washer
E-580	7	1	Camshaft Spacer Washer
E-5093	8	1	Camshaft Lock Ring
E-801	9	1	Lock Ring
E-1113	10	2	Washer

CAMSHAFT REPAIR KITS

E-2363 For 16-1/2" Dia. Cam Brakes

APPLICATION & GENERAL INFORMATION

FOR LATE MODEL MERITOR "P" SERIES TRAILER BRAKES

With 1-1/2" Dia. Camshafts.
Contains Lock Rings for Camshafts with narrow or wide grooves.

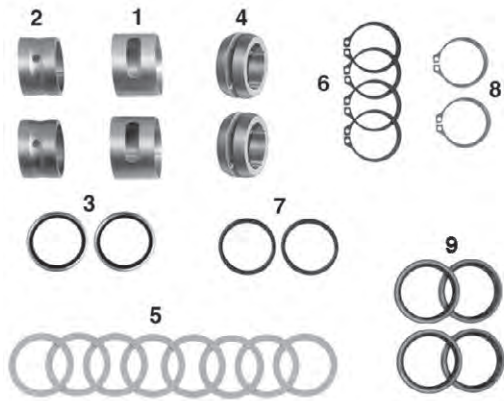

EUCLID NO.	ITEM	QTY	DESCRIPTION
E-2380	1	2	Camshaft Outer Bushing
E-1271	2	2	Camshaft Inner Bushing
E-1272	3	2	Camshaft Seal
E-2361	4	2	Camshaft Bushing
E-564	5	8	Camshaft Spacer Washer
E-526	6	4	Camshaft Lock Ring
E-1416	7	2	Camshaft Seal
E-4736	8	2	Camshaft Lock Ring
E-1314	9	4	Camshaft Seal

E-2382 For 16-1/2" Dia. Cam Brakes

APPLICATION & GENERAL INFORMATION

FOR LATE MODEL MERITOR 4000-6000 SERIES TRAILER AXLES

With 1-5/8" Dia. Camshafts.
Also used for 12-1/4" "Q" Brakes.



EUCLID NO.	ITEM	QTY	DESCRIPTION
E-564	1	2	Camshaft Spacer Washer
E-2361	2	2	Camshaft Bushing
E-801	3	2	Lock Ring
E-2405	4	2	Camshaft Seal
E-2406	5	2	Camshaft Seal
E-2407	6	2	Camshaft Outer Bushing
E-2408	7	2	Camshaft Inner Bushing
E-1569	8	2	Camshaft Lock Ring
E-1113	9	2	Washer
E-2411A	10	4	Camshaft Spacer Washer
E-5093	11	2	Camshaft Lock Ring
E-1314	12	4	Camshaft Seal

E-2679A For 16-1/2" Dia. Cam Brakes

APPLICATION & GENERAL INFORMATION

FOR MERITOR "P" SERIES TRAILER BRAKES

Use One-Piece Green Spider Bushing in Place of E-943 Two-Piece Split Bushing.

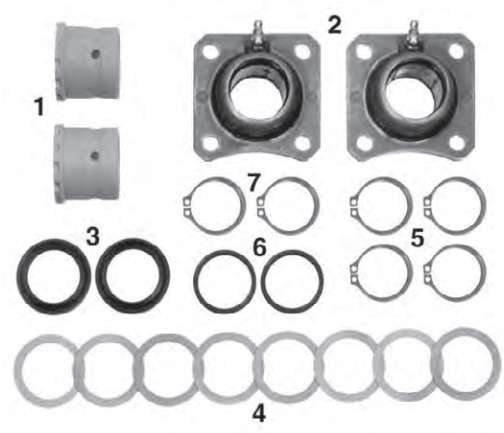

EUCLID NO.	ITEM	QTY	DESCRIPTION
E-2551	1	2	Camshaft Bushing
E-1318A	2	2	Camshaft Support Bracket
E-1272	3	2	Camshaft Seal
E-564	4	8	Camshaft Spacer Washer
E-526	5	4	Camshaft Lock Ring
E-654	6	2	Camshaft Seal
E-4736	7	2	Camshaft Lock Ring

CAMSHAFT REPAIR KITS

E-2679AHD For 16-1/2" Dia. Cam Brakes

APPLICATION & GENERAL INFORMATION
 FOR MERITOR "P" SERIES TRAILER BRAKES

Use One-Piece Green Spider Bushing in Place of E-943 Two-Piece Split Bushing. Contains Lock Rings for Camshafts with narrow or wide grooves. Contains E-1318AHD Heavy-Duty Support Assembly.

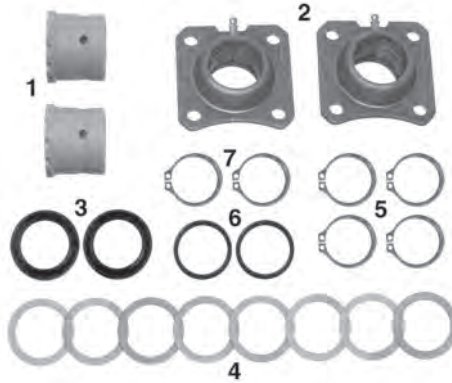

EUCLID NO.	ITEM	QTY	DESCRIPTION
E-2551	1	2	Camshaft Bushing
E-1318AHD	2	2	Camshaft Support Bracket
E-1272	3	2	Camshaft Seal
E-564	4	8	Camshaft Spacer Washer
E-526	5	4	Camshaft Lock Ring
E-654	6	2	Camshaft Seal
E-4736	7	2	Camshaft Lock Ring

E-2680 For 16-1/2" Dia. Cam Brakes

APPLICATION & GENERAL INFORMATION
 FOR SPICER (DANA) AXLE

With Spherical Cam Bushings



EUCLID NO.	ITEM	QTY	DESCRIPTION
E-807	1	2	Bronze Camshaft Bushing
E-1416	2	4	Camshaft Seal
E-656	3	2	Camshaft "D" Washer
E-719	4	2	Camshaft Spacer Washer
E-580	5	2	Camshaft Spacer Washer
E-526	6	4	Camshaft Lock Ring
E-2517	7	2	Camshaft Bushing
E-1314	8	4	Camshaft Seal
E-5093	9	2	Camshaft Lock Ring

E-2680-2 For 16-1/2" Dia. Cam Brakes

APPLICATION & GENERAL INFORMATION
 FOR SPICER (DANA) AXLE

With Spherical Cam Bushings. Half kit includes exactly half of Kit E-2680 for one wheel end.

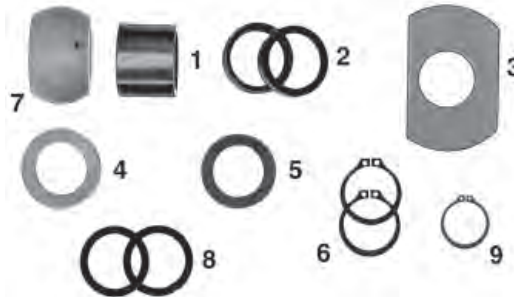

EUCLID NO.	ITEM	QTY	DESCRIPTION
E-807	1	1	Bronze Camshaft Bushing
E-1416	2	2	Camshaft Seal
E-656	3	1	Camshaft "D" Washer
E-719	4	1	Camshaft Spacer Washer
E-580	5	1	Camshaft Spacer Washer
E-526	6	2	Camshaft Lock Ring
E-2517	7	1	Camshaft Bushing
E-1314	8	2	Camshaft Seal
E-5093	9	1	Camshaft Lock Ring

E-2696A For 16-1/2" Dia. Cam Brakes

APPLICATION & GENERAL INFORMATION
 FOR LATE MODEL EATON TRAILER AXLE

With "501" Series Brakes and "ES" Brakes with Long Life Cam Support Bushings

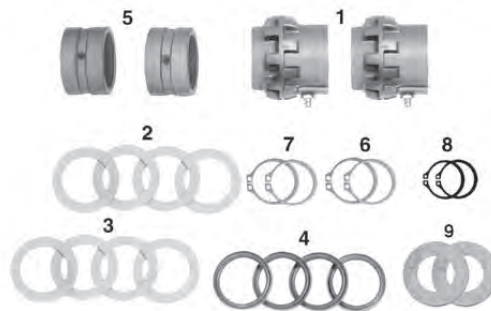

EUCLID NO.	ITEM	QTY	DESCRIPTION
E-2695	1	2	Camshaft Bushing
E-1565	2	4	Camshaft Spacer Washer
E-580	3	4	Camshaft Spacer Washer
E-2405	4	4	Camshaft Seal
E-2690A	5	2	Camshaft Bushing
E-1569	6	2	Camshaft Lock Ring
E-526	7	2	Camshaft Lock Ring
E-801	8	2	Lock Ring
E-5137	9	2	Camshaft Spacer Washer

CAMSHAFT REPAIR KITS

E-2696A-2 For 16-1/2" Dia. Cam Brakes

APPLICATION & GENERAL INFORMATION

FOR LATE MODEL EATON TRAILER AXLE

With "501" Series Brakes and "ES" Brakes with Long Life Cam Support Bushings. Half kit includes exactly half of Kit E-2696A for one wheel end.

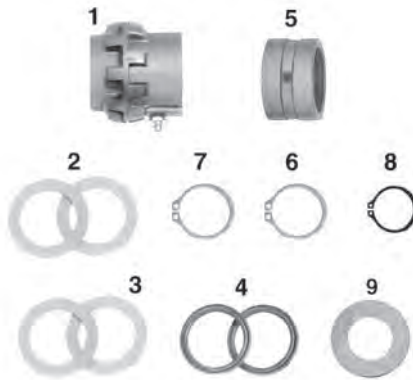

EUCLID NO.	ITEM	QTY	DESCRIPTION
E-2695	1	1	Camshaft Bushing
E-1565	2	2	Camshaft Spacer Washer
E-580	3	2	Camshaft Spacer Washer
E-2405	4	2	Camshaft Seal
E-2690A	5	1	Camshaft Bushing
E-1569	6	1	Camshaft Lock Ring
E-526	7	1	Camshaft Lock Ring
E-801	8	1	Lock Ring
E-5137	9	1	Camshaft Spacer Washer

E-3520A For 16-1/2" Dia. Cam Brakes

APPLICATION & GENERAL INFORMATION

FOR LATE MODEL MERITOR 4000-6000 SERIES TRAILER AXLES

With 1-5/8" Dia. Camshafts. Also used for 12-1/4" "Q" Brakes. Contains Lock Rings for Camshafts with narrow or wide grooves.



EUCLID NO.	ITEM	QTY	DESCRIPTION
E-564	1	2	Camshaft Spacer Washer
E-1318A	2	2	Camshaft Support Bracket
E-801	3	2	Lock Ring
E-2405	4	2	Camshaft Seal
E-2406	5	2	Camshaft Seal
E-2407	6	2	Camshaft Outer Bushing
E-2408	7	2	Camshaft Inner Bushing
E-1569	8	2	Camshaft Lock Ring
E-1113	9	2	Washer
E-2411A	10	4	Camshaft Spacer Washer
E-5093	11	2	Camshaft Lock Ring

E-3520A-2 For 16-1/2" Dia. Cam Brakes

APPLICATION & GENERAL INFORMATION

FOR LATE MODEL MERITOR 4000-6000 SERIES TRAILER AXLES

With 1-5/8" Dia. Camshafts. Also used for 12-1/4" "Q" Brakes. Contains Lock Rings for Camshafts with narrow or wide grooves. Half kit includes exactly half of Kit E-3520A for one wheel end.

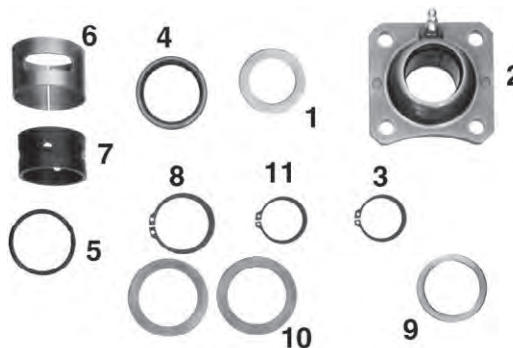

EUCLID NO.	ITEM	QTY	DESCRIPTION
E-564	1	1	Camshaft Spacer Washer
E-1318A	2	1	Camshaft Support Bracket
E-801	3	1	Lock Ring
E-2405	4	1	Camshaft Seal
E-2406	5	1	Camshaft Seal
E-2407	6	1	Camshaft Outer Bushing
E-2408	7	1	Camshaft Inner Bushing
E-1569	8	1	Camshaft Lock Ring
E-1113	9	1	Washer
E-2411A	10	2	Camshaft Spacer Washer
E-5093	11	1	Camshaft Lock Ring

CAMSHAFT REPAIR KITS

E-3520AHD For 16-1/2" Dia. Cam Brakes

APPLICATION & GENERAL INFORMATION

FOR LATE MODEL MERITOR 4000-6000 SERIES TRAILER AXLES

With 1-5/8" Dia. Camshafts. Also used for 12-1/4" "Q" Brakes. Contains Lock Rings for Camshafts with narrow or wide grooves. Same as E-3520A except contains E-1318AHD Heavy-Duty Support Assembly.



EUCLID NO.	ITEM	QTY	DESCRIPTION
E-564	1	2	Camshaft Spacer Washer
E-1318AHD	2	2	Camshaft Support Bracket
E-801	3	2	Lock Ring
E-2405	4	2	Camshaft Seal
E-2406	5	2	Camshaft Seal
E-2407	6	2	Camshaft Outer Bushing
E-2408	7	2	Camshaft Inner Bushing
E-1569	8	2	Camshaft Lock Ring
E-1113	9	2	Washer
E-2411A	10	4	Camshaft Spacer Washer
E-5093	11	2	Camshaft Lock Ring

E-3520AHD-2 For 16-1/2" Dia. Cam Brakes

APPLICATION & GENERAL INFORMATION

FOR LATE MODEL MERITOR 4000-6000 SERIES TRAILER AXLES

With 1-5/8" Dia. Camshafts. Also used for 12-1/4" "Q" Brakes. Contains Lock Rings for Camshafts w/ narrow or wide grooves. Same as E-3520A-2 exc. contains E-1318AHD Heavy-Duty Support Assy. Half kit incl exactly half of Kit E-3520A for one wheel end



EUCLID NO.	ITEM	QTY	DESCRIPTION
E-564	1	1	Camshaft Spacer Washer
E-1318AHD	2	1	Camshaft Support Bracket
E-801	3	1	Lock Ring
E-2405	4	1	Camshaft Seal
E-2406	5	1	Camshaft Seal
E-2407	6	1	Camshaft Outer Bushing
E-2408	7	1	Camshaft Inner Bushing
E-1569	8	1	Camshaft Lock Ring
E-1113	9	1	Washer
E-2411A	10	2	Camshaft Spacer Washer
E-5093	11	1	Camshaft Lock Ring

E-3989AHD For 16-1/2" Dia. Cam Brakes

APPLICATION & GENERAL INFORMATION

FOR LATE MODEL MERITOR 4000-6000 SERIES TRAILER AXLES

With 1-5/8" Dia. Camshafts. Alternate Kit for E-3520AHD. Contains Lock Rings for Camshafts with narrow or wide grooves. Contains E-1318AHD Heavy-Duty Support Assembly.

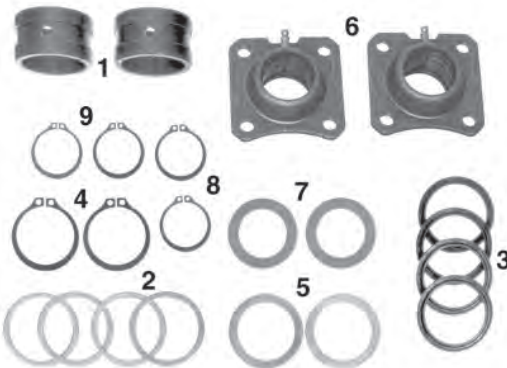

EUCLID NO.	ITEM	QTY	DESCRIPTION
E-2690A	1	2	Camshaft Bushing
E-2411A	2	4	Camshaft Spacer Washer
E-3991	3	4	Camshaft Seal
E-1569	4	2	Camshaft Lock Ring
E-564	5	2	Camshaft Spacer Washer
E-1318AHD	6	2	Camshaft Support Bracket
E-1113	7	2	Washer
E-801	8	2	Lock Ring
E-5093	9	2	Camshaft Lock Ring

CAMSHAFT REPAIR KITS

E-3989AHD-2

For 16-1/2" Dia. Cam Brakes

APPLICATION & GENERAL INFORMATION

FOR LATE MODEL MERITOR 4000-6000 SERIES TRAILER AXLES

With 1-5/8" Dia. Camshafts. Alternate Kit for E-3520AHD-2. Contains Lock Rings for Camshafts with narrow or wide grooves. Contains E-1318AHD Heavy- Duty Support Assy. Half kit contains exactly half of Kit E-3989AHD for one wheel end.



EUCLID NO.	ITEM	QTY	DESCRIPTION
E-2690A	1	1	Camshaft Bushing
E-2411A	2	2	Camshaft Spacer Washer
E-3991	3	2	Camshaft Seal
E-1569	4	1	Camshaft Lock Ring
E-564	5	1	Camshaft Spacer Washer
E-1318AHD	6	1	Camshaft Support Bracket
E-1113	7	1	Washer
E-801	8	1	Lock Ring
E-5093	9	1	Camshaft Lock Ring

E-5094A

For 16-1/2" Dia. Cam Brakes

APPLICATION & GENERAL INFORMATION

FOR MACK WITH MERITOR "Q" BRAKE WITH 50,000 LB. REAR AXLE

Contains New Style E-5512 Moly-impregnated Spider Bushing.

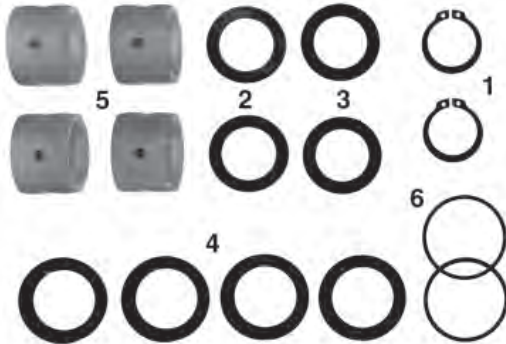

EUCLID NO.	ITEM	QTY	DESCRIPTION
E-5093	1	2	Camshaft Lock Ring
E-1113	2	2	Washer
E-5095	3	2	Camshaft Spacer Washer
E-654	4	4	Camshaft Seal
E-5512	5	4	Camshaft Bushing
E-3859	6	2	Camshaft Seal

CAMSHAFT REPAIR KITS

E-5513 For 16-1/2" Dia. Cam Brakes

APPLICATION & GENERAL INFORMATION
 FOR MERITOR DRIVE AXLES WITH 16-1/2" "Q" or "Q PLUS" BRAKES



EUCLID NO.	ITEM	QTY	DESCRIPTION
E-5512	1	4	Camshaft Bushing
E-654	2	4	Camshaft Seal

Services two camshaft tube enclosures

E-6078 For 16-1/2" Dia. Cam Brakes

APPLICATION & GENERAL INFORMATION
 FOR MERITOR TRAILER AXLES WITH FABRICATED SPIDERS



EUCLID NO.	ITEM	QTY	DESCRIPTION
E-6076	1	1	Camshaft Bushing
E-6077	2	1	Camshaft Washer
E-2405 Not Sold Separately	3	2	Camshaft Seal
E-9077	4	4	Screw
E-9072	5	1	Camshaft Lock Ring
E-9072	6	1	Camshaft Spacer Washer

Services one spider

E-9053 For 16-1/2" Dia. Cam Brakes

APPLICATION & GENERAL INFORMATION
 FOR EATON "ES" SEVERE SERVICE DRIVE AXLE BRAKES



EUCLID NO.	ITEM	QTY	DESCRIPTION
E-536	1	2	Camshaft Bushing
E-667	2	2	Bronze Camshaft Bushing
E-1416	3	4	Camshaft Seal
E-580	4	4	Camshaft Spacer Washer
E-1781	5	2	Camshaft Spacer Washer
E-1782	6	2	Camshaft Spacer Washer
E-3234	7	2	Camshaft Snap Ring

CAMSHAFT REPAIR KITS

E-9078 For 16-1/2" Dia. Cam Brakes

APPLICATION & GENERAL INFORMATION

FOR MERITOR "Q" AND "Q PLUS" TRAILER AXLE BRAKES WITH PRESS-IN POWDERED METAL SPIDER BUSHING

Contains enough parts to service Forged or Fabricated Brake Spiders and Camshafts with either 1-25/32" or 2-5/64" Camshaft Journal.

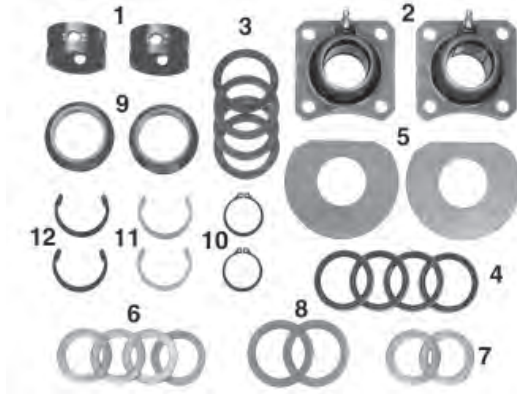

EUCLID NO.	ITEM	QTY	DESCRIPTION
E-6080	1	2	Camshaft Bushing
E-1318A	2	2	Camshaft Support Bracket
E-2405	3	4	Camshaft Seal
E-2411A	4	4	Camshaft Spacer Washer
E-9073	5	2	Camshaft Head Washer
E-1113	6	4	Washer
E-564	7	2	Camshaft Spacer Washer
E-9074	8	2	Camshaft Spacer Washer
E-9075	9	2	Camshaft Spacer Washer
E-5093	10	2	Camshaft Lock Ring
E-1569	11	2	Camshaft Lock Ring
E-9077	12	2	Camshaft Lock Ring

E-9078HD For 16-1/2" Dia. Cam Brakes

APPLICATION & GENERAL INFORMATION

FOR MERITOR "Q" AND "Q PLUS" TRAILER AXLE BRAKES WITH PRESS-IN POWDERED METAL SPIDER BUSHING

Contains enough parts to service Forged or Fabricated Brake Spiders and Camshafts with either 1-25/32" or 2-5/64" Camshaft Journal. Contains E-1318AHD Heavy-Duty Support Assembly.

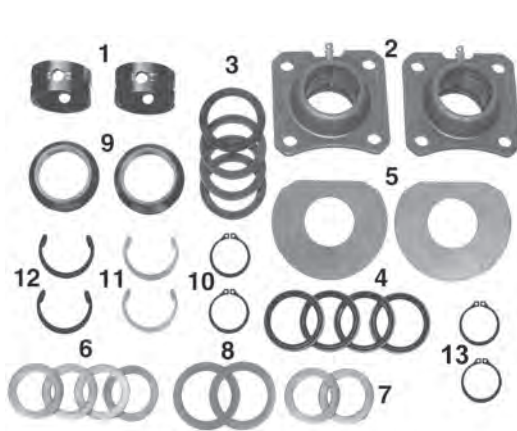

EUCLID NO.	ITEM	QTY	DESCRIPTION
E-6080	1	2	Camshaft Bushing
E-1318AHD	2	2	Camshaft Support Bracket
E-2405	3	4	Camshaft Seal
E-2411A	4	4	Camshaft Spacer Washer
E-9073	5	2	Camshaft Head Washer
E-1113	6	4	Washer
E-564	7	2	Camshaft Spacer Washer
E-9074	8	2	Camshaft Spacer Washer
E-9075	9	2	Camshaft Spacer Washer
E-5093	10	2	Camshaft Lock Ring
E-1569	11	2	Camshaft Lock Ring
E-9077	12	2	Camshaft Lock Ring
E-801	13	2	Lock Ring

E-9078HD-2 For 16-1/2" Dia. Cam Brakes

APPLICATION & GENERAL INFORMATION

FOR MERITOR "Q" AND "Q PLUS" TRAILER AXLE BRAKES WITH PRESS-IN POWDERED METAL SPIDER BUSHING

Contains enough parts to service Forged or Fabricated Brake Spiders and Camshafts with either 1-25/32" or 2-5/64" Camshaft Journal. Contains E-1318AHD Heavy-Duty Support Assy. Half kit includes exactly half of Kit E-9078HD for one wheel end.

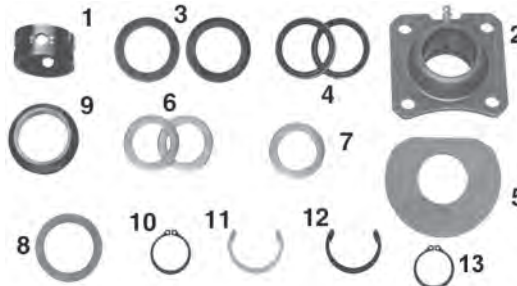

EUCLID NO.	ITEM	QTY	DESCRIPTION
E-6080	1	1	Camshaft Bushing
E-1318AHD	2	1	Camshaft Support Bracket
E-2405	3	2	Camshaft Seal
E-2411A	4	2	Camshaft Spacer Washer
E-9073	5	1	Camshaft Head Washer
E-1113	6	2	Washer
E-564	7	1	Camshaft Spacer Washer
E-9074	8	1	Camshaft Spacer Washer
E-9075	9	1	Camshaft Spacer Washer
E-5093	10	1	Camshaft Lock Ring
E-1569	11	1	Camshaft Lock Ring
E-9077	12	1	Camshaft Lock Ring
E-801	13	1	Lock Ring

CAMSHAFT REPAIR KITS

E-9079 For 16-1/2" Dia. Cam Brakes

APPLICATION & GENERAL INFORMATION
 FOR MERITOR "Q" AND "Q PLUS" TRAILER AXLE BRAKES WITH BOLT-ON POWDERED METAL SPIDER BUSHING ON FABRICATED SPIDERS



EUCLID NO.	ITEM	QTY	DESCRIPTION
E-6076	1	2	Camshaft Bushing
E-1318A	2	2	Camshaft Support Bracket
E-5093	3	2	Camshaft Lock Ring
E-1113	4	2	Washer
E-564	5	2	Camshaft Spacer Washer
E-6077	6	2	Camshaft Washer
E-2405	7	4	Camshaft Seal
E-9072	8	2	Camshaft Spacer Washer
E-9077	9	2	Camshaft Lock Ring
NSS*	10	8	Screw
E-801	11	2	Lock Ring

E-9079HD For 16-1/2" Dia. Cam Brakes

APPLICATION & GENERAL INFORMATION
 FOR MERITOR "Q" AND "Q PLUS" TRAILER AXLE BRAKES WITH BOLT-ON POWDERED METAL SPIDER BUSHING ON FABRICATED SPIDERS

Contains E-1318AHD Heavy-Duty Support Assembly.

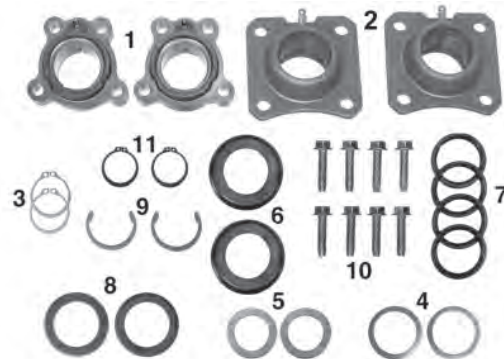

EUCLID NO.	ITEM	QTY	DESCRIPTION
E-6076	1	2	Camshaft Bushing
E-1318AHD	2	2	Camshaft Support Bracket
E-5093	3	2	Camshaft Lock Ring
E-1113	4	2	Washer
E-564	5	2	Camshaft Spacer Washer
E-6077	6	2	Camshaft Washer
E-2405	7	4	Camshaft Seal
E-9072	8	2	Camshaft Spacer Washer
E-9077	9	2	Camshaft Lock Ring
NSS*	10	8	Screw
E-801	11	2	Lock Ring

E-9079HD-2 For 16-1/2" Dia. Cam Brakes

APPLICATION & GENERAL INFORMATION
 FOR MERITOR "Q" AND "Q PLUS" TRAILER AXLE BRAKES WITH BOLT-ON POWDERED METAL SPIDER BUSHING ON FABRICATED SPIDERS

Contains E-1318AHD Heavy-Duty Support Assembly. Half kit includes exactly half of Kit E-9079HD for one wheel end.

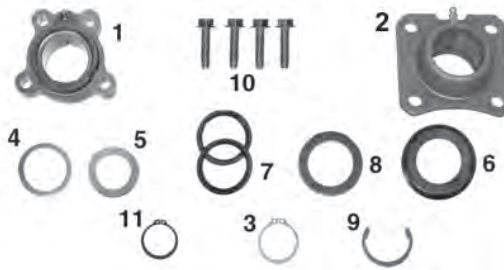

EUCLID NO.	ITEM	QTY	DESCRIPTION
E-6076	1	1	Camshaft Bushing
E-1318AHD	2	1	Camshaft Support Bracket
E-5093	3	1	Camshaft Lock Ring
E-1113	4	1	Washer
E-564	5	1	Camshaft Spacer Washer
E-6077	6	1	Camshaft Washer
E-2405	7	2	Camshaft Seal
E-9072	8	1	Camshaft Spacer Washer
E-9077	9	1	Camshaft Lock Ring
NSS*	10	4	Screw
E-801	11	1	Lock Ring

CAMSHAFT REPAIR KITS

E-9080 For 16-1/2" Dia. Cam Brakes

APPLICATION & GENERAL INFORMATION
FOR MERITOR "P" and "Q" DRIVE AXLE BRAKES WITH 2-1/2" SPIDER OFFSET

Contains New Style E-5512 Moly-impregnated Spider Bushing. Contains Lock Rings for Camshafts with narrow or wide grooves. Commonly found on Mack Trucks.

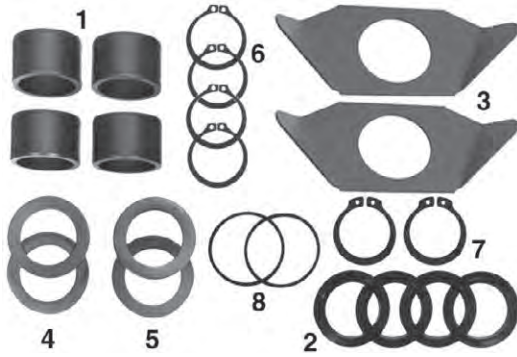

EUCLID NO.	ITEM	QTY	DESCRIPTION
E-5512	1	4	Camshaft Bushing
E-654	2	4	Camshaft Seal
E-9071	3	2	Camshaft Head Washer
E-580	4	2	Camshaft Spacer Washer
E-581	5	2	Camshaft Spacer Washer
E-526	6	4	Camshaft Lock Ring
E-4736	7	2	Camshaft Lock Ring
E-3859	8	2	Camshaft Seal

E-9790A-2 For 16-1/2" Dia. Cam Brakes

APPLICATION & GENERAL INFORMATION
FOR SPICER (DANA) 16-1/2" BRAKE WITH 1-5/8" CAM JOURNAL

Half kit includes exactly half of Kit E-9790A for one wheel end.

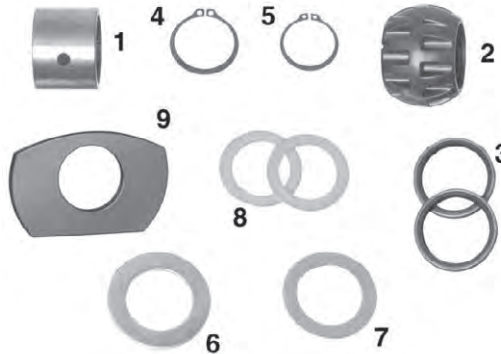

EUCLID NO.	ITEM	QTY	DESCRIPTION
E-9789	1	1	Camshaft Bushing
E-9792A	2	1	Camshaft Bushing
E-2405	3	2	Camshaft Seal
E-1569	4	1	Camshaft Lock Ring
E-801	5	1	Lock Ring
E-10800	6	1	Cam Washer
E-580	7	1	Camshaft Spacer Washer
E-1113	8	2	Washer
E-10801	9	1	Cam Washer

E-9791 For 16-1/2" Dia. Cam Brakes

APPLICATION & GENERAL INFORMATION
FOR HENDRICKSON Intraax® 16-1/2" BRAKE

1-7/8" bushing and seal O.D.

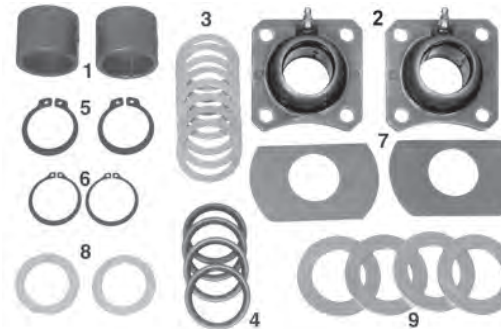

EUCLID NO.	ITEM	QTY	DESCRIPTION
E-807	1	2	Bronze Camshaft Bushing
E-1318A	2	2	Camshaft Support Bracket
E-564	3	8	Camshaft Spacer Washer
E-1416	4	4	Camshaft Seal
E-801	5	2	Lock Ring
E-2720	6	2	Camshaft Lock Ring
E-656	7	2	Camshaft "D" Washer
E-1113	8	2	Washer
E-719	9	4	Camshaft Spacer Washer

E-9791HD For 16-1/2" Dia. Cam Brakes

APPLICATION & GENERAL INFORMATION
FOR HENDRICKSON Intraax® 16-1/2" BRAKE

Contains E-1318AHD Heavy-Duty Support Assembly. 1-7/8" bushing and seal O.D.

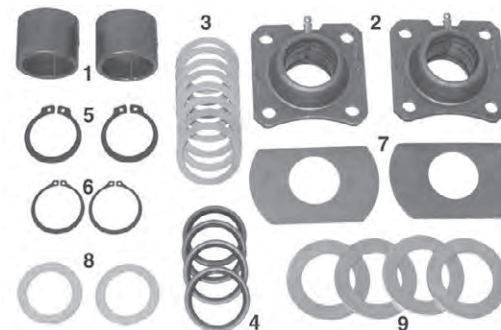





EUCLID NO.	ITEM	QTY	DESCRIPTION
E-807	1	2	Bronze Camshaft Bushing
E-1318AHD	2	2	Camshaft Support Bracket
E-564	3	8	Camshaft Spacer Washer
E-1416	4	4	Camshaft Seal
E-801	5	2	Lock Ring
E-2720	6	2	Camshaft Lock Ring
E-656	7	2	Camshaft "D" Washer
E-1113	8	2	Washer
E-719	9	4	Camshaft Spacer Washer

CAMSHAFT SUPPORT BRACKETS

EUCLID NO.	LOCATION	APPLICATION & GENERAL INFORMATION	REPLACES
E-11445	Left Hand	CAMSHAFT SUPPORT BUSHING ASSEMBLY WITH GREASABLE BUSHING	Leland L3485 Meritor R0011445
E-11446	Right Hand	CAMSHAFT SUPPORT BUSHING ASSEMBLY WITH GREASABLE BUSHING	Leland L3484 Meritor R0011446
E-1319A		FOR MERITOR PAYMASTER AXLE RL and RN MODELS and LATE MODEL TK, TKL, TKD Use with E-1318A or E-1318AHD. Includes mounting screws.	Dayton/Batco 03131 Dayton/Batco 03258 Dayton/Batco 03259 Dayton/Batco 03260 Dayton/Batco 03261 Trailmobile 19096 Dana/Spicer 301361 Meritor 3299H3102 Trailmobile 381319A Sirco B8735 Meritor KIT1759 Leland L1649 Meritor R991006
E-2103		FOR SPICER AND STD. FORGE 12-1/4" DIA. BRAKES Includes: E-2102 Bushing	Dayton/Batco 03115 Dayton/Batco 03126 Standard Forge 209999019 Dana/Spicer 301347 Trailmobile 382103 Sirco B8733 Leland L1718 Dana/Spicer M12WH112 Dana/Spicer M12WH112X Meritor R630002
E-2104		FOR SPICER AND STD. FORGE 16-1/2" DIA. BRAKES Includes: E-2102 Bushing. For Retainer Plates only, order E-2365	Dayton/Batco 03114 Dayton/Batco 03125 Standard Forge 209108001 Standard Forge 209999018 Dana/Spicer 301357 Trailmobile 382104 Sirco B8714 Hercules H8714 Leland L1198 Dana/Spicer M16WH101X Dana/Spicer M16WH113X Meritor R630003
E-2477B		FOR MERITOR 5" ROUND AXLES WITH 16-1/2" DIA. BRAKES Use with E-1318A or E-1318AHD. Includes mounting screws.	Dayton/Batco 03254 Dayton/Batco 03259 Dayton/Batco 03260 Trailmobile 15305 Dana/Spicer 301368 Dana/Spicer 301373 Meritor 3288T5844 Meritor 3299B3824 Meritor 3299U1061 Trailmobile 382477A Trailmobile 382477B Meritor A3299T5844 Sirco B8736 Sirco B8736A Haldex C63143 Leland L1642

CAMSHAFT SUPPORT BRACKETS

EUCLID NO.	LOCATION	APPLICATION & GENERAL INFORMATION	REPLACES
E-603		 <p>FOR EARLY MODEL MERITOR AXLES Use with E-535 Nylon Bushing</p>	Dayton/Batco 03250 Meritor 1205N430 Fruehauf 219157 Dana/Spicer 301362 Trailmobile 38603 Trailmobile 42929 Haldex 65565 Haldex 66552 Navistar 69340R1 Trailmobile 7-13-17 Trailmobile 700736 Sirco B8713 Haldex C65565 Navistar IT301362 Leland L242
E-9785A	Left Hand	 <p>FOR SPICER (DANA) 5" ROUND AXLE WITH 12-1/4" DIA. BRAKES</p>	
E-9786A	Right Hand	 <p>FOR SPICER (DANA) 5" ROUND AXLE WITH 12-1/4" DIA. BRAKES</p>	
E-9787A	Left Hand	 <p>FOR SPICER (DANA) 5" ROUND AXLE WITH 16-1/2" DIA. BRAKES</p>	Dayton/Batco 031142 Dana/Spicer M16WHR50L Meritor R009787A
E-9788A	Right Hand	 <p>FOR SPICER (DANA) 5" ROUND AXLE WITH 16-1/2" DIA. BRAKES</p>	Dayton/Batco 031141 Dana/Spicer M16WHR50R Meritor R009788A

CAMSHAFT SUPPORT BUSHING ASSEMBLY

For Meritor Trailer Axles

Recommended Replacement for Euclid E-1318A

-  **ADVANCED DESIGN — FOR EXTENDED LIFE BRAKES**
-  **EXTENDS CAMSHAFT LENGTH OF SERVICE!**
-  **EUCLID ENGINEERED — PATENT**

E-1318AHD

"Heavy-Duty" — Long Life

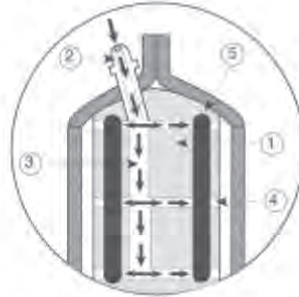

KEY	FEATURE	BENEFIT
1	Bushing is made from molybdenum disulfide impregnated material.	Holds grease better, longer and provides a surface that has greater lubricity.
2	Grease fitting extends directly to inside diameter of the bushing.	Positive greasing action! Grease flows directly to camshaft surface. Only two pumps with a grease gun lubricate this bushing.
3	Wide grease-following groove around the inside diameter of the bushing.	Carries grease completely around the camshaft surface. Camshaft journals do not run "dry", extending camshaft life.
4	Lateral grooves help distribute grease.	Positive greasing action.
5	O-rings installed in grooves inside the bushing.	Seals grease in and contaminants out! Entire assembly lasts longer. Lowers costs and downtime.



EUCLID NO.	REPLACES	APPLICATION
E-1318A	Meritor A1199D2526 Meritor A3105V282	Original OEM style Bushing Assembly.

CAMSHAFT SUPPORT BRACKETS AND ASSEMBLIES



EUCLID NO.	REPLACES	APPLICATION
E-4586	Dayton/Batco 03268	For 16-1/2" Brakes. Used in E-4594 Bracket Assembly
	Dayton/Batco 03273	
	Dana/Spicer 301364	
	Dana/Spicer 301392	
	Trailmobile 384586	
	Fruehauf ACF004024001	
	Fruehauf AXA000403001	
	Sirco B8728	
	Leland L2712	
	Meritor R630006	



E-4587	Dayton/Batco 03272	For 16-1/2" and 12-1/4" Brakes. Sold as Set Only. Includes One of each Retainer Plate. Bushing not included.
	Dana/Spicer 301391	
	Trailmobile 384587	
	Fruehauf ACF004021001	
	Fruehauf ACF004022001	
	Sirco B8727	
	Sirco B8727A	
	Sirco B8727B	
Leland L2711		
Meritor R630007		



EUCLID NO.	REPLACES	APPLICATION	KIT INCLUDES
E-4593	Dayton/Batco 03266	For 12-1/4" Brakes	Includes: 1 pc. E-4585 Bracket (not sold separately); 1 pc. E-4587 Plate Set; 1 pc. E-1577A Bushing
	Dayton/Batco 03271		
	Dana/Spicer 301399		
	Trailmobile 384593		
	Trailmobile 7007218		
	Fruehauf ACF004024902		
	Fruehauf ACF40221		
	Sirco B8726		
	Sirco B8727		
	Leland L2714		
Meritor R630008			



E-4594	Dayton/Batco 03207	For 16-1/2" Brakes. Can Be Assembled as Right or Left	Includes: 1 pc. E-4586 Bracket; 1 pc. E-4587 Plate Set; 1 pc. E-1577A Bushing
	Dayton/Batco 03264		
	Dayton/Batco 03270		
	Dana/Spicer 301398		
	Trailmobile 384594		
	Trailmobile 7007218		
	Trailmobile 7007219		
	Wagner 920510		
	Fruehauf ACF004024900		
	Holland Hitch ACF4024900		
	Sirco B8725		
	Sirco B8725A		
	Haldex C63137		
	Leland L2707		
Leland L3040			
Leland L3228			
Meritor R630009			



EUCLID NO.	REPLACES	DESCRIPTION
E-5476	Dayton/Batco 03140	Cam Support Bracket and Bushing for K-B Axle
	Dayton/Batco 03141	
	Meritor R005476	

CAMSHAFT TUBE ENCLOSURES FOR TRAILERS

- Holds more grease - cams last longer
- Oil-impregnated bushings last longer than nylon

For greater camshaft life where trailer is subjected to extreme operating conditions.

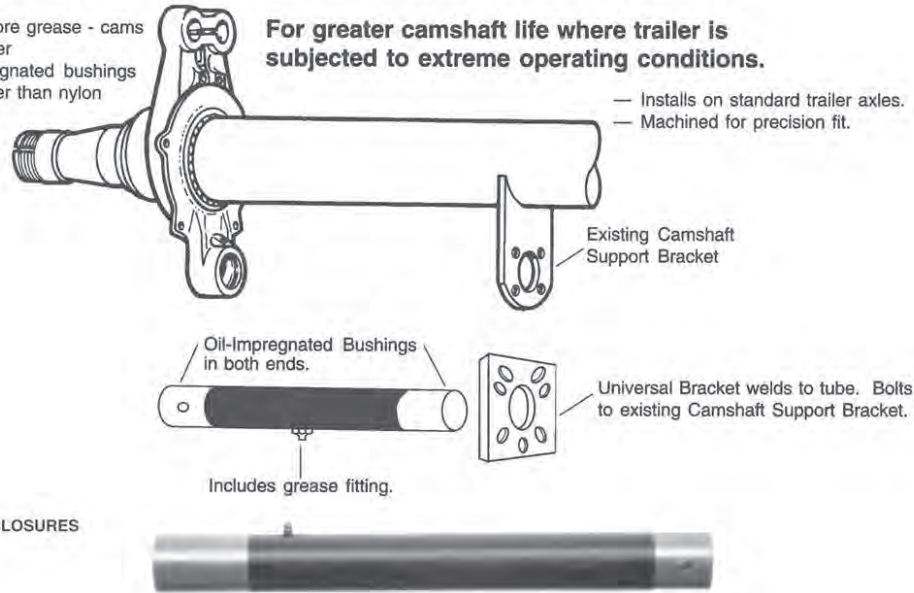

TUBE ENCLOSURES

EUCLID NO.	SPIDER END I.D.	SUPPORT END I.D.	TUBE OAL	TUBE O.D.	CAM LENGTH	CAM APPLICATION
E-9591	1-1/2"	1-1/2"	14-3/4"	1-7/8"	17-5/16"	For Meritor, Dana axles
E-10931	1-1/2"	1-1/2"	15"	1-7/8"	17-3/4"	For Dana axles with 16-1/2" brake
E-9593	1-1/2"	1-1/2"	16"	1-7/8"	18-5/8"	For Meritor, Dana, IMT- Eaton axles
E-4737A	1-1/2"	1-1/2"	17-3/4"	1-7/8"	20-3/8"	For standard 1-1/2" dia. camshaft
E-10934	1-1/2"	1-1/2"	18-1/4"	1-7/8"	21-1/2"	For Dana axles with 12-1/4" brake
E-9597	1-1/2"	1-1/2"	18-1/2"	1-7/8"	21-1/8"	For Dana axles with 12-1/4" brake
E-10932	1-1/2"	1-1/2"	19-5/16"	1-7/8"	22-1/16"	For Dana axles with 16-1/2" brake
E-10933	1-1/2"	1-1/2"	20-1/4"	1-7/8"	23-1/4"	For Dana axles with 12-1/4" brake
E-9596	1-1/2"	1-1/2"	20-1/2"	1-7/8"	23-1/4"	For Dana axles with 12-1/4" brake and air ride suspension
E-4738A	1-1/2"	1-1/2"	20.75"	1-7/8"	23-3/4"	For standard 1-1/2" dia. camshafts with air ride suspension
E-9594	1-1/2"	1-1/2"	21"	1-7/8"	23-3/4"	For Dana axles with Chalmers air ride
E-10936	1-1/2"	1-1/2"	23-1/2"	1-7/8"	26-1/2"	For Dana axles with 12-1/4" brake
E-9590	1-1/2"	1-1/2"	23-1/2"	1-7/8"	26-5/8"	For Standard Forge - IMT with air ride suspension
E-9592	1-1/2"	1-1/2"	23.52"	1-7/8"	26-1/4"	For Dana wide track axles with air ride suspension
E-10937	1-1/2"	1-1/2"	23-7/8"	1-7/8"	26-1/16"	For Dana axles with 16-1/2" brake
E-5242A	1-5/8"	1-1/2"	14-13/16"	2"	17-5/16"	For Meritor axles
E-9601	1-5/8"	1-1/2"	17"	2"	19-1/2"	For Eaton axles
E-10939	1-5/8"	1-1/2"	17-5/8"	2"	20-5/8"	For Dana axles with 16-1/2" brake
E-5243A	1-5/8"	1-1/2"	18"	2"	20-13/32"	For Meritor axles
E-10940	1-5/8"	1-1/2"	18-1/2"	2"	21-1/2"	For Dana axles with 12-1/4" brake and 1-5/8" journal dia. at head
E-10942	1-5/8"	1-1/2"	20-1/4"	2"	23-1/4"	For Dana axles with 12-1/4" brake and 1-5/8" journal dia. at head
E-10943	1-5/8"	1-1/2"	20-5/8"	2"	23-5/8"	For Dana axles with 16-1/2" brake
E-9602	1-5/8"	1-1/2"	21"	2"	23-3/4"	For Eaton axles with air ride suspension
E-10944	1-5/8"	1-1/2"	21"	2"	24"	For Dana axles with 16-1/2" brake
E-5244A	1-5/8"	1-1/2"	21.75"	2"	24-1/16"	For Meritor axles
E-10945	1-5/8"	1-1/2"	23-1/2"	2"	26-1/2"	For Dana axles with 12-1/4" brake and 1-5/8" journal dia. at head
E-4934A	1-5/8"	1-5/8"	13-3/4"	2"	16-1/8"	For Fruehauf axles
E-5241A	1-5/8"	1-5/8"	19"	2"	21-1/8"	For Fruehauf axles with air ride suspension
E-5240A	1-5/8"	1-5/8"	21-1/8"	2"	23-7/8"	For Fruehauf axles with air ride suspension
E-9600	1-7/8"	1-1/2"	13-5/8"	2"	17-5/16"	For Meritor axles with fabricated spiders and bolt-on bushings
E-9598	1-7/8"	1-1/2"	16-3/4"	2"	20-13/32"	For Meritor axles with fabricated spiders and bolt-on bushings
E-9599	1-7/8"	1-1/2"	20-1/2"	2"	24-1/16"	For Meritor axles with fabricated spiders and bolt-on bushings
E-11497	2"	1-1/2"	8 13/16"		11-1/16"	Fore Intraax® with 2" spider hole

CAMSHAFT BUSHINGS



EUCLID NO.	I.D.	O.D.	LENGTH	BUSHING TYPE	REPLACES	APPLICATION AND GENERAL INFORMATION
E-2732	1-1/4"	1-7/16"	1"	Bronze	Dayton/Batco 02228 Dana/Spicer 281262 Haldex 66898 Haldex C66898 Wagner F32976 Wagner FC032976 Leland L1680 Meritor R617011	Available only in Camshaft Repair Kit E-3353A. For Wagner Front Axle Brake.



E-3877	1-1/4"	1-5/8"	1-3/16"	Nylon	Dayton/Batco 02244 Meritor 1225R1136 Sirco B8760 Haldex C63104 Leland L2939	
--------	--------	--------	---------	-------	---	--



E-3447	1-1/4"	1-7/8"	1-5/32"	Nylon	Dayton/Batco 02233 Meritor 1225M897 Dana/Spicer 281263 Haldex 66890 Wagner 921011 Sirco B8754 Haldex C66690 Leland L1746	For Meritor "T" Series.
--------	--------	--------	---------	-------	---	-------------------------



E-5127	1-1/4"	1-7/8"	1-5/16"	Nylon	Dayton/Batco 02225 Eaton 1006530 Eaton 1008220 Dana/Spicer 281264 Eaton 3-2164 Wagner 921010 Eaton 96486 Sirco B8750 Haldex C66837 Leland L2831 Meritor R627029	For Eaton 15" x 4" Single Anchor Pin Front Brake.
--------	--------	--------	---------	-------	---	---



E-2551	1-1/2"	1-7/8" Tapered	1-23/32"	Nylon	Dayton/Batco 02232 Meritor 1225X804 Dana/Spicer 281260 Eaton 294446 Eaton 3-2706 Haldex 67018 Sirco B8665 Haldex C67018 Leland L1641	
--------	--------	-------------------	----------	-------	--	--







E-662	1-1/2"	1-5/8"	1"	Steel	Dayton/Batco 02207 Dayton/Batco 1205302 Meritor 1225J218 Dana/Spicer 281239 Navistar 95373R2 Leland L299	
-------	--------	--------	----	-------	---	--



E-961	1-1/2"	1-5/8"	1-5/16"	Bronze	Dayton/Batco 02227 Dana/Spicer 281248 Leland L415 Meritor R627023	
-------	--------	--------	---------	--------	--	--

CAMSHAFT BUSHINGS

EUCLID NO.	I.D.	O.D.	LENGTH	BUSHING TYPE	REPLACES	APPLICATION AND GENERAL INFORMATION	
	E-712	1-1/2"	1-5/8"	1-1/2"	Bronze	Dayton/Batco 02205 Dayton/Batco 02214 Meritor 1225U151 Dana/Spicer 281246 Haldex 65437 Eaton 820112 Eaton B1738 Haldex C65437 Eaton E1738 Leland L303	
						Dayton/Batco 02229 Dana/Spicer 281261 Haldex 66890 Haldex C66890 Wagner F33602 Wagner FC033602 Leland L1686 Meritor R617012	Available only in Camshaft Repair Kit E-3354. For Wagner Drive Axle Brake.
	E-2716	1-1/2"	1-11/16"	1-11/16"	Bronze	Dayton/Batco 02231 Meritor 1225J634 Trailmobile 19090 Dana/Spicer 281253 Eaton 3-2152 Eaton 92103 Sirco B8614 Navistar IT281253 Leland L1767	Inner bushing for Meritor 5000 Series axles with 1-1/2" diameter camshafts.
						Dayton/Batco 01200 Dayton/Batco 02200 Dayton/Batco 02201 Trailmobile 15108 Trailmobile 15109 Dana/Spicer 281235 Dana/Spicer 281236 Trailmobile 38943 Fruehauf 530596 Haldex 65368 Trailmobile 700734 Wagner 921012 Meritor A1225D420 Meritor A1225V438 Fruehauf ACA003265 Sirco B8635 Haldex C65368 Navistar IT281235K Meritor KIT9033 Leland L752 Meritor R000943	For early model Meritor 500 Series axles. YELLOW half is used on inboard side of spider. WHITE half is used on outboard side of spider. Split bushing. Sold only as a set.
	E-943	1-1/2"	1-7/8"	1-7/8"	Nylon	Dayton/Batco 02210 Meritor 1225L1208 Sirco B8600A Haldex C63107 Leland L3029	
						Dayton/Batco 02210 Meritor 1225L1208 Sirco B8600A Haldex C63107 Leland L3029	
	E-5512	1-1/2"	1-7/8"	1-3/16"	Nylon	Dayton/Batco 02210 Meritor 1225L1208 Sirco B8600A Haldex C63107 Leland L3029	
	E-11951	1-1/2"	1-7/8"	1-3/16"		Meritor 1225C1277	For Meritor 15" and 16-1/2" LX/MX 500 Series Brakes.

CAMSHAFT BUSHINGS

EUCLID NO.	I.D.	O.D.	LENGTH	BUSHING TYPE	REPLACES	APPLICATION AND GENERAL INFORMATION
------------	------	------	--------	--------------	----------	-------------------------------------







E-536	1-1/2"	1-7/8"	1-1/4"	Nylon	Dayton/Batco 02202	
					Dayton/Batco 02210	
					Eaton 1000035	
					Dana/Spicer 11008	
					Navistar 122407R1	
					Meritor 1225L1208	
					Meritor 1225N378	
					Navistar 1691529C1	
					GMC 2309474	
					Dana/Spicer 281233	
					Dana/Spicer 281244	
					Eaton 3-2149	
					Eaton 3-2163	
					Trailmobile 38536	
					Standard Forge 405126	
					Trailmobile 42922	
					Fruehauf 515147	
					Haldex 65329	
					Trailmobile 7-6-17	
					Trailmobile 700732	
					Eaton 820183	
					Eaton 91007	
					Wagner 921000	
					Eaton 96120	
					Eaton B1581	
					Eaton B2021	
					Sirco B8600	
					Sirco B8600A	
					Haldex C65329	
					Eaton E1581	
					Eaton EB1000035	
					Navistar IT281233	
Meritor KIT8023						
Leland L166						
Leland L1727						
Meritor R617004						







E-667	1-1/2"	1-7/8"	1-1/4"	Bronze	Dayton/Batco 02206	Bronze version of E-536 and E-1364.
					Dayton/Batco 02211	
					Eaton 1003000	
					Meritor 1225R512	
					Meritor 1225X336	
					Dana/Spicer 281234	
					Trailmobile 38667	
					Dana/Spicer 405106	
					Haldex 65441	
					Wagner 921007	
					Sirco B667	
					Haldex C63109	
					Navistar IT281234	
					Leland L330	
					Dana/Spicer M16HD100	
Meritor R657005						





CAMSHAFT BUSHINGS

EUCLID NO.	I.D.	O.D.	LENGTH	BUSHING TYPE	REPLACES	APPLICATION AND GENERAL INFORMATION
	1-1/2"	1-7/8"	1-1/2"	Nylon	Dayton/Batco 02203	
					Dana/Spicer 281232	
					Eaton 3-2147	
					Trailmobile 38759	
					Standard Forge 405129	
					Haldex 65384	
					Eaton 90276	
					Wagner 921001	
					Sirco B8602	
					Haldex C65384	
					Hercules H8602	
					Navistar IT281232	
					Leland L1356	
					Leland L1536	
Leland L389						
Leland L599						
Meritor R617001						
Meritor R617003						
Meritor R657002						
	1-1/2"	1-7/8"	1-1/2"	Bronze	Dayton/Batco 02204	Bronze version of E-759 and E-1365.
					Dana/Spicer 281231	
					Trailmobile 38807	
					Standard Forge 405133	
					Haldex 65359	
					Sirco B807	
					Haldex C65359	
					Navistar IT281231	
					Leland L402	
					Dana/Spicer M16HD100	
Meritor R657001						
	1-1/2"	1-7/8"	2"	Bronze	Dayton/Batco 03203	Bronze version of E-661.
					Dana/Spicer 281258	
					Trailmobile 38602	
					Standard Forge 405123	
					Navistar IT281258	
					Leland L203	
					Dana/Spicer M10WJ182	
					Meritor R627022	
Standard Forge UB1126						
	1-1/2"	1-7/8"	2"	Nylon	Dayton/Batco 02213	
					Dayton/Batco 03201	
					Dana/Spicer 11019	
					Dana/Spicer 281257	
					Trailmobile 38661	
					Standard Forge 405109	
					Haldex 65434	
					Trailmobile 700765	
					Wagner 921002	
					Sirco B8601	
					Haldex C65434	
Navistar IT281257						
Leland L266						
Dana/Spicer M10WJ178						
Meritor R617001						
	1-1/2"	2"	1-1/2"		Dayton/Batco 02257	Bronze. For Hendrickson Intraax® 16-1/2" brake.
					Hendrickson Turner B28898	
					Sirco B806	
					Hendrickson Turner S22898	

CAMSHAFT BUSHINGS

EUCLID NO.	I.D.	O.D.	LENGTH	BUSHING TYPE	REPLACES	APPLICATION AND GENERAL INFORMATION
	1-1/2"	2-1/8"	1"	Nylon	Dayton/Batco 03212	NOTE: For use in E-1318A Assembly Only. Do not use in E-1318AHD. Use E-1314 O-Ring on each side.
					Meritor 1125P640	
					Meritor 1225P640	
					Meritor 1225R1058	
					Dana/Spicer 271197	
					Eaton 3-2161	
					Trailmobile 382361	
					Haldex 66646	
					Trailmobile 700737	
					Wagner 921005	
					Eaton 95390	
					Sirco B8636	
					Haldex C66646	
					Navistar IT271197	
Leland L1730						
	1-1/2"	2-15/32"	1-1/2"	Nylon	Dayton/Batco 03210	
					Dana/Spicer 11109	
					Dana/Spicer 271191	
					Dana/Spicer 271192	
					Eaton 3-2160	
					Trailmobile 382517	
					Haldex 67358	
					Eaton 95025	
					Sirco B8699	
					Haldex C67358	
Leland L1711						
Dana/Spicer M10WJ100						
Meritor R617008						
	1-1/2"	2-15/32"	1-3/4"	Nylon	Dayton/Batco 03208	
					Dana/Spicer 271195	
					Eaton 3-2159	
					Trailmobile 382102	
					Standard Forge 405128	
					Haldex 65476	
					Trailmobile 700767	
					Wagner 921004	
					Eaton 94659	
					Sirco B8606	
					Haldex C65476	
Leland L1199						
Dana/Spicer M10WJ107						
Dana/Spicer M10WJ212X						
Meritor R617002						
E-9792A	1-1/2"	2-15/32"	1-3/4"	Nylon	Sirco B8606A	Greaseless Nylatron version of E-2102.
					Leland L3146	
					Meritor R617015	
	1-1/2"	2-3/4"	2"	Molybdenum	Dayton/Batco 03202	
					Dana/Spicer 271199	
					Trailmobile 381385	
					Haldex 67361	
					Eaton 820185	
					Eaton B2028A	
					Sirco B8616	
					Haldex C67361	
					Leland L1594	
					Meritor R627009	

CAMSHAFT BUSHINGS

EUCLID NO.	I.D.	O.D.	LENGTH	BUSHING TYPE	REPLACES	APPLICATION AND GENERAL INFORMATION	
	E-2695	1-1/2"	2-3/4"	2-1/2"	Nylon	Dayton/Batco 03214	Eaton 501 Series. Includes 2 E-1416A Seals.
						Eaton 1002262	
						Dana/Spicer 271196	
						Eaton 297733	
						Eaton 3-2715	
						Trailmobile 382695	
						Haldex 67362	
						Trailmobile 7007181	
						Wagner 921009	
						Sirco B8688	
						Haldex C67362	
						Navistar IT271196	
						Leland L1598	
						Meritor R617006	
	E-535	1-1/2"	2-3/4"	2-1/2"	Nylon	Dayton/Batco 03200	
						GMC 2305192	
						Dana/Spicer 271200	
						Eaton 3-2155	
						Trailmobile 38535	
						Standard Forge 405125	
						Trailmobile 43287	
						Fruehauf 515148	
						Navistar 56119R98	
						Fruehauf 61608	
						Haldex 65330	
						Trailmobile 7-6-18	
						Trailmobile 700735	
						Wagner 921003	
Eaton 93198							
Meritor A3299G1541							
Sirco B8603							
Navistar IT271200							
Leland L167							
	E-1577A	1-19/32"	2-1/2"	1-1/2"	Nylon	Dayton/Batco 03207	
						Dana/Spicer 271194	
						Eaton 3-2158	
						Trailmobile 381577A	
						Haldex 66645	
						Trailmobile 700768	
						Wagner 921008	
						Eaton 94294	
						Fruehauf ACD002285900	
						Fruehauf ACD2285900	
						Sirco B8624	
						Haldex C66645	
						Navistar IT271194	
						Leland L1191	
Meritor R617009							
	E-1571	1-19/32"	2-7/8"	2-1/2"	Nylon	Dayton/Batco 03206	For "Pro-Par" Axle
						Dana/Spicer 271198	
						Eaton 3-2157	
						Trailmobile 381571	
						Haldex 65380	
						Trailmobile 700764	
						Wagner 921006	
						Eaton 93929	
						Fruehauf AXA000429900	
						Fruehauf AXA000429PKG	
						Fruehauf AXA0429900	
						Sirco B8623	
						Haldex C65380	
						Navistar IT271198	
Leland L898							
Meritor R617007							

CAMSHAFT BUSHINGS



EUCLID NO.	I.D.	O.D.	LENGTH	BUSHING TYPE	REPLACES	APPLICATION AND GENERAL INFORMATION
E-1567	1-5/8"				Dayton/Batco 02220 Dana/Spicer 281237 Eaton 3-2150 Trailmobile 381567 Haldex 65378 Trailmobile 700762 Eaton 91372 Wagner 921013 Fruehauf AXA000413900 Fruehauf AXA0413900 Sirco B8620 Haldex C65378 Navistar IT281237 Leland L896 Meritor R657003	NOTE: Uses 2 bushings per Spider.



E-2408	1-5/8"	1-7/8"	1-1/8"		Dayton/Batco 02242 Meritor 1225B834 Dana/Spicer 281241 Eaton 3-2154 Trailmobile 382408 Eaton 92833 Sirco B8627 Leland L1296	Inner bushing for Meritor 4000-6000 Series 121 axles with 1-5/8" diameter camshafts.
--------	--------	--------	--------	--	--	--



E-6080	1-5/8"	2"	1"	Powdered metal	Dayton/Batco 02246 Meritor 1225N1158 Trailmobile 386080 Sirco B8782 Haldex C63112 Leland L2942	Powdered Metal Bushing for Meritor Axles with cast spiders.
--------	--------	----	----	----------------	---	---



E-2690A	1-5/8"	2"	1-3/16"	Nylon	Dayton/Batco 02224 Eaton 1002248 Eaton 1008412 Dana/Spicer 281238 Eaton 297368 Eaton 3-2714 Trailmobile 382690A Haldex 67364 Trailmobile 7007205 Wagner 921014 Sirco B8698 Leland L1597 Leland L2382 Meritor R617005	
---------	--------	----	---------	-------	---	--



E-9789	1-5/8"	2"	1-1/2"	Bronze	Dayton/Batco 02256 Sirco B805 Haldex C63113 Leland L3127 Dana/Spicer M16D106 Meritor R627034	
--------	--------	----	--------	--------	---	--



E-2380	1-3/4"	1-7/8"	1-5/16"		Dayton/Batco 02230 Meritor 1225A781 Meritor 1225G631 Trailmobile 19089 Dana/Spicer 281252 Eaton 3-2151 Eaton 91737 Sirco B8615 Navistar IT281252 Leland L1766	Outer bushing for Meritor 5000 Series axles with 1-1/2" diameter camshafts.
--------	--------	--------	---------	--	--	---

CAMSHAFT BUSHINGS



EUCLID NO.	I.D.	O.D.	LENGTH	BUSHING TYPE	REPLACES	APPLICATION AND GENERAL INFORMATION
E-2407	1-7/8"	2"	1-5/16"		Dayton/Batco 02241 Meritor 1225A833 Dana/Spicer 281240 Eaton 3-2153 Trailmobile 382407 Eaton 92468 Sirco B8628 Leland L1294	Outer bushing for Meritor 4000-6000 Series 121 axles with 1-5/8" diameter camshafts.

FOR MERITOR FABRICATED SPIDERS WITH BOLT-ON BUSHING OR WELD-ON BUSHING RETAINER



EUCLID NO.	I.D.	LENGTH	REPLACES	GENERAL INFORMATION
E-11952	1-5/8"	1-13/16"	Meritor A1-3105Q1213	Services one spider.



E-6076	1-5/8"	1-13/16"	Dayton/Batco 02248 Dana/Spicer 301381 Trailmobile 386076 Meritor A3105L1078 Sirco B8783 Haldex C63140 Hercules H8783 Leland L3033 Leland L3042	Services one spider.
---------------	--------	----------	--	----------------------

FOR MERITOR FABRICATED SPIDERS WITH BOLT-ON BUSHING OR WELD-ON BUSHING RETAINER



EUCLID NO.	I.D.	O.D.	LENGTH	REPLACES	GENERAL INFORMATION
E-9784	2"	2-3/8"	1-9/16"	Meritor A3105D1148	For Retrofit on Bolt-on Bushing Spiders. Services one spider. For use with E-2670 bushing assembly or E-6080 powdered metal bushing.



E-9783	2"	2-1/2"	1-9/16"	Dayton/Batco 02249 Meritor A3105K219 Haldex C63142 Leland L3224	Services one spider. For use with E-2670 bushing assembly or E-6080 powdered metal bushing.
---------------	----	--------	---------	--	---

CAMSHAFT SPIDER BUSHING KITS

CAMSHAFT SPIDER BUSHING ASSEMBLY INSTALLATION INSTRUCTIONS

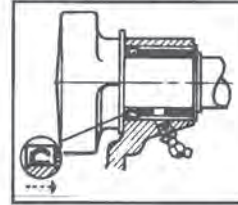

Sealing lip of grease seal should be turned toward inside of spider housing at camshaft head.

EUCLID NO.	INCLUDES	QTY.	DESCRIPTION	REPLACES	APPLICATION INFORMATION
E-2291	E-1416	1	Camshaft Seal	Dayton/Batco 02218	For Meritor 5000 Series Axles with 1-1/2" Dia. Camshafts
	E-2380	1	Camshaft Outer Bushing	Dana/Spicer 281255	
	E-1271	1	Camshaft Inner Bushing	Trailmobile 382291	
	E-1272	1	Camshaft Seal	Haldex 65375	
				Trailmobile 700733	
				Wagner 921016	
				Sirco B8660	
				Sirco B8661	
				Haldex C65375	
				Hercules H8660	
				Navistar IT281255	
				Meritor KIT9036	
				Leland L891	
E-2670	E-2405	1	Camshaft Seal	Dayton/Batco 02240	Meritor 4000-6000 Series 121 Axles with 1-5/8" Dia. Camshafts
	E-2407	1	Camshaft Outer Bushing	Dana/Spicer 281243	
	E-2408	1	Camshaft Inner Bushing	Trailmobile 382670	
	E-2406	1	Camshaft Seal	Haldex 66831	
				Trailmobile 700761	
				Wagner 921020	
				Sirco B8660	
				Sirco B8661	
				Haldex C66831	
				Hercules H8661	
				Navistar IT281243	
				Meritor KIT9034	
				Leland L1305	

CAMSHAFT SEALS



EUCLID NO.	REPLACES	I.D.	O.D.	THICK	APPLICATION
E-3878	Dayton/Batco 02318	13/16"	1-3/4"	1/4"	For Meritor 15" x 4" Front Brakes
	Dayton/Batco 02319				
	Meritor A1205D2110				
	Sirco B8761				
	Leland L2938				



E-1272	Dayton/Batco 02306	1-13/64"	1-3/4"	1/8"	For Pre-121 Meritor Axles. Use on inboard side of Spider
	Meritor 1205N924				
	Trailmobile 19085				
	Dana/Spicer 281267				
	Dana/Spicer 291267				
	Eaton 3-2166				
	Eaton 97216				
	Sirco B8613				
Navistar IT291267					
Leland L1768					

E-5128	Dayton/Batco 02315	1-1/4"	1-7/8"	1/16"	For Eaton 15" x 4" Single Anchor Pin Front Brake
	Eaton 1005846				
	Dana/Spicer 291285				
	Eaton 3-2173				
	Wagner 921031				
	Eaton 99773				
	Sirco B8751				
	Haldex C66838				
Leland L2830					
Meritor R627030					

E-3469	Dayton/Batco 02316	1-1/4"	2-1/16"	1/4"	For 1-1/4" Dia. Camshaft
	Dana/Spicer 2291283				
	Haldex 66691				
	Wagner 921029				
	Meritor A1205P1602				
	Sirco B8755				
Haldex C66691					
Leland L1744					



E-11451	Hendrickson Turner A22885	1-1/2"	2"	3/16"	For Hendrickson Intraax® 16-1/2" brake.
	Hendrickson Turner S22885				

E-1416	Dayton/Batco 01465	1-1/2"	1-7/8"	3/16"	For 1-1/2" Dia. Camshafts. Use with Late Model Meritor and Std. Forge Weld-on Spiders
	Dayton/Batco 02312				
	Meritor 1205M1105				
	Dana/Spicer 291269				
	Eaton 3-2169				
	Eaton 32172				
	Trailmobile 381416				
	Standard Forge 408101				
	Haldex 65383				
	Trailmobile 700739				
	Eaton 820110				
	Wagner 921026				
	Eaton 98312				
	Sirco B8612				
Haldex C65383					
Leland L1770					
Dana/Spicer M16HH100					
Meritor R627018					

CAMSHAFT SEALS



EUCLID NO.	REPLACES	I.D.	O.D.	THICK	APPLICATION
E-1416A	Dayton/Batco 02304	1-1/2"	1-7/8"	1/4"	Same as E-1416 except 1/4" thick. Cannot be used on Late Model Meritor Axles
	Dayton/Batco 02353				
	Eaton 1008047				
	Dana/Spicer 291266				
	Trailmobile 381416A				
	Eaton 40864				
	Haldex 67363				
	Eaton 79903				
	Eaton 820111				
	Wagner 921027				
	Eaton B1736				
	Sirco B8612A				
	Haldex C66563				
	Eaton E1736				
	Leland L966				
	Meritor R627008				







E-1314	Dayton/Batco 02314	1-1/2"	1-29/32"	.21"	For 1-1/2" Dia. Camshaft. Use in E-1318AHD Assembly
	Dayton/Batco 03213				
	Meritor 1205X726				
	Navistar 20966R1				
	Dana/Spicer 271208				
	Dana/Spicer 291280				
	Eaton 3-2162				
	Trailmobile 381314				
	Haldex 67359				
	Trailmobile 7007192				
	Eaton 95755				
	Sirco B8621				
Navistar IT271208					
Leland L1307					
Leland L1729					
Meritor R627019					



E-2717	Dayton/Batco 02317	1-1/2"	2"	3/16"	For Wagner Drive Axle Brake
	Dana/Spicer 291282				
	Haldex 66891				
	Sirco B717				
	Haldex C66891				
	Wagner FC031933				
	Leland L1687				
Meritor R627026					

CAMSHAFT SEALS

EUCLID NO.	REPLACES	I.D.	O.D.	THICK	APPLICATION	
	Dayton/Batco 02300					
	Meritor 1205V1556					
	Meritor 1705M143					
	Dayton/Batco 2356					
	Dana/Spicer 291270					
	Dana/Spicer 291281					
	Eaton 3-2165					
	Navistar 352680C91					
	Trailmobile 38654					
	Standard Forge 408100					
	Standard Forge 408103					
	Navistar 56121R2					
	Navistar 56121R3					
	Haldex 65352					
	Haldex 66563					
	Trailmobile 700773	1-1/2"	2-1/16"	1/4"	For 1-1/2" Dia. Camshaft	
	Eaton 820064					
	Wagner 921030					
	Eaton 96851					
	Meritor A1205V1556					
	Eaton B1662					
	Sirco B8609					
	Haldex C65352					
	Eaton E1662					
	Navistar IT291270					
	Meritor KIT8023					
	Leland L1726					
Leland L1728						
Leland L329						
Dana/Spicer M10HH134						
	E-10848	Meritor A1205F136	1-1/2"	2-19/32"	1/4"	For Type 1 Series Meritor Coach Brakes
	E-2406	Dayton/Batco 02309				
		Meritor 1205V1452				
		Dana/Spicer 281275				
		Dana/Spicer 291275				
		Eaton 3-2168	1-5/8"	1-7/8"	1/8"	For Meritor 4000-6000 Series Axles. Use on inboard side of Spider
		Haldex 65494				
		Eaton 97947				
		Sirco B8626				
	Haldex C65494					
	Leland L1295					
	E-3991	Sirco B8764	1-5/8"	2"	3/16"	For use with E-2690A Bushing in Meritor Trailer Axle Spiders
	Haldex C66421					

CAMSHAFT SEALS



EUCLID NO.	REPLACES	I.D.	O.D.	THICK	APPLICATION
E-2405	Dayton/Batco 02310				For Meritor 4000-6000 Series Axles. Use on cam head side. For Eaton "501" Series Brake
	Dayton/Batco 02313				
	Eaton 1002279				
	Meritor 1205Q2123				
	Meritor 1205U1451				
	Dana/Spicer 291271				
	Dana/Spicer 291274				
	Eaton 3-2167				
	Eaton 32717				
	Trailmobile 382405				
	Haldex 65491	1-5/8"	2"	1/4"	
	Trailmobile 7007178				
	Wagner 921028				
	Eaton 97581				
	Sirco B8625				
	Sirco B8721				
	Haldex C65491				
	Leland L1293				
	Leland L1611				
Leland L2941					
Meritor R627015					



E-3859	Dayton/Batco 01329				For outside diameter of Meritor Drive Axle Cam Tubes
	Dayton/Batco 02326				
	Meritor 1205G761				
	Meritor 1779J1024				
	Dana/Spicer 271203				
	Dana/Spicer 301375	1-7/8"	2-1/16"	1/8"	
	Navistar 417488C1				
	Sirco B8690				
	Haldex C65750				
	Leland L1662				
Leland L3056					

CAMSHAFT SPACERS



EUCLID NO.	REPLACES	O.D.	I.D.	THICK	APPLICATION INFORMATION
E-10849	Meritor 2258E499	1-1/2"	17/32"		"W" Series 14-1/2 For Meritor Coach Type 1



E-3474	Dayton/Batco 04346				Nylon. For 15" x 3-1/2" and 15" x 4" T-Series Type 2 Brakes. Available in Camshaft Repair Kit E-3446
	Meritor 1225C939				
	Dana/Spicer 291336	1-7/8"	1-1/2"	9/32"	
	Wagner 921041				
	Haldex C66695				
Leland L1745					

CAMSHAFT SPACER WASHERS



EUCLID NO.	REPLACES	O.D.	I.D.	THICK	PLATING	APPLICATION INFORMATION
E-10851	Meritor 1229T1164	1-1/2"	17/32"	1/8"	Plated	Use with Meritor Coach 14-1/2"
E-2733	Dayton/Batco 04347				Plated	For Wagner Front Axle Brake
	Dayton/Batco 04348					
	Dana/Spicer 291331					
	Trailmobile 382733					
	Haldex 66899	1-3/4"	1-1/4"	1/8"		
	Haldex C66899					
	Wagner FC003002					
Leland L1681						
Meritor R627028						
E-5095	Meritor 1229J3130				None	Meritor/Mack "Q" Brakes
	Sirco B8762	1-7/8"	1-1/4"	1/32"		
	Haldex C65381					

CAMSHAFT SPACER WASHERS

EUCLID NO.	REPLACES	O.D.	I.D.	THICK	PLATING	APPLICATION INFORMATION
E-1113	Dayton/Batco 01472					
	Dayton/Batco 04309					
	Eaton 102330					
	Meritor 1229B1848					
	Meritor 1229G2971					
	Meritor 1229Q433					
	Trailmobile 15408					
	Eaton 3-2180					
	Dana/Spicer 351580					
	Trailmobile 381113	1-7/8"	1-17/64"	1/16"	Plated	Anchor Pin Washer for Meritor 4000-6000 Series Axle Spline End
	Haldex 65373					
	Trailmobile 700729					
	Eaton 820182					
	Wagner 914054					
	Eaton B2019					
Sirco B988						
Haldex C65373						
Navistar IT351580						
Leland L889						
E-1781	Dayton/Batco 04308					
	Eaton 100869					
	GMC 2277334					
	Eaton 23470					
	Eaton 23570					
	Dana/Spicer 291320					
	Eaton 3-2176	2"	1-9/64"	1/32"	Plated	Used on Eaton Self-Contained Brake
	Haldex 67374					
	Navistar 67678R1					
	Wagner 921057					
	Sirco B8630					
	Haldex C67374					
	Leland L1608					
	Meritor R627006					
	E-1782	Dayton/Batco 04307				
Eaton 101234						
Dana/Spicer 291321						
Eaton 3-2177						
Eaton 34528						
Eaton 35428		2"	1-9/64"	1/16"	Plated	Used on Eaton Self-Contained Brake
Wagner 921059						
Navistar 97999R1						
Sirco B8629						
Haldex C67375						
Leland L1609						
Meritor R627005						



CAMSHAFT SPACER WASHERS

EUCLID NO.	REPLACES	O.D.	I.D.	THICK	PLATING	APPLICATION INFORMATION
E-564	Dayton/Batco 02350					
	Eaton 102330					
	Meritor 1229J868					
	Eaton 2-2134					
	GMC 2101126					
	Fruehauf 219179					
	Fruehauf 219179PKG					
	Eaton 2807928					
	Dana/Spicer 291309					
	Eaton 3-2180					
	Trailmobile 37829					
	Standard Forge 403107	2"	1-17/32"	3/64"	Plated	Also used on Meritor RN/RL Series
	Haldex 65313					
	Trailmobile 7-27-3					
	Trailmobile 700794					
	Eaton 85500					
	Wagner 921044					
Eaton B1221						
Sirco B8610						
Haldex C65313						
Navistar IT291309						
Leland L120						
Dana/Spicer M10HN139						
E-5138	Dayton/Batco 04150811					
	Dayton/Batco 04351					
	Eaton 1005203					
	Dana/Spicer 291346					
	Eaton 3-2106					
	Eaton 75301	2-1/4"	1-1/4"	1/32"	Plated	Outer Shim Washer For Eaton 15" x 4" Single Anchor Pin Front Brakes
	Wagner 921049					
	Sirco B8753					
	Haldex C66840					
	Leland L2833					
Meritor R627032						
E-5137	Dayton/Batco 04350					
	Eaton 100503					
	Eaton 1005202					
	Dana/Spicer 291344					
	Eaton 3-2175					
	Wagner 921048	2-1/4"	1-1/4"	1/16"	Plated	Inner Shim Washer For Eaton 15" x 4" Single Anchor Pin Front Brakes
	Sirco B8752					
	Haldex C66839					
Leland L2832						
Meritor R627031						
E-10845	Dayton/Batco 04301	2-1/4"	1-15/32"	1/32"		Use with Meritor Coach 14-1/2"
	Meritor 1229X2936					
E-581	Dayton/Batco 04301					
	Meritor 1229Q771					
	Fruehauf 219292					
	Dana/Spicer 291308					
	Trailmobile 38581					
	Trailmobile 40733					
	Navistar 56115R1					
	Haldex 65338	2-1/4"	1-17/32"	1/32"	Plated	Used on all 1-1/2" dia. Camshafts
	Trailmobile 7-9-11					
	Trailmobile 700740					
	Wagner 921046					
	Sirco B8605					
	Haldex C65339					
Navistar IT291308						
Leland L192						



CAMSHAFT SPACER WASHERS

EUCLID NO.	REPLACES	O.D.	I.D.	THICK	PLATING	APPLICATION INFORMATION
E-580	Dayton/Batco 02350					
	Dayton/Batco 04302					
	Eaton 102695					
	Meritor 1229R122					
	Navistar 185843R1					
	Fruehauf 219293					
	Dana/Spicer 291307					
	Eaton 3-2181					
	Trailmobile 37811					
	Trailmobile 38580					
	Dayton/Batco 4307					
	Eaton 43943	2-1/4"	1-17/32"	1/16"	Plated	Use on all 1-1/2" dia. Camshafts Including End Washer for Fruehauf "Pro-Par" Camshaft
	Navistar 56116R1					
	Haldex 65339					
	GMC 658049					
	Trailmobile 7-9-3					
	Trailmobile 700741					
	Eaton 820009					
	Wagner 921047					
	Fruehauf AXA000432001					
Eaton B1216						
Sirco B8607						
Haldex C65338						
Leland L193						
Dayton/Batco 04328						
Dana/Spicer 291326						
Standard Forge 403149						
Haldex 66859						
Haldex 6689						
Sirco B8632	2-1/4"	1-17/32"	3/32"	Plated	For Late Model Std. Forge 12-1/4" Brake and Wagner Front Axle Brake	
Haldex C66859						
Wagner FC031954						
Navistar IT291326						
Leland L1371						
Dana/Spicer M10HS117						
Meritor R627025						
Dayton/Batco 04361						
Meritor 1229B4136						
Sirco B8786	2-1/4"	1-5/8"	1/32"	None	16-1/2" Q Plus™ Brakes	
Haldex C63157						
Leland L3058						
Leland L3068						
Dayton/Batco 04320						
Dayton/Batco 04358						
Eaton 105617						
Meritor 1229F2502						
Meritor 1229X3118						
Dana/Spicer 291312						
Dana/Spicer 291327						
Eaton 3-2189	2-1/4"	1-5/8"	1/16"	Plated	For Meritor 4000-6000 Series Axle Cam End	
Trailmobile 382411A						
Trailmobile 7007144						
Wagner 921045						
Sirco B8633						
Sirco B960						
Haldex C66852						
Leland L1297						
Leland L2947						



E-2409

CAMSHAFT SPACER WASHERS

EUCRID NO.	REPLACES	O.D.	I.D.	THICK	PLATING	APPLICATION INFORMATION
E-3476	Dayton/Batco 04347	2-3/8"	1-9/32"	1/8"	None	15" x 3-1/2" and 15" x 4" T-Series Type 2 Brakes
	Meritor 1229Q277					
	Dana/Spicer 291330					
	Haldex 66693					
	Wagner 921050					
	Sirco B8757					
	Haldex C66693					
Leland L1747						
E-3479	Dayton/Batco 04322	2-3/8"	1-1/2"	7/64"	Plated	Late Model "Q" Brake
	Eaton 105982					
	Meritor 1229S2697					
	Dana/Spicer 291345					
	Eaton 3-2190					
	Trailmobile 383479					
	Haldex 66699					
	Sirco B8719					
Haldex C66699						
Leland L2928						
E-9072	Meritor 1229S4101	2-3/8"	1-5/8"	3/32"	Plated	Inner Washer for E-6076 Bolt-on Bushing
	Sirco B8785					
	Haldex C63158					
	Leland L3058					
E-1565	Dayton/Batco 04304	2-3/8"	1-41/64"	1/16"	Plated	For "Pro-Par" Axle
	Eaton 103425					
	Dana/Spicer 291322					
	Eaton 3-2183					
	Trailmobile 381565					
	Haldex 65377					
	Trailmobile 7007121					
	Wagner 921053					
	Fruehauf AXA000417001					
	Holland Hitch AXA0417					
	Holland Hitch AXA04171					
	Sirco B8619					
	Haldex C65377					
	Navistar IT291322					
Leland L1612						
Leland L895						
Meritor R627002						
E-3475	Dayton/Batco 04345	2-7/16"	1-9/32"	1/32"	None	15" x 3-1/2" and 15" x 4" T-Series Type 2 Brakes
	Meritor 1107D56					
	Dana/Spicer 291334					
	Wagner 921051					
	Sirco B8758					
	Haldex C66695					
	Leland L1748					
E-719	Dayton/Batco 04303	2-7/16"	1-9/16"	1/8"	Plated	Also used on Meritor and Shuler Axles
	Dana/Spicer 291311					
	Eaton 296272					
	Eaton 3-2711					
	Trailmobile 38719					
	Standard Forge 403105					
	Haldex 65374					
	Wagner 921054					
	Sirco B8611					
	Haldex C65374					
	Leland L344					
Dana/Spicer M10SS100						
Meritor R627011						
E-10800	Sirco B800	2-7/16"	1-11/16"	1/8"	None	
	Meritor R627043					



CAMSHAFT SPACER WASHERS

EUCLID NO.	REPLACES	O.D.	I.D.	THICK	PLATING	APPLICATION INFORMATION
E-3471	Dayton/Batco 04340	2-1/2"	1-5/16"	1/16"	None	15" x 3-1/2" and 15" x 4" T-Series Type 2 Brakes
	Meritor 1229B236					
	Dana/Spicer 291338					
	Haldex 66692					
	Trailmobile 7007174					
	Wagner 921052					
	Sirco B8756					
	Haldex C66692					
Leland L1743						
E-3472	Dayton/Batco 04341	2-3/4"	1-1/2"	1/8"	None	16-1/2" x 3" T-Series Brakes
	Meritor 1229P302					
	Navistar 228884R1					
	Dana/Spicer 291333					
	Haldex 66697					
	Sirco B230					
	Haldex C66697					
	Leland L1753					
E-3473	Dayton/Batco 04332	3-1/8"	1-33/64"	1/16"	None	15" x 3-1/2" and 15" x 4" T-Series Type 1 Brakes
	Dayton/Batco 04339					
	Meritor 1229E811					
	Dana/Spicer 291325					
	Dana/Spicer 291337					
	Trailmobile 383473					
	Eaton 820114					
	Wagner 921055					
	Eaton B1740					
	Sirco B811					
	Haldex C66696					
	Leland L1633					
Leland L1724						
Meritor R627007						
E-3477	Dayton/Batco 04344	3-1/8"	1-17/32"	1/8"	None	16-1/4" x 3-1/2" T-Series Brakes
	Navistar 110542R2					
	Meritor 1229F1618					
	Dana/Spicer 291335					



CAMSHAFT WASHERS

EUCLID NO.	REPLACES	O.D.	I.D.	THICK	APPLICATION INFORMATION
E-3478	Dayton/Batco 04334			1/16"	For Meritor "Q" Service Brakes
	Eaton 106713				
	Meritor 1229E4685S				
	Dana/Spicer 291339				
	Eaton 3-2192				
	Sirco B8718				
	Haldex C67001				
	Leland L2927				
E-5482	Dayton/Batco 04357			1/16"	Cam Head Washer for Eaton "ES" Brakes
	Eaton 2806380				
	Sirco B8763				
	Haldex C63163				
	Leland L2963				
	Meritor R627033				
E-9071	Dayton/Batco 04338			1/16"	For 2-1/2" offset spiders
	Meritor 1229-F-4686				
	Meritor 1229X2260				
	Sirco B8781				
	Haldex C63165				
	Haldex C63465				
	Leland L3041				
Leland L3363					



CAMSHAFT WASHERS



EUCLID NO.	REPLACES	O.D.	I.D.	THICK	APPLICATION INFORMATION
E-9075	Dayton/Batco 04362 Meritor 1229C4137 Sirco B8787 Haldex C63153 Leland L2944	2-3/8"	1-41/64"	11/32"	Use with press-in nylon or metal Spider Bushings and Camshafts with 2" upper bearing journals



E-10857	Meritor 1229S435	2-7/16"	1-17/32"	1/16"	For Meritor "W" Series 14-1/2"
----------------	------------------	---------	----------	-------	--------------------------------



E-10801	Sirco B801 Meritor R627044	2-7/16"	1-11/16"	1/16"	For Late Model Std. Forge 12-1/4" Brake
----------------	-------------------------------	---------	----------	-------	---



E-6077	Dayton/Batco 04321 Meritor 1229R4100 Sirco B8784 Haldex C63164 Leland L3057	2-11/16"	1-5/8"	1/16"	Cam Head Washer for Meritor Trailer Axles with Fabricated Spiders
---------------	---	----------	--------	-------	---



E-10843	Meritor 1229S747	2-3/4"	1-9/16"	1/16"	For Meritor "W" Series 14-1/2"
----------------	------------------	--------	---------	-------	--------------------------------



E-2404	Dayton/Batco 04327 Dana/Spicer 291319 Standard Forge 403150 Sirco B8631 Haldex C65488 Leland L1372 Dana/Spicer M10HS115 Meritor R627024	3-7/8" x 2-7/16"	1-17/32"	1/16"	For Late Model Std. Forge 12-1/4" Brake
---------------	--	---------------------	----------	-------	---



E-1408	Dayton/Batco 04306 Dana/Spicer 291318 Trailmobile 381408 Standard Forge 403112 Wagner 921040 Sirco B8697 Haldex C67804 Leland L1719 Meritor R627001	3-1/2"	1-17/32"	1/16"	For 12-1/4" Dia. Brakes
---------------	---	--------	----------	-------	-------------------------

CAMSHAFT WASHERS

EUCLID NO.	REPLACES	O.D.	I.D.	THICK	APPLICATION INFORMATION
------------	----------	------	------	-------	-------------------------



E-656	Dayton/Batco 04300				For 1-1/2" dia. Camshafts. Can be used on Fruehauf Camshafts by reversing
	Eaton 101964				
	Dana/Spicer 11009				
	Meritor 1229E837				
	Meritor 1229G1463				
	Trailmobile 19118				
	Fruehauf 219148				
	Fruehauf 219158				
	Dana/Spicer 291310				
	Dana/Spicer 291341				
	Eaton 3-2179				
	Trailmobile 37081	3-7/8"	1-1/2"	1/16"	
	Trailmobile 38656				
	Standard Forge 403108				
	Haldex 65340				
	Trailmobile 7-9-1				
	Trailmobile 700796				
	Wagner 921056				
	Eaton B12121				
	Sirco B8608				
Haldex C65340					
Leland L202					
Leland L2926					
Dana/Spicer M10HN152					



E-9073	Dayton/Batco 04359				For 16-1/2" Q Plus™ Brakes
	Meritor 1229A4135				
	Sirco B961	3-7/8"	1-5/8"	1/16"	
	Haldex C63166				
	Leland L2945				

CAMSHAFT LOCK RINGS

EUCLID NO.	REPLACES	I.D.	THICK	APPLICATION INFORMATION
------------	----------	------	-------	-------------------------



E-3234	Dayton/Batco 04319			For Eaton Camshafts
	Eaton 100138			
	Dana/Spicer 291303			
	Eaton 3-2174			
	Dana/Spicer 3607			
	Trailmobile 383234			
	Eaton 804017			
	Wagner 921063			
	Sirco B8722			
	Haldex C67457			
Leland L1606				
Meritor R627012				

E-10776		13/16"	3/64"	Retaining Ring
----------------	--	--------	-------	----------------



E-9076	Dayton/Batco 04356			15" x 4" "Q" and 16-1/2" "P" Brakes
	Meritor 1229J4092			
	Sirco B793A	31/32"	3/32"	
	Sirco B794			
	Haldex C63146			
Leland L2940				
E-2734	Dana/Spicer 291314			For Wagner Front Axle Brake. Available only in Camshaft Repair Kit E-3353A
	Haldex 66900			
	Wagner F31921	1-1/8"	1/32"	
	Meritor R627039			

CAMSHAFT LOCK RINGS

EUCLID NO.	REPLACES	I.D.	THICK	APPLICATION INFORMATION
E-801	Dayton/Batco 01482	1-1/8"	1/16"	Lock Ring. For Meritor 4000-6000 Series Axles. Also used on 1-1/4" Anchor Pins with grooves.
	Meritor 1229X1116			
	Eaton 2-2137			
	Standard Forge 214100			
	Eaton 2807929			
	Dana/Spicer 31624			
	Navistar 3212934R			
	Dana/Spicer 341525			
	Trailmobile 38801			
	Haldex 65358			
	Trailmobile 700728			
	Eaton 820007			
	Eaton 86596			
	Wagner 914040			
	Eaton B1214			
Sirco B793				
Haldex C65358				
Wagner FC031961				
Navistar IT341525				
Leland L397				
E-5093	Dayton/Batco 01492	1-5/32"	3/32"	15" x 3-1/2" x 4" "T" Brakes. 16-1/2" "Q" Brakes.
	Dayton/Batco 04492			
	Meritor 1229D2942			
	Eaton 32144			
	Dana/Spicer 341547			
	Haldex 65423			
	Sirco B669			
	Sirco B8689			
Haldex C66698				
Leland L331				
E-2720	Dana/Spicer 291306	1-5/16"	1/16"	For Wagner Drive Axle Brake
	Haldex 66892			
	Sirco B795			
	Wagner F31955			
	Wagner FC031955			
Meritor R627027				
E-4736	Dayton/Batco 04318	1-3/8"	3/32"	Wider snap ring for use with Meritor Drive Axle Camshafts. Not for use with Euclid Replacement Camshafts.
	Meritor 1229Q2851			
	Dana/Spicer 341563			
	Trailmobile 384736			
	Sirco B8691			
	Haldex C65700			
Leland L2900				



CAMSHAFT LOCK RINGS

EUCLID NO. REPLACES I.D. THICK APPLICATION INFORMATION

E-526	Dayton/Batco 04310	1-31/64"	1/16"	For All 1-1/2" Dia. Camshafts
	Eaton 104521			
	Meritor 1229H866			
	Meritor 1229Z1118			
	Trailmobile 17186			
	GMC 2101124			
	Fruehauf 219160			
	Holland Hitch 219160X			
	Dana/Spicer 291301			
	Eaton 3-2186			
	Trailmobile 38526			
	Haldex 65318			
	Navistar 69339R1			
	Trailmobile 700738			
	Trailmobile 7334			
	Eaton 820095			
	Navistar 88119R1			
	Wagner 921060			
	Eaton B1716			
	Sirco B8604			
Sirco BB604				
Haldex C65318				
Navistar IT291301				
Leland L137				



E-1569	Dayton/Batco 04315	1-1/2"	1/16"	For Meritor 4000-6000 Series Axle and "Pro-Par" Axle with 1-5/8" Dia. Camshaft
	Eaton 104886			
	Meritor 1229A1119			
	Meritor 1229D3124			
	Dana/Spicer 291302			
	Eaton 3-2187			
	Trailmobile 381569			
	Haldex 65379			
	Trailmobile 700772			
	Wagner 921061			
	Fruehauf AXA000418001			
	Holland Hitch AXA0418			
	Holland Hitch AXA04181			
	Sirco B8622			
	Haldex C65379			
	Navistar IT291302			
Leland L897				
Meritor R627017				

E-910	Dayton/Batco 04314	1-1/2"	1/16"	For 1-1/2" Dia. Camshaft. Use in Cam Front Lock Groove
	Dayton/Batco 04317			
	Standard Forge 21404			
	Dana/Spicer 291305			
	Dana/Spicer 291315			
	Eaton 298099			
	Eaton 3-2716			
	Dana/Spicer 38038			
	Haldex 65452			
	Trailmobile 7007180			
	Eaton 820008			
	Wagner 921062			
	Eaton B1215			
	Sirco B8634			
	Haldex C65452			
	Leland L467			
Meritor R627014				
Meritor R627016				



MANUAL SLACK ADJUSTERS



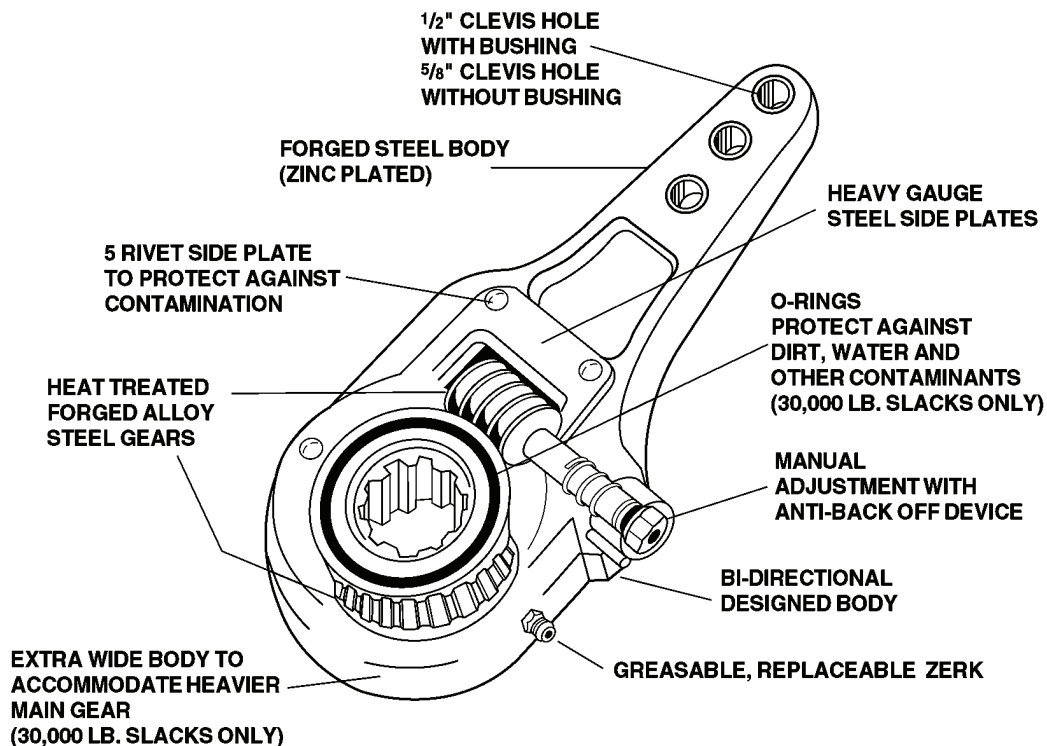



Listed by Cam Spline Size



EUCLID NO.	TYPE	REPLACES	FITS CAM SPLINE	ARM LENGTH	APPLICATION & GENERAL INFORMATION
E-4904S		Dana/Spicer 10399 Bendix 278302 Haldex KN48031	1-1/4"-10		For All 1-1/4" -10 Spline Camshafts
E-9104	LH			4-1/2" - 5-1/2"	5/8" Offset Arm for Meritor 15" x 4" "Q" Brake.
E-9103	RH				
E-9102		Haldex KN55001	1-1/4"-24	5-1/2"	For Meritor 15" x 4" "Q" Brake.
E-1116	LH	Dana/Spicer 10357 Bendix 278106 Bendix 288542		5" - 6"	1-1/2" Offset Arm.
E-1115	RH	Dana/Spicer 10356 Bendix 278105 Bendix 288541	1-1/2"-10		
E-612HD		Dana/Spicer 10351 Bendix 224293 Bendix 286965 Haldex 18500		5" - 6" - 7"	
E-612S-BK		Dana/Spicer 10351 Bendix 278312 Bendix 278323 Haldex KN47001			

MANUAL SLACK ADJUSTERS

Listed by Cam Spline Size

EUCLID NO.	TYPE	REPLACES	FITS CAM SPLINE	ARM LENGTH	APPLICATION & GENERAL INFORMATION
	E-940HD	Meritor R823001			
	E-940S-BK	Dana/Spicer 10354 Bendix 277959 Haldex KN47011		5-1/2" - 6-1/2"	
	E-6113	Bendix 278008 Bendix 278016 Haldex KN47012			Same as E-940 except has 5/8" Bushed Clevis Hole.
	E-2091	Dana/Spicer 10353 Bendix 278084 Haldex KN51000		6"	Curved Arm for 12-1/4" Brakes.
	E-2458HD	Bendix 101207 Bendix 101215 Dana/Spicer 10355HD Haldex 18531	1-1/2"-28	5" - 6" - 7"	
	E-2458S-BK	Bendix 103345 Dana/Spicer 10355 Haldex KN44051			
	E-2459HD	Bendix 101214 Dana/Spicer 10368HD Haldex 44061			
	E-2459S-BK	Bendix 288753 Dana/Spicer 10368 Haldex KN44061		5-1/2" - 6-1/2"	
	E-6109	LH Dana/Spicer 10384 Haldex KN53010		6" - 7"	5/8" Offset Arm.
	E-6110	RH Dana/Spicer 10383 Haldex KN53000			
	E-9105	Haldex KN52060	1-1/2"-48	4" - 5"	
	E-9106		1-5/8"-37	5-1/2"	
	E-1574HD	Dana/Spicer 10367 Haldex 18535 Haldex 18536		6"	
	E-1574S-BK				

CLEVIS PIN BUSHING



EUCLID NO.	TYPE	REPLACES	FITS CAM SPLINE	ARM LENGTH	APPLICATION & GENERAL INFORMATION
E-2307		5/8"	1/2"	31/64"	

Visit us today at
XpresswayPlus.com



to place your order!

FEATURES AND BENEFITS

A. ASA Housing

- Flexible design options provide improved packaging:
 - "Handed" and "unhanded" versions fit various packaging requirements (unhanded version shown).
 - Lightest weight automatic slack adjuster in the market.

B. Piston

- Various pistons to adapt to unique vehicle vocations and duty cycles.

C. Boot

- Press-in and sealed for maximum durability.

D. Pull Pawl

- Design eliminates the need to remove pawl for manual brake adjustment.
- Built-in safety feature so brake cannot inadvertently be backed-off.

E. Worm Gear

- Buttress type provides increased strength for longer life.
 - Lubrication hole and groove provide lubrication to splines, helping eliminate corrosion and seizing up, and resulting in easier servicing.

F. Gear Face Seals

- Help decrease internal contamination and corrosion, minimizing internal torques.
 - Eliminates sensitivity to external road debris, etc., resulting in reduced internal torques.

G. Worm Seal

- Worm seal prevents water gaining access to worm gear shaft.

H. Manual Adjusting Nut

- As a safety precaution, manual adjusting nut cannot be inadvertently backed-off.

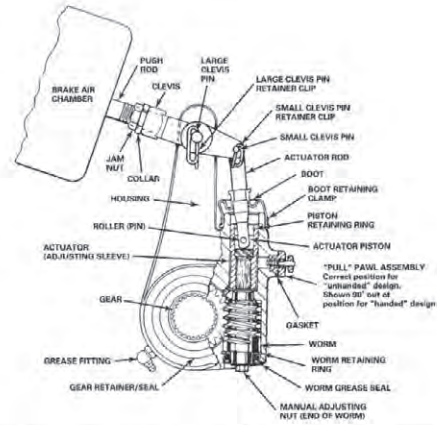

How the Meritor Automatic Slack Adjusters Work:

When the brakes are first actuated...

- The air chamber pushrod moves beyond the predetermined optimum stroke length.
- The change in geometry between the chamber pushrod and slack lever arm raises the slack adjuster actuator rod.
- the piston contacts the retaining ring which lifts the actuator.
- The actuator has spiral serrations on it which jump over the serration on the pawl, only if the adjustment is required.
- The components remain in the position until the start of the return stroke.



The Adjustment Phase

- The returning movement of the air chamber pushrod and slack lever arm on the brake release, forces the ASA piston and then the actuator downward.
- Contact between the pawl and actuator teeth cause the actuator to rotate.
- The rotation of the actuator in its downward travel causes the worm to rotate.
- The rotation of the worm causes the gear to rotate.
- The gear rotates the camshaft (cam brake) or powershaft (air disc brake) so that proper brake adjustment is maintained.

MERITOR AUTOMATIC SLACK ADJUSTERS

(MOST POPULAR/CLEVISSED NUMBERS)



UNHANDLED



TYPE A



TYPE B

EUCLID NO.	MERITOR CLEVISSED NO.	TYPE	SPLINE SIZE	LEVER LENGTH	CLEVIS THREAD	FOR CHAMBER
E-11395	R801001	unhandled	1-1/4"-10	5-1/2"	1/2"-20 str	16
E-11396	R801002	unhandled	1-1/4"-24	5-1/2"	1/2"-20 str	16
E-11397	R801003	unhandled	1-1/4"-24	5-1/2"	5/8"-18 str	16, 20
E-11398	R801041	unhandled	1-1/2"-10	5-1/2"	5/8"-18 str	24, 30
E-11399	R801042	unhandled	1-1/2"-10	6"	5/8"-18 str	30
E-11400	R801072	unhandled	1-1/2"-28	5-1/2"	5/8"-18 str	20, 24, 36 drum
E-11401	R801073	unhandled	1-1/2"-28	5-1/2"	5/8"-18 str	24, 30
E-11402	R801074	unhandled	1-1/2"-28	6"	5/8"-18 str	30
E-11404	R801079	unhandled	1-1/2"-28	5-1/2"	5/8"-18 str	16, 20
E-11405	R801101	unhandled	1-5/8"-37	5-1/2"	5/8"-18 str	24, 30
E-11406	R801102	unhandled	1-5/8"-37	6"	5/8"-18 str	30
E-11407	R802070	TYPE A	1-1/4"-24	5-1/2"	5/8"-18 str	20
E-11408	R802071	TYPE B	1-1/4"-24	5-1/2"	5/8"-18 str	20
E-11409	R802316	TYPE A	1-1/2"-10	5-1/2"	5/8"-18 str	24, 30
E-11410	R802317	TYPE B	1-1/2"-10	5-1/2"	5/8"-18 str	24, 30
E-11411	R802332	TYPE A	1-1/2"-10	5-1/2"	5/8"-18 str	36
E-11412	R802333	TYPE B	1-1/2"-10	5-1/2"	5/8"-18 str	36
E-11413	R802380	TYPE A	1-1/2"-10	7"	3/4"-16 str	30 drum
E-11414	R802381	TYPE B	1-1/2"-10	7"	3/4"-16 str	30 drum
E-11415	R802444	TYPE A	1-1/2"-28	5-1/2"	5/8"-18 str	20, 24 disc, 36 drum
E-11416	R802445	TYPE B	1-1/2"-28	5-1/2"	5/8"-18 str	20, 24 disc, 36 drum
E-11417	R802446	TYPE A	1-1/2"-28	5-1/2"	5/8"-18 str	24, 30
E-11418	R802447	TYPE B	1-1/2"-28	5-1/2"	5/8"-18 str	24, 30
E-11419	R802462	TYPE B	1-1/2"-28	5-1/2"	5/8"-18 str	30 disc
E-11420	R802463	TYPE A	1-1/2"-28	5-1/2"	5/8"-18 str	30 disc
E-11421	R802486	TYPE A	1-1/2"-28	6"	5/8"-18 str	30
E-11422	R802487	TYPE B	1-1/2"-28	6"	5/8"-18 str	30
E-11423	R802490	TYPE A	1-1/2"-28	6"	5/8"-18 str	36
E-11424	R802491	TYPE B	1-1/2"-28	6"	5/8"-18 str	36
E-11403	R802512	TYPE A	1-1/2"-28	6-1/2"	5/8"-18 str	36
E-11902	R802513	TYPE B	1-1/2"-28	6-1/2"	5/8"-18 str	36
E-11425 ¹	R802666	TYPE A	1-1/2"-10	5-1/2"	5/8"-18 str	36
E-11426 ¹	R802667	TYPE B	1-1/2"-10	5-1/2"	5/8"-18 str	36

NOTE: The Slack Adjuster must be installed so the pawl can be removed during maintenance.

¹ Special grease fitting location.

MERITOR MISC AUTOMATIC SLACK ADJUSTER PARTS



EUCLID NO.	MERITOR NO.	THREAD SIZE	CLEVIS TYPE	APPLICATION INFORMATION
E-11427A	R810024	1/2"-20	Offset	For standard type 16 chambers. Clevis kit includes Lightweight Clevis, pins and clips.
E-11899	R810022	1/2"-20	Offset	For long stroke type 16 chambers. Clevis kit includes Lightweight Clevis, pins and clips.
E-11429A	R810025	5/8"-18	Offset	For standard type 20, 24, 30, 36 chambers. Clevis kit includes Lightweight Clevis, pins and clips.
E-11901	R810023	5/8"-18	Offset	For long stroke type 20, 24, 30, 36 chambers. Clevis kit includes Lightweight Clevis, pins and clips.
E-11428A	R810018	1/2"-20	Straight	1-3/8" CL-CL of pins. For standard type 16 chambers. Clevis kit includes Lightweight Clevis, pins and clips.
E-11898	R810020	1/2"-20	Straight	For long stroke type 16 chambers. Clevis kit includes Lightweight Clevis, pins and clips.
E-11430A	R810019	5/8"-18	Straight	1-3/8" CL-CL of pins. For standard type 20, 24, 30, 36 chambers. Clevis kit includes Lightweight Clevis, pins and clips.
E-11900	R810021	5/8"-18	Straight	For long stroke type 20, 24, 30, 36 chambers. Clevis kit includes Lightweight Clevis, pins and clips.



EUCLID NO.	MERITOR NO.	DESCRIPTION	APPLICATION INFORMATION
E-11432	R801700	Pawl Kit	For All Meritor ASAs

EUCLID/HALDEX SELF-ADJUSTING BRAKE ADJUSTERS

STEERING AXLE (NON-DRIVE) APPLICATIONS FOR 15", 16-1/4" AND 16-1/2" BRAKES



EUCLID KIT NO.	INCLUDES BRACKET NO.	ANGLE	STRAIGHT/OFFSET	SPLINE SIZE	ARM LENGTH	BUSHING I.D.	APPLICATION
E-6900A	E-6983	0°	Straight	1-1/4"-10	5-1/2"	1/2"-5/8"	Double Bend Control Arm. Standard Steering Axle Brakes. Replaces 400-10001
E-6902A	E-6984	0°	Straight	1-1/4"-24	5-1/2"	1/2"-5/8"	Double Bend Control Arm. Standard Steering Axle Brakes. Replaces 400-10004
E-6903A	E-6983	0°	Straight	1-1/2"-10	5-1/2"	1/2"-5/8"	Double Bend Control Arm. Standard Steering Axle Brakes. Replaces 400-10005
E-6905A	E-6983	0°	Straight	1-1/2"-28	5-1/2"	1/2"-5/8"	Double Bend Control Arm. Standard Steering Axle Brakes. Replaces 400-10008



E-6951A	E-6985	16°	Straight	1-1/2"-28	5-1/2"	1/2"	For Meritor Air Disc Brake. Replaces 400-10402
---------	--------	-----	----------	-----------	--------	------	--



E-6906A	E-6983	22°	LH 5/8"	1-1/4"-10	5-1/2"	1/2"-5/8"	Double Bend Control Arm. For Standard Steering Axle Brakes with 5/8" Offset Arm. Replaces 400-10003
E-6907A	E-6983	22°	RH 5/8"	1-1/4"-10	5-1/2"	1/2"-5/8"	Double Bend Control Arm. For Standard Steering Axle Brakes with 5/8" Offset Arm. Replaces 400-10002
E-6981	E-6984	22°	LH 5/8"	1-1/4"-24	5-1/2"	1/2"-5/8"	Double Bend Control Arm. For Standard Steering Axle Brakes with 5/8" Offset Arm. Replaces 400-10041
E-6982	E-6984	22°	RH 5/8"	1-1/4"-24	5-1/2"	1/2"-5/8"	Double Bend Control Arm. For Standard Steering Axle Brakes with 5/8" Offset Arm. Replaces 400-10040



E-6910	E-6956	22°	RH 1-1/2"	1-1/2"-10	5-1/2"	1/2"	For Mack 16,000 lb.-Up Steering Axle Brakes with 1-1/2" Offset Arm. Replaces 400-10030
E-6911	E-6956	22°	LH 1-1/2"	1-1/2"-10	5-1/2"	1/2"	For Mack 16,000 lb.-Up Steering Axle Brakes with 1-1/2" Offset Arm. Replaces 400-10031
E-6912	E-6956	22°	RH 1-1/2"	1-1/2"-28	5-1/2"	1/2"-5/8"	For Mack 16,000 lb.-Up Steering Axle Brakes with 1-1/2" Offset Arm. Replaces 400-10009
E-6913	E-6956	22°	LH 1-1/2"	1-1/2"-28	5-1/2"	1/2"-5/8"	For Mack 16,000 lb.-Up Steering Axle Brakes with 1-1/2" Offset Arm. Replaces 400-10010

CAUTION: Do not mix Automatic Slack Adjuster brands on the same vehicle.

EUCLID/HALDEX SELF-ADJUSTING BRAKE ADJUSTERS

DRIVE AXLE APPLICATIONS FOR 16-1/2" AND 18" BRAKES



EUCLID KIT NO.	INCLUDES BRKT NO.	ANGLE	STRAIGHT/OFFSET	SPLINE SIZE	ARM LENGTH	BUSHING I.D.	APPLICATION
E-10892	E-10894		Straight	1-1/2"-10	5-1/2"	1/2"	Kenworth with 8 Bag Air Ride to avoid interference with air bag supports. Replaces 400-10155
E-10893	E-10894		Straight	1-1/2"-28	5-1/2"	1/2"	Kenworth with 8 Bag Air Ride to avoid interference with air bag supports. Replaces 400-10156



E-6914A	E-6983	16°	Straight	1-1/2"-10	6"	1/2"	Double Bend Control Arm. For Mack Drive Axle Brakes. Replaces 400-10145
E-6918A	E-6983	16°	Straight	1-1/2"-28	6"	1/2"	Double Bend Control Arm. For Mack Drive Axle Brakes. Replaces 400-10144
E-6919A	E-6983	16°	Straight	1-1/2"-28	5-1/2" - 6-1/2"	1/2"	Double Bend Control Arm. For Mack Drive Axle Brakes. Replaces 400-10146

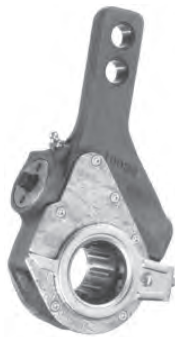

E-6951A	E-6985	16°	Straight	1-1/2"-28	5-1/2"	1/2"	For Meritor Air Disc Brake. Replaces 400-10402
E-6924B	E-10262	34°	Straight	1-1/2"-10	5-1/2" - 6-1/2"	1/2"-5/8"	For Standard Drive Axle Brakes. Replaces 400-10143
E-6923B	E-10262	34°	Straight	1-1/2"-10	5" - 6"	1/2"-5/8"	For Standard Drive Axle Brakes. Replaces 400-10142
E-6925B	E-10262	34°	Straight	1-1/2"-28	5" - 6"	1/2"-5/8"	For Standard Drive Axle Brakes. Replaces 400-10140
E-6927B	E-10262	34°	Straight	1-1/2"-28	5-1/2" - 6-1/2"	1/2"-5/8"	For Standard Drive Axle Brakes. Replaces 400-10141

TRAILER AXLE APPLICATIONS FOR 12-1/4" BRAKES



EUCLID KIT NO.	INCLUDES BRACKET NO.	ANGLE	STRAIGHT/OFFSET	SPLINE SIZE	ARM LENGTH	BUSHING I.D.	APPLICATION
E-6928	E-6967A	35°	Straight	1-1/2"-10	6"	1/2"	Double Bend Control Arm. For Meritor, Eaton, Spicer (Dana) and Standard Forge with 4-Hole Cam Bracket. Improved, Longer Life Bushing and Flat Anchor Pin. Replaces 400-10306
E-6933	E-6967A	35°	Straight	1-1/2"-28	6"	1/2"	Double Bend Control Arm. For Meritor, Eaton, Spicer (Dana) and Standard Forge with 4-Hole Cam Bracket. Improved, Longer Life Bushing and Flat Anchor Pin. Replaces 400-10305

CAUTION: Do not mix Automatic Slack Adjuster brands on the same vehicle.

EUCLID/HALDEX SELF-ADJUSTING BRAKE ADJUSTERS

TRAILER AXLE APPLICATIONS FOR 12-1/4" BRAKES



EUCLID KIT NO.	INCLUDES BRACKET NO.	ANGLE	STRAIGHT/OFFSET	SPLINE SIZE	ARM LENGTH	BUSHING I.D.	APPLICATION
E-6932	E-6967A	35°	Straight	1-1/2"-28	5-1/2"	1/2"	Double Bend Control Arm. For Meritor, Eaton, Spicer (Dana) and Standard Forge with 4-Hole Cam Bracket. Improved, Longer Life Bushing and Flat Anchor Pin. Replaces 400-10304
E-6934	E-6966A	35°	Straight	1-5/8"-37	6"	1/2"	Double Bend Control Arm. For Fruehauf with New Style 4-Hole Cam Bracket. Improved, Longer Life Bushing and Flat Anchor Pin. Replaces 400-10307

TRAILER AXLE APPLICATIONS FOR 16-1/2" BRAKES



EUCLID KIT NO.	INCLUDES BRACKET NO.	ANGLE	STRAIGHT/OFFSET	SPLINE SIZE	ARM LENGTH	BUSHING I.D.	APPLICATION
E-6940	E-6967A	0°	Straight	1-1/2"-10	5-1/2"	1/2"	Double Bend Control Arm. For Meritor, Eaton, Standard Forge with 4-Hole Cam Bracket. Improved, Longer Life Bushing and Flat Anchor Pin. Replaces 400-10215
E-6936	E-6967A	0°	Straight	1-1/2"-10	6"	1/2"	Double Bend Control Arm. For Meritor, Eaton, Standard Forge with 4-Hole Cam Bracket. Improved, Longer Life Bushing and Flat Anchor Pin. Replaces 400-10216
E-6944	E-6967A	0°	Straight	1-1/2"-28	5-1/2"	1/2"	Double Bend Control Arm. For Meritor, Eaton, Standard Forge with 4-Hole Cam Bracket. Improved, Longer Life Bushing and Flat Anchor Pin. Replaces 400-10211
E-6942	E-6967A	0°	Straight	1-1/2"-28	6"	1/2"	Double Bend Control Arm. For Meritor, Eaton, Standard Forge with 4-Hole Cam Bracket. Improved, Longer Life Bushing and Flat Anchor Pin. Replaces 400-10212
E-6947	E-6966A	0°	Straight	1-5/8"-37	5-1/2"	1/2"	Double Bend Control Arm. For Fruehauf with New Style 4-Hole Cam Bracket. Improved, Longer Life Bushing and Flat Anchor Pin. Replaces 400-10213
E-6946	E-6966A	0°	Straight	1-5/8"-37	6"	1/2"	Double Bend Control Arm. For Fruehauf with New Style 4-Hole Cam Bracket. Improved, Longer Life Bushing and Flat Anchor Pin. Replaces 400-10214

CAUTION: Do not mix Automatic Slack Adjuster brands on the same vehicle.

EUCLID/HALDEX SELF-SETTING ADJUSTING BRAKE ADJUSTERS

TRAILER AXLE APPLICATIONS FOR 16-1/2" BRAKES



EUCLID KIT NO.	INCLUDES BRACKET NO.	ANGLE	STRAIGHT/OFFSET	SPLINE SIZE	ARM LENGTH	BUSHING I.D.	APPLICATION
E-11925	E-6967A	0°	Straight	1-1/2"-10	5-1/2"	1/2"	Double Bend Control Arm. For Meritor, Eaton, Standard Forge with 4-Hole Cam Bracket. Improved, Longer Life Bushing and Flat Anchor Pin. Replaces 400-20215
E-11926	E-6967A	0°	Straight	1-1/2"-10	6"	1/2"	Double Bend Control Arm. For Meritor, Eaton, Standard Forge with 4-Hole Cam Bracket. Improved, Longer Life Bushing and Flat Anchor Pin. Replaces 400-20216
E-11921	E-6967A	0°	Straight	1-1/2"-28	5-1/2"	1/2"	Double Bend Control Arm. For Meritor, Eaton, Standard Forge with 4-Hole Cam Bracket. Improved, Longer Life Bushing and Flat Anchor Pin. Replaces 400-20211
E-11922	E-6967A	0°	Straight	1-1/2"-28	6"	1/2"	Double Bend Control Arm. For Meritor, Eaton, Standard Forge with 4-Hole Cam Bracket. Improved, Longer Life Bushing and Flat Anchor Pin. Replaces 400-20212
E-11923	E-6966A	0°	Straight	1-5/8"-37	5-1/2"	1/2"	Double Bend Control Arm. For Fruehauf with New Style 4-Hole Cam Bracket. Improved, Longer Life Bushing and Flat Anchor Pin. Replaces 400-20213
E-11924	E-6966A	0°	Straight	1-5/8"-37	6"	1/2"	Double Bend Control Arm. For Fruehauf with New Style 4-Hole Cam Bracket. Improved, Longer Life Bushing and Flat Anchor Pin. Replaces 400-20214

CAUTION: Do not mix Automatic Slack Adjuster brands on the same vehicle.

EUCLID/HALDEX BRAKE ADJUSTER HARDWARE



EUCLID NO.	REPLACES	APPLICATION & GENERAL INFORMATION
E-427K	Haldex 42710558	Includes 4 Cap Nuts, 4 Anchor Pins, 4 Bushings, Includes long life bushing and redesigned flat anchor pin.
E-452A	Haldex 452-10125	Long life control arm bushing for flat anchor pin.





EUCLID/HALDEX BRAKE ADJUSTER BRACKET KITS



EUCLID BRACKET NO.	USED IN SLACK KIT NO.	APPLICATION
E-10262	E-6923B, E-6924B, E-6925B, E-6927B	Drive axle. Angled 1-1/4" x 7" strap. Replaces 427-10553
E-6985	E-6923A, E-6924A, E-6925A, E-6927A, E-6951A	Drive axle and air disc brake applications. Replaces 427-10543
E-10894	E-10892, E-10893	1-1/4" x 4-3/4" strap. For use with Kenworth 8 air bag drive axle brakes. Replaces 427-10554

CAUTION: Do not mix Automatic Slack Adjuster brands on the same vehicle.





EUCLID/HALDEX BRAKE ADJUSTER BRACKET KITS



	EUCLID BRACKET NO.	USED IN SLACK KIT NO.	APPLICATION
	E-6956	E-6912, E-6913	Mack 16,000 lb. and up steer axle applications. Replaces 427-10548
	E-6966A	E-6934, E-6946, E-6947, E-11923, E-11924	12-1/4" and 16-1/2" Fruehauf trailer axle applications with 4-hole camshaft support bracket. Includes new flat anchor pin and re-designed, longer life bushing. Replaces 427-10562
	E-6967A	E-6928, E-6932, E-6933, E-6936, E-6940, E-6942, E-6944, E-11921, E-11922, E-11925, E-11926	12-1/4" and 16-1/2" Meritor, Eaton, Spicer (Dana) and Standard Forge trailer axle applications with 4-hole camshaft support bracket. Includes new flat anchor pin and re-designed, longer life bushing. Replaces 427-10565
	E-6983	E-6900A, E-6903A, E-6905A, E-6906A, E-6907A, E-6914A, E-6918A, E-6919A	Mack drive axle applications. Replaces 427-10566, Steer axle applications with 2-1/2" O.D. camshaft support tube. Replaces 427-10562
	E-6984	E-6902A, E-6981, E-6982	Steer axle applications with 2" O.D. camshaft support tube. Replaces 427-10567

CAUTION: Do not mix Automatic Slack Adjuster brands on the same vehicle.

MERITOR CLEARANCE SENSING AUTOMATIC SLACK ADJUSTERS

DRIVE AXLE APPLICATIONS FOR 16-1/2" AND 18" BRAKES

	EUCLID PART NO.	BRACKET NO.	ANGLE	STRAIGHT/ OFFSET	SPLINE SIZE	ARM LENGTH	BUSHING I.D.	APPLICATION
	R806002	R810306	0°	Straight	1-1/2"10	5-1/2"	5/8"	Single Bend Control Arm. For Kenworth with 8 bag air ride to avoid interference with air bag supports. Replaces 400-10155, 409-10635
	R806003	R810306	0°	Straight	1-1/2"28	5-1/2"	5/8"	Single Bend Control Arm. For Kenworth with 8 bag air ride to avoid interference with air bag supports. Replaces 400-10156, 409-10648
	R806018	R810302	16°	Straight	1-1/2"10	6"	1/2"	Double Bend Control Arm. For Mack drive axle brakes. Replaces 400-10145, 409-10680
	R806017	R810302	16°	Straight	1-1/2"28	5-1/2", 6-1/2"	1/2"	Double Bend Control Arm. For Mack drive axle brakes. Replaces 400-10146, 409-10679
	R806016	R810302	16°	Straight	1-1/2"28	6"	1/2"	Double Bend Control Arm. For Mack drive axle brakes. Replaces 400-10144, 409-10678
	R806001	R810305	16°	Straight	1-1/2"28	5-1/2"	1/2"	Single Bend Control Arm. For Meritor air disc brakes. Replaces 400-10402, 409-10584
	R806023	R810300	34°	Straight	1-1/2"10	5", 6"	5/8"	Single Bend Control Arm. For standard drive axle brakes. Replaces 400-10142, 409-10741
	R806022	R810300	34°	Straight	1-1/2"10	5-1/2", 6-1/2"	5/8"	Single Bend Control Arm. For standard drive axle brakes. Replaces 400-10143, 409-10733
	R806024	R810300	34°	Straight	1-1/2"28	5", 6"	5/8"	Single Bend Control Arm. For standard drive axle brakes. Replaces 400-10140, 409-10742
	R806004	R810300	34°	Straight	1-1/2"28	5-1/2"	5/8"	Single Bend Control Arm. For standard drive axle brakes. Replaces 400-10141, 409-10650
	R806026	R810300	34°	Straight	1-1/2"28	5-1/2", 6-1/2"	5/8"	Single Bend Control Arm. For standard drive axle brakes. Replaces 400-10141, 409-10653

	EUCLID PART NO.	BRACKET NO.	ANGLE	STRAIGHT/OFFSET	SPLINE SIZE	ARM LENGTH	BUSHING I.D.	APPLICATION
	R806009	R810302	0°	Straight	1-1/4"10	5-1/2"	5/8"	Double Bend Control Arm. For standrad steer axle brakes. Replaces 400-10001, 409-10658
	R806010	R810303	0°	Straight	1-1/4"24	5-1/2"	5/8"	Double Bend Control Arm. For standrad steer axle brakes. Replaces 400-10004, 409-10659
	R806011	R810302	0°	Straight	1-1/2"10	5-1/2"	5/8"	Double Bend Control Arm. For standrad steer axle brakes. Replaces 400-10005, 409-10662
	R806012	R810302	0°	Straight	1-1/2"28	5-1/2"	5/8"	Double Bend Control Arm. For standrad steer axle brakes. Replaces 400-10008, 409-10663
	R806025	R810310	0°	Straight	1-1/2"28	5-1/2"	1/2"	Single Bend Control Arm. For standard steer axle brakes. Replaces 400-10081, 409-10228
	R806502	R810302	22°	Offset LH 5/8"	1-1/4"10	5-1/2"	5/8"	Double Bend Control Arm. For standard steer axle brakes with 5/8" offset arm. Replaces 400-10003, 409-10660
	R806503	R810302	22°	Offset RH 5/8"	1-1/4"10	5-1/2"	5/8"	Double Bend Control Arm. For standard steer axle brakes with 5/8" offset arm. Replaces 400-10002, 409-10661
	R806504	R810303	22°	Offset LH 5/8"	1-1/4"24	5-1/2"	5/8"	Double Bend Control Arm. For standard steer axle brakes with 5/8" offset arm. Replaces 400-10041, 409-10664
	R806505	R810303	22°	Offset RH 5/8"	1-1/4"24	5-1/2"	5/8"	Double Bend Control Arm. For standard steer axle brakes with 5/8" offset arm. Replaces 400-10040, 409-10665
	R806500	R810304	22°	Offset RH 1-1/2"	1-1/2"28	5-1/2"	1/2"	Single Bend Control Arm. For Mack 16,000 lb.+ steer axle brakes with 1-1/2" offset arm. Replaces 400-10058, 409-10599
	R806501	R801304	22°	Offset LH 1-1/2"	1-1/2"28	5-1/2"	1/2"	Single Bend Control Arm. For Mack 16,000 lb.+ steer axle brakes with 1-1/2" offset arm. Replaces 400-10059, 409-10600

MERITOR CLEARANCE SENSING AUTOMATIC SLACK ADJUSTERS

STEER AXLE (NON-DRIVE) APPLICATIONS FOR 15", 16-1/4" AND 16-1/2" BRAKES



EUCLID PART NO.	BRACKET NO.	ANGLE	STRAIGHT/OFFSET	SPLINE SIZE	ARM LENGTH	BUSHING I.D.	APPLICATION
R806507	R810311	22°	Offset LH 5/8"	1-1/2"28	6"	1/2"	Single Bend Control Arm. For Dina Bus and MCI steer axle brakes. Replaces 400-10068, 409-10638
R806508	R810314	22°	Offset RH 5/8"	1-1/2"28	6"	1/2"	Single Bend Control Arm. For Dina Bus and MCI steer axle brakes. Replaces 400-10069, 409-10639

TRAILER AXLE APPLICATIONS FOR 12-1/4" BRAKES



EUCLID PART NO.	BRACKET NO.	ANGLE	STRAIGHT/OFFSET	SPLINE SIZE	ARM LENGTH	BUSHING I.D.	APPLICATION
R806000	R810307	34°	Straight	1-1/2"10	5"	1/2"	Single Bend Control Arm. For Delvan trailer axle brakes. Replaces 409-10129

R806007	R810301	35°	Straight	1-1/2"10	6"	1/2"	Double Bend Control Arm. For Meritor, Eaton, Spicer (Dana and Standard Forge) trailer axles with 4-hole cam bracket. Replaces 400-10306, 409-10656
---------	---------	-----	----------	----------	----	------	--



R806005	R810301	35°	Straight	1-1/2"28	5-1/2"	1/2"	Double Bend Control Arm. For Meritor, Eaton, Spicer (Dana and Standard Forge) trailer axles with 4-hole cam bracket. Replaces 400-10304, 409-10654
---------	---------	-----	----------	----------	--------	------	--

R806006	R810301	35°	Straight	1-1/2"28	6"	1/2"	Double Bend Control Arm. For Meritor, Eaton, Spicer (Dana and Standard Forge) trailer axles with 4-hole cam bracket. Replaces 400-10305, 409-10655
---------	---------	-----	----------	----------	----	------	--

R806008	R810301	35°	Straight	1-5/8"37	6"	1/2"	Double Bend Control Arm. For Fruehauf trailer axles with 4-hole cam bracket. Replaces 400-10307, 409-10657
---------	---------	-----	----------	----------	----	------	--

TRAILER AXLE APPLICATIONS FOR 16-1/2" BRAKES

EUCLID PART NO.	BRACKET NO.	ANGLE	STRAIGHT/OFFSET	SPLINE SIZE	ARM LENGTH	BUSHING I.D.	APPLICATION
R806021	R810308	0°	Straight	1-1/2"10	5-1/2"	1/2"	Double Bend Control Arm. For standard Meritor, Eaton, Spicer (Dana and Standard Forge) trailer axles. Replaces 400-10215, 409-10685

R806015	R810308	0°	Straight	1-1/2"10	6"	1/2"	Double Bend Control Arm. For Spicer (Dana and Standard Forge) trailer axles with 3-hole cam bracket. Replaces 400-10216, 409-10675
---------	---------	----	----------	----------	----	------	--



R806019	R810301	0°	Straight	1-1/2"28	5-1/2"	1/2"	Double Bend Control Arm. For Meritor, Eaton, Spicer (Dana and Standard Forge) trailer axles with 4-hole cam bracket. Replaces 400-10211, 409-10683
---------	---------	----	----------	----------	--------	------	--







R806013	R810308	0°	Straight	1-1/2"28	6"	1/2"	Double Bend Control Arm. For Meritor, Eaton, Spicer (Dana and Standard Forge) trailer axles with 4-hole cam bracket. Replaces 400-10212, 409-10673
---------	---------	----	----------	----------	----	------	--

R806020	R810301	0°	Straight	1-5/8"37	5-1/2"	1/2"	Double Bend Control Arm. For Fruehauf with 4-hole cam bracket. Replaces 400-10213, 409-10684
---------	---------	----	----------	----------	--------	------	--

R806014	R810301	0°	Straight	1-5/8"37	6"	1/2"	Double Bend Control Arm. For Fruehauf with 4-hole cam bracket. Replaces 400-10214, 409-10674
---------	---------	----	----------	----------	----	------	--







MERITOR CLEARANCE SENSING AUTOMATIC SLACK ADJUSTERS

TRANSIT APPLICATIONS

	EUCLID PART NO.	BRACKET NO.	ANGLE	STRAIGHT/OFFSET	SPLINE SIZE	ARM LENGTH	BUSHING I.D.	APPLICATION
	R806551		0°	Straight	1-1/2"28	5-1/2", 6-1/2"	6-1/4"	Single bend, 65mm. Replaces 4W9035
	R806556		0°	Straight	1-1/2"28	5-1/2"	1/2"	Double bend, 69mm. Replaces 4W9075
	R806549	R810312	0°	Straight	1-1/2"28	5-1/2"	1/2"	Single bend, 60mm. Includes bracket and hardware. Replaces 4W8525
	R806535	R810315	0°	Offset RH 1-1/2"	1-1/2"10	6"	1/2"	Includes bracket and hardware. Replaces 4W9055
	R806536	R810315	0°	Offset LH 1-1/2"	1-1/2"10	6"	1/2"	Includes bracket and hardware. Replaces 4W9060
	R806559	R810315	0°	Offset RH 1-1/2"	1-1/2"28	6"	1/2"	Includes bracket and hardware. Replaces 4W8715
	R806560	R810315	0°	Offset LH 1-1/2"	1-1/2"28	6"	1/2"	Includes bracket and hardware. Replaces 4W8720
	R806548	R810330	0°	Straight	1-1/2"28	5-1/2"	5/8"	Single bend, 65mm. Includes bracket and hardware. Replaces 4W9005
	R806527	R810305	16°	Straight	1-1/2"10	5-1/2"	1/2"	Single bend, 64mm. Includes bracket and hardware. Replaces 4W8535
	R806543	R810305	16°	Straight	1-1/2"28	5-1/2"	1/2"	Single bend, 64mm. Includes bracket and hardware. Replaces 4W8565





MERITOR CLEARANCE SENSING AUTOMATIC SLACK ADJUSTERS

TRANSIT APPLICATIONS

	EUCLID PART NO.	BRACKET NO.	ANGLE	STRAIGHT/OFFSET	SPLINE SIZE	ARM LENGTH	BUSHING I.D.	APPLICATION
	R806525	R810304	23°	Offset LH 1-1/2"	1-1/2"10	5-1/2"	1/2"	Single bend, 60mm. Includes bracket and hardware. Replaces 4W8540
	R806526	R810304	23°	Offset LH 1-1/2"	1-1/2"10	5-1/2"	1/2"	Single bend, 60mm. Includes bracket and hardware. Replaces 4W8545
	R806532	R810312	23°	Offset LH 5/8"	1-1/2"28	5-1/2"	1/2"	Single bend, 60mm. Includes bracket and hardware. Replaces 4W8510
	R806533	R810312	23°	Offset RH 5/8"	1-1/2"28	5-1/2"	1/2"	Single bend, 60mm. Includes bracket and hardware. Replaces 4W8515
	R806528	R810328	23°	Offset LH 5/8"	1-1/2"28	5-1/2"	1/2"	Single bend, 60mm. Includes bracket and hardware. Replaces 4W8620
	R806529	R810328	23°	Offset RH 5/8"	1-1/2"28	5-1/2"	1/2"	Single bend, 60mm. Includes bracket and hardware. Replaces 4W8635
	R806537		28°	Offset RH 1-9/16"	1-1/2"26	5-1/8"	1/2"	Double bend, 66mm. Replaces 4W3265
	R806538		28°	Offset LH 1-9/16"	1-1/2"26	5-1/8"	1/2"	Double bend, 66mm. Replaces 4W3270
	R806545		34°	Offset RH 1-1/2"	1-1/2"10	5-1/2"	1/2"	Single bend, 60mm. Replaces 4W8560
	R806541		34°	Offset LH 1-1/2"	1-1/2"10	6"	1/2"	Single bend, 64mm. Replaces 4W8640
	R806544		34°	Offset LH 1-1/2"	1-1/2"10	6"	1/2"	Replaces 4W9030
	R806552		34°	Straight	1-1/2"10	6"	1/2"	Single bend, 64mm. Replaces 4W9040
	R806554		34°	Offset LH 1-1/2"	1-1/2"10	7"	1/2"	Double bend, 69mm. Replaces 4W8590
	R806555		34°	Offset RH 1-1/2"	1-1/2"10	7"	1/2"	Double bend, 69mm. Replaces 4W8680





MERITOR CLEARANCE SENSING AUTOMATIC SLACK ADJUSTERS

TRANSIT APPLICATIONS

	EUCLID PART NO.	BRACKET NO.	ANGLE	STRAIGHT/OFFSET	SPLINE SIZE	ARM LENGTH	BUSHING I.D.	APPLICATION
	R806547	R810300	34°	Straight	1-1/2"28	6"	1/2"	Includes bracket and hardware. Replaces 4W9015
	R806521	R810309	34°	Offset LH 1-1/2"	1-1/2"10	7"	1/2"	Single bend, 64mm. Includes bracket and hardware. Replaces 4W8500
	R806523	R810309	34°	Straight	1-1/2"10	7"	1/2"	Single bend, 64mm. Includes bracket and hardware. Replaces 4W8645
	R806530	R810315	34°	Offset LH 1-1/2"	1-1/2"10	6"	1/2"	Single bend, 64mm. Includes bracket and hardware. Replaces 4W8600
	R806534	R810312	34°	Straight	1-1/2"28	6-1/2"	1/2"	Single bend, 60mm. Includes bracket and hardware. Replaces 4W8520
	R806531	R810315	34°	Offset RH 1-1/2"	1-1/2"10	6"	1/2"	Single bend, 64mm. Includes bracket and hardware. Replaces 4W8570
	R806539	R810316	34°	Offset LH 1-1/2"	1-1/2"10	7"	1/2"	Single bend, 60mm. Includes bracket and hardware. Replaces 4W8615
	R806540	R810316	34°	Offset RH 1-1/2"	1-1/2"10	7"	1/2"	Single bend, 60mm. Includes bracket and hardware. Replaces 4W8630
	R806542	R810328	34°	Offset RH 1-1/2"	1-1/2"10	6"	1/2"	Single bend, 64mm. Includes bracket and hardware. Replaces 4W8605
	R806546	R810328	34°	Offset LH 1-1/2"	1-1/2"28	5-1/2"	1/2"	Includes bracket and hardware. Replaces 4W9010
	R806550	R810329	34°	Straight	1-1/2"28	6-1/2"	1/2"	Single bend, 64mm. Includes bracket and hardware. Replaces 4W8690
	R806553	R810331	34°	Straight	1-1/2"10	5-1/2"	5/8"	Includes bracket and hardware. Replaces 4W9050
	R806557	R810333	34°	Offset LH 1-1/2"	1-1/2"10	6"	1/2"	Single bend, 65mm. Includes bracket and hardware. Replaces 4W8625
	R806558	R810333	34°	Offset RH 1-1/2"	1-1/2"10	6"	1/2"	Single bend, 65mm. Includes bracket and hardware. Replaces 4W8595
	R806522	R810336	34°	Offset RH 1-1/2"	1-1/2"10	7"	1/2"	Single bend, 64mm. Includes bracket and hardware. Replaces 4W8650
	R806524	R810336	34°	Straight	1-1/2"10	7"	1/2"	Single bend, 64mm. Includes bracket and hardware. Replaces 4W8610
	R806563		120°	Offset RH 5/8"	1-1/2"26	5-1/8"	1/2"	Double bend, 65mm. Replaces 4W3115
	R806564		120°	Offset LH 5/8"	1-1/2"26	5-1/8"	1/2"	Double bend, 65mm. Replaces 4W3120

MERITOR CLEARANCE SENSING AUTOMATIC SLACK ADJUSTERS

HARDWARE

	EUCLID PART NO.	DESCRIPTION	REPLACES	NOTES
	R810317	Anchor Screw	443-10188	Length 1-1/4", 7/16"-14 thread. Use with R810324 slide nut.
	R810321	Anchor Screw	443-10096	Length 1", 7/16"-14 thread.
	R810319	Bracket		
	R810322	Bushing	452-10058	1/2" I.D. x 5/8" O.D.
	R810323	Bushing	452-10128	Serrated. 5/8" I.D. x 13/16" O.D.
	R810325	Double Flat Stud	443-10299	3" length.
	R810326	Double Flat Stud	443-10290	2-3/4" length.

MERITOR CLEARANCE SENSING AUTOMATIC SLACK ADJUSTERS

HARDWARE







	EUCLID PART NO.	DESCRIPTION	REPLACES	NOTES
	R810316	Fitting Kit		
	R810320	Flange Nut	443-10204	7/16"-14 thread.
	R810318	Grommet	452-10125	1-9/32" length x 11/16" width.
	R810327	Service Kit	427-10558	Includes 4 cap nuts, 4 anchor pins, 4 bushings. Services 4 ASA's.
	R810324	Slide Nut	443-10101	7/16"-14 thread.

SERVICE BRACKET KITS

	EUCLID PART NO.	APPLICATION	BRACKET STYLE	REPLACES	NOTES
	R810302	Drive and Steer Axle	Clamp	427-10566K	2-1/4" clamp. For use with Mack 16,000 lb.+ brakes.

MERITOR CLEARANCE SENSING AUTOMATIC SLACK ADJUSTERS

SERVICE BRACKET KITS

	EUCLID PART NO.	APPLICATION	BRACKET STYLE	REPLACES	NOTES
	R810311	Drive Axle	Clamp	427-10421	2-1/4" - 2-1/2" tube clamp.
	R810314	Drive Axle	Clamp	427-10420	2-1/4" - 2-1/2" tube clamp.
	R810303	Steer Axle	Clamp	427-10567K	2" u-bolt clamp.
	R810310	Steer Axle	Clamp	427-10497	2-1/4" clamp. For use with 5/8" offset asa's.
	R810301	Trailer Axle	Plate and Stud	427-10563	Cam support bracket
	R810307	Trailer Axle	Plate and Stud		Cam support bracket

MERITOR CLEARANCE SENSING AUTOMATIC SLACK ADJUSTERS

SERVICE BRACKET KITS

	EUCLID PART NO.	APPLICATION	BRACKET STYLE	REPLACES	NOTES
	R810308	Trailer Axle	Plate and Stud	427-10565	Cam support bracket with control arm bushing.
	R810304	Steer Axle, Transit	Spider	427-10548	3-3/4" bracket. For use with Mack 16,000 lb.+ steer axle brakes with 1-1/2" offset. Also used on Transit applications.
	R810313		Strap	427-10582	
	R810305	Drive and Steer Axle, Transit	Strap	427-10543	1-1/4" x 6-1/2" strap. For use with Meritor air disc brakes.
	R810306	Drive Axle	Strap	427-10554	1-1/4" x 4-3/4" strap. For use with Kenworth 8 air bag drive axle brakes.

MERITOR CLEARANCE SENSING AUTOMATIC SLACK ADJUSTERS

SERVICE BRACKET KITS



EUCLID PART NO.	APPLICATION	BRACKET STYLE	REPLACES	NOTES
R810300	Drive Axle, Transit	Strap	427-10553K	Angled 1-1/4" x 7" strap
R810309	Transit	Strap	427-10579	1-3/4" x 4-1/2" strap
R810315	Transit	Strap	427-10517	1-1/4" x 5-1/2" strap.
R810312	Transit	Stud	427-10517	

GUNITE AUTOMATIC SLACK ADJUSTERS

Features and Benefits

- 5", 5-1/2", 6", 6-1/2" arm lengths
- Straight or offset clevis with 1/2" or 5/8" threads
- Unhanded design
- Unique clearance sensing design and exclusive two-way adjustment
- Compact housing for easy installation
- Double sealed actuator arm
- Drilled worm gear
- Factory lubricated and sealed to protect against dirt, water, salt and other corrosive elements
- Extended life clevis pin bushing
- O-ring on spline gear
- Available in 10, 24, 28, or 37 spline configurations

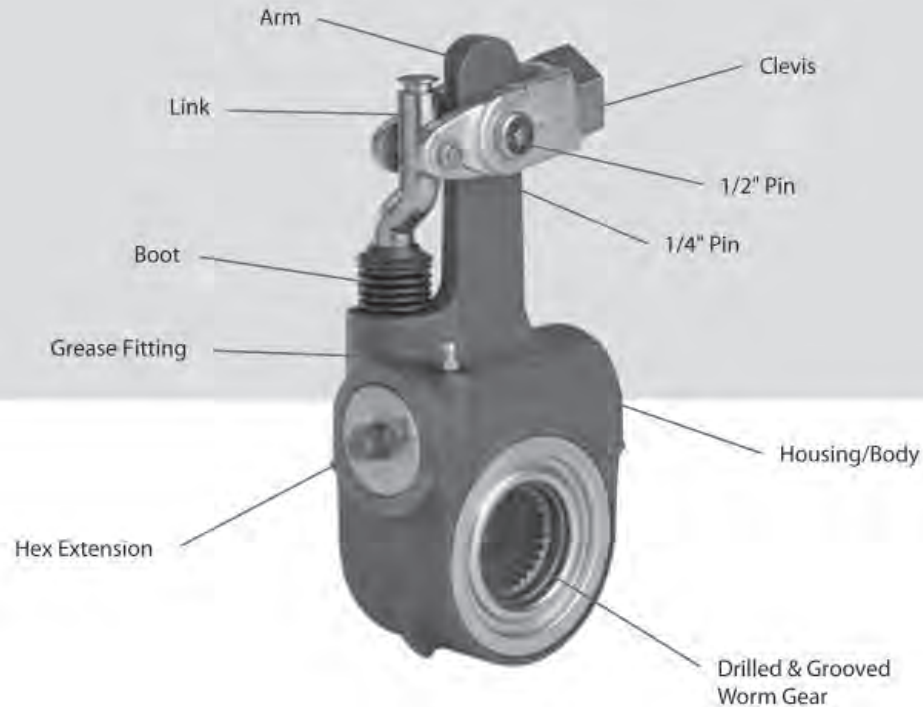

GUNITE AUTOMATIC SLACK ADJUSTERS

FRONT STEER AXLE APPLICATIONS

Euclid Part Number	Clevis Kit Number	Spline Size	Arm Length	Comments
E-15004	n/a	1-1/4"-10	5"	Replaces AS1035
E-15019	E-15072	1-1/4"-10	5"	Replaces AS1135
E-15005	n/a	1-1/4"-10	5-1/2"	Replaces AS1036
E-15020	E-15072	1-1/4"-10	5-1/2"	Replaces AS1136
E-15036 ¹	E-15063	1-1/4"-10	5-1/2"	Replaces AS1152
E-15037 ²	E-15064	1-1/4"-10	5-1/2"	Replaces AS1153
E-15053	n/a	1-1/4"-10	5-1/2"	Replaces AS1170
E-15006	n/a	1-1/4"-24	5"	Replaces AS1037
E-15021	E-15072	1-1/4"-24	5"	Replaces AS1137
E-15007	n/a	1-1/4"-24	5-1/2"	Replaces AS1038
E-15022	E-15072	1-1/4"-24	5-1/2"	Replaces AS1138
E-15038 ¹	E-15063	1-1/4"-24	5-1/2"	Replaces AS1154
E-15039 ²	E-15064	1-1/4"-24	5-1/2"	Replaces AS1155
E-15054	n/a	1-1/4"-24	5-1/2"	Replaces AS1171
E-15001	n/a	1-1/2"-10	5-1/2"	Replaces AS1032
E-15016	E-15072	1-1/2"-10	5-1/2"	Replaces AS1132
E-15051	n/a	1-1/2"-10	5-1/2"	Replaces AS1168
E-15009	n/a	1-1/2"-28	5-1/2"	Replaces AS1040
E-15024	E-15072	1-1/2"-28	5-1/2"	Replaces AS1140
E-15055	n/a	1-1/2"-28	5-1/2"	Replaces AS1172

¹ .625" offset, 1/2" - 20 thread Clevis.

² .625" offset, 5/8" - 18 thread Clevis.

GUNITE AUTOMATIC SLACK ADJUSTERS

REAR DRIVE AXLE APPLICATIONS

Euclid Part Number	Clevis Kit Number	Spline Size	Arm Length	Comments
E-15000	n/a	1-1/2"-10	5"	Replaces AS1031
E-15015	E-15069	1-1/2"-10	5"	Replaces AS1131
E-15001	n/a	1-1/2"-10	5-1/2"	Replaces AS1032
E-15016	E-15072	1-1/2"-10	5-1/2"	Replaces AS1132
E-15040 ²	E-15064	1-1/2"-10	5-1/2"	Replaces AS1156
E-15051	n/a	1-1/2"-10	5-1/2"	Replaces AS1168
E-15002	n/a	1-1/2"-10	6"	Replaces AS1033
E-15017	E-15069	1-1/2"-10	6"	Replaces AS1133
E-15052	n/a	1-1/2"-10	6"	Replaces AS1169
E-15060	---	1-1/2"-10	6"	Replaces AS1179
E-15003	n/a	1-1/2"-10	6-1/2"	Replaces AS1034
E-15018	E-15069	1-1/2"-10	6-1/2"	Replaces AS1134
E-15057	n/a	1-1/2"-10	6-1/2"	Replaces AS1174
E-15008	n/a	1-1/2"-28	5"	Replaces AS1039
E-15023	E-15069	1-1/2"-28	5"	Replaces AS1139
E-15009	n/a	1-1/2"-28	5-1/2"	Replaces AS1040
E-15024	E-15072	1-1/2"-28	5-1/2"	Replaces AS1140
E-15041 ²	E-15064	1-1/2"-28	5-1/2"	Replaces AS1157
E-15055	n/a	1-1/2"-28	5-1/2"	Replaces AS1172
E-15010	n/a	1-1/2"-28	6"	Replaces AS1041
E-15025	E-15069	1-1/2"-28	6"	Replaces AS1141
E-15056	n/a	1-1/2"-28	6"	Replaces AS1173
E-15059	---	1-1/2"-28	6"	Replaces AS1176
E-15011	n/a	1-1/2"-28	6-1/2"	Replaces AS1042
E-15026	E-15069	1-1/2"-28	6-1/2"	Replaces AS1142
E-15058	n/a	1-1/2"-28	6-1/2"	Replaces AS1175

2. .625" offset, 5/8" - 18 thread Clevis.

GUNITE AUTOMATIC SLACK ADJUSTERS

TRAILER AXLE APPLICATIONS

Euclid Part Number	Clevis Kit Number	Spline Size	Arm Length	Comments
E-15030	E-15071	1-1/2"-10	5-1/2"	Replaces AS1146
E-15045 ³	E-15073	1-1/2"-10	5-1/2"	Replaces AS1162
E-15051	n/a	1-1/2"-10	5-1/2"	Replaces AS1168
E-15031	E-15071	1-1/2"-10	6"	Replaces AS1147
E-15046 ³	E-15073	1-1/2"-10	6"	Replaces AS1163
E-15052	n/a	1-1/2"-10	6"	Replaces AS1169
E-15060	AS3024	1-1/2"-10	6"	Replaces AS1179
E-15032	E-15071	1-1/2"-10	6-1/2"	Replaces AS1148
E-15047 ³	E-15073	1-1/2"-10	6-1/2"	Replaces AS1164
E-15057	n/a	1-1/2"-10	6-1/2"	Replaces AS1174
E-15033	E-15071	1-1/2"-28	5-1/2"	Replaces AS1149
E-15048 ³	E-15073	1-1/2"-28	5-1/2"	Replaces AS1165
E-15055	n/a	1-1/2"-28	5-1/2"	Replaces AS1172
E-15034	E-15071	1-1/2"-28	6"	Replaces AS1150
E-15049 ³	E-15073	1-1/2"-28	6"	Replaces AS1166
E-15056	n/a	1-1/2"-28	6"	Replaces AS1173
E-15059	AS3023	1-1/2"-28	6"	Replaces AS1176
E-15035	E-15071	1-1/2"-28	6-1/2"	Replaces AS1151
E-15050 ³	E-15073	1-1/2"-28	6-1/2"	Replaces AS1167
E-15058	n/a	1-1/2"-28	6-1/2"	Replaces AS1175
E-15012	n/a	1-5/8"-37	5-1/2"	Replaces AS1043
E-15027	E-15071	1-5/8"-37	5-1/2"	Replaces AS1143
E-15042 ³	E-15073	1-5/8"-37	5-1/2"	Replaces AS1159
E-15013	n/a	1-5/8"-37	6"	Replaces AS1044
E-15028	E-15071	1-5/8"-37	6"	Replaces AS1144
E-15043 ³	E-15073	1-5/8"-37	6"	Replaces AS1160
E-15014	n/a	1-5/8"-37	6-1/2"	Replaces AS1045
E-15029	E-15071	1-5/8"-37	6-1/2"	Replaces AS1145
E-15044 ³	E-15073	1-5/8"-37	6-1/2"	Replaces AS1161

³ Extended length collar lock Clevis with stainless steel pins.

GUNITE AUTOMATIC SLACK ADJUSTERS

HARDWARE

Euclid Part No.	Clevis Type	Style	Push Rod Thread	Comments	Application Information
E-15061	Threaded	Straight	5/8"-18	Replaces AS3000	
E-15062	Threaded	Straight	1/2"-20	Replaces AS3001	
E-15063	Threaded	5/8" Offset	1/2"-20	Replaces AS3002	
E-15064	Threaded	5/8" Offset	5/8"-18	Replaces AS3003	
E-15065 ⁴	Threaded	Straight	5/8"-18	Replaces AS3011	For application with 5/8" Clevis Pins
E-15066 ⁴	Threaded	Straight	1/2"-20	Replaces AS3012	For application with 5/8" Clevis Pins
E-15067	Extended Threaded	Straight	5/8"-18	Replaces AS3013	
E-15068	Extended Threaded	Straight	5/8"-18	Replaces AS3015	Furnished with Stainless Steel Clevis Pins
E-15069	Collar Lock	Straight	5/8"-18	Replaces AS3016	
E-15070	Collar Lock	Straight	1/2"-20	Replaces AS3017	
E-15071	Extended Collar Lock	Straight	5/8"-18	Replaces AS3018	
E-15072	Collar Lock	Straight	1/2"-20 & 5/8"-18	Replaces AS3019	Furnished with (1) 1/2" and (1) 5/8" Collar Nuts
E-15073	Extended Collar Lock	Straight	5/8"-18	Replaces AS3021	With Stainless Steel Clevis Pins

Above referenced Automatic Slack Adjuster Kits are furnished with a Clevis that has a 1" pin center distance. When installing or replacing a Gunite Automatic Slack Adjuster, it is recommended that a new clevis assembly be installed in accordance with the Gunite Automatic Slack Adjuster Service Manual.

Euclid Part No.	Description	Contents	Comments	Notes
E-15074	Link Boot & Arm Bushing Kit	(1) Link Boot, (1) 1/2" Steel Arm Bushing	Replaces AS4001	Serves older 4 bellows design mfg to 01/01/2005
E-15075	Clevis Pin Kit	(6) 1/2" Clevis Pins, (6) 1/4" Clevis Pins, (12) Cotter Pins	Replaces AS4004	
E-15076 ⁴	Arm Bushing Kit	(24) 5/8" Steel Arm Bushings	Replaces AS4005	For appl with 5/8" Clevis Pins
E-15077 ⁴	Clevis Pin Kit	(6) 5/8" Clevis Pins, (6) 1/4" Clevis Pins, (12) Cotter Pins	Replaces AS4006	For appl with 5/8" Clevis Pins
E-15078 ⁴	Link Boot & Arm Bushing Kit	(1) Link Boot, (1) 5/8" Steel Arm Bushing	Replaces AS4007	For appl with 5/8" Clevis Pins
E-15079	Installation Gauge	OEM Installation Guide	Replaces AS4008	
E-15080	Stainless Steel Clevis Pin Kit	(6) 1/2" Clevis Pins, (6) 1/4" Clevis Pins, (12) Cotter Pins	Replaces AS4012	Stainless Steel Components
E-15081	Collar Lock Nuts	(4) 1-1/4" Locking Nuts, (4) 5/8"-18 Collar Nuts	Replaces AS4013	
E-15082	Collar Lock Nuts	(4) 1-1/4" Locking Nuts, (4) 1/2"-20 Collar Nuts	Replaces AS4014	
E-15083	Arm Bushing Kit	(24) 1/2" Steel Arm Bushings	Replaces AS4015	

(4) For older applications requiring 5/6" diameter clevis pins

CREWSON INDUSTRIES AUTOMATIC SLACK ADJUSTER KITS

FEATURES

- Clearance AND Load Sensing
- Link Rod Actuation
- Adjusts on Return Stroke
- Easy Manual Adjustment
- Extra Grease Sealing
- Fewer Part Numbers for Full Coverage:
 - Less Confusion
 - Reduced Inventory
- "User-Friendly" Installation Guide
 - Included in Each Kit
- Corrosion Resistant "E" Coating

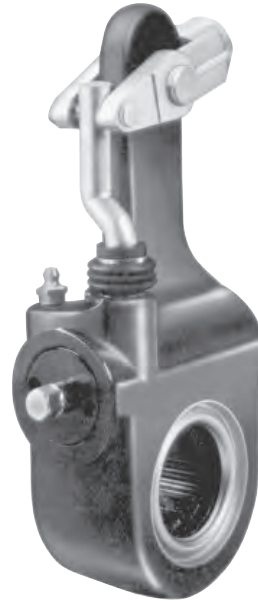

Installation Guide

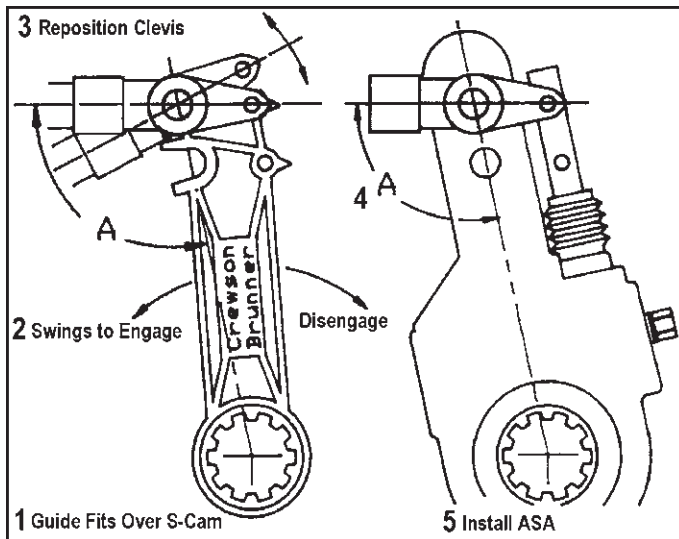

Procedure

1. Guide fits on the S-Cam before Automatic Slack Adjuster is installed.
2. Installation guide easily swings to engage clevis pin.
3. Reposition clevis until holes line up with guide.
4. Guide indicates exact set up angle "A".
5. Automatic Slack Adjuster is now installed without excessive manual adjustment that wears adjuster components.

CREWSON AUTOMATIC SLACK ADJUSTER KITS

15" STEERING AXLE APPLICATION



EUCLID KIT NO.	INCLUDES CLEVIS	SPLINE SIZE	ARM LENGTH	APPLICATION & GENERAL INFORMATION
E-6988A	5/8"-18 Offset 5/8"	1-1/4"-10	5-1/2"	For Meritor "T" Series & Eaton Single Anchor Brakes.
E-6987A	5/8"-18 Straight			
E-6990A	5/8"-18 Offset 5/8"	1-1/4"-24	5-1/2"	For Meritor "Q" and "T" Series Brakes.
E-6989A	5/8"-18 Straight			

16-1/2" DRIVE AND TRAILER AXLE APPLICATION



EUCLID KIT NO.	INCLUDES CLEVIS	SPLINE SIZE	ARM LENGTH	APPLICATION & GENERAL INFORMATION
E-6991A	5/8"-18 Straight	1-1/2"-10	5" - 6"	For Bendix, Eaton, Fruehauf, Meritor and Spicer Brakes.
E-6992A	5/8"-18 Straight	1-1/2"-10	5-1/2" - 6-1/2"	
E-6993A	5/8"-18 Straight	1-1/2"-28	5" - 6"	For Eaton, Meritor and Spicer Brakes.
E-6994A	5/8"-18 Straight	1-1/2"-28	5-1/2" - 6-1/2"	
E-6995A	5/8"-18 Straight	1-5/8"-37	5" - 6"	For Fruehauf Brakes.
E-6996A	5/8"-18 Straight	1-5/8"-37	5-1/2" - 6-1/2"	

12-1/4" TRAILER AXLE APPLICATION



EUCLID KIT NO.	INCLUDES CLEVIS	SPLINE SIZE	ARM LENGTH	APPLICATION & GENERAL INFORMATION
E-10950A	5/8"-18 Straight	1-1/2"-10	5" - 6"	
E-10949A	5/8"-18 Straight	1-1/2"-28	5" - 6"	

CAUTION: DO NOT MIX AUTOMATIC SLACK ADJUSTER BRANDS ON THE SAME VEHICLE.

CREWSON AUTO-CHECK™ AUTOMATIC SLACK ADJUSTER KITS

EUCLID NO.	INCLUDES CLEVIS	SPLINE SIZE	ARM LENGTH	CHAMBER SIZE	CHAMBER STROKE	APPLICATION & GENERAL INFORMATION
E-11880	1/2"-20 Straight		5-1/2"	Type 16/20		For 15" Meritor and Eaton Steer Axle Applications
E-10784A		1-1/4"-10		Type 20/24	Standard	
E-11872	5/8"-18 Straight		6-1/2"	Type 30		For 16-1/2" Meritor, Eaton and Spicer Trailer Axle Applications.
E-11879	1/2"-20 Straight		5-1/2"	Type 16/20		For Meritor Q & T Series Brakes.
E-11877	5/8"-18 Straight	1-1/4"-24		Type 24	Standard	
E-10786A			5-1/2"		Long Stroke	For 16-1/2" Meritor and Eaton Drive Axle Applications.
E-10780A	5/8"-18 Straight	1-1/2"-10		Type 30	Standard	
E-10789A			6"		Long Stroke	For 16-1/2" Meritor, Eaton and Spicer Trailer Axle Applications.
E-10782A					Standard	
E-10785A			5-1/2"		Long Stroke	For 16-1/2" Meritor and Eaton Drive Axle Applications.
E-10779A					Standard	
E-10788A	5/8"-18 Straight	1-1/2"-28		Type 30	Long Stroke	For 16-1/2" Meritor, Eaton and Spicer Trailer Axle Applications.
E-10781A			6"		Standard	
E-11873			6-1/2"		Standard	
E-10787A			6"		Long Stroke	For 16-1/2" Fruehauf Trailer Axle Applications.
E-10783A	5/8"-18 Straight	1-5/8"-37		Type 30	Standard	
E-11875			6-1/2"		Standard	



CREWSON AUTOMATIC SLACK ADJUSTER CLEVIS KITS



EUCLID KIT NO.	FITS PUSH ROD THD.	STRAIGHT OR OFFSET	GENERAL INFORMATION
E-9135	5/8"-18	5/8" Offset	Clevis Kit contains: 1 1/2" Pin, 1 1/4" Pin, 1 Clevis, 2 Cotter Pins. Note: To be used with early design only. Pin C/L to C/L is 1-1/4". Color is Gold.
E-9132	1/2"-20	Straight	
E-9133	5/8"-18	Straight	
E-11884	1/2"-20	5/8" Offset	Clevis Kit contains: 1 1/2" Pin, 1 1/4" Pin, 1 Clevis, 2 Cotter Pins. Note: To be used with current design only. Pin C/L to C/L is 1-3/8". Color is Black.
E-11885	5/8"-18	5/8" Offset	
E-11883	1/2"-20	Straight	
E-11882	5/8"-18	Straight	
E-11881	1/2"-20	Straight Auto Check	
E-11890	5/8"-18	Straight Auto Check	

CAUTION: DO NOT MIX AUTOMATIC SLACK ADJUSTER BRANDS ON THE SAME VEHICLE.

SAFETY CHECK BRAKE GAUGES

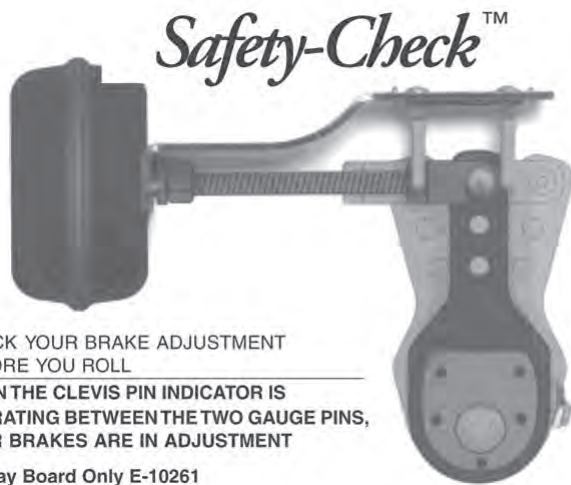

CHECK YOUR BRAKE ADJUSTMENT BEFORE YOU ROLL
 WHEN THE CLEVIS PIN INDICATOR IS OPERATING BETWEEN THE TWO GAUGE PINS, YOUR BRAKES ARE IN ADJUSTMENT
 Display Board Only E-10261

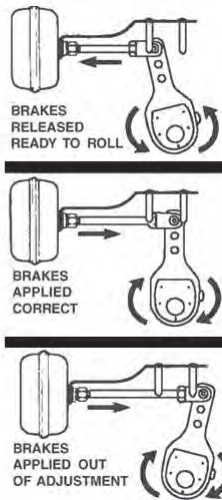

Drive Axle



Steer Axle

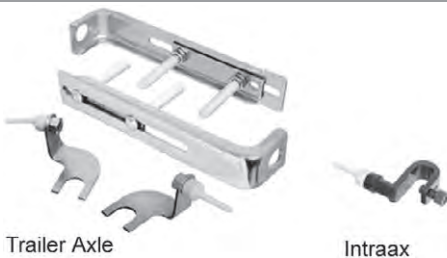

Trailer Axle

Intraax

EUCLID NO.	DESCRIPTION
E-10093A	1/2" Drive Axle Kit
E-10094A	5/8" Drive Axle Kit
E-10881-BK	LH 1/2 of Kit E-10093A
E-10882-BK	RH 1/2 of Kit E-10093A
E-10883-BK	LH 1/2 of Kit E-10994A
E-10884-BK	RH 1/2 of Kit E-10994A
E-10886	Drive Axle Kit for Mack Camel Back
E-10095A	1/2" Steer Axle Kit
E-10096A	5/8" Steer Axle Kit
E-10887-BK	LH 1/2 of Kit E-10095A
E-10888-BK	RH 1/2 of Kit E-10095A
E-10889-BK	LH 1/2 of Kit E-10096A
E-10890-BK	RH 1/2 of Kit E-10996A
E-10891	GMC Steer Axle Kit
E-10092A	Trailer Axle Kit
E-10879-BK	LH 1/2 of Kit E-10092A
E-10880-BK	RH 1/2 of Kit E-10092A
E-10885	Intraax® Trailer Axle Kit

SAFETY CHECK BRAKE GAUGES

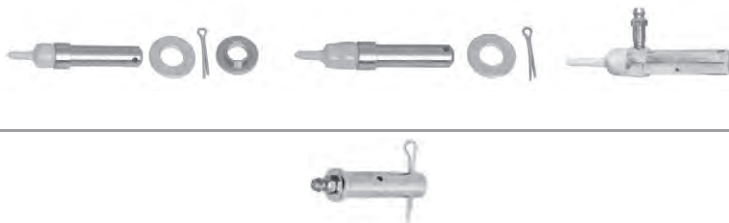

EUCLID NO.	DESCRIPTION
E-10097	1/2" Clevis Pin
E-10097G	1/2" Grease Type Clevis Pin
E-10098	5/8" Clevis Pin
E-10098G	5/8" Grease Type Clevis Pin
E-10952	Greasable Clevis Pin

PARTS FOR BENDIX WEDGE BRAKE



EUCLID NO.	REPLACES	SLOT WIDTH	APPLICATION AND GENERAL INFORMATION
E-2282	Dayton/Batco 07571	1/4"	Non-Servo. Adjusting Screw. Use with 15" x 3 and 3-1/2" shoes
	Dayton/Batco 08130600		
	Trailmobile 382282		
	Dana/Spicer 437037		
	Bendix 445342		
	Meritor KIT970		
	Leland L1301		
E-2281	Meritor R670022	5/16"	Twin Plex. Adjusting Screw. Use with 15" x 5, 6 and 7" shoes
	Dayton/Batco 07570		
	Bendix 318657		
	Bendix 445343		
	Leland L1300		
Meritor R670021			



EUCLID NO.	DESCRIPTION	REPLACES	O.D.	LENGTH	APPLICATION
E-1217	Adjusting Nut Cap	Dayton/Batco 07586			
		Bendix 316355			
		Haldex 65401			
		Leland L972			
		Meritor R670004			
		Meritor R670029			



E-1486	Pin	Dayton/Batco 07605	2-1/2"	Available only in Brake Kits E-2157, E-2159 and E-2746
		Bendix 316331		
		Haldex 66680		
		Leland L1066		
		Meritor R670027		



E-1894 ¹	Universal Anchor Piston	Dayton/Batco 07-593		2 piece (formerly 1 piece). Available only in Brake Kit E-2157
		Bendix 316386		
		Bendix 316387		
		Bendix 325007		
		Haldex 65402		
		Leland L973		
Meritor R670028				



E-2161	Adjusting Lever	Dayton/Batco 07600		
		Bendix 249940		
		Leland L1013		
		Meritor R670018		



E-2162	Adjusting Spring	Dayton/Batco 07601	3/4"	1-1/2"
		Bendix 249941		
		Bendix 316370		
		Leland L1012		
		Meritor R670019		



E-2164	Spring Damper	Dayton/Batco 07534	29/32"	2"	Use with E-2163 Spring. Available only in Brake Kits E-2157 and E-2158.
		Bendix 249943			
		Leland L1015			
		Leland L1764			



EUCLID NO.	DESCRIPTION	REPLACES
E-1216	Adjusting Nut	Dayton/Batco 07585
		Bendix 316354
		Haldex 65400
		Leland L971
		Meritor R670003

¹ Not Sold Separately

PARTS FOR BENDIX WEDGE BRAKE



EUCLID NO.	DESCRIPTION	REPLACES
E-1493	Pin	Bendix 049624
		Dayton/Batco 07523

- Trailmobile 381493
- Bendix H1110
- Bendix H1110DP
- Leland K30
- Meritor R401493
- Meritor R4049624
- Meritor R670007
- Bendix 023969
- Dayton/Batco 07523
- Wagner F23880
- Bendix H1132
- Leland K30
- Meritor R401495
- Meritor R4023969
- Meritor R670008
- Dayton/Batco 07590
- Bendix 316349
- Bendix 324756
- Leland L970
- Meritor R670005



E-1495	Cap
---------------	-----



E-1218	Adjusting Piston
---------------	------------------



BLACK

EUCLID NO.	REPLACES	COIL O.D.	LENGTH
E-1496	Dayton/Batco 07523	3/4"	1-1/2"
	Bendix 316368		
	Leland K30		
	Meritor R670009		



GREEN

EUCLID NO.	REPLACES	O.D.	LENGTH	APPLICATION
E-1497	Dayton/Batco 07536	5/8"	6-9/16"	For Bendix "Non-Servo" Front Brakes
	Bendix 316367			
	Bendix 316392			
	Haldex 65414			
	Haldex 66679			
	Haldex C66753			
	Haldex CS66679			
	Leland L1065			
	Meritor R670010			



BLACK

E-2163	Dayton/Batco 07535	15/16"	7-1/2"	For "Twin-plex" Drive and Trailer Wedge Brakes. Use with E-2164 Damper.
	Bendix 249942			
	Haldex C65414			
	Leland L1765			
	Meritor R670020			



E-2552	Dayton/Batco 07524	1/8"	7-1/2"	Shoe Stabilizer Guide used on Late Model spider with wide shoe guide.
	Bendix 445280			
	Leland L1706			
	Meritor R670023			



RED

E-2745	Dayton/Batco 07537	15/16"	8-3/8"	For Bendix "Non-Servo" Front Brake
	Bendix 324095			
	Bendix 324095N			
	Haldex C63042			
	Leland L1769			
Meritor R670024				

PARTS FOR BENDIX WEDGE BRAKE



EUCLID NO.	DESCRIPTION	REPLACES
E-1214	Adjusting Piston Boot	Dayton/Batco 07574
		Bendix 317071
		Bendix 318658
		Bendix 324330
		Trailmobile 381214
		Haldex 65323
E-1230	Anchor Piston Boot	Leland L1010
		Meritor R670001
		Dayton/Batco 07595
		Bendix 318564
		Haldex 65412
		Leland L1014
Meritor R670006		

WEDGE ASSEMBLIES



EUCLID NO.	REPLACES	WEDGE ANGLE	AXLE APPLICATION
E-2153	Dayton/Batco 07554	10°	Trailer
	Bendix 285783		
	Bendix 3200070		
	Trailmobile 382153		
	Haldex 65404		
	Leland L975		
E-2154	Meritor R670011	12°	Drive and Trailer
	Dayton/Batco 07551		
	Bendix 285784		
	Bendix 318598		
	Bendix 3200709		
	Leland L1708		
E-2155	Meritor R670012	14°	Drive
	Dayton/Batco 07552		
	Bendix 285785		
	Bendix 318599		
	Bendix 3200710		
	Trailmobile 382155		
E-2156	Leland L1709	18°	Steering
	Meritor R670013		
	Dayton/Batco 07553		
	Bendix 285786		
	Bendix 318601		
	Bendix 3200449		
Leland L1710			
Meritor R670014			

KITS FOR BENDIX WEDGE BRAKES

E-2157 MAJOR OVERHAUL KIT FOR BENDIX "TWINPLEX" WEDGE BRAKE



ITEM	QTY.	EUCLID NO.	DESCRIPTION	APPLICATION & GENERAL INFORMATION
1	2	E-2281	Adjusting Screw	Universal for both left and right.
2	2	E-1214	Adjusting Piston Boot	Services one Brake Assembly.
3	2	E-1215	Adjusting Overload Spring	REPLACES: Dayton/Batco 081932
4	2	E-1216	Adjusting Nut	Dayton/Batco 08193200
5	2	E-1217	Adjusting Nut Cap	Bendix 100140
6	2	E-1218	Adjusting Piston	Dana/Spicer 110A
7	2	E-2162	Adjusting Lever Spring	Trailmobile 382157
8	2	E-2161	Adjusting Lever	Haldex CQ66742
9	2	E-1486	Adjusting Lever Pin	Leland K235
10	2	NSS	Piston Assembly	Leland K31
11	2	E-1230	Anchor Piston Boot	Leland K31Z
12	2	E-2163	Return Spring	Meritor R670015
13	2	E-2164	Spring Damper	
14	1	NSS	Lubricant (not shown)	

E-2158 MINOR OVERHAUL KIT FOR BENDIX "TWINPLEX" WEDGE BRAKE

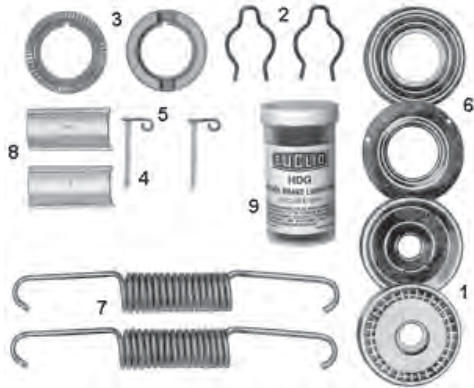

ITEM	QTY.	EUCLID NO.	DESCRIPTION	APPLICATION & GENERAL INFORMATION
1	2	E-1214	Adjusting Piston Boot	Services one Brake Assembly.
2	2	E-1215	Adjusting Nut Spring	REPLACES: Dayton/Batco 081930
3	2	E-1217	Adjusting Nut Cap	Dayton/Batco 08193303
4	2	E-2162	Adjusting Lever Spring	Dana/Spicer 111A
5	2	E-2161	Adjusting Lever	Bendix 319114
6	2	E-1230	Piston Boot	Haldex CQ669130
7	2	E-2163	Return Spring	Leland K64
8	2	E-2164	Spring Damper	Meritor R670016
9	1	E-2015	Wedge Brake Lubricant	

E-2159 MAJOR OVERHAUL KIT FOR BENDIX "NON-SERVO" WEDGE BRAKE

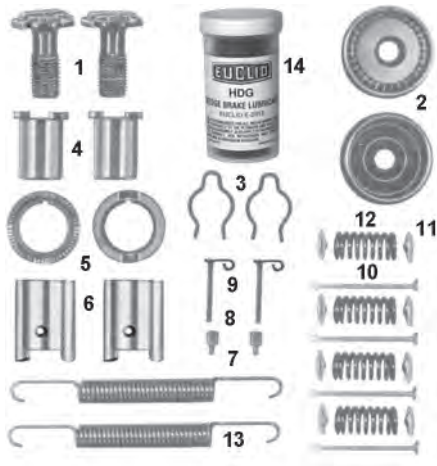

ITEM	QTY.	EUCLID NO.	DESCRIPTION	APPLICATION & GENERAL INFORMATION
1	2	E-2282	Adjusting Screw	Use with Brake Shoe E-1512 (3").
2	2	E-1214	Adjusting Piston Boot	Services one Brake Assembly.
3	2	E-1215	Adjusting Nut Spring	REPLACES: Dayton/Batco 081937
4	2	E-1216	Adjusting Nut	Bendix 100144
5	2	E-1217	Adjusting Nut Cap	Dana/Spicer 114A
6	2	E-1218	Adjusting Piston	Haldex CQ66743
7	2	E-1486	Adjusting Lever Pin	Haldex CQ669140
8	2	E-2162	Adjusting Lever Spring	Leland K236
9	2	E-2161	Adjusting Lever	Leland K32
10	4	E-1493	Hold Down Shoe Pin	Meritor R670017
11	8	E-1495	Hold Down Shoe cup	
12	4	E-1496	Hold Down Shoe Spring	
13	2	E-1497	Return Spring	
14	1	E-2015	Wedge Brake Lubricant	

KITS FOR BENDIX WEDGE BRAKES

E-2746

OVERHAUL KIT FOR BENDIX "NON-SERVO" FRONT AXLE WEDGE BRAKE

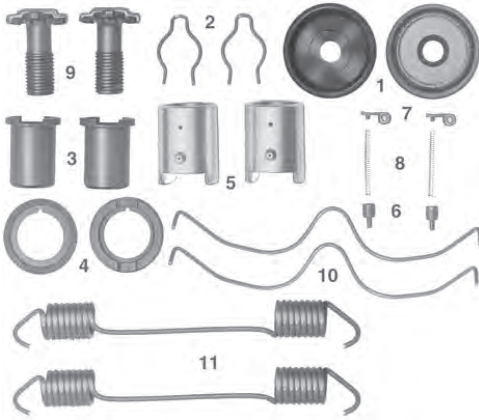

ITEM	QTY.	EUCLID NO.	DESCRIPTION	APPLICATION & GENERAL INFORMATION
1	2	E-1214	Adjusting Piston Boot	Kit does not include E-2744 insert which is not replaced in new brakes. Includes Wedge Brake Lubricant (not shown; not sold separately). Services one Brake Assembly. REPLACES: Dayton/Batco 08-1934 Dayton/Batco 08193204 Bendix 100150 Bendix 100151 Trailmobile 382746 Dayton/Batco 81934 Leland K308 Leland K311 Meritor R670025
2	2	E-1215	Adjusting Nut Spring	
3	2	E-1216	Adjusting Nut	
4	2	E-1217	Adjusting Nut Cap	
5	2	E-1218	Adjusting Piston	
6	2	E-1486	Adjusting Lever Pin	
7	2	E-2161	Adjusting Lever	
8	2	E-2162	Adjusting Lever Spring	
9	2	E-2281	Adjusting Screw	
10	2	E-2552	Shoe Stabilizer Spring	
11	2	E-2745	Return Spring	
12	1	NSS*	Lubricant (not shown)	



EUCLID NO.	DESCRIPTION	REPLACES
E-1215	Adjusting Nut Spring	Dayton/Batco 07587 Bendix 316356 Haldex 65409 Leland L1011 Meritor R670002

E-2015



EUCLID "HDG" WEDGE BRAKE LUBRICANT

APPLICATION

HDG is recommended for all Wedge Brakes. Apply HDG generously to the Plungers and Rollers of the Wedge Assembly and to the inside of the Seal Assembly also. Each can is 6-1/2 oz.

- HDG is formulated to:
- * Withstand High Temperatures
 - * Be Waterproof
 - * Be Corrosion Resistant
 - * Provide Long Life
 - * Resist Extreme Pressure
 - * Be Smooth In Texture
 - * Have A Thin Film Capacity

*Not Sold Separately

MERITOR "STOPMASTER" WEDGE BRAKE PARTS

ADJUSTING BOLTS



EUCLID NO.	REPLACES	APPLICATION AND GENERAL INFORMATION
E-2484	Dayton/Batco 07163	For 12-1/4" RD Brakes and 15" Rear RD Brakes.
	Dayton/Batco 07169	
	Meritor 2297D2370	
	Meritor A2297L3158	
	Leland L1188	
Leland L1317		



E-3492	Dayton/Batco 07168	For 15" Front RS and RD Brakes, Backing Plate Mounted.
	Navistar 487480C91	
	Meritor A2297V2882	
	Leland L1046	

ADJUSTING SLEEVES



EUCLID NO.	REPLACES	APPLICATION AND GENERAL INFORMATION
E-3499	Dayton/Batco 07187	For 15" Front RS and RD Brakes, Backing Plate Mounted. Use with E-3492 Adjusting Bolt. Use with E-5540 Pawl Assembly.
	Meritor 2297N2874	
	Navistar 487479C1	



E-5531	Meritor 3280Y8189	Blue Plated. For 12-1/4" RD Brakes and 15" Rear RD Brakes. Use with E-2484 or E-2485 Adjusting Bolts. Use with E-5539 Pawl Assembly. Replaces E-2486.
	Leland L3053	

ADJUSTING PLUNGER ASSEMBLIES TO CONVERT OLDER "STOPMASTER" MODELS TO CURRENT STYLE



EUCLID NO.	REPLACES	WEDGE DEGREE	INCLUDES
E-3996	Dayton/Batco 07230	10°	1 E-5533 Adjusting Plunger 1 E-5531 Adjusting Sleeve 1 E-5539 Pawl Assembly
	Meritor A3280U8185		
E-3997	Dayton/Batco 07231	12°	1 E-5534 Adjusting Plunger 1 E-5531 Adjusting Sleeve 1 E-5539 Pawl Assembly
	Dayton/Batco 7191		
	Meritor A3280V8186		
	Leland L3055		
	Leland L762		
E-3998	Dayton/Batco 07232	14°	1 E-5535 Adjusting Plunger 1 E-5531 Adjusting Sleeve 1 E-5539 Pawl Assembly
	Dayton/Batco 7192		
	Meritor A3280W8187		
E-3999	Dayton/Batco 07233	16°	1 E-5536 Adjusting Plunger 1 E-5531 Adjusting Sleeve 1 E-5539 Pawl Assembly
	Dayton/Batco 7193		
	Meritor A3280X8188		

MERITOR "STOPMASTER" WEDGE BRAKE PARTS

ADJUSTING PLUNGERS



EUCLID NO.	REPLACES	WEDGE DEGREE	APPLICATION AND GENERAL INFORMATION
E-5538	Dayton/Batco 07195 Dayton/Batco 07201 Meritor 2297D2864 Meritor 2797D134 Navistar 303845C1	14°	Replaces E-2736



ANCHOR PLUNGERS





EUCLID NO.	LH/RH	REPLACES	WEDGE DEGREE	APPLICATION AND GENERAL INFORMATION
E-2135	LH	Dayton/Batco 07210 Meritor 2297A5123 Meritor 2297W5327 Meritor 2797Y415 Navistar 330856C1	10°	
E-2134	RH	Dayton/Batco 07211 Meritor 2297X5328 Meritor 2797X414 Navistar 330855C1		
E-1137	LH	Dayton/Batco 07212 Trailmobile 17274 Trailmobile 17374 Meritor 2297C419 Meritor 2297Y5329 Navistar 239664C1 Meritor 2797C419 Trailmobile 381137 Haldex 65398 Haldex 66439 Leland L782	12°	
E-1136	RH	Dayton/Batco 07213 Trailmobile 17275 Trailmobile 17375 Meritor 2297B418 Meritor 2297Z5330 Meritor 2797B418 Navistar 329665C1 Trailmobile 381136 Haldex 65397 Haldex 66440 Leland L781		For Drive and Trailer Brakes.
E-2137	LH	Dayton/Batco 07214 Meritor 2297A5331 Meritor 2797G423 Navistar 327187C1	14°	
E-2136	RH	Dayton/Batco 07215 Meritor 2297B5332 Meritor 2797F422 Navistar 327188C1		
E-2139	LH	Dayton/Batco 07216 Meritor 2297C5333 Meritor 2797J426	16°	
E-2138	RH	Dayton/Batco 07-217 Meritor 2297T5350 Meritor 2797H424 Dayton/Batco 7217		

MERITOR "STOPMASTER" WEDGE BRAKE PARTS

SEALS

	EUCLID NO.	REPLACES	COLOR	APPLICATION AND GENERAL INFORMATION
	E-3994	Dayton/Batco 07173 Meritor 1205C2005 Trailmobile 383994 Haldex 66681 Meritor A11705K219 Leland L1178	Blue	Adjusting Bolt Seal. For 12-1/4" RD Brakes and 15" Rear RD Brakes.
	E-3995	Dayton/Batco 07174 Meritor 1205B2004 Trailmobile 15333 Navistar 327185C91 Trailmobile 383995 Meritor A1705K219 Leland L760	Blue	Anchor Seal. For 12-1/4" RD Brakes and 15" Rear RD Brakes.
	E-5532	Dayton/Batco 07177 Dayton/Batco 07178 Dayton/Batco 07179 Navistar 264630C91 Meritor A1705M221 Meritor A1705W127 Meritor A21705M221 Meritor A31705M221 Leland L1047 Leland L1499	Green	Adjusting Bolt and Anchor Seal for 15" Front Brakes. Replaces E-1447, E-1518

ADJUSTING PAWL ASSEMBLIES

	EUCLID NO.	REPLACES	INCLUDES	APPLICATION AND GENERAL INFORMATION
	E-5539	Meritor A2-2297-U-4597 Leland L3054	1 Adjuster Pawl 1 Pawl Spring Cap 1 Pawl Spring 1 Seal	For Drive and Trailer Brakes 1986 - Up. Use With E-5531 Adjusting Sleeve.
	E-5540	Dayton/Batco 07256 Dayton/Batco 07270 Dayton/Batco 07272 Meritor A2297B5670 Leland L1183 Leland L1184	1 Adjuster Pawl, 1 Pawl Spring Cap, 1 Pawl Spring	For Front Brakes Use With E-3499 Adjusting Sleeve. Also for Pre-1986 Drive and Trailer Brakes. Replaces: E-2190, E-2191, E-2192

ANCHOR PLUNGER GUIDE AND SEAL ASSEMBLY

	EUCLID NO.	REPLACES	INCLUDES	APPLICATION AND GENERAL INFORMATION
	E-5541	Dayton/Batco 07246 Trailmobile 19060 Navistar 258024C1 Trailmobile 385541 Haldex 65387 Meritor A1779M195 Leland L755	1 Anchor Plunger Guide 1 Seal	For All Dual-Actuated Brakes. Replaces: E-1118, E-1117

MERITOR "STOPMASTER" WEDGE BRAKE PARTS

WEDGE ASSEMBLIES (WEDGE DEGREE STAMPED ON END OF WEDGE STEM)



EUCLID NO.	REPLACES	WEDGE DEGREE	APPLICATION INFORMATION
E-2140	Dayton/Batco 07150 Navistar 358224C91 Meritor A2247C1017 Meritor A2747G111	10°	
E-1261	Dayton/Batco 07151 Trailmobile 17345 Navistar 340210C91 Trailmobile 381261 Meritor A2247D1018 Meritor A2747H112 Leland L773 Leland L985	12°	
E-2141	Dayton/Batco 07152 Navistar 361716C91 Meritor A2247E1019 Meritor A2747J114	14°	
E-2142	Dayton/Batco 07153 Meritor A2247F1020 Meritor A2747K115	16°	

WEDGE BRAKE SHOES - RS AND RD



EUCLID NO.	REPLACES	SIZE	FMSI NO.	RIVET NO.
E-1457	Dayton/Batco 07103 Dana/Spicer 21938 Meritor A3722E681 Leland L1039	15" x 3-1/2"	4562A	8-7
E-2689	Dayton/Batco 07105 Dana/Spicer 21935 Dana/Spicer 4615RW Meritor A3722T358 Leland L1292	15" x 5"	4615	10-9
E-1139	Dayton/Batco 07107 Dana/Spicer 21933 Trailmobile 40727 Dana/Spicer 4602RW Dana/Spicer 4602S Haldex 65454 Trailmobile 7-3-11 Meritor A3222S2021 Meritor A3722V360 Leland L787	15" x 7"	4602	10-9





WEDGE BRAKE SHOE - RS WITH ANCHOR PIN



EUCLID NO.	REPLACES	SIZE	FMSI NO.	RIVET NO.
E-3495	Dayton/Batco 07115 Meritor A3222V1088	15" x 4"	1308	10-7

MERITOR "STOPMASTER" WEDGE BRAKE PARTS

WEDGE Return Spring

	EUCLID NO.	REPLACES	LENGTH	O. D.	APPLICATION AND GENERAL INFORMATION
	E-1458	Dayton/Batco 07136 Navistar 264621C1 Meritor 2758Q43 Haldex 66447 Haldex C66447 Leland L968	6"	9/16"	For "RS" Brakes and Pre-121 15" "RD" Brakes.
GREEN					
	E-1140	Dayton/Batco 07134 Trailmobile 12608 Trailmobile 16101 Meritor 2258E629 Navistar 266303C1 Navistar 491688C1 Haldex 65385 Haldex 66640 Trailmobile 7-8-34 Trailmobile 700749 Haldex C66425 Leland L1286 Leland L2856 Leland L579	7-3/4"	29/32"	For 15" x 6" and 7" "RD" and Weld-On "RD" Trailer Brakes. Replaces old style blue and green spring.
BLACK					
	E-2476	Dayton/Batco 07137 Meritor 2758W127 Navistar 295610C1 Dayton/Batco 7138 Haldex C66455 Leland L1650	8-3/8"	1"	For Meritor Front Axle Wedge Brake Square Connecting Rod For Application on Cast Spider
YELLOW					
	E-7211	Meritor 2258S1033 Leland L3028	8-35/64"	15/16"	For All 15" "RD" Brakes

BRAKE SHOE CLIP ASSEMBLY

	EUCLID NO.	REPLACES	INCLUDES	APPLICATION AND GENERAL INFORMATION
	E-2522	Dayton/Batco 01391 Dayton/Batco 07121 Meritor 1718D134 Trailmobile 19050 Trailmobile 19079 Trailmobile 19145 Meritor 2257M1001 Haldex 65417 Leland K284 Meritor KIT9020 Leland L1020 Leland L1020(2) Leland L756 Meritor N14 Meritor N15 Meritor S156 Meritor WA14 Meritor WA15 Meritor WA15Z	1 Shoe Clip; 1 Clip Bolt; 1 Washer; 1 Nut	For Drive and Trailer Brakes With Cast Spiders.

MERITOR "STOPMASTER" WEDGE BRAKE PARTS

BRAKE SHOE HOLD DOWN KIT



EUCLID NO.	REPLACES	APPLICATION AND GENERAL INFORMATION
E-3525	Dayton/Batco 07123 Trailmobile 383525 Haldex CQ66744 Leland K112 Leland K26 Leland K26(2) Meritor KIT1129	For RS and RD Brakes with Backing Plates. Includes enough parts to service one wheel.

WEDGE GUIDE



EUCLID NO.	REPLACES	APPLICATION AND GENERAL INFORMATION
E-1262	Dayton/Batco 07900 Meritor 1779Q433 Trailmobile 19065 Navistar 268439C1	Fits end of Air Chamber Push Rod.

COLLET NUT



EUCLID NO.	REPLACES	APPLICATION AND GENERAL INFORMATION
E-1128	Dayton/Batco 07900 Meritor 1727N40 Trailmobile 19249 Navistar 258009C2 Haldex 65391 Leland L764	Attaches Air Chamber to Wedge Housing.

PUSH ROD BOOT KIT



EUCLID NO.	REPLACES	APPLICATION AND GENERAL INFORMATION
E-2290	Dayton/Batco 07909 Trailmobile 382290 Navistar 478888C91 Meritor MPS2003	For Stopmaster OEM Type.

PUSH ROD BOOT



EUCLID NO.	REPLACES	APPLICATION AND GENERAL INFORMATION
E-1735	Dayton/Batco 07907 Trailmobile 19245 Meritor 2760J10 Meritor 2760U21 Meritor MPS2003	For Euclid Bellows Type.

PLUNGER HOUSING



EUCLID NO.	REPLACES	APPLICATION AND GENERAL INFORMATION
E-2193	Dayton/Batco 07260 Meritor 3299C4189 Trailmobile 382193 Leland L1019	Bolt-on Housing for Trailer Brakes with Weld-on Spiders.

EUCLID "HDG" LUBRICANT



EUCLID NO.	REPLACES	APPLICATION & GENERAL INFORMATION
E-2015	Dayton/Batco 07930 Dayton/Batco 07931 Meritor 2297U4571 Bendix 318870 Bendix 322854 Bendix 33003 Trailmobile 382015 Haldex 65473 Meritor A1779W283 Leland L1017	<p>HDG is recommended for all Wedge Brakes. Apply HDG generously to the Plungers and Rollers of the Wedge Assembly and to the inside of the Seal Assembly also. Each can is 6-1/2 oz.</p> <p>HDG is formulated to:</p> <ul style="list-style-type: none"> * Withstand High Temperatures * Be Waterproof * Be Corrosion Resistant * Provide Long Life * Resist Extreme Pressure * Be Smooth In Texture * Have A Thin Film Capacity

MERITOR "STOPMASTER" WEDGE BRAKE PARTS

E-5542 MINOR REPAIR KIT WITHOUT HOLD DOWN KIT

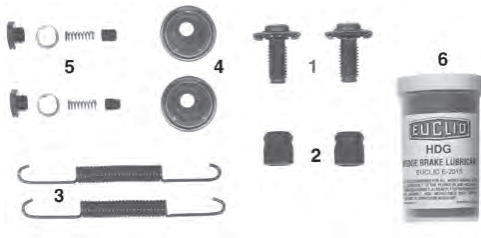

ITEM	QTY.	EUCLID NO.	DESCRIPTION	APPLICATION INFORMATION
1	2	E-3492	Adjusting Bolt	For 15" RS Single Actuated Front Brakes. Services one wheel. REPLACES: E-2147
2	2	E-3499	Adjusting Sleeve	
3	2	E-1458	Return Spring Wedge Brake	
4	2	E-5532	Front Wedge Seal	
5	2	E-5540	Front Pawl Assembly	
6	1	E-2015	Wedge Brake Lubricant	

E-5543 MINOR REPAIR KIT WITH HOLD DOWN KIT

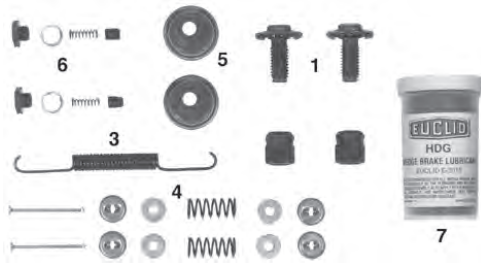

ITEM	QTY.	EUCLID NO.	DESCRIPTION	APPLICATION INFORMATION
1	2	E-3492	Adjusting Bolt	For 15" RS Single Actuated Front Brakes. Services one wheel. REPLACES: Meritor KIT 1191; E-3526
2	2	E-3499	Adjusting Sleeve	
3	1	E-1458	Return Spring Wedge Brake	
4	1	E-3525	Wedge Brake Kit	
5	2	E-5532	Front Wedge Seal	
6	2	E-5540	Front Pawl Assembly	
7	1	E-2015	Wedge Brake Lubricant	

E-7212A MINOR REPAIR KIT WITH 12° WEDGE ASSEMBLIES



ITEM	QTY.	EUCLID NO.	DESCRIPTION	APPLICATION INFORMATION
1	2	E-3994	Seal Assembly	For 15" RD Dual Actuated Brakes. Services one wheel. REPLACES: Meritor KIT 1106B; E-2525A, E-7212.
2	2	E-3995	Seal Assembly	
3	2	E-3997	12 Degree Adjuster Assembly	
4	2	E-2484	Adjusting Bolt	
5	2	E-7211	Brake Return Spring	
6	1	E-2015	Wedge Brake Lubricant	

E-7213A MAJOR REPAIR KIT - LEFT HAND BRAKE WITH 12° WEDGE ASSEMBLIES



ITEM	QTY.	EUCLID NO.	DESCRIPTION	APPLICATION INFORMATION
1	2	E-2484	Adjusting Bolt	For 15" RD Dual Actuated Brakes. Services one wheel. REPLACES: Meritor KIT 9006LHB; E-2524A, E-7213.
2	2	E-3997	12 Degree Adjuster Assembly	
3	2	E-1137	12 Degree LH Plunger	
4	2	E-1128	Air Chamber Collet Nut	
5	2	E-7211	Brake Return Spring	
6	2	E-3994	Seal Assembly	
7	2	E-3995	Seal Assembly	
8	2	E-5541	Anchor Plunger Guide	
9	2	E-1261	12 Degree Wedge Assembly	
10	2	E-2522	Shoe Clip Wedge Assembly	
11	1	E-2015	Wedge Brake Lubricant	

MERITOR "STOPMASTER" WEDGE BRAKE PARTS

E-7214A MAJOR REPAIR KIT - RIGHT HAND BRAKE WITH 12° WEDGE ASSEMBLIES



ITEM	QTY.	EUCLID NO.	DESCRIPTION	APPLICATION INFORMATION
1	2	E-2484	Adjusting Bolt	For 15" RD Dual Actuated Brakes. Services one wheel. REPLACES: Meritor KIT 9006RHB; E-2523A, E-7214
2	2	E-3997	12 Degree Adjuster Assembly	
3	2	E-1136	12 Degree RH Plunger	
4	2	E-1128	Air Chamber Collet Nut	
5	2	E-7211	Brake Return Spring	
6	2	E-3994	Seal Assembly	
7	2	E-3995	Seal Assembly	
8	2	E-5541	Anchor Plunger Guide	
9	2	E-1261	12 Degree Wedge Assembly	
10	2	E-2522	Shoe Clip Wedge Assembly	
11	1	E-2015	Wedge Brake Lubricant	

E-5544 MAJOR REPAIR KIT - LEFT HAND BRAKE WITH 14° WEDGE ASSEMBLIES



ITEM	QTY.	EUCLID NO.	DESCRIPTION	APPLICATION INFORMATION
1	2	E-2484	Adjusting Bolt	For 15" RD Dual Actuated Brakes. Services one wheel.
2	2	E-3998	14 Degree Adjuster Assembly	
3	2	E-2137	14 Degree LH Plunger	
4	2	E-1128	Air Chamber Collet Nut	
5	2	E-7211	Brake Return Spring	
6	2	E-3994	Seal Assembly	
7	2	E-3995	Seal Assembly	
8	2	E-5541	Anchor Plunger Guide	
9	2	E-2141	14 Degree Wedge Assembly	
10	2	E-2522	Shoe Clip Wedge Assembly	
11	1	E-2015	Wedge Brake Lubricant	

E-5545 MAJOR REPAIR KIT - RIGHT HAND BRAKE WITH 14° WEDGE ASSEMBLIES



ITEM	QTY.	EUCLID NO.	DESCRIPTION	APPLICATION INFORMATION
1	2	E-2484	Adjusting Bolt	For 15" RD Dual Actuated Brakes. Services one wheel.
2	2	E-3998	14 Degree Adjuster Assembly	
3	2	E-2136	14 Degree RH Plunger	
4	2	E-1128	Air Chamber Collet Nut	
5	2	E-7211	Brake Return Spring	
6	2	E-3994	Seal Assembly	
7	2	E-3995	Seal Assembly	
8	2	E-5541	Anchor Plunger Guide	
9	2	E-2141	14 Degree Wedge Assembly	
10	2	E-2522	Shoe Clip Wedge Assembly	
11	1	E-2015	Wedge Brake Lubricant	

INDEX

Service Tools	Page
AccuTorq Truck Torque Wrenches.....	2-7
Axle Stud Cone Plier	2-8
Brake Shoe Anchor Pin Press	2-1
Return Spring Removal Tool	2-3
Bushing Removal and Installation Tool	2-2
Clevis Pin Press	2-2
Clutch Adjusting Wrench	2-14
Clutch Handler	2-15
Dual Wheel Puller.....	2-14
Flywheel Handling Attachment.....	2-15
Front End Service Tools	2-12
Heavy-Duty Brake Drum Gauge Kit	2-2
Heavy-Duty Truck Brake Spring Plier	2-1
Roll Pin Punch Tool.....	2-2
Slack Adjuster Pullers	2-2
U-Joint Puller	2-14
Universal Bearing Cup Installer	2-14
Universal Brake Shoe Gauge	2-1
Wheel Bearing Endplay Gauge	2-14
Wrenches for Truck & Trailer Wheels.....	

S.O.S.

Special Order Service

Can't find it? Trouble sourcing parts? Need assistance?

Let Euclid's Special Order Service (S.O.S.) help.

Euclid's position as the market leader provides you access to the products and manufacturers listed below. These entire product lines are available to you by just placing a phone call to Euclid's S.O.S. Department at 866-238-2543 (option 3) in the U.S. or 800-387-3889 in Canada.

AIR BRAKE PARTS

Anchorlok Brake Chambers
Euclid Brake Chambers
Bendix (Allied Signal)
Brake Shoes
Camshafts
Dana
Fruehauf
Haldex

HYDRAULIC BRAKE PARTS

Calipers - New, Remanufactured & Loaded
Clutch Master Cylinders
Clutch Slave Cylinders
Disc Pads
Bendix
Dayton
EIS
Lucas
Master Cylinders
Rotors
Wagner Brake
Wheel Cylinders

FRICITION MATERIAL

Hydraulic Disc Pads
Euclid Stopmate
Performance Friction
Air Brakes Drum
Euclid Friction Material

FRONT END PARTS

King Pin Kits
Tie Rod Ends
Drag Link Ends
Drag Links

SUSPENSION PARTS

Binkley
Cambria
Chalmers
Fruehauf
Hendrickson
Hendrickson Axle Division
Hendrickson Turner
Hutchens
Kwik-Loc (Jifflox)
Meritor
Neway
Reyco/Transpro
Ridewell
Torque Arms
Trailmobile
Full suspensions are available

WHEEL AND HUB PARTS

ConMet
Dayton
Gunita

SHOCK ABSORBERS & AIR SPRINGS

Gabriel Shock Absorbers
Firestone Air Springs

CARGO RESTRAINT

Ancra

TOOLS AND SHOP EQUIPMENT

Fraser Gauge Company
Kent Moore
Ken Tool
OTC (Owatonna Tool Company)
Tiger Tool

AIR BRAKE SERVICE TOOLS

UNIVERSAL BRAKE SHOE GAUGE



ANCHOR PIN GAUGE

- Go/No-Go Gauge For all Meritor and Fruehauf Standard and Quick Change Shoes.

EUCLID E-3863A



BRAKE SHOE IDENTIFICATION

- Helps determine if a brake shoe is made by Fruehauf or Meritor.



E-3863A TOOL

Can also be used to check the stretch of Wedge Brake Shoes. For detailed information, see instruction sheet included with each tool.



WEB ALIGNMENT GAUGE

- Checks straightness of shoe web. (Except Eaton Shoes.)



STRETCH GAUGE

- Checks stretch of all 16 1/2" Eaton, Fruehauf, and Meritor Shoes.

BRAKE SHOE ANCHOR PIN PRESS



EUCLID NO.

APPLICATION INFORMATION

E-2654

A heavy-duty press that easily removes rusted and corroded brake shoe anchor pins without damage to the brake shoe spider. Removes pins up to 1-1/4" diameter. Use with E-6064 set to remove or install Ball Joints. Also used to remove Brake Shoe Anchor Pins and U-Joints.

HEAVY-DUTY TRUCK BRAKE SPRING PLIER



EUCLID NO.

APPLICATION INFORMATION

E-2656

For Wedge Brakes. This heavy-duty truck brake spring plier provides the extra leverage and strength needed for servicing brake springs. Its 26-1/4" length gives the leverage to do the job.

AIR BRAKE SERVICE TOOLS

HEAVY-DUTY BRAKE DRUM GAUGE KIT



EUCLID NO.

DESCRIPTION

APPLICATION INFORMATION

E-9136

Heavy-Duty Brake Drum Gauge Kit

To quickly and easily measure scored, worn or heat-checked brake drums. Includes: Heavy-Duty Brake Drum Gauge, Gauge Calibration Tool, Euclid red hard plastic shell with padded interior to protect the Brake Drum Gauge.

Measures any brake drum from 12" to 18" diameter in 1/4" increments. Both end tips of gauge are made with hardened steel balls inserted at contact points for accuracy and service. Easy-to-adjust slide bar shows exact drum diameter to be checked.



E-9139

Brake Lining/Block Thickness Gauge

Simplifies checking standard and oversized brake lining. Readings can be recorded in either percentages or linear measure.

SLACK ADJUSTER PULLERS

EUCLID NO.

SLACK TYPE

APPLICATION INFORMATION

E-9319

Manual

Eases the job of removing frozen slack adjusters. Available for Manual and Automatic Slack Adjusters. Slack Pullers have only one moving part and require only a wrench to use them. There are only four simple steps to follow to use the tools:

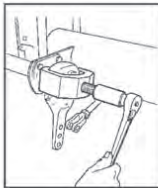

E-9320

Automatic

1. Remove the grease fittings from the slack adjuster.
2. Slide the puller onto the slack adjuster body.
3. Turn the bolt on the puller. The bolt is self-aligning for quick positioning.
4. Catch the slack adjuster as it comes off the camshaft.

CLEVIS PIN PRESS



EUCLID NO.

APPLICATION INFORMATION

E-3379

10,000 lb. capacity press shears cotter pin and pushes out

ROLL PIN PUNCH TOOL



EUCLID NO.

APPLICATION INFORMATION

E-2098

Designed to remove E-626 Roll Pins. The smaller end will pilot in the roll pin and prevent punch from slipping.

BUSHING REMOVAL AND INSTALLATION TOOL



EUCLID NO.

APPLICATION INFORMATION

E-1362

Use to remove or install 1-1/4" I.D. press-in anchor pin bushings.

E-1250

Use to remove or install 1-1/2" I.D. press-in type camshaft bushings.

E-2739

Use to remove or install 1-5/8" I.D. press-in type camshaft bushings.

HYDRAULIC BRAKE SERVICE TOOLS

Return Spring REMOVAL TOOL for LUCAS BRAKE

2

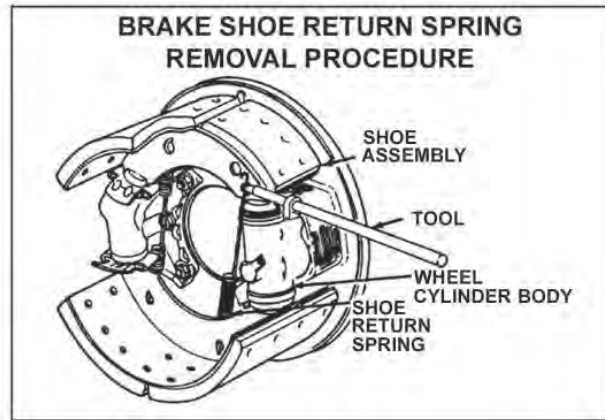
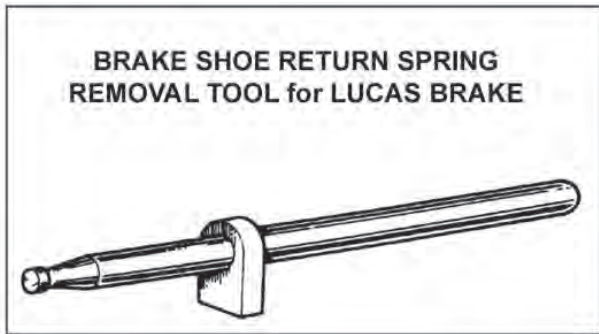

EUCLID NO.

E-6061

APPLICATION & GENERAL INFORMATION

1. Insert the end of the bar into the loop on one of the shoe return springs.
2. Using the wheel cylinder body as a fulcrum, unhook the spring from the shoe web.
3. Support the lower shoe, unhook the second spring, and remove the shoes.

NOTE: The shoe return spring is hooked on the backside of the shoe web. Be careful not to damage the manual adjustment wheel or the rubber dust boot.

TRUCK WHEEL BEARING LOCK-NUT WRENCH ASSORTMENTS

6 PT. WRENCH ASSORTMENT

EUCLID E-7651

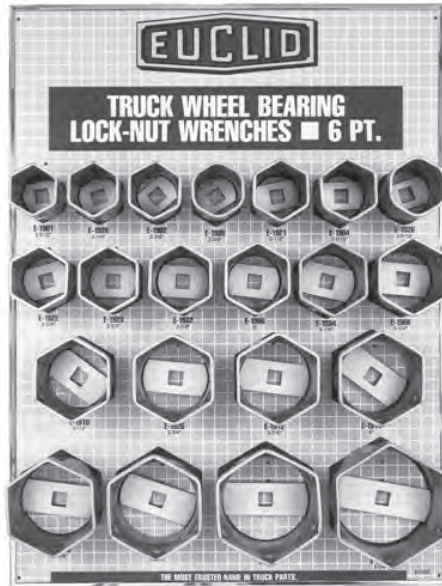

WHEEL BEARING LOCK-NUT WRENCHES WITH *FREE* DISPLAY BOARD

Included with Display Board are one each
of the 21 Wrenches listed:

EUCLID NO.	OPENING SIZE	EUCLID NO.	OPENING SIZE	EUCLID NO.	OPENING SIZE
E-1901	2-3/32"	E-1922	2-5/8"	E-1926	3-3/4"
E-1920	2-1/4"	E-1923	2-3/4"	E-1912	3-7/8"
E-1902	2-3/8"	E-1932	2-7/8"	E-1914	4"
E-1936 ¹	2-3/8"	E-1906	3"	E-1915	4-1/8"
E-1921	2-1/2"	E-1934	3-1/8"	E-1916	4-3/8"
E-1904	2-9/16"	E-1908	3-1/4"	E-1918	4-7/8"
E-1928 ¹	2-9/16"	E-1910	3-1/2"	E-3371	5-1/4"

Display Board only E-7652 (Board Size: 24" Wide x 32" High)

8 PT. WRENCH ASSORTMENT

EUCLID E-7653

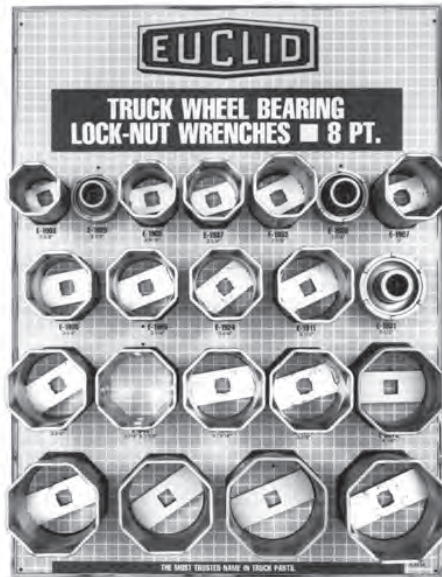

WHEEL BEARING LOCK-NUT WRENCHES WITH *FREE* DISPLAY BOARD

Included with Display Board are one each
of the 20 Wrenches listed:

EUCLID NO.	OPENING SIZE	EUCLID NO.	OPENING SIZE	EUCLID NO.	OPENING SIZE
E-1903	2-3/8"	E-1935	3-1/8"	E-1913	3-7/8"
E-1929 ²	2-1/2"	E-1909	3-1/4"	E-3372	4-1/8"
E-1937	2-3/4"	E-1924	3-3/8"	E-1917	4-3/8"
E-1905	2-9/16"	E-1911	3-1/2"	E-6137	4-1/2"
E-1933	2-7/8"	E-1931 (2)	3-1/2"	E-1597A	4-13/16"
E-1930 ²	2-7/8"	E-1925	3-3/4"	E-1919	4-7/8"
E-1907	3"	E-1927	3-13/16"		

Display Board only E-7654 (Board Size: 24" Wide x 32" High)

¹ Fits special "rounded" hex nuts found on Dana Axles of some Ford Trucks.
² Tubular Spanner Wrenches

WHEEL BEARING LOCK-NUT WRENCHES

Euclid wrenches have a 3/4" drive square opening for use with an extension and torque wrench to tighten the Lock-Nut as required. A longer extension can be used for wide rims. Wrenches are made of high strength and heavy-duty gauge steel...Resists rounding out.



HOW TO DETERMINE THE WRENCH SIZE YOU NEED.....

Using a caliper or other suitable measuring device, determine the size of the Lock-Nut. Consult the chart at right to select the Lock-Nut wrench of corresponding size.

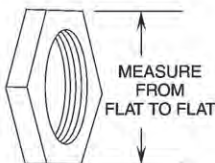

Listed by Opening Size

EUCLID NO.	OPENING SIZE	EUCLID NO.	OPENING SIZE
E-1901	2-3/32" (6 pt.)	E-1909	3-1/4" (8 pt.)
E-1920	2-1/4" (6 pt.)	E-1924	3-3/8" (8 pt.)
E-1902	2-3/8" (6 pt.)	E-1910	3-1/2" (6 pt.)
E-1936 ¹	2-3/8" (6 pt.)	E-1911	3-1/2" (8 pt.)
E-1903	2-3/8" (8 pt.)	E-1926	3-3/4" (6 pt.)
E-1921	2-1/2" (6 pt.)	E-1925	3-3/4" (8 pt.)
E-1904	2-9/16" (6 pt.)	E-1927	3-13/16" (8 pt.)
E-1928 ¹	2-9/16" (6 pt.)	E-1912	3-7/8" (6 pt.)
E-1905	2-9/16" (8 pt.)	E-1913	3-7/8" (8 pt.)
E-1922	2-5/8" (6 pt.)	E-1914	4" (6 pt.)
E-1923	2-3/4" (6 pt.)	E-1915	4-1/8" (6 pt.)
E-1937	2-3/4" (8 pt.)	E-3372	4-1/8" (8 pt.)
E-1932	2-7/8" (6 pt.)	E-1916	4-3/8" (6 pt.)
E-1933	2-7/8" (8 pt.)	E-1917	4-3/8" (8 pt.)
E-1906	3" (6 pt.)	E-6137	4-1/2" (8 pt.)
E-1907	3" (8 pt.)	E-1597A	4-13/16" (8 pt.)
E-1934	3-1/8" (6 pt.)	E-1918	4-7/8" (6 pt.)
E-1935	3-1/8" (8 pt.)	E-1919	4-7/8" (8 pt.)
E-1908	3-1/4" (6 pt.)	E-3371	5-1/4" (6 pt.)

NEW STYLE EUCLID TUBULAR SPANNER WRENCHES WITH 3/4" DRIVE SQUARE OPENING

May be used with Torque Wrench for use on Chevrolet Truck Axles

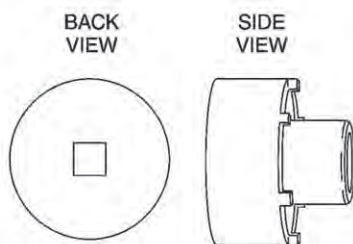
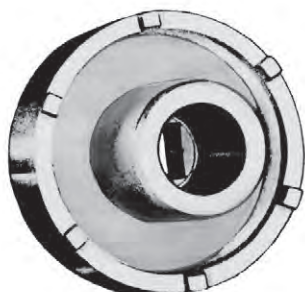

EUCLID NO.	APPLICATION	USED WITH NUT SIZE & PART NO.
E-1929 ²	1946 thru current Chevrolet 5, 200 & 7, 200 lb. Axles	2"-16 THD. GM 3663657
E-1930 ²	1954 thru current Chevrolet 11,000 & 13,500 lb. Axles	2-1/8"-16 THD. GM 473636
E-1931	1954 thru current Chevrolet 15,000 lb. Axles 1965 thru current Chevrolet 15,000 trailing Axle 1966 thru current Chevrolet 17,000 lb. 2-speed Axle	2-1/2"-16 THD. GM 3703711

EUCLID TUBULAR SPANNER WRENCHES USED WITH THIS STYLE NUT.

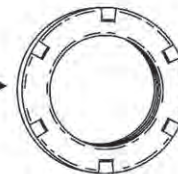

¹ Fits special "rounded" hex nuts found on Dana Axles of some Ford Trucks.
² Tubular Spanner Wrenches

WHEEL BEARING LOCK-NUT WRENCHES



EUCLID E-1597A HEAVY-DUTY SPINDLE NUT WRENCH

For Fruehauf "Pro-Par" Spindle Nuts
and Hub Caps

New design is made of high strength heavy 5/32" gauge steel to resist rounding out, splitting and twisting.

8 point, 4-13/16" across flats, 2-7/8" deep.
3/4" square drive opening allows for the use of a torque wrench and extensions.

Replaces: Fruehauf ACC-005963-900

ONE WRENCH USED FOR BOTH

E-04075
HUB CAP



E-2550
SPINDLE NUT

AXLE SPINDLE SERVICE TOOLS

UNIVERSAL OUTSIDE THREAD CHASER

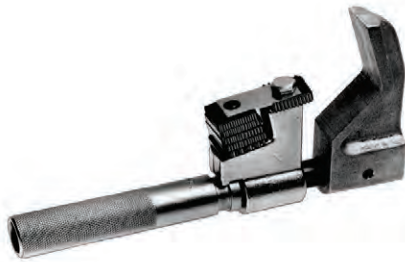

EUCLID E-2644

Restores threads to their original condition. Eliminates the need for expensive thread cutting equipment. OPERATION: Tighten the tool slightly on the good threads, then back off over the damaged thread area to restore the threads. The aluminum alloy V Pad will not damage the threads. Capacity from 1-1/4" to 5" O.D.

Complete with 6 dies - Threads per inch 4, 5, 6, 7, 7-1/2, 8, 9, 10, 11, 11-1/2, 12, 14, 16, 18, 20, and 24.

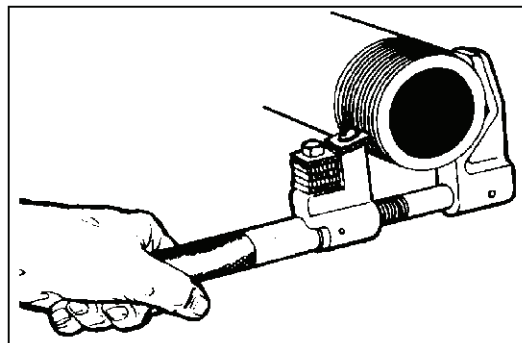

BRAKE DRUM DOLLY

ALLOWS ONE PERSON TO EASILY REMOVE, TRANSPORT AND REPLACE TRACTOR/TRAILER BRAKE DRUMS.



EUCLID E-9436

For Class 7 and 8 tractor/trailer brakes
Handles 15" and 16-1/2" drums
5" height adjustment
37" to 55" telescoping handle
Ball bearing wheels
Pneumatic tires
Rugged steel construction
Replaces: OTC No. 5017

WHEEL SERVICE TOOLS

FOR USE WITH 1" DRIVE AIR IMPACT WRENCH ONLY

AccuTorq Truck Torque Wrenches Designed to Help Prevent Overtightening Wheel Nuts

- * For use with 1" air impact wrenches
- * For 1 1/4" to 1 1/2" hex truck wheel nuts
- * For 13/16" square head inner cap nuts
- * Covers a torque of 475 ft. lbs.

How Does AccuTorq Work? When the wheel nut is tightened to the maximum torque indicated on the AccuTorq wrench, the socket stops moving forward. Strobe marks on the socket end of the wrench visually indicate when the socket has stopped turning. This is possible because the shaft of the AccuTorq wrench acts as a torsion bar and starts to wind when the impact wrench tries to overtighten the wheel nut. When the hammer inside the impact wrench rotates for the next impact, the AccuTorq shaft unwinds. As a result, the socket end of the AccuTorq wrench stops turning while the drive end advances, then retreats with each impact of the impact wrench. The wheel nut is not tightened any further.

AccuTorq wrenches must be used with the impact wrench size indicated in order to assure proper accuracy. Use of extensions or reducers will reduce accuracy of AccuTorq wrenches. Do not hold the AccuTorq wrench's shaft while in use, or the effect of the tool will be dampened. AccuTorq wrenches are accurate to plus or minus 15% of the stated maximum torque limit.



**Buy 3 of the most popular Truck AccuTorq®
Drives and get the Rack
FREE from EUCLID.**

EUCLID PART NO. CONTAINS ONE EACH
E-11051

E-3909 Brown	1" Drive-33mm Hex	475 Ft. Lbs.
E-3910 Black	1" Drive-1-1/2" Hex	475 Ft. Lbs.
E-3911 Yellow	1" Drive-13/16" Square	475 Ft. Lbs.



EUCLID NO.	COLOR	SOCKET SIZE	MAXIMUM TORQUE LIMIT
E-3910	BLACK	1-1/2" Hex	475 ft. lbs.
E-11003	RED	1-1/4" Hex	250 ft. lbs.
E-3909	BROWN	1-5/16" Hex	475 ft. lbs.
E-3911	YELLOW	13/16" Square (for Inner Cap Nuts)	475 ft. lbs.

NOTE: Will work for both left and right hand thread.

WHEEL SERVICE TOOLS

AXLE STUD CONE PLIER

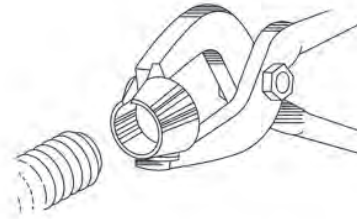

EUCLID NO.	APPLICATION
E-2655	A specially designed cone plier to give the leverage needed to expand and remove the tapered cone from rear axle studs without damaging the stud threads. Expands tapered cone to speed axle disassembly on medium-size and heavy-duty truck axles.

WRENCHES FOR TRUCK & TRAILER WHEELS

Made from Forged Chrome Nickel Alloy Steel - All Wrenches 16" Long

EUCLID NO.	DESCRIPTION	APPLICATION
E-5850	Universal Wrench for Disc Wheels	1-1/2" Hex and 13/16" Sq. for Budd, Chevrolet, GMC, Motor Wheel, Inner and Outer Nuts. 1-1/8" Hex for GMC and Chevrolet Flanged Nuts.
E-5851	Chevrolet Dual Wheels	1" and 1-1/4" Hex with 5/8" Sq. Sockets.
E-5854	Hex Handle for Wrenches	3/4" Hex x 22" Long fits all of the above wrenches., 3/4" hex x 22" long. Fits all of the above wrenches.
E-5855	Disc Outer Nut Wrench	1-1/2" Hex - Holds outer nut while turning inner nut.
E-5856	Dayton - Guinite - Erie - Webb Spoke Wheels	1-1/16" and 1-1/4" Hex for 5/8"-11 and 3/4"-10 Nuts.
E-6038	Hub-Piloted Wheels	24 mm and 33 mm Hex for Metric Wheel Nuts.

SPECIAL TOOLS

STUD SETTER FOR INSTALLING SPOKE WHEEL STUDS



EUCLID NO.	FOR STUD SIZE	THREAD
E-5833	5/8"	USS
E-5834	3/4"	COARSE

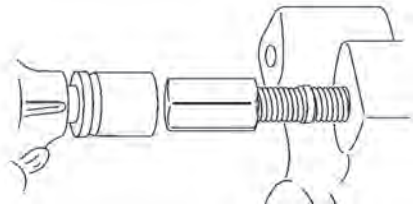

The only other tool needed is an impact wrench with 1-1/8" and 1-1/4" sockets or 4-way wrench.

GEAR TYPE POWER DRIVE WRENCH FOR USE ON ALL TRUCK AND ROAD EQUIPMENT

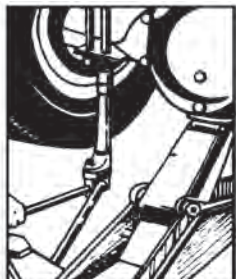
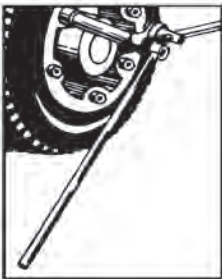
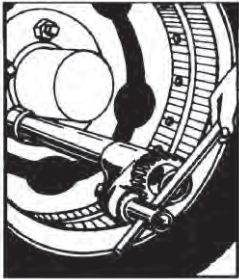

3 to 1 POWER RATIO

For Budd inner & outer nuts and other type wheel nuts, u-bolts, head bolts, etc.

For complete wrench assembly as shown, order
EUCLID E-5857

- Includes:
- 1 Power Drive
- 1 20" Bar
- 1 36" Tube Handle
- 1 3/4" Service Adapter
- 1 13/16" Adapter for Square Budd Nut



ADAPTER
EUCLID E-5859

1-1/2" hex to 13/16" square for Budd inner nuts

BROKEN CAP NUT AND STUD REMOVAL TOOL

3 TOOLS FOR THE PRICE OF 1!

One tool kit replaces three tools for the same cost as one tool.

EUCLID KIT E-5205

ECONOMICAL VALUE

Eliminates the need to buy an entire new tool when teeth wear.
Replace ONLY the rib nut at a fraction of the cost of other removal tools.

EUCLID

NO.	DESCRIPTION	INCLUDES
E-5205	Broken Stud and Cap Nut Removal Kit	1 E-5206 1-1/8" Rib Nut
		1 E-5207 3/4" Rib Nut
		1 E-5208 5/8" Rib Nut
		1 Drive-On Tool



EUCLID

NO.	DESCRIPTION	APPLICATION
E-5206	1-1/8" Replacement Rib Nut	For removing broken 1-1/8" Inner Cap Nuts
E-5207	3/4" Replacement Rib Nut	For removing broken 3/4" Wheel Studs
E-5208	5/8" Replacement Rib Nut	For removing broken 5/8" Wheel Studs

WARRANTY

The teeth of the rib nuts will wear out after limited use. Therefore, rib nuts are not covered under Euclid's Warranty Policy.

SUSPENSION SERVICE TOOLS

TOOL FOR INSTALLING HUTCHENS, TRAILMOBILE AND TRANSPRO EQUALIZER BUSHINGS

EUCLID E-2130



3-3/4" O.D. x 3-3/8" I.D. x 3-1/2" Long

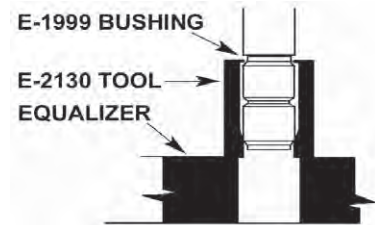

Tool automatically centers bushing for perfect alignment and ease of installation. Use to uninstall E-1999A, E-3394A, and E-4827 Bushings.

TORQUE ARM BUSHING INSTALLATION TOOL



EUCLID E-1600

For Hutchens
Torque Arms

Use to install E-934
Bushing in original
equipment Hutchens
Torque Arms

2-1/2" O.D. x 1-5/16" I.D. x 2-1/2" Long

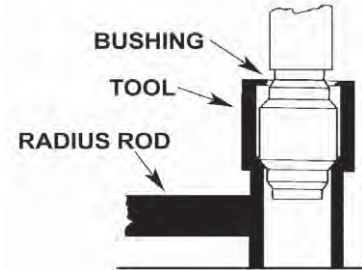

EUCLID E-2652 For Euclid Torque Arms

Tool for installing E-934, E-1980, and E-1061 Torque Arm Bushings in Euclid Torque Arms. Tapered Counter Bore automatically centers bushing for perfect alignment and compression.

UNIVERSAL OUTSIDE THREAD CHASER

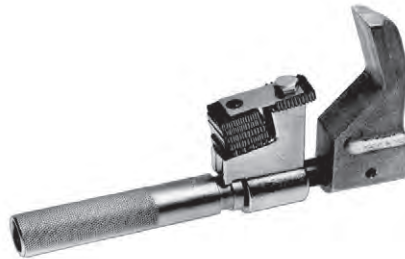

EUCLID E-2644

Restores threads to their original condition. Eliminates the need for expensive thread cutting equipment. OPERATION: Tighten the tool slightly on the good threads, then back off over the damaged thread area to restore the threads. The aluminum alloy V Pad will not damage the threads. Capacity from 1-1/4" to 5" O.D.

Complete with 6 dies - Threads per inch 4, 5, 6, 7, 7-1/2, 8, 9, 10, 11, 11-1/2, 12, 14, 16, 18, 20, and 24.

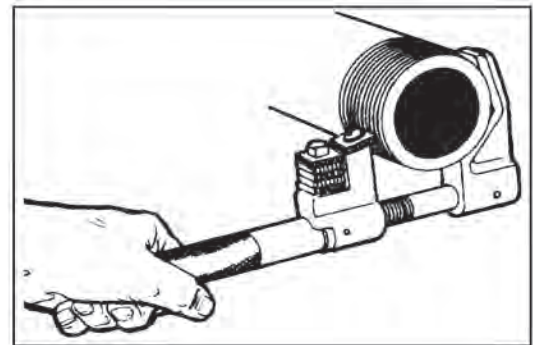

BEAM END BUSHING INSTALLATION TOOL

EUCLID E-9575



Replaces Hendrickson S-21307

For installing Tri-Functional Bushings used in Hendrickson T, HT, Intraax, and HLM Suspensions with an impact wrench.

Does not include bushing.

FRONT END SERVICE TOOLS

EUCLID NO.	DESCRIPTION	APPLICATION
E-2654	Ball Joint and Anchor Pin Press	A heavy-duty press that easily removes rusted and corroded brake shoe anchor pins without damage to the brake shoe spider. Removes pins up to 1-1/4" diameter. Use with E-6064 set to remove or install Ball Joints. Also used to remove Brake Shoe Anchor Pins and U-Joints.
E-6064	Ball Joint Service Set	Includes: 3" x 3-3/4" I.D. Receiver Tube; 2-1/2" O.D. x 2-1/4" I.D. Receiver Tube; 2" O.D. x 1-3/4" I.D. Receiver Tube; Installation Adapter; Removal Adapter. Requires use of an E-2654 Ball Joint Press.
E-6065	Ball Joint Spanner Wrench	For removal and installation of Ball Joint Adjusting Sleeves on 1/2, 3/4 and 1-Ton Dana open yoke front axles used on Ford, GMC, Navistar and Jeep 4WD vehicles. Allows torquing with 1" socket for proper upper Ball Joint preload.
E-6066	Ball Joint Separator	Ball Joint Separator is designed solely to remove Ball Joints from spindle support arms without damaging other components.
E-6067	Multi-Purpose Separator	This tool can be used to remove camber adjustment sleeves on Ford 4 x 2 and 4 x 4 light trucks where the camber is adjustable. It can also be used as a Pitman Arm wedge for Light-Duty Trucks as well as a Tie Rod Separator for Medium and Heavy-Duty Trucks.
E-6068	Pitman Arm Puller	Pitman Arm Pullers are designed to handle the toughest Pitman Arm pulling job. Pullers are adjustable and have special forged jaws shaped to fit the job. "Pullers have two clamp bolts that lock jaws on the Pitman Arm for pulling, assuring positive grip and leaving hands free for the pulling job." Light-Duty Trucks - 1 Ton only
E-6069	Pitman Arm Puller	Pitman Arm Pullers are designed to handle the toughest Pitman Arm pulling job. Pullers are adjustable and have special forged jaws shaped to fit the job. "Pullers have two clamp bolts that lock jaws on the Pitman Arm for pulling, assuring positive grip and leaving hands free for the pulling job." Light-Duty Trucks to 3/4 Ton

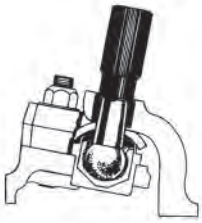

15/16" Fork Spread, 16" Long



1 7/16" Fork Spread, 11 5/8" Long



FRONT END SERVICE TOOLS



1 1/8" Fork Spread, 11" Long

EUCLID NO. DESCRIPTION APPLICATION

E-6070 Pitman Arm Wedge Removes Pitman Arms on Light-Duty Trucks. Wedge end is placed between parts and a few hammer blows separate them.



1 1/16" Fork Spread, 11" Long

E-6071 Shock Absorber Link and Tie Rod End Separator Separates Shock Absorber Links and Tie Rod Ends.



E-6072 Tie Rod Adjusting Tool For Light-Duty Trucks with 1-1/8" diameter adjusting sleeves. Allows 360 degree rotation of the adjusting sleeve where space is limited. 1/2" square drive for ratchet or breaker bar.



E-6073 Control Arm Bushing Service Set Removes worn Upper Control Arm Bushings and installs new ones without damage to the control arm. Includes C-Frame Press and all adaptors and inserts necessary to do the job correctly.



E-6074 Dial Indicator Set Use to gauge suspension looseness. Has a 2-1/4" diameter dial face graduated to .001 inch, a flexible arm to get at hard-to-reach areas and an on/off magnetic base.

MISCELLANEOUS SERVICE TOOLS

WHEEL BEARING ENDPLAY GAUGE

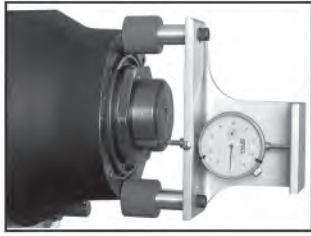

EUCLID NO.

APPLICATION

E-9793

- Quick and Accurate:
1. Remove magnet keepers and attach to face of trailer hub with indicator contacting end of the spindle.
 2. Zero dial by rotating the dial face.
 3. Rock the hub and drum to determine bearing endplay.
 4. Adjust bearing endplay and recheck.

U-JOINT PULLER



EUCLID NO.

APPLICATION

E-6039

Works on most Dana Spicer and Meritor U-joints. Designed for use with a 1/2" air impact wrench. Can be used at different angles and in tight places. Holes in the puller legs store bolts.

Bolts included are: (2) 5/16"-24 x 1-1/2"; (2) 3/8"-24 x 1-1/2"; (2) 7/16 in-20 x 1-1/2"; (2) M8 x 1.25mm x 35mm

UNIVERSAL BEARING CUP INSTALLER



EUCLID NO.

APPLICATION

E-6040

Designed for installing wheel bearing cups of tractor and trailer wheels from 11,000 to 50,000 lbs. capacity. Adjust from 3-5/8" to 6-1/2" dia. bearing cup.

To Use:

1. Adjust and lock the jaws to the cup I.D.
2. Slip on new cup and put it in place in the wheel.

DUAL WHEEL PULLER



EUCLID NO.

CAPACITY

CASTER INFO.

FLOOR SPACE

LIFT TRAVEL

TILT ADJUSTMENT

APPLICATION

E-9433

1,500 lbs.

3-1/2" Swivel

45" x 41"

4-3/4"

4 Degrees

Allows one person to easily remove, transport and replace dual wheel and tire assemblies. 6 ft. chain and hydraulic jacking mechanism with handle included. Replaces OTC No. 1770A

FLYWHEEL HANDLING ATTACHMENT



EUCLID NO.

APPLICATION

E-9435

Attaches to E-9434 Clutch Handler for removal of flywheels (including pot type). Replaces OTC No. 218174.

MISCELLANEOUS SERVICE TOOLS

CLUTCH HANDLER



EUCLID NO.	LIFTING RANGE	CLUTCH SIZE
E-9434	9" to 37"	15-1/2"

APPLICATION
 Allows one person to easily remove, transport and replace clutch disc plate or flywheel (with attachment).
 Parallel lift path allows precise alignment, 4 swivel casters and 2" spline shaft aid alignment. Integral hydraulic jacking mechanism. Use of E-9435 flywheel attachment permits removal of flywheels (including pot type).
 Replaces OTC No. 5015

2

CLUTCH ADJUSTING WRENCH



EUCLID NO.
E-6041

APPLICATION

For Spicer heavy-duty clutches. Designed for internal adjustment of angle spring and multiple-lever clutches.

Literature on Demand available at meritor.com

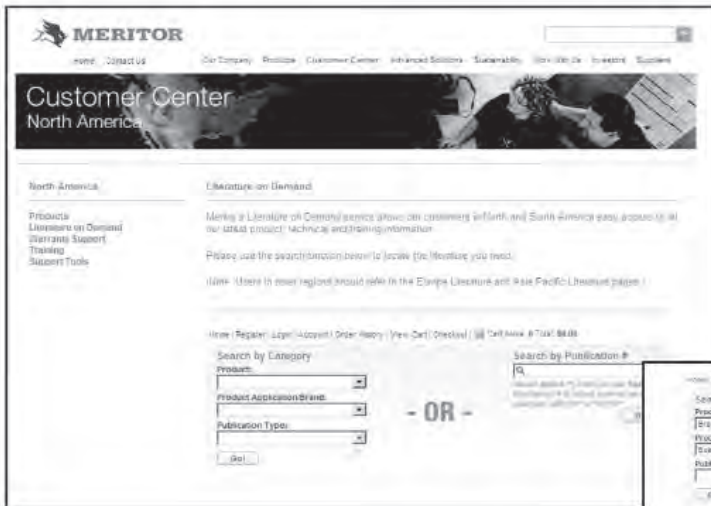

1. Visit the Customer Center at meritor.com

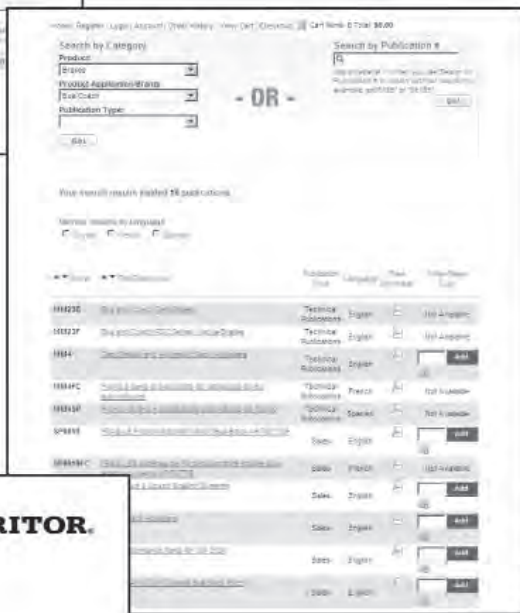

2. Search for a publication -
parts book, sales flier or technical publication



3. Select format - electronic or print

For additional product, technical and training information, contact your nearest product sales team,

INDEX

Miscellaneous Parts	Page
Junction Box.....	3-2
Fifth Wheel Parts.....	3-1
Placard Holder	3-2
Trailer King Pin.....	3-1

E-700 TRAILER KING PIN

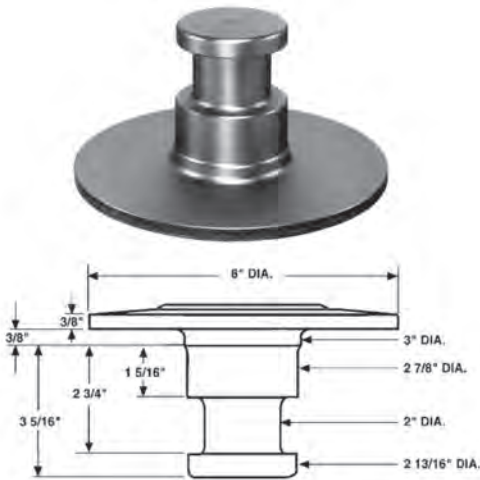

EUCLID NO.	REPLACES	FLANGE DIAMETER	APPLICATION AND GENERAL INFORMATION
E-700	Dayton/Batco 110212 Dana/Spicer 482201 Sirco 700 Holland Hitch KP-AAR-880 Holland Hitch KPT809F Meritor R30700	8"	Various applications with Weld-On King Pins. For 3/8" thick plate.



EUCLID NO.	REPLACES	APPLICATION AND GENERAL INFORMATION
E-702A-KA	Dayton/Batco 11098 Tramec 59000 Trailmobile 70099206 Sirco 702 Holland Hitch GL0303010 Fruehauf MFAKLOCK900	King pin lock. For keyed alike. S.O.S. only. Sold in lots of 8.
E-702A		King pin lock

FIFTH WHEEL PARTS



EUCLID NO.	REPLACES	MATERIAL	CONTAINS	APPLICATION INFORMATION
E-9569		Polyurethane	(2) E-7450 Bushing, (2) E-9568 Pin	Fifth Wheel Bushing and Pivot Pin Assembly for Holland



EUCLID NO.	REPLACES	MATERIAL	O.D.	I.D.	LENGTH	DESCRIPTION
E-7450	Meritor R307450 Holland Hitch XB00112	Polyurethane	2-1/4"	1-1/8"	4-1/4"	Fifth Wheel Bushing
E-8927	Dayton/Batco 329105U Meritor R308927 Holland Hitch XB00122	Polyurethane	2-1/4"	1-7/16"	4-1/4"	Fifth Wheel Bushing
E-8652	Holland Hitch 1471301 Holland Hitch 16049 Dayton/Batco 329139U Meritor R308652	Polyurethane	2-1/2"	1-1/2"	4-1/4"	Fifth Wheel Bushing
E-7451	Holland Hitch 16045 Dayton/Batco 329123U Dayton/Batco 329124U Meritor R307451 Holland Hitch XA16045	Polyurethane	2-3/4"	1-1/8"	4-1/4"	Fifth Wheel Bushing



JUNCTION BOX



EUCLID NO.	DESCRIPTION	REMARKS
E-10158	Universal 7-Terminal Junction Box	Precision molded cover and body. Five possible slot openings. Five each open and closed grommets. Molded terminal block.

PLACARD HOLDER



EUCLID NO.	DESCRIPTION	REMARKS
E-9868	Placard Holder - Aluminum	Constructed from corrosion resistant, die-stamped aluminum. Pre-punched holes for riveting to trailer walls. Stainless steel snap fastener holds placard securely in place. Sized for 10-3/4" x 10-3/4" slide-in placards.
E-9868W	Placard Holder - White	Constructed from corrosion resistant, die-stamped aluminum. Pre-punched holes for riveting to trailer walls. Stainless steel snap fastener holds placard securely in place. Sized for 10-3/4" x 10-3/4" slide-in placards. Outside dimension 12-1/2" x 14-1/8". Molded drainage outlet. Packaged 25 per carton.

REBUILD KITS FOR HORTON FAN CLUTCHES



EUCLID NO.	CLUTCH DIAMETER	DESCRIPTION	REPLACES HORTON	CLUTCH MODELS
E-824100	7-1/2"	Upgrade Kit (less hub and friction disc)	None	590XXX, 790XXX, 980XXX, 990XXX
E-824104		With assembled hub and friction disc	994307	
E-824101		Upgrade Kit (less hub and friction disc)	None	
E-824105	9-1/2"	With assembled hub	994315	591XXX, 791XXX, 981XXX, 991XXX
E-824106		With assembled hub and friction disc	994305	
E-824102	All	Seal Kit	994205	

Features



Angular Contact Bearing

The angular contact bearing is precision ground and designed to carry both radial and axial loads for the fan blade weight and thrust. All angular contact bearings are packed in a high temperature synthetic grease for maximum bearing life.



Air Plunger Valve

The air plunger valve is impregnated with graphite carbon for self lubrication and maximum heat. The mating metal air seal is machine ground to tolerances that virtually eliminate air leaks.



Non-asbestos Friction Linings

Non-asbestos friction linings are manufactured for high heat and maximum fan blade horsepower to maintain optimum cooling. With proper air pressure, the linings have virtually no slipping or glazing.



Precision Cut Spacers

Precision cut spacers extend the life of the fan clutch and reduce breakdown and maintenance by reestablishing OE tolerances within the fan clutch.

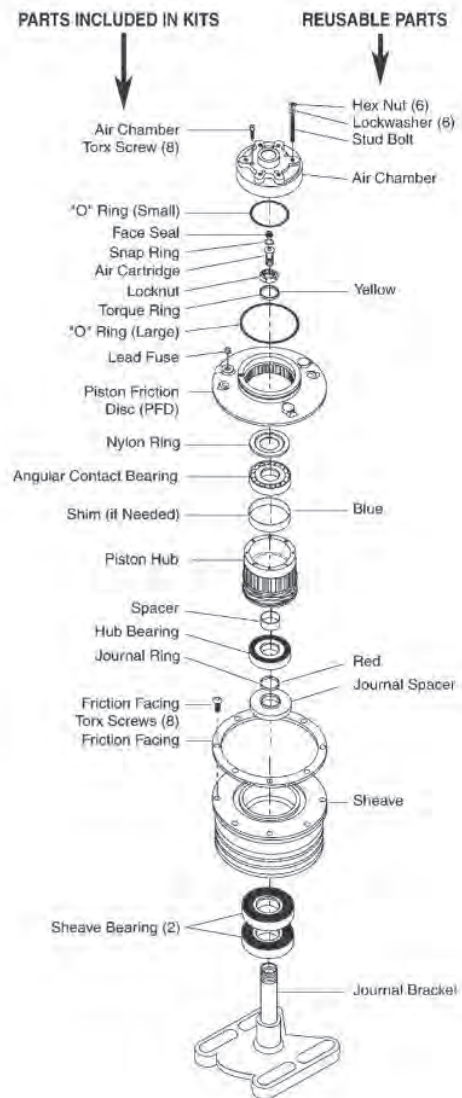

COMPETITOR INTERCHANGE

BENDIX		BENDIX (cont)		BENDIX (cont)	
COMPETITOR NUMBER	EUCLID NUMBER	COMPETITOR NUMBER	EUCLID NUMBER	COMPETITOR NUMBER	EUCLID NUMBER
023969	E-1495	278232	E-2668	296010N	E-153200
049624	E-1493	278288	E-2760	316331	E-1486
100140	E-2157	278295	E-2763	316349	E-1218
100144	E-2159	278302	E-4904S	316354	E-1216
100150	E-2746	278312	E-612S-BK	316355	E-1217
100151	E-2746	278321	E-940S-BK	316356	E-1215
101207	E-2458HD	278323	E-612S-BK	316367	E-1497
101214	E-2459HD	278323N	E-612S-BK	316368	E-1496
101214N	E-2459HD	278326	E-940S-BK	316370	E-2162
101215	E-2458HD	278326N	E-940S-BK	316392	E-1497
101215N	E-2458HD	278719	E-612HD	316997	E-1489
101883	E-5498	279946	E-2668	316998	E-1489
102111/12	E-6923B	279946N	E-2668	317071	E-1214
102111/12	E-6936	279947	E-2669	317166	E-6924B
10211112	E-6923B	279947N	E-2669	318564	E-1230
10211112	E-6936	283411	E-1574S-BK	318598	E-2154
102115/16	E-6924B	283411	E-1574HD	318599	E-2155
10211516	E-6924B	285783	E-2153	318601	E-2156
102117/18	E-6927B	285784	E-2154	318657	E-2281
10211718	E-6927B	285785	E-2155	318658	E-1214
103345	E-2458S-BK	285786	E-2156	318870	E-2015
104623	E-7232	286740	E-2459HD	319114	E-2158
104624	E-7232	286965	E-2458S-BK	3200070	E-2153
104624	E-7238	286965	E-612HD	3200449	E-2156
104627	E-7231	286965N	E-2458S-BK	3200709	E-2154
104628	E-7237	286965N	E-612HD	3200710	E-2155
104631	E-7235	287899	E-2459HD	322854	E-2015
127808	E-2125	288753	E-2459S-BK	324095	E-2745
222812	E-612HD	288753N	E-2459S-BK	324095N	E-2745
224293	E-612HD	289305	E-6907A	324330	E-1214
2259428	E-7230	289312/13	E-6925B	324756	E-1218
2259450	E-7236	28931213	E-6925B	33003	E-2015
22810	E-940HD	28931213	E-6942	445280	E-2552
23969	E-1495	289313	E-6925B	445342	E-2282
249940	E-2161	289313	E-6942	445343	E-2281
249941	E-2162	289314/15	E-6927B	49624	E-1493
249942	E-2163	289314/15	E-6944	55656	E-10865
249943	E-2164	28931415	E-6927B	806380	E-5482
27323	E-612HD	28931415	E-6944	815806	E-6925B
277959	E-940S-BK	289654/55	E-6924B	H1110	E-1493
278008	E-6113	289654/55	E-6940	H1110DP	E-1493
278008	E-940HD	28965455	E-6924B	H1132	E-1495
278010	E-612HD	28965455	E-6940	H1456	E-4078
278010	E-612HD	289741/42	E-6923B	H994204	E-824100
278010N	E-612HD	289741/42	E-6936	H994205	E-824102
278016	E-6113	28974142	E-6923B	H994206	E-824101
278016	E-940HD	28974142	E-6936	CREWSON BRUNNER	
278016N	E-940HD	289748/49	E-6924B	COMPETITOR	EUCLID
278045	E-612HD	289748/49	E-6940	NUMBER	NUMBER
278045N	E-612HD	28974849	E-6924B	21123	E-10950A
278084	E-2091	28974849	E-6940	22123	E-10949A
278231	E-2669	296010	E-153200	8110	E-9132

COMPETITOR INTERCHANGE

CREWSON BRUNNER (cont)		CREWSON BRUNNER (cont)		DANA/SPICER (cont)	
COMPETITOR NUMBER	EUCLID NUMBER	COMPETITOR NUMBER	EUCLID NUMBER	COMPETITOR NUMBER	EUCLID NUMBER
8120	E-9133	CI25300	E-6990A	10384BULK	E-6109
8125	E-9135	CI34100	E-10784A	10392	E-2760
8410KT	E-11883	CI34200	E-11880	10392BULK	E-2760
8410KTA	E-11881	CI35100	E-11877	10393	E-2763
8415KT	E-11884	CI35200	E-11879	10393BULK	E-2763
8420KT	E-11882	CI41100	E-10780A	10399	E-4904S
8420KTA	E-11890	CI41101	E-11872	10854	E-940S-BK
8425KT	E-11885	CI41106	E-10782A	10WJ165	E-504
CA1200	E-612S-BK	CI42100	E-10779A	11004	E-1269
CA1202	E-940S-BK	CI42101	E-11873	11004	E-1426
CA1296	E-2091	CI42106	E-10781A	11004	E-537
CA2200	E-2458S-BK	CI43100	E-11875	11005	E-563
CA2202	E-2459S-BK	CI43106	E-10783A	11006	E-538
CA2296	E-5498	CI71100	E-10786A	11007	E-503
CA3206	E-1574S-BK	CI71106	E-10789A	11008	E-536
CA4201	E-4904S	CI72100	E-10785A	11009	E-656
CA4202	E-4904S	CI72106	E-10788A	11019	E-661
CB21102	E-6992A	CI73106	E-10787A	11090	E-502
CB21103	E-6991A	DANA/SPICER		11093	E-512
CB21123	E-10950A	COMPETITOR	EUCLID	110A	E-2157
CB22102	E-6994A	NUMBER	NUMBER	11109	E-2517
CB22103	E-6993A	10012	E-2307	111A	E-2158
CB22123	E-10949A	10351	E-612S-BK	11227	E-1880B
CB23102	E-6996A	10351	E-612HD	11227	E-545A
CB23106	E-6995A	10351BULK	E-612S-BK	11228	E-747
CB24100	E-6987A	10351HD	E-612HD	11229	E-539
CB24102	E-6987A	10353	E-2091	11230	E-2241
CB24300	E-6988A	10353BULK	E-2091	11238	E-1424A
CB25100	E-6989A	10354	E-940S-BK	11238	E-556
CB25102	E-6989A	10354	E-940HD	11239	E-1425A
CB25300	E-6990A	10354BULK	E-940S-BK	11239	E-557
CB34100	E-10784A	10354HD	E-612HD	11351	E-6991A
CB41100	E-10780A	10354HD	E-940HD	11354	E-6992A
CB41106	E-10782A	10355	E-2458S-BK	11355	E-6993A
CB42100	E-10779A	10355BULK	E-2458S-BK	11367	E-6995A
CB42106	E-10781A	10355HD	E-2458HD	11368	E-6994A
CB43106	E-10783A	10358	E-2668	11369	E-6996A
CB71100	E-10786A	10358BULK	E-2668	11399	E-6987A
CB72100	E-10785A	10359	E-2669	11401	E-6989A
CB72106	E-10788A	10359BULK	E-2669	114A	E-2159
CB73106	E-10787A	10366	E-940HD	11508	E-1808
CI21102	E-6992A	10367	E-1574S-BK	11509	E-2176
CI21103	E-6991A	10367	E-1574HD	11509	E-500
CI21153	E-10950A	10367HD	E-1574HD	11527	E-1106
CI22102	E-6994A	10368	E-2459S-BK	11528	E-1025
CI22103	E-6993A	10368BULK	E-2459S-BK	11528	E-2101
CI22153	E-10949A	10368HD	E-2459HD	11593	E-1410
CI23102	E-6996A	10379	E-1574S-BK	11594	E-1411
CI23103	E-6995A	10379BULK	E-1574S-BK	12052	E-1107
CI24100	E-6987A	10383	E-6110	120A	E-7214A
CI24300	E-6988A	10383BULK	E-6110	12195	E-5097
CI25100	E-6989A	10384	E-6109	12196	E-5096

COMPETITOR INTERCHANGE

DANA/SPICER (cont)		DANA/SPICER (cont)		DANA/SPICER (cont)	
COMPETITOR NUMBER	EUCLID NUMBER	COMPETITOR NUMBER	EUCLID NUMBER	COMPETITOR NUMBER	EUCLID NUMBER
121A	E-7213A	142A	E-1816S	17416	E-10906
12200	E-773	143A	E-1816S	17417	E-10905
122A	E-7212A	143ABULK	E-1816S	17418	E-10908
1308585931	E-5528	144A	E-1816SHD	17419	E-10907
1308E	E-5126	144ABULK	E-1816SHD	17460	E-5495
1308E931	E-5126	14A	E-1816HD	17461	E-5494
1308T	E-3439	14A	E-1816SHD	17462	E-5497
13451	E-1901	15525	E-512	17463	E-5496
13452	E-1902	15525	E-512S	17472	E-9060
13453	E-1903	15527	E-1112A	17473	E-9059
13454	E-1904	15529	E-609	17480	E-3855
13455	E-1905	15531	E-503	17481	E-3854
13456	E-1906	15532	E-2119	17482	E-3857
13457	E-1907	15532	E-502	17483	E-3856
13458	E-1908	15536	E-3711	17484	E-6885
13459	E-1909	15536	E-3711S	17485	E-6884
13460	E-1910	15537	E-2390	17500	E-3855
13461	E-1911	15538	E-2029	17500	E-5525
13462	E-1912	15540	E-1403	17501	E-3854
13463	E-1913	15541	E-1337	17501	E-5524
13464	E-1914	15542	E-2766S	17502	E-3857
13465	E-1915	15543	E-2773	17502	E-5527
13466	E-1916	15550	E-3424	17503	E-3856
13467	E-1917	15554	E-3445	17503	E-5526
13468	E-1918	15557	E-2798	17504	E-5519
13469	E-1919	15560	E-608	17505	E-5518
13470	E-1920	16393	E-9710	17506	E-6104
13471	E-1921	16394	E-9709	17506	E-9728
13472	E-1922	16395	E-4716	17507	E-6103
13473	E-1923	16396	E-4717	17507	E-9727
13474	E-1924	163A	E-1816S	17508	E-5521
13475	E-1925	16407	E-4885	17509	E-5520
13476	E-1926	16408	E-4884	17510	E-9099
13477	E-1927	16469	E-4712	17511	E-9098
13478	E-1928	16470	E-4713	17512	E-5523
13479	E-1932	16524	E-3854	17513	E-5522
13480	E-1933	16561	E-920	17514	E-9101
13481	E-1934	16561	E-920S	17515	E-9100
13485	E-1935	16562	E-919	17516	E-5517
13486	E-1936	16563	E-1893	17517	E-5516
13487	E-1937	16564	E-2389	17518	E-6102
13488	E-1929	16565	E-1893	17519	E-6101
13489	E-1930	16565	E-1893S	17522	E-9730
13490	E-1931	16617	E-4714A	17523	E-9729
13495	E-1597A	16618	E-4715A	17536	E-9740
13497	E-2644	16655	E-6885	17537	E-9739
13503	E-2655	16656	E-6884	17554	E-6104
13504	E-2654	171A	E-2121	17555	E-6103
13505	E-2656	17402	E-10902	17556	E-9742
13A	E-1816S	17403	E-10901	17557	E-9741
141A	E-1816HD	17414	E-10904	17560	E-9710
142A	E-1816HD	17415	E-10903	17561	E-9709

COMPETITOR INTERCHANGE

DANA/SPICER (cont)		DANA/SPICER (cont)		DANA/SPICER (cont)	
COMPETITOR NUMBER	EUCLID NUMBER	COMPETITOR NUMBER	EUCLID NUMBER	COMPETITOR NUMBER	EUCLID NUMBER
17568	E-2794	17618	E-4891	17722	E-5509
17569	E-2795	17619	E-4890	17723	E-5508
17570	E-4712	17619	E-4891	17724	E-5511
17571	E-4713	17620	E-1564	17725	E-5510
17572	E-4714	17621	E-1563	17734	E-9264
17572	E-4714A	17622	E-2099	17735	E-9263
17573	E-4715	17622	E-2100	17736	E-9752
17573	E-4715A	17623	E-2099	17737	E-9751
17574	E-1094	17626	E-2442B	17-738	E-9274
17575	E-1095	17627	E-2441B	17-739	E-9273
17576	E-686	17628	E-2444B	17782	E-9760
17577	E-687	17629	E-2443B	17783	E-9759
17578	E-2412	17630	E-2446B	17810	E-2442B
17578	E-2412A	17631	E-2445B	17811	E-2441B
17578	E-688	17632	E-2450A	17812	E-2444B
17578	E-688A	17633	E-2449A	17813	E-2443B
17579	E-2413	17634	E-2694	17814	E-2446B
17579	E-2413A	17635	E-2693	17815	E-2445B
17579	E-689	17636	E-4720	17826	E-11859
17579	E-689A	17637	E-4721	17914	E-9732
17580	E-1424A	17638	E-4722	17915	E-9731
17581	E-1425A	17639	E-4723	17920	E-9734
17581	E-557	17640	E-2448A	17921	E-9733
17582	E-684	17641	E-2447A	17924	E-11857
17583	E-685	17642	E-2451A	17925	E-11856
17584	E-690	17643	E-2452A	17926	E-11859
17584	E-9090	17648	E-2792	17927	E-11858
17585	E-691	17649	E-2793	17928	E-9736
17585	E-9089	17658	E-5509	17929	E-9735
17586	E-1094	17659	E-5508	17930	E-10910
17586	E-4716	17660A	E-5511	17931	E-10909
17587	E-1095	17661A	E-5510	17936	E-11861
17587	E-4717	17662	E-5495	17937	E-11860
17588	E-2796	17663	E-5494	17940	E-9738
17589	E-2797	17664	E-5497	17941	E-9731
17590	E-7218	17665	E-5496	17941	E-9737
17591	E-7217	17682	E-1393	17946	E-11863
17592	E-7220	17683	E-1394	17947	E-11862
17593	E-7219	17684	E-1410	18500	E-9646
17594	E-4884	17685	E-1411	18501	E-9645
17594	E-4885	17690	E-1422	18502	E-9648
17595	E-4884	17691	E-1423	18503	E-9647
17595	E-4885	17694	E-1420	18504	E-9650
17596	E-4718	17695	E-1421	18505	E-9649
17597	E-4719	17698	E-2492	18508	E-9654
17598	E-690	17699	E-2493	18509	E-9653
17599	E-691	17700	E-3517	18510	E-9656
17610	E-4893	17701	E-3516	18511	E-9655
17611	E-4892	17714	E-4901	18516	E-9660
17616	E-3862	17715	E-4900	18517	E-9659
17617	E-3861	17720	E-5507	18518	E-9662
17618	E-4890	17721	E-5506	18519	E-9661

COMPETITOR INTERCHANGE

DANA/SPICER (cont)		DANA/SPICER (cont)		DANA/SPICER (cont)	
COMPETITOR NUMBER	EUCLID NUMBER	COMPETITOR NUMBER	EUCLID NUMBER	COMPETITOR NUMBER	EUCLID NUMBER
18520	E-9664	18772	E-5134	18839	E-9675
18521	E-9663	18773	E-5133	18842	E-1089
18522	E-9666	18774	E-5136	18843	E-1090
18523	E-9665	18775	E-5135	18848	E-4992
18528	E-9672	18776	E-5063	18849	E-4991
18529	E-9671	18777	E-5062	18850	E-9652
18530	E-4732A	18781	E-9677	18851	E-9651
18531	E-4733A	18786	E-4703B	18852	E-2714A
18532	E-4732A	18787	E-4702B	18853	E-2715A
18533	E-4733A	18800	E-4705B	18854	E-5056
18534	E-9676	18801	E-4705B	18855	E-5057
18535	E-9675	18801	E-4707B	18856	E-3461
18536	E-9678	18802	E-4706B	18857	E-3460
18537	E-9677	18803	E-4707B	18857	E-3461
18538	E-9680	18804	E-2478B	18858	E-4917
18539	E-9679	18805	E-2479B	18859	E-4916
18542	E-9684	18806	E-2700B	18860	E-9648
18543	E-9683	18807	E-2701B	18861	E-9647
18724	E-9690A	18808	E-1773C	18864	E-9654
18-724	E-9690A	18809	E-1774C	18865	E-9653
18725	E-9689A	18810	E-1147C	18866	E-9664
18-725	E-9689A	18811	E-1148C	18867	E-9663
18726	E-2799	18812	E-4708B	18868	E-9668
18727	E-2800	18813	E-4709B	18869	E-9667
18734	E-4886	18818	E-4710B	18870	E-4913
18734	E-4887	18819	E-4711B	18871	E-4912
18735	E-4886	18820	E-9672	18872	E-4919
18735	E-4887	18821	E-9671	18873	E-4918
18736	E-9766	18822	E-4732A	18874	E-4937
18738	E-1775	18822	E-9674A	18875	E-4936
18739	E-1776	18823	E-4733A	18-876	E-9704
18740	E-2786	18823	E-9673A	18-877	E-9703
18741	E-2787	18824	E-9650	18880	E-4996
18742	E-4740	18825	E-9649	18881	E-4995
18743	E-4740	18826	E-9656	18882	E-4994
18743	E-4741	18828	E-9656	18883	E-4993
18746	E-3523	18828	E-9658	18885	E-4997
18747	E-3524	18829	E-9655	18892	E-9708
18747	E-9765	18829	E-9657	18893	E-10863
18748	E-4888	18830	E-9660	18896	E-5530
18748	E-4889	18830	E-9660	18897	E-5529
18749	E-4888	18831	E-9659	18900	E-9712
18749	E-4889	18831	E-9659	18901	E-9711
18761	E-5058	18832	E-9662	18930	E-5505A
18762	E-5130	18833	E-9661	18931	E-5504A
18763	E-5129	18834	E-9676	18936	E-9065
18766	E-5061	18835	E-9675	18937	E-9065
18767	E-5060	18836	E-9669	18940	E-5491
18768	E-5067	18836	E-9670	18941	E-5490
18769	E-5066	18837	E-9669	18942	E-5493
18770	E-5132	18837	E-9670	18943	E-5492
18771	E-5131	18838	E-9676	18944	E-9772

COMPETITOR INTERCHANGE

DANA/SPICER (cont)

COMPETITOR NUMBER	EUCLID NUMBER
18945	E-9771
18-948	E-9704
18-949	E-9703
18972	E-9031
18973	E-9030
18982	E-5493
18983	E-5492
18984	E-9770
18985	E-9769
18A	E-2121HD
192A	E-1607HD
19852	E-545A
19853	E-1880B
19853	E-1880S
19853A	E-3490B
19854	E-1428A
19854	E-1428S
19856	E-2768
19857	E-2101
19858	E-1025
19859	E-1418
19860	E-2767
19862	E-2398
19862	E-757
19863	E-1583
19864	E-1402
19864	E-1420
19865	E-3512
19866	E-1400
19870	E-752
19874	E-2475
19875	E-2785
19876	E-2804
19877	E-2805
19878	E-543
19882	E-3481A
19883	E-3228
19884	E-980
19890	E-979
19891	E-2770
19892	E-2724
19893	E-2725
19894	E-2726
19895	E-3437
19896	E-3437
19902	E-3872
19903	E-3873
19910	E-9643
19912	E-2177
19913	E-9069
19915	E-10197
19921	E-4800

DANA/SPICER (cont)

COMPETITOR NUMBER	EUCLID NUMBER
19922	E-5122
19923	E-5123
19A	E-1607HD
201144	E-5500
202103206L	E-5096
202103206R	E-5097
20881	E-747
20882	E-2399
20883	E-2109
20886	E-2684
21850	E-5480
21852	E-7236
21853	E-7230
21855	E-5503
21860	E-2686
21870	E-5092
21872	E-4902
21873	E-3491
21877	E-5126
21878	E-3304
21883	E-5303A
21885	E-3417
21886	E-2684
21887	E-2241
21889	E-2241
21894	E-2685
21895	E-2685
21898	E-2778
21899	E-6075
21900	E-3920
21900	E-6075
21900A	E-3920
21902	E-5239
21903	E-5239
21904	E-3522
21914A	E-5500
21915	E-2801
21918	E-3713
21919	E-3714
21920	E-1777
21922E	E-1778
21923	E-2819
21926	E-2474
21929	E-1580
21930	E-1398
21931	E-2393
21931	E-2393A
21932	E-2394
21933	E-1139
21935	E-2689
21938	E-1457
21942	E-1489

DANA/SPICER (cont)

COMPETITOR NUMBER	EUCLID NUMBER
21966	E-2712
21968	E-2728
21969	E-2729
21970	E-3438
21971	E-3439
21972	E-2687
21973	E-3303
21978	E-5528
21979	E-4785
21980	E-2729
2291283	E-3469
231026	E-541
231027	E-1808
231029	E-530
241056	E-797X
241057	E-636X
241058	E-583X
241059	E-633X
241060	E-634X
241061	E-917X
241062	E-918X
241065	E-798X
241066	E-628X
241067	E-635X
241A	E-1887ASHD
241ABULK	E-1887ASHD
241AF	E-3801
24A	E-1887ASHD
24ABULK	E-1887ASHD
25A	E-2820
26A	E-2821
271191	E-2517
271192	E-2517
271194	E-1577A
271195	E-2102
271196	E-2695
271197	E-2361
271198	E-1571
271199	E-1385
271200	E-535
271203	E-3859
271208	E-1314
27A	E-5499
281231	E-807
281232	E-759
281233	E-536
281234	E-667
281235	E-943
281236	E-943
281237	E-1567
281238	E-2690A
281239	E-662

COMPETITOR INTERCHANGE

DANA/SPICER (cont)		DANA/SPICER (cont)		DANA/SPICER (cont)	
COMPETITOR NUMBER	EUCLID NUMBER	COMPETITOR NUMBER	EUCLID NUMBER	COMPETITOR NUMBER	EUCLID NUMBER
281240	E-2407	291315	E-910	311405	E-4739
281241	E-2408	291318	E-1408	311406	E-4935
281243	E-2670	291319	E-2404	311430	E-4934A
281244	E-536	291320	E-1781	311A	E-4880S
281246	E-712	291321	E-1782	311A	E-4880SHD
281248	E-961	291322	E-1565	31624	E-801
281252	E-2380	291325	E-3473	321425	E-523
281253	E-1271	291326	E-2409	321426	E-781
281255	E-2291	291327	E-2411A	321427	E-586
281257	E-661	291330	E-3476	321428	E-2177
281258	E-602	291331	E-2733	321429	E-1406
281260	E-2551	291333	E-3472	321430	E-1582
281261	E-2716	291334	E-3475	321431	E-2672
281262	E-2732	291335	E-3477	321435	E-500
281263	E-3447	291336	E-3474	321436	E-505
281264	E-5127	291337	E-3473	321437	E-2111A
281267	E-1272	291338	E-3471	321438	E-2176
281275	E-2406	291339	E-3478	321440	E-501
281A	E-2769S	291341	E-656	321441	E-2217A
281A	E-4515Q-N	291344	E-5137	321441	E-595
281ABULK	E-2769S	291345	E-3479	32144114	E-796
281ABULK	E-4515Q-N	291346	E-5138	32144118	E-795
281AR	E-2769S	291A	E-2769SHD	321442	E-596A
281AR	E-4515Q-N	291A	E-4515QHD-N	321443	E-2802
281ARBULK	E-2769S	291ABULK	E-2769SHD	321444	E-2803
281ARBULK	E-4515Q-N	291ABULK	E-4515QHD-N	321445	E-2395
28A	E-2769HD	291AR	E-2769SHD	321446	E-2396
28A	E-4515QHD-N	291AR	E-4515QHD-N	321458	E-3511
291266	E-1416A	291ARBULK	E-2769SHD	321460	E-1305
291267	E-1272	29A	E-2769HD	321461	E-1304
291269	E-1416	29A	E-4515QHD-N	321463	E-3421A
291270	E-654	29XL	E-5515	321464	E-3421A
291271	E-2405	301347	E-2103	321465	E-3421A
291274	E-2405	301357	E-2104	321467	E-3483
291275	E-2406	301358	E-1318A	321468	E-3482
291280	E-1314	301361	E-1319A	321471	E-5477
291281	E-654	301362	E-603	326514	E-11981
291282	E-2717	301364	E-4586	331477	E-886
291283	E-3469	301368	E-2477B	331478	E-886
291285	E-5128	301373	E-2447A	331493	E-2807
291301	E-526	301373	E-2477B	331499	E-3775
291302	E-1569	301373A	E-2447A	341525	E-801
291303	E-3234	301375	E-3859	341526	E-527
291305	E-910	301381	E-6076	341527	E-2392
291306	E-2720	301391	E-4587	341528	E-538
291307	E-580	301392	E-4586	341529	E-539
291308	E-581	301398	E-4594	341530	E-3227
291309	E-564	301399	E-4593	341531	E-1581
291310	E-656	30A	E-6999S	341532	E-3007A
291311	E-719	30AR	E-6999S	341535	E-1106
291312	E-2411A	311401	E-4737A	341536	E-1107
291314	E-2734	311402	E-4738A	341539	E-579A

COMPETITOR INTERCHANGE

DANA/SPICER (cont)		DANA/SPICER (cont)		DANA/SPICER (cont)	
COMPETITOR NUMBER	EUCLID NUMBER	COMPETITOR NUMBER	EUCLID NUMBER	COMPETITOR NUMBER	EUCLID NUMBER
341540	E-773	437031	E-2469	4515QBULK	E-2778
341541	E-1307	437031	E-2526	4515X3	E-3920
341542	E-1308	437032	E-2287	4515X3BULK	E-3920
341544	E-2401	437033	E-2469	4524P	E-2687
341545	E-937	437033	E-2526	4524Q	E-3303
341546	E-3975	437034	E-2086B	4536FC2	E-10762
341547	E-5093	437035	E-2086B	4536P	E-2393A
341550	E-2723	437035	E-2287	4536S	E-2393
341552	E-3427	437036	E-1357A	4536S	E-2393A
341558	E-714	437037	E-2282	455	E-2728
341561	E-3871	437037	E-2382	4551P	E-5239
341562	E-3874	437037A	E-3520A	4551Q	E-3522
341563	E-4736	437038	E-2122	4551XFL	E-3713
341565	E-3513	437039	E-2090	4551XFR	E-3714
341570	E-5478	437040	E-2494	458	E-2729
341A	E-3710S	437041	E-2125	4591S	E-2394
341A	E-3710SHD	437042	E-2089	4595E	E-2712
341A	E-4515X	437042	E-2123	459SE	E-2712
341ABULK	E-3710S	437043	E-2696A	45A	E-2403HD
341ABULK	E-4515X	437043A	E-2696A	4602RW	E-1139
34A	E-3710HD	437044	E-2088A	4602S	E-1139
34A	E-3710SHD	437044	E-2088AHD	4605B	E-1489
34A	E-4515XHD	437044A	E-2363	4615RW	E-2689
34ABULK	E-3710SHD	437046	E-2679A	4670FT	E-2394
34ABULK	E-4515XHD	437046	E-2679AHD	4670Q	E-3491
351576	E-537	437046A	E-2679A	4692FC	E-5303A
351577	E-563	437047	E-3993B	4692FC2	E-10763
351578	E-671	437048	E-3993B	4692P	E-2394A
351579	E-537	437050	E-3468A	4707R	E-5503
351580	E-1113	437051	E-3446	4707XT	E-5503
351581	E-2391	437059	E-3876	4709E	E-5480
351582	E-1269	437060	E-5140	4709ETN	E-5480
3607	E-3234	437061	E-3354	47A	E-3782
361645	E-957	437062	E-5307	482201	E-700
361647	E-957	437064	E-7235	5003718	E-1107
361653	E-1108	437068	E-9053	5005395	E-773
361657	E-632	437069	E-5501	502A	E-2740
38038	E-910	437071	E-9078HD	511033	E-6000A
38A	E-3895S	437072A	E-6078	511A	E-4691
38A	E-3895SHD	437115	E-10897	511A	E-6879
38A	E-4515U	437118	E-11910	511AK	E-4800
405106	E-667	437118	E-9790A	512	E-2729
40A	E-2126	43A	E-2402HD	512	E-4785
41A	E-2286	44A	E-3484	521A	E-4692
426	E-2729	4514P	E-2684	531A	E-3291
4284P	E-5500	4514Q	E-3304	54A	E-5139
42A	E-2030HD	4515F	E-2685	55A	E-1308Q
4311E	E-1778	4515FBULK	E-2685	55A	E-3869
4311EBULK	E-1778	4515FQ	E-6075	585	E-3439
4317E	E-1777	4515P	E-2241	585ST	E-5528
437029	E-2087	4515PBULK	E-2241	60A	E-2713
437030	E-2680	4515Q	E-2778	6261	E-864

COMPETITOR INTERCHANGE

DANA/SPICER (cont)		DANA/SPICER (cont)		DANA/SPICER (cont)	
COMPETITOR NUMBER	EUCLID NUMBER	COMPETITOR NUMBER	EUCLID NUMBER	COMPETITOR NUMBER	EUCLID NUMBER
631A	E-10244	HK49125	E-3374HD	M10KY105	E-9790A
631A	E-10244S	HK50	E-4691	M10LK105X	E-2030HD
631A	E-5481A	HK51	E-4691	M10SS100	E-501
632A	E-5481A	HK52	E-4692	M10SS100	E-719
63A	E-5481A	HK53	E-2713	M10WJ100	E-2517
64A	E-2769HD	HK54	E-5139	M10WJ102	E-1808
68A	E-3518	HK55	E-1308Q	M10WJ107	E-2102
70A	E-7231	HK55	E-3869	M10WJ108	E-2390
711A	E-7237	HK57	E-2740	M10WJ115	E-1025
80A	E-9070	HK61	E-10244	M10WJ115	E-2101
81A	E-9644	HK61SD	E-10244	M10WJ116	E-2396
82A	E-5086	HK61XLS	E-10244	M10WJ118	E-2398
95A	E-11747	HK62	E-5481A	M10WJ118	E-757
974642	E-11980	HK62XLS	E-10760	M10WJ119	E-2399
E4515U	E-4515U	HK63	E-5481A	M10WJ135	E-1880B
HK14SD	E-1816HD	HK63XLS	E-5481A	M10WJ135	E-545A
HK14XLS	E-1816HD	HK68	E-3518	M10WJ135	E-757
HK14XLS	E-1816S	HK70	E-7231	M10WJ138	E-2389
HK17XLS	E-2121	HK71	E-7237	M10WJ150	E-5305
HK17XLS	E-2121HD	HK72	E-9048	M10WJ151	E-5304
HK24XLSHM	E-2820	HK74XLS	E-3895SHD	M10WJ154	E-544
HK24XLSHM	E-3801	HK77	E-3869	M10WJ155	E-1025
HK24XLSLM	E-1887AHD	HK80XLS	E-9070	M10WJ159	E-502
HK26	E-2821	HK81XLS	E-9644	M10WJ160	E-503
HK27	E-5499	HK95XLS	E-11747	M10WJ162	E-512
HK29	E-2769HD	HK97XLS	E-11981	M10WJ164	E-609
HK29	E-2769S	M10HD100	E-2111A	M10WJ165	E-504
HK29	E-4515QHD-N	M10HD100	E-2176	M10WJ178	E-661
HK29	E-4515Q-N	M10HD100	E-500	M10WJ182	E-602
HK29	E-6999S	M10HD101	E-2395	M10WJ183	E-2389
HK29BULK	E-2769HD	M10HH134	E-654	M10WJ212X	E-2102
HK29SD	E-2769HD	M10HM130	E-579A	M10WR119	E-612S-BK
HK29XLS	E-2769HD	M10HM136	E-2391	M10WR119	E-612HD
HK29XLS	E-4515QHD-N	M10HN136	E-2391	M12KY100	E-2526
HK31XLS	E-4880S	M10HN139	E-564	M12KY101	E-2469
HK32SD	E-5515	M10HN152	E-656	M12KY202	E-2469
HK34SD	E-3710HD	M10HN153	E-563	M12LK101X	E-2402HD
HK34XLS	E-3710HD	M10HN154	E-1106	M12WH112	E-2103
HK34XLS	E-3710S	M10HP102	E-1112A	M12WH112X	E-2103
HK34XLS	E-4515X	M10HP103	E-2029	M12WK10011	E-9744
HK38	E-3895S	M10HP104	E-1112A	M12WK10016	E-9746
HK38	E-4515U	M10HR102	E-527	M12WK10017	E-1422
HK40	E-2126	M10HR104	E-2392	M12WK10018	E-2792
HK43XLS	E-2402HD	M10HR105	E-2401	M12WK10019	E-1420
HK44XLS	E-3484	M10HR119	E-1269	M12WK10019	E-2793
HK45XLS	E-2030HD	M10HR119	E-1426	M12WK10022	E-9748
HK45XLS	E-2403HD	M10HR119	E-537	M12WK10111	E-9743
HK47XLS125	E-3782	M10HR123	E-538	M12WK10116	E-9745
HK47XLS150	E-9283	M10HS115	E-2404	M12WK10117	E-1423
HK47XLS-150	E-10875	M10HS117	E-2409	M12WK10118	E-2793
HK48XLS125	E-3373HD	M10KY100	E-2680	M12WK10119	E-1421
HK48XLS150	E-9281	M10KY105	E-11910	M12WK10122	E-9747

COMPETITOR INTERCHANGE

DANA/SPICER (cont)

DANA/SPICER (cont)

DANA/SPICER (cont)

COMPETITOR NUMBER	EUCLID NUMBER
M12WK1061	E-9744
M12WK10610	E-1422
M12WK10611	E-1420
M12WK10613	E-9748
M12WK1063	E-5096
M12WK1063	E-5097
M12WK1066	E-1410
M12WK1071	E-9743
M12WK10710	E-1423
M12WK10711	E-1421
M12WK10713	E-9747
M12WK1073	E-5096
M12WK1073	E-5097
M12WK1076	E-1411
M12WK1077	E-9745
M12WKL10163	E-9263
M12WKL10175	E-9751
M12WKL10182	E-9749
M12WKL10191	E-9265
M12WKL10206	E-9267
M12WKL10214	E-9269
M12WKL10222	E-9271
M12WKL10233	E-9273
M12WKL10236	E-9275
M12WKL10241	E-9277
M12WKL10264	E-9279
M12WKL20205	E-9753
M12WKL20214	E-9755
M12WKL20222	E-9757
M12WKL20233	E-9759
M12WKL25206	E-10901
M12WKL25214	E-10903
M12WKL25233	E-10905
M12WKL25241	E-10907
M12WKR10163	E-9264
M12WKR10175	E-9752
M12WKR10182	E-9750
M12WKR10191	E-9266
M12WKR10206	E-9268
M12WKR10214	E-9270
M12WKR10222	E-9272
M12WKR10233	E-9274
M12WKR10236	E-9276
M12WKR10241	E-9278
M12WKR10264	E-9280
M12WKR20205	E-9754
M12WKR20214	E-9756
M12WKR20222	E-9758
M12WKR20233	E-9760
M12WKR25206	E-10902
M12WKR25214	E-10904
M12WKR25233	E-10906

COMPETITOR NUMBER	EUCLID NUMBER
M12WKR25241	E-10908
M12WL10233	E-9274
M12WR101	E-2091
M12WR10233	E-9273
M12WS122X	E-2393
M12WS127	E-2394
M12WS129X	E-5303A
M12WS149X	E-5303A
M12WS166X	E-10763
M12WS173X	E-10762
M16D106	E-9789
M16HD100	E-667
M16HD100	E-807
M16HD102	E-530
M16HD102	E-541
M16HH100	E-1416
M16KY100	E-2287
M16LK103X	E-1816HD
M16LK103X	E-1816S
M16LK104X	E-1607HD
M16TF101	E-864
M16WB100	E-886
M16WB101	E-3775
M16WB101	E-886
M16WH101X	E-2104
M16WH113X	E-2104
M16WHR50L	E-9787A
M16WHR50R	E-9788A
M16WJ100	E-2768
M16WJ100	E-3490B
M16WJ101	E-2767
M16WJ102	E-747
M16WJ103	E-539
M16WJ104	E-2177
M16WJ104	E-523
M16WJ105	E-2766S
M16WJ114	E-586
M16WJ121	E-1582
M16WK10012	E-2796
M16WK10210	E-2795
M16WK10212	E-688
M16WK10212	E-688A
M16WK10213	E-2413A
M16WK10217	E-1424A
M16WK10217	E-556
M16WK10219	E-684
M16WK10223	E-4884
M16WK10225	E-1094
M16WK10226	E-4717
M16WK10229	E-7217
M16WK1025	E-9709
M16WK1027	E-4713

COMPETITOR NUMBER	EUCLID NUMBER
M16WK10283	E-2797
M16WK10288	E-4719
M16WK1029	E-686
M16WK10310	E-2794
M16WK10312	E-689
M16WK10312	E-689A
M16WK10313	E-2412A
M16WK10317	E-1425A
M16WK10317	E-557
M16WK10319	E-685
M16WK10323	E-4885
M16WK10325	E-1095
M16WK10326	E-4716
M16WK10329	E-7218
M16WK1035	E-9710
M16WK1037	E-4712
M16WK10383	E-2796
M16WK10388	E-4718
M16WK1039	E-687
M16WK10410	E-9725
M16WK10417	E-3854
M16WK10423	E-6884
M16WK10425	E-3856
M16WK10510	E-9726
M16WK10517	E-3855
M16WK10523	E-6885
M16WK10525	E-3857
M16WK11012	E-2796
M16WK1104	E-2412
M16WK1104	E-2412A
M16WK11112	E-2797
M16WK1114	E-2413
M16WK1114	E-2413A
M16WK116	E-2794
M16WK117	E-2795
M16WKL10175	E-5516
M16WKL10196	E-9739
M16WKL10205	E-5518
M16WKL10206	E-9267
M16WKL10231	E-6101
M16WKL10236	E-5520
M16WKL10242	E-9727
M16WKL10245	E-6103
M16WKL10264	E-9741
M16WKL20173	E-9096
M16WKL20175	E-5522
M16WKL20205	E-5524
M16WKL20205	E-9739
M16WKL20231	E-5518
M16WKL20231	E-9098
M16WKL20236	E-5526
M16WKL20236	E-6101

COMPETITOR INTERCHANGE

DANA/SPICER (cont)	
COMPETITOR NUMBER	EUCLID NUMBER
M16WKL20242	E-9100
M16WKL20271	E-9729
M16WKL25175	E-9731
M16WKL25205	E-9733
M16WKL25227	E-11856
M16WKL25231	E-11858
M16WKL25236	E-9735
M16WKL25242	E-10909
M16WKL25264	E-11860
M16WKL25271	E-9737
M16WKL25304	E-11862
M16WKR10175	E-5517
M16WKR10196	E-9740
M16WKR10205	E-5519
M16WKR10231	E-6102
M16WKR10236	E-5521
M16WKR10242	E-9728
M16WKR10245	E-6104
M16WKR10264	E-9742
M16WKR20173	E-9097
M16WKR20175	E-5523
M16WKR20205	E-5525
M16WKR20205	E-9740
M16WKR20231	E-5519
M16WKR20231	E-9099
M16WKR20236	E-5527
M16WKR20236	E-6102
M16WKR20242	E-9101
M16WKR20271	E-9730
M16WKR25175	E-9732
M16WKR25205	E-9734
M16WKR25227	E-11857
M16WKR25231	E-11859
M16WKR25236	E-9736
M16WKR25242	E-10910
M16WKR25264	E-11861
M16WKR25271	E-9738
M16WKR25304	E-11863
M16WR100	E-612HD
M16WR105	E-612HD
M16WS100X	E-5500
M16WS103X	E-2778
M16WS132X	E-2241
M16WS135X	E-957
M16WS147X	E-2684
M16WS148X	E-2685
M18WS100X	E-5500
MK101	E-2287
TA144A	E-1816SHD
TA14A	E-1816SHD
TA18A	E-2121
TA192A	E-1607HD

DANA/SPICER (cont)	
COMPETITOR NUMBER	EUCLID NUMBER
TA241A	E-1887ASHD
TA251A	E-2820
TA291A	E-2769SHD
TA291A	E-4515QHD-N
TA341A	E-3710SHD
TA341A	E-4515XHD
TA40A	E-2126
TA41A	E-2286
TA42A	E-2030HD
TA511A	E-4691
TA51A	E-6879
TA521A	E-4692
TA54A	E-5139
TA55A	E-1308Q
TA55A	E-3869
TA63A	E-5481A
TA65A	E-8923
TA66A	E-9064
TA67A	E-8925
TA68A	E-3518
TA82A	E-5086
DAYTON/BATCO	
COMPETITOR NUMBER	EUCLID NUMBER
01004	E-9062
01005	E-11453
01006	E-11454
01007	E-11455
01009	E-11456
01012	E-5480
01015	E-9040
01018	E-9036
01069	E-2728
01070	E-2729
01071	E-2729
01072	E-4785
01074	E-3441
01077	E-5528
01078	E-7230
01079	E-7236
01080	E-5126
010801	E-9027
01085	E-1398
01087	E-3491
01098	E-5239
01100	E-2241
01103	E-2684
01104	E-2686
01105	E-2687
01106	E-2684
01107	E-2241
01108	E-5239

DAYTON/BATCO (cont)	
COMPETITOR NUMBER	EUCLID NUMBER
01111	E-6075
01112	E-2685
01117	E-2685
01120	E-1580
01121	E-3920
01122	E-3713
01123	E-3714
01124	E-3920
01125	E-5092
01127	E-3823
01128	E-2778
01130	E-3303
01131	E-3304
01132	E-3522
01133	E-3417
01138	E-4902
01142	E-5500
01145	E-10804
01146	E-10803
01147	E-10805
01148	E-10809
01149	E-10810
01165	E-10876
01166	E-10877
01167	E-10878
01168	E-2393A
01169	E-2394A
01170	E-5303A
01175	E-2393
01175	E-2393A
01176	E-2394
01178	E-5303A
01182	E-2819
01186	E-2474
01188	E-1777
01191	E-1778
01192	E-2801
01193	E-9054
01194	E-3438
01195	E-3439
01196	E-3441
01198	E-2712
01200	E-523
01200	E-943
01201	E-781
01202	E-586
01204	E-5089
01205	E-500
01-2056	E-9043
01205K	E-2176
01206	E-505
01206K	E-2214

COMPETITOR INTERCHANGE

DAYTON/BATCO (cont)

DAYTON/BATCO (cont)

DAYTON/BATCO (cont)

COMPETITOR NUMBER	EUCLID NUMBER
01207	E-504
01215	E-2802
01217	E-595
01217K	E-2217A
01218	E-795
01219	E-3421A
01222	E-1304
01223	E-2395
01223K	E-2395
01225	E-1406
01227	E-1582
01229	E-2672
01233	E-3231
01233K	E-2395
01234	E-2177
01236	E-3511
01237	E-3421A
01238	E-3483
01239	E-3421A
01240	E-947
01243	E-714
01244	E-3421A
01246	E-523
01247	E-5477
01250	E-501
01-2506	E-9044
01262	E-596A
01263	E-2396
01264	E-2803
01265	E-1305
01271	E-3482
01294	E-5478
01300	E-539
01301	E-527
01302	E-773
01303	E-9045
01305	E-5305
01310	E-1581
01311	E-3227
01313	E-3007A
01314	E-3513
01317	E-9656
01318	E-2399
01319	E-2109
01320	E-747
01321	E-545A
01322	E-1880B
01323	E-543
01324	E-544
01326	E-1025
01329	E-3859
01330	E-2398

COMPETITOR NUMBER	EUCLID NUMBER
01331	E-2398
01335	E-752
01339	E-757
01341	E-1402
01343	E-980
01345	E-1400
01346	E-2768
01348	E-1418
013481	E-10198
01349	E-1428A
01350	E-1583
01352	E-1880B
01354	E-545A
01355	E-544
01356	E-2785
01357	E-5122
01358	E-5123
01359	E-2768
01359	E-3228
01360	E-2804
01361	E-2805
01362	E-2475
01363	E-3872
01364	E-2101
01369	E-2768
01-3696	E-9063
01370	E-2767
01371	E-3512
01372	E-9069
01373	E-3437
01374	E-3437
01375	E-9643
01-3751	E-9643
01376	E-979
01377	E-2770
01378	E-3481A
01379	E-3490B
01380	E-3873
01381	E-5088
01382	E-7232
01383	E-7232
01384	E-7238
01385	E-7238
01386	E-10197
01-3862	E-8907
013863	E-9046
013864	E-10197
01390	E-4800
01391	E-2522
01392	E-2724
01392	E-2725
01392	E-2726

COMPETITOR NUMBER	EUCLID NUMBER
01393	E-5124
01394	E-5125
01400	E-609
01401	E-1112A
01402	E-512
01404	E-2119
01404	E-502
01405	E-503
01406	E-2119
01408	E-1813
01417	E-2390
01420	E-1337
01421	E-608
01424	E-2119
01424	E-502
01-4244	E-9041
01430	E-3445
01431	E-2029
01432	E-1403
01434	E-2766S
01435	E-2773
01437	E-3424
01440	E-512
01441	E-512
01442	E-609
01443	E-1112A
01446	E-2798
01447	E-5304
01448	E-3711
01451	E-3870
01452	E-5087
01453	E-9061
01460	E-537
01462	E-1269
01463	E-1269
01465	E-1416
01470	E-563
01471	E-671
01472	E-1113
01473	E-2391
01475	E-3427
01477	E-3874
01478	E-3871
01480	E-538
01482	E-801
01488	E-2401
01489	E-2392
01490	E-579A
01-4903	E-9042
01492	E-5093
01493	E-1106
01497	E-1107

COMPETITOR INTERCHANGE

DAYTON/BATCO (cont)		DAYTON/BATCO (cont)		DAYTON/BATCO (cont)	
COMPETITOR NUMBER	EUCLID NUMBER	COMPETITOR NUMBER	EUCLID NUMBER	COMPETITOR NUMBER	EUCLID NUMBER
01497	E-3975	02220	E-1567	03140	E-5476
01499	E-2723	02224	E-2690A	03141	E-5476
01500	E-541	02225	E-5127	031451	E-11897
01-5002	E-9047	02227	E-961	03146	E-4737A
01503	E-1808	02228	E-2732	03147	E-4738A
01509	E-2218	02229	E-2716	03148	E-9590
01510	E-530	02230	E-2380	03149	E-9591
01600	E-633X	02231	E-1271	03150	E-9592
01601	E-634X	02232	E-2551	03151	E-9593
01602	E-583X	02233	E-3447	03152	E-9594
01603	E-635X	02235	E-2389	03153	E-4737A
01604	E-636X	02240	E-2670	03154	E-9596
01605	E-628X	02241	E-2407	03155	E-9597
01606	E-797X	02242	E-2408	03160	E-4934A
01607	E-798X	02244	E-3877	03161	E-5241A
01608	E-998X	02246	E-6080	03162	E-5240A
01609	E-999X	02248	E-6076	03168	E-4739
01612	E-911X	02249	E-9783	03169	E-10947
01613	E-912X	02256	E-9789	03170	E-8906
01614	E-914X	02257	E-11449	03180	E-5243A
01615	E-913X	02300	E-654	03181	E-5244A
01616	E-917X	02304	E-1416A	03182	E-5242A
01617	E-918X	02306	E-1272	03183	E-9601
01650	8-8S	02309	E-2406	03184	E-9602
01651	8-9S	02310	E-2405	03200	E-535
01652	8-10S	02312	E-1416	03201	E-661
01658	10-8S	02313	E-2405	03202	E-1385
01659	10-9S	02314	E-1314	03203	E-602
01660	10-10S	02315	E-5128	03205	E-1318A
01664	20-8S	02316	E-3469	03206	E-1571
01665	20-9S	02317	E-2717	03207	E-1577A
01666	20-10B	02318	E-3878	03207	E-4594
02125	E-1108	02319	E-3878	03208	E-2102
02132	E-957	02326	E-3859	03209	E-1318A
02136	E-957	02350	E-564	03210	E-2517
02200	E-943	02350	E-580	03212	E-2361
02201	E-943	02353	E-1416A	03213	E-1314
02202	E-536	02400	E-864	03214	E-2695
02203	E-759	02507	E-3775	03250	E-603
02204	E-807	02507	E-886	03254	E-2477B
02205	E-712	02508	E-3775	03258	E-1319A
02206	E-667	02508	E-886	03259	E-1319A
02207	E-662	02515	E-9095A	03259	E-2477B
02210	E-536	03114	E-2104	03260	E-1319A
02210	E-5512	031141	E-9788A	03260	E-2477B
02211	E-667	031142	E-9787A	03261	E-1319A
02213	E-661	03115	E-2103	03264	E-4594
02214	E-712	03125	E-2104	03266	E-4593
02216	E-920	03126	E-2103	03268	E-4586
02217	E-919	03131	E-1318A	03270	E-4594
02218	E-2291	03131	E-1319A	03271	E-4593
02219	E-1893	03136	E-9593	03272	E-4587

COMPETITOR INTERCHANGE

DAYTON/BATCO (cont)

COMPETITOR NUMBER	EUCLID NUMBER
03273	E-4586
04002	E-9726
04003	E-9725
04004	E-3855
04005	E-3854
04006	E-6885
04007	E-6884
04008	E-3857
04009	E-3856
04010	E-5059
04011	E-5058
04012	E-5130
04013	E-5129
04014	E-5061
04015	E-5060
04016	E-5067
04017	E-5066
04018	E-5132
04019	E-5131
04020	E-5134
04021	E-5133
04022	E-5136
04023	E-5135
04024	E-5063
04025	E-5062
04050	E-9660
04051	E-9659
04066	E-4901
04067	E-4900
04068	E-9088
04069	E-9087
04084	E-9712
04085	E-9711
04086	E-5529
04086	E-5530
04087	E-5529
04088	E-9708
04089	E-9707
04090	E-3517
04091	E-3516
04096	E-5494
040961	E-9058
04097	E-5495
040971	E-9057
04098	E-5496
040981	E-9060
04099	E-5497
040991	E-9059
04100	E-4716
04101	E-4717
04102	E-2797
04103	E-2796

DAYTON/BATCO (cont)

COMPETITOR NUMBER	EUCLID NUMBER
04104	E-1095
04105	E-1094
04106	E-4885
04107	E-4884
04108	E-9090
04109	E-9089
04110	E-684
04111	E-685
04116	E-2413
04117	E-2412
04118	E-688
04119	E-689
04120	E-686
04121	E-687
04122	E-4715
04123	E-4714
04124	E-9709
04125	E-9710
04132	E-2794
04133	E-2795
04134	E-7218
04135	E-7217
04136	E-4712
04137	E-4713
04142	E-9692A
04143	E-9691A
04144	E-4708B
04145	E-4709B
04-150761	E-5059
04150762	E-5058
04150811	E-5130
04150811	E-5138
04150812	E-5129
04150861	E-5061
04150862	E-5060
04150911	E-5067
04150912	E-5066
04150931	E-5132
04150932	E-5131
04150961	E-5134
04150962	E-5133
04151001	E-5136
04151002	E-5135
04151111	E-5063
04151112	E-5062
04156	E-1788
04157	E-1789
04160811	E-9029
04160812	E-9028
04160931	E-9031
04160932	E-9030
04160961	E-9033

DAYTON/BATCO (cont)

COMPETITOR NUMBER	EUCLID NUMBER
04160962	E-9032
04161001	E-9035
04161002	E-9034
04161111	E-9035
04161112	E-9034
04166	E-9690A
04167	E-9689A
04168	E-2714A
04169	E-2715A
04170	E-5056
04171	E-5057
04174	E-9688
04175	E-9687A
04180	E-1089
04181	E-1090
04190	E-4996
04190811	E-3461
04190812	E-3460
04190851	E-4917
04190852	E-4916
04190931	E-4919
04190932	E-4918
04191	E-4995
04192	E-3461
04193	E-3460
04194	E-4917
04195	E-4916
04196	E-4919
04197	E-4918
04198	E-2108
04199	E-2107
04200771	E-4913
04200771	E-9694
04200772	E-4912
04200772	E-9693
04200811	E-9696
04200812	E-9695
04200851	E-9698
04200852	E-9697
04200931	E-9700
04200932	E-9699
04200961	E-9702
04200962	E-9701
04201001	E-9704
04202	E-2694
04203	E-2693
04204	E-4720
04205	E-4721
04206	E-4722
04207	E-4723
04210851	E-9708
04210852	E-9707

COMPETITOR INTERCHANGE

DAYTON/BATCO (cont)		DAYTON/BATCO (cont)		DAYTON/BATCO (cont)	
COMPETITOR NUMBER	EUCLID NUMBER	COMPETITOR NUMBER	EUCLID NUMBER	COMPETITOR NUMBER	EUCLID NUMBER
04210931	E-5529	04269	E-2787	04340	E-3471
04210931	E-5530	04270	E-4887	04341	E-3472
04210932	E-5529	04271	E-4886	04344	E-3477
04210961	E-9712	04271051	E-2700B	04345	E-3475
04210962	E-9711	04271052	E-2701B	04346	E-3474
04214	E-5097	04271151	E-1147C	04347	E-2733
04215	E-5096	04271152	E-1148C	04347	E-3476
04216	E-1410	04272	E-4889	04348	E-2733
04217	E-1411	04273	E-4888	04350	E-5137
04218	E-1420	04274	E-3524	04351	E-5138
04219	E-1421	04275	E-3523	04356	E-9076
04220	E-1423	04276	E-9766	04357	E-5482
04221	E-1422	04277	E-9765	04358	E-2411A
04222	E-1393	04278	E-1564	04359	E-9073
04223	E-1394	04279	E-1563	04361	E-9074
04224	E-9748	04280	E-2100	04362	E-9075
04225	E-9747	04280771	E-9646	04363	E-9077
04226	E-9746	04280772	E-9645	04370861	E-2799
04227	E-9745	04281	E-2099	04370862	E-2800
04230771	E-9714	04281211	E-9666	04371021	E-9764
04230772	E-9713	04281212	E-9665	04371022	E-9763
04230941	E-9716	04282	E-9762	04371051	E-4887
04230942	E-9715	04283	E-9761	04371052	E-4886
04231011	E-9718	04284	E-3862	04371121	E-9766
04231012	E-9717	04285	E-3861	04371122	E-9765
04236	E-9744	04286	E-4891	04371151	E-1775
04237	E-9743	04287	E-4890	04371152	E-1776
04240	E-2492	04300	E-656	04371251	E-2786
04240761	E-1089	04301	E-10845	04371252	E-2787
04240762	E-1090	04301	E-581	04371311	E-4889
04240901	E-4996	04302	E-580	04371312	E-4888
04240902	E-4995	04303	E-719	04371351	E-4741
04241	E-2493	04304	E-1565	04371352	E-4740
04250	E-2792	04306	E-1408	04371431	E-3524
04251	E-2793	04307	E-1782	04371432	E-3523
04254	E-4741	04308	E-1781	04371511	E-9056
04255	E-4740	04309	E-1113	04371512	E-9055
04258	E-9764	04310	E-526	04390861	E-5491
04259	E-9763	04314	E-910	04390862	E-5490
04260871	E-11522	04315	E-1569	04391051	E-9768
04260872	E-11523	04317	E-910	04391052	E-9767
04260931	E-9065	04318	E-4736	04391161	E-5493
04260932	E-9066	04319	E-3234	04391162	E-5492
04260951	E-9067A	04320	E-2411A	04391251	E-9770
04260951	E-9068A	04321	E-6077	04391252	E-9769
04260952	E-9067A	04322	E-3479	04391311	E-10912
04260952	E-9068A	04327	E-2404	04391312	E-10911
04264	E-1776	04328	E-2409	04391351	E-10912
04265	E-1775	04332	E-3473	04391351	E-10916
04266	E-2799	04334	E-3478	04391352	E-10911
04267	E-2800	04338	E-9071	04391352	E-10915
04268	E-2786	04339	E-3473	04391441	E-9772

COMPETITOR INTERCHANGE

DAYTON/BATCO (cont)

DAYTON/BATCO (cont)

DAYTON/BATCO (cont)

COMPETITOR NUMBER	EUCLID NUMBER
04391442	E-9771
04391521	E-10914
04391522	E-10913
04410531	E-10864
04410532	E-10863
04410621	E-10860
04410622	E-10859
04410771	E-10861
04410772	E-10862
04450	E-5507
04450651	E-4707B
04450652	E-4705B
04450811	E-4706B
04450812	E-4707B
04450821	E-5056
04450822	E-5057
04450861	E-2478B
04450862	E-2479B
04450921	E-9688
04450921	E-9688A
04450922	E-9687A
04450922	E-9687A
04451	E-5506
04451031	E-1788
04451032	E-1789
04451051	E-2700B
04451052	E-2701B
04451121	E-1773C
04451122	E-1774C
04451151	E-1147C
04451152	E-1148C
04451171	E-4702B
04451172	E-4703B
04451221	E-2714A
04451222	E-2715A
04451251	E-4708B
04451252	E-4709B
04451371	E-9690A
04451371	E-9690A
04451372	E-9689A
04451372	E-9689A
04451501	E-9692A
04451501	E-9692A
04451502	E-9691A
04451502	E-9691A
04451561	E-4710B
04451562	E-4711B
04452	E-5509
04453	E-5508
04454	E-5511
04455	E-5510
04460821	E-9648

COMPETITOR NUMBER	EUCLID NUMBER
04460822	E-9647
04460851	E-9650
04460852	E-9649
04460921	E-9652
04460922	E-9651
04460951	E-9654
04460952	E-9653
04461031	E-11536
04461032	E-11537
04461051	E-9656
04461052	E-9655
04461101	E-9658
04461102	E-9657
04461121	E-9660
04461121	E-9660
04461122	E-9659
04461122	E-9659
044611311	E-9670
04461151	E-9662
04461152	E-9661
04461161	E-9664
04461162	E-9663
04461251	E-9668
04461252	E-9667
04461311	E-9670
04461312	E-9669
04461331	E-9672
04461332	E-9671
04461341	E-4732A
04461342	E-4733A
04461351	E-4732A
04461351	E-9674A
04461352	E-4733A
04461352	E-9673A
04461361	E-4911A
04461362	E-4910A
04461421	E-9676
04461422	E-9675
04461461	E-9678
04461462	E-9677
04461531	E-9682
04461532	E-9681
04461571	E-9684
04461572	E-9683
04461651	E-11592
04461652	E-11593
04461722	E-9675
04472041	E-2107
04480	E-9702
04480771	E-9646
04480772	E-9645
04480821	E-9648

COMPETITOR NUMBER	EUCLID NUMBER
04480822	E-9647
04480831	E-11516
04480832	E-11517
04480861	E-9650
04480862	E-9649
04480921	E-9652
04480922	E-9651
04480951	E-9654
04480952	E-9653
04481	E-9701
04481031	E-5505A
04481032	E-5504A
04481041	E-9656
04481042	E-9655
04481051	E-11540
04481052	E-11541
04481111	E-9658
04481112	E-9657
04481121	E-9660
04481122	E-9659
04481151	E-9662
04481152	E-9661
04481171	E-9664
04481172	E-9663
04481211	E-9666
04481212	E-9665
04481251	E-9668
04481252	E-9667
04481311	E-9670
04481312	E-9669
04481331	E-9672
04481332	E-9671
04481341	E-4732A
04481341	E-9674A
04481342	E-4733A
04481342	E-9673A
04481351	E-9674A
04481352	E-9673A
04481421	E-9676
04481422	E-9675
04481461	E-9678
04481462	E-9677
04481471	E-9680
04481472	E-9679
04481531	E-9682
04481532	E-9681
04481561	E-10307A
04481562	E-10306A
04481571	E-9684
04481572	E-9683
04481601	E-11584
04481602	E-11585

COMPETITOR INTERCHANGE

DAYTON/BATCO (cont)	
COMPETITOR NUMBER	EUCLID NUMBER
04481811	E-11600
04481812	E-11601
04492	E-5093
04524	E-5491
04525	E-5490
04530	E-5493
04531	E-5492
04534	E-9772
04535	E-9771
04542051	E-10902
04542052	E-10901
04542131	E-10904
04542132	E-10903
04542321	E-10906
04542322	E-10905
04542401	E-10908
04542402	E-10907
04560	E-5517
04561	E-5516
04561741	E-9732
04561742	E-9731
04562	E-5519
04562041	E-9734
04562042	E-9733
04562301	E-11859
04562302	E-11858
04562351	E-9735
04562352	E-9736
04562411	E-10910
04562412	E-10909
04562631	E-11861
04562632	E-11860
04562701	E-9738
04562702	E-9737
04563	E-5518
04566	E-6102
04567	E-6101
04568	E-5521
04569	E-5520
04570	E-9728
04571	E-9727
04571561	E-9710
04571562	E-9709
04571631	E-4712
04571632	E-4713
04571651	E-686
04571652	E-687
04571741	E-2794
04571742	E-2795
04571761	E-4714
04571761	E-4714A
04571762	E-4715

DAYTON/BATCO (cont)	
COMPETITOR NUMBER	EUCLID NUMBER
04571762	E-4715A
04571841	E-688
04571841	E-688A
04571842	E-689
04571842	E-689A
04571861	E-2412
04571861	E-2412A
04571862	E-2413
04571862	E-2413A
04572041	E-1424A
04572042	E-1425A
04572111	E-684
04572112	E-685
04572241	E-9090
04572242	E-9089
04572301	E-4885
04572302	E-4884
04572351	E-1094
04572352	E-1095
04572411	E-4716
04572412	E-4717
04572441	E-2796
04572442	E-2797
04572571	E-4718
04572572	E-4719
04572631	E-7218
04572632	E-7217
04572651	E-7218
04572652	E-7217
04574741	E-2794
04578	E-9730
04579	E-9729
04580	E-5523
04581	E-5522
04581741	E-9726
04581742	E-9725
04582	E-5525
04582041	E-3855
04582042	E-3854
04582271	E-6885
04582272	E-6884
0458235	E-3856
04582351	E-3857
04582352	E-3856
04582411	E-5517
04582412	E-5516
04583	E-5524
04586	E-9099
04587	E-9098
04588	E-5527
04589	E-5526
04591741	E-5517

DAYTON/BATCO (cont)	
COMPETITOR NUMBER	EUCLID NUMBER
04591742	E-5516
04591951	E-9740
04591952	E-9739
04592041	E-5519
04592042	E-5518
04592301	E-6102
04592302	E-6101
04592351	E-5521
04592352	E-5520
04592411	E-9728
04592412	E-9727
04592441	E-6104
04592442	E-6103
04592631	E-9742
04592632	E-9741
04601721	E-9097
04601722	E-9096
04601741	E-5523
04601742	E-5522
04602041	E-5525
04602042	E-5524
04602301	E-9099
04602302	E-9098
04602351	E-5527
04602352	E-5526
04602411	E-9101
04602412	E-9100
04602701	E-9730
04602702	E-9729
04604	E-9752
04605	E-9751
04606	E-9264
04607	E-9263
04608	E-9750
04609	E-9749
04610	E-9266
04611	E-9265
04611901	E-9744
04611902	E-9743
04612	E-9268
04612051	E-5097
04612052	E-5096
04612121	E-1410
04612122	E-1411
04612211	E-9746
04612212	E-9745
04612321	E-1422
04612322	E-1423
04612401	E-1420
04612402	E-1421
04612461	E-2792
04612462	E-2793

COMPETITOR INTERCHANGE

DAYTON/BATCO (cont)

COMPETITOR NUMBER	EUCLID NUMBER
04612651	E-9748
04612652	E-9747
04613	E-9267
04614	E-9270
04615	E-9269
04616	E-9272
04617	E-9271
04618	E-9274
04619	E-9273
04620	E-9278
04621	E-9277
04622	E-9280
04623	E-9279
04631621	E-9264
04631622	E-9263
04631741	E-9752
04631742	E-9751
04631811	E-9750
04631812	E-9749
04631901	E-9266
04631902	E-9265
04632051	E-9268
04632052	E-9267
04632131	E-9270
04632132	E-9269
04632211	E-9272
04632212	E-9271
04632321	E-9274
04632322	E-9273
04632351	E-9276
04632352	E-9275
04632401	E-9278
04632402	E-9277
04632631	E-9280
04632632	E-9279
04642041	E-9754
04642042	E-9753
04642131	E-9756
04642132	E-9755
04642211	E-9758
04642212	E-9757
04642321	E-9760
04642322	E-9759
04652	E-9029
04653	E-9028
04662	E-9031
04663	E-9030
04664	E-9033
04665	E-9032
04666	E-9035
04667	E-9034
04671641	E-10918

DAYTON/BATCO (cont)

COMPETITOR NUMBER	EUCLID NUMBER
04671642	E-10917
04672031	E-10920
04672032	E-10919
04672121	E-10922
04672122	E-10921
04672231	E-10924
04672232	E-10923
04672341	E-10926
04672342	E-10925
04672471	E-10928
04672472	E-10927
04672651	E-10930
04672652	E-10929
04694	E-9716
04695	E-9715
04710	E-9754
04711	E-9753
04711951	E-2694
04711952	E-2693
04712	E-9756
04712371	E-4720
04712372	E-4721
04713	E-9755
04714	E-9758
04715	E-9757
04716	E-9760
04717	E-9759
04719	E-9760
04722021	E-4722
04722022	E-4723
04730	E-9065
04731	E-9066
04731941	E-5495
04731942	E-5494
04732361	E-5496
04732362	E-5497
04741941	E-9058
04741942	E-9057
04742361	E-9060
04742362	E-9059
04772041	E-2108
04772042	E-2107
04782031	E-1393
04782032	E-1394
04782231	E-2492
04782232	E-2493
04811621	E-1564
04811622	E-1563
04812121	E-2100
04812122	E-2099
04812401	E-3862
04812402	E-3861

DAYTON/BATCO (cont)

COMPETITOR NUMBER	EUCLID NUMBER
04821621	E-9762
04821622	E-9761
04832121	E-4891
04832122	E-4890
04848092	E-9651
04851121	E-11865
04851122	E-11864
04871121	E-11867
04871122	E-11866
04881731	E-2448A
04881732	E-2447A
04882041	E-2450A
04882042	E-2449A
04882421	E-2452A
04882422	E-2451A
04891731	E-2442B
04891732	E-2441B
04892041	E-2444B
04892042	E-2443B
04892421	E-2446B
04892422	E-2445B
04911731	E-5507
04911732	E-5506
04912041	E-5509
04912042	E-5508
04912421	E-5511
04912422	E-5510
04931421	E-5511
04931422	E-5510
04931731	E-5507
04931732	E-5506
04932041	E-5509
04932042	E-5508
04932421	E-5511
04932422	E-5510
04942041	E-4901
04942042	E-4900
04942331	E-9088
04942332	E-9087
04952041	E-3517
04952042	E-3516
04952331	E-9088
04952332	E-9087
05201	E-940HD
05203	E-612HD
05210	E-2307
05211	E-940HD
05214	E-4904S
05218	E-612HD
05219	E-612HD
05224	E-2668
05225	E-2669

COMPETITOR INTERCHANGE

DAYTON/BATCO (cont)		DAYTON/BATCO (cont)		DAYTON/BATCO (cont)	
COMPETITOR NUMBER	EUCLID NUMBER	COMPETITOR NUMBER	EUCLID NUMBER	COMPETITOR NUMBER	EUCLID NUMBER
05227	E-2763	07178	E-5532	07930	E-2015
05228	E-2760	07179	E-5532	07931	E-2015
05233	E-2763	07187	E-3499	081001	E-1816S
05234	E-2760	07194	E-5537	08100100	E-1816HD
05237	E-2459HD	07195	E-5538	08100100	E-4515PHD
05238	E-2458HD	07200	E-5537	08100160	E-1816SHD
05240	E-1574HD	07201	E-5538	08100160	E-4515PHD
05241	E-9106	07210	E-2135	081003	E-1816HD
05244	E-2668	07211	E-2134	081003	E-1816S
05245	E-2669	07212	E-1137	08100300	E-1816S
05250	E-2091	07213	E-1136	08100300	E-4515P
05251	E-5498	07214	E-2137	08100305	E-1816HD
05254	E-9102	07215	E-2136	08100305	E-4515PHD
05256	E-9103	07216	E-2139	08100360	E-1816SHD
05257	E-9104	07-217	E-2138	08100360	E-4515PHD
05260	E-612HD	07230	E-3996	081004	E-1816SHD
05261	E-6113	07231	E-3997	081006	E-2121
05261	E-940HD	07232	E-3998	08100600	E-2121
05262	E-2458HD	07233	E-3999	08100660	E-2121HD
05263	E-2459HD	07246	E-5541	081035	E-1816SHD
05264	E-1574HD	07256	E-5540	081035	E-4515PHD
05294	E-9105	07260	E-2193	081036	E-1816HD
05552	E-10949A	07270	E-5540	081038	E-1816S
05560	E-6991A	07272	E-5540	081042	E-1887ASHD
05561	E-6992A	07506	E-1489	081042	E-4311EHD-N
05562	E-6993A	07523	E-1493	08104200	E-1887ASHD
05563	E-6994A	07523	E-1495	08104200	E-4311EHD-N
05564	E-6995A	07523	E-1496	08104230	E-2820
05565	E-6996A	07524	E-2552	08104300	E-9141
05570	E-6987A	07534	E-2164	08104330	E-9039
05570	E-6988A	07535	E-2163	081047	E-1816S
05572	E-6989A	07536	E-1497	081047	E-4515P
05572	E-6990A	07537	E-2745	08104700	E-10875
07103	E-1457	07551	E-2154	08104900	E-10756
07105	E-2689	07552	E-2155	08105000	E-10757
07107	E-1139	07553	E-2156	081051	E-5306
07115	E-3495	07554	E-2153	08105100	E-5306
07121	E-2522	07570	E-2281	08105105	E-3782
07123	E-3525	07571	E-2282	081053	E-2820
07134	E-1140	07574	E-1214	081072	E-1812
07136	E-1458	07585	E-1216	081073	E-2030HD
07137	E-2476	07586	E-1217	08107300	E-2030HD
07150	E-2140	07587	E-1215	081074	E-2402HD
07151	E-1261	07590	E-1218	08107400	E-2402HD
07152	E-2141	07595	E-1230	08107401	E-3373HD
07153	E-2142	07600	E-2161	081075	E-2403HD
07163	E-2484	07601	E-2162	08107500	E-1357A
07168	E-3492	07605	E-1486	08107500	E-2403HD
07169	E-2484	07900	E-1128	08107501	E-3374HD
07173	E-3994	07906	E-1262	081076	E-2126
07174	E-3995	07907	E-1735	08107600	E-2126
07177	E-5532	07909	E-2290	081077	E-2286

COMPETITOR INTERCHANGE

DAYTON/BATCO (cont)

COMPETITOR NUMBER	EUCLID NUMBER
08107700	E-2286
081081	E-2676
08108110	E-2676
081082	E-1607HD
08108200	E-1607HD
08108260	E-1607HD
081083	E-2675HD
08108300	E-2675HD
081084	E-2713
08108400	E-2713
081088	E-2769HD
081088	E-2769S
08108800	E-2769SHD
08108800	E-4515QHD-N
08108801	E-2769S
08108801	E-4515Q-N
08108805	E-2769S
08108805	E-4515Q-N
08108810	E-6999S
08108812	E-3895S
08108812	E-4515U
08108815	E-6999S
08108817	E-3895S
08108817	E-4515U
08108830	E-2769HD
08108830	E-4515QHD-N
08108831	E-2769HD
08108831	E-4515QHD-N
08108838	E-2769HD
08108838	E-2769SHD
08108845	E-6999SHD
08108847	E-3895SHD
08108847	E-4515UHD
08108850	E-9644
08108865	E-2769HD
08108865	E-2769SHD
08108865	E-4515QHD-N
08108875	E-2769HD
08108875	E-4515QHD-N
081090	E-4880S
08109000	E-4880S
08109030	E-4880SHD
081091	E-3710S
08109100	E-3710S
08109100	E-4515X
08109105	E-3710S
08109105	E-4515X
08109130	E-3710HD
08109130	E-4515XHD
08109134	E-3710HD
08109134	E-4515XHD
08109135	E-3710SHD

DAYTON/BATCO (cont)

COMPETITOR NUMBER	EUCLID NUMBER
08109135	E-4515XHD
08109138	E-3710HD
08109138	E-3710SHD
08109165	E-3710HD
08109165	E-3710SHD
08109165	E-4515XHD
081092	E-2769HD
081093	E-3484
08109300	E-3484
081095	E-5499
08109500	E-5499
08109560	E-5499
081096	E-2821
08109600	E-2821
081098	E-3992
08109800	E-3992
08109830	E-3518
081099	E-3291
08109900	E-3291
081102	E-2740
08110200	E-2740
081103	E-1816HD
081103	E-3801
081105	E-3518
081107	E-4691
08110700	E-1308T
08110700	E-4691
081108	E-4692
08110800	E-4692
081109	E-4692
08110900	E-4692
081111	E-3869
08111100	E-1308Q
08111100	E-3869
08111102	E-1308Q
08111102	E-7899
081112	E-7899
08111200	E-1308Q
08111200	E-7899
081113	E-5139
08111300	E-1308E
08111300	E-5139
081115	E-5086
08111500	E-5086
08111600	E-9644
08111630	E-9644
081121	E-1816HD
081122	E-1887AHD
081122	E-4311EHD-N
081124	E-2121HD
081126	E-2769HD
081126	E-4515QHD-N

DAYTON/BATCO (cont)

COMPETITOR NUMBER	EUCLID NUMBER
081127	E-4880SHD
081128	E-3373HD
081129	E-3374HD
081130	E-3710HD
081132	E-2769HD
081132	E-2769SHD
081134	E-2121HD
081135	E-4880SHD
081136	E-3710HD
081136	E-3710SHD
081136	E-4515XHD
081137	E-9142
08113700	E-9142
081140	E-7231
08114000	E-7231
08114002	E-7237
081142	E-7237
08114200	E-7237
081146	E-3782
08114700	E-11981
081148	E-5481A
08114800	E-4709ES-N
08114800	E-5481A
08114900	E-10756
08114920	E-10760
081154	E-8925
08115400	E-8925
081156	E-9052
08115600	E-9052
081157	E-9048
08115700	E-9048
081158	E-8923
08115800	E-8923
081160	E-9064
08116000	E-4702-KT
08116000	E-9064
081162	E-5515
08116200	E-5515
08125102	E-10866A
08125300	E-10870
081300	E-1357A
081301	E-2088A
081301	E-2088AHD
08130100	E-2363
08130101	E-2088A
08130101	E-2088AHD
08130101	E-2363
08130110	E-2679A
08130111	E-2679A
08130122	E-1357A
08130132	E-2089
081302	E-2086B

COMPETITOR INTERCHANGE

DAYTON/BATCO (cont)		DAYTON/BATCO (cont)		DAYTON/BATCO (cont)	
COMPETITOR NUMBER	EUCLID NUMBER	COMPETITOR NUMBER	EUCLID NUMBER	COMPETITOR NUMBER	EUCLID NUMBER
08130200	E-2086B	081353	E-9053	081910	E-7213A
08130250	E-2086B-2	081361	E-3876	081919	E-5543
08130300	E-9791HD	08136100	E-3876	08191902	E-5543
08130301	E-9791HD	081364	E-2696A	081927	E-5542
08130310	E-11450HD	08136400	E-2696A	081930	E-2158
08130311	E-11450	081366	E-2494	081932	E-2157
08130311	E-11450HD	08136600	E-2494	08193200	E-2157
081305	E-2679A	081368	E-3468A	08193204	E-2746
081305	E-2679AHD	08136800	E-3468A	08193205	E-1934
081306	E-2382	081369	E-3446	08193303	E-2158
08130600	E-2282	08136900	E-3446	08-1934	E-2746
08130600	E-2382	081370	E-3353A	081937	E-2159
08130601	E-3520A	08137000	E-3353A	092253	E-937
08130610	E-6078	081371	E-3354	097240	E-9321
08130611	E-9079HD	08137100	E-3354	1004	E-9062
081307	E-2089	081373	E-9080	1008	E-5503
081308	E-2089	08137300	E-9080	1010SQ	10-10S
081308	E-2123	081375	E-5140	1012	E-5480
08130800	E-2089	08137500	E-5140	1015	E-9040
08130800	E-2123	081376	E-3520A	102635	E-937
081311	E-2363	081378	E-7235	1069	E-2728
081318	E-3993B	08137800	E-7235	1070	E-2729
08131800	E-3993B	08138100	E-3993B	1071	E-2729
08131804	E-5513	08140500	E-10846	1072	E-4785
081321	E-2287	08140600	E-10868	1074	E-3441
08132100	E-2287	08140601	E-10871	1077	E-5528
08132103	E-2087	081422	E-2030HD	1078	E-7230
08132111	E-2680	081425	E-6999S	1079	E-7236
08132150	E-2287-2	081428	E-3895S	1080	E-5126
081323	E-2469	081700	E-6999S	10801	E-9027
08132300	E-2469	081701	E-6999SHD	1085	E-1398
081324	E-2087	081702	E-2769S	1087	E-3491
081325	E-2680	081702	E-4515Q-N	108SQ	10-8S
08132800	E-9790A	081703	E-2769SHD	1096	E-2687
08132803	E-11910	081703	E-4515QHD-N	1098	E-5239
08132803	E-9790A	081704	E-3895SHD	109SQ	10-9S
08132850	E-9790A	081704	E-4515UHD	1100	E-2241
081330	E-2122	081709	E-1887ASHD	110212	E-700
081331	E-2090	081709	E-4311EHD-N	1103	E-2684
08133100	E-2090	081711	E-4880SHD	1104	E-2686
08133101	E-2122	081713	E-3710SHD	1105	E-2687
08133150	E-2090-2	081713	E-4515XHD	110554	E-9568
08133151	E-2122-2	081716	E-1816S	1106	E-2684
081341	E-2469	081716	E-4515P	110619	20415541009
081341	E-2526	081717	E-1816SHD	11-0623	20415502021
08134100	E-2526	081717	E-4515PHD	110624	20415502021
081351	E-2125	081850	E-2086B	1107	E-2241
081351	E-5501	081900	E-7212A	1108	E-5239
0813510	E-5501	08190020	E-7212A	11098	E-702A
08135100	E-2125	081909	E-7214A	1111	E-6075
08135110	E-9053	08190921	E-1909	1112	E-2685
081352	E-5501	08190922	E-7213A	1117	E-2685

COMPETITOR INTERCHANGE

DAYTON/BATCO (cont)

COMPETITOR NUMBER	EUCLID NUMBER
111820	E-2098
111821	E-2098
111830	E-1362
111831	E-1250
111832	E-2739
111880	E-2644
111886	E-2655
111887	E-2654
111888	E-2656
111901	E-1901
111902	E-1902
111903	E-1903
111904	E-1904
111905	E-1905
111906	E-1906
111907	E-1907
111908	E-1908
111909	E-1909
111910	E-1910
111911	E-1911
111912	E-1912
111913	E-1913
111914	E-1914
111915	E-1915
111916	E-1916
111917	E-1917
111918	E-1918
111919	E-1919
111920	E-1920
111921	E-1921
111922	E-1922
111923	E-1923
111924	E-1924
111925	E-1925
111926	E-1926
111927	E-1927
111928	E-1928
111929	E-1929
111930	E-1930
111931	E-1931
111932	E-1932
111933	E-1933
111934	E-1934
111935	E-1935
111936	E-1936
111937	E-1937
111938	E-6137
111939	E-3371
111941	E-1597A
111946	E-1597A
111960	E-5850
111961	E-5851

DAYTON/BATCO (cont)

COMPETITOR NUMBER	EUCLID NUMBER
111963	E-5856
111968	E-5855
111969	E-5854
111981	E-6038
111986	E-5833
111987	E-5834
111993	E-5206
111994	E-5207
111995	E-5208
1120	E-1580
112000	E-5205
1121	E-3920
1122	E-3713
1123	E-3714
1124	E-3920
1125	E-5092
1127	E-3823
1128	E-2778
1130	E-3303
1131	E-3304
1132	E-3522
1133	E-3417
1138	E-4902
1142	E-5500
1145	E-10804
1146	E-10803
1147	E-10805
1148	E-10809
1149	E-10810
1165	E-10876
1166	E-10877
1167	E-10878
1168	E-2393A
1169	E-2394A
1170	E-5303A
1176	E-2394
1178	E-5303A
1182	E-2819
1186	E-2474
1188	E-1777
1191	E-1778
1192	E-2801
1193	E-9054
1194	E-3438
1195	E-3439
1198	E-2712
1200	E-2177
1200	E-523
1200	E-943
1201	E-2215
1201	E-781
1202	E-586

DAYTON/BATCO (cont)

COMPETITOR NUMBER	EUCLID NUMBER
1204	E-5089
1205	E-2111A
1205	E-2176
1205	E-500
1205302	E-662
12056	E-9043
1206	E-505
1207	E-504
1215	E-2802
1217	E-2217A
1217	E-595
1218	E-795
1219	E-3421A
1223	E-2395
1225	E-1406
1227	E-1582
1229	E-2672
1229	E-3914
1233	E-3231
1234	E-2177
1236	E-3511
1237	E-3421A
1238	E-3483
1239	E-3421A
12399	E-5207
1244	E-3421A
1246	E-523
1247	E-5477
1250	E-501
12506	E-9044
1262	E-596A
1263	E-2396
1264	E-2803
1271	E-3482
1294	E-5478
1300	E-539
1301	E-527
1302	E-773
1303	E-9045
1305	E-5305
1310	E-1581
1311	E-3227
1313	E-3007A
1314	E-3513
1318	E-2389
1318	E-2399
1320	E-747
1321	E-545A
1322	E-1880B
1323	E-543
1326	E-1025
1329	E-3859

COMPETITOR INTERCHANGE

DAYTON/BATCO (cont)		DAYTON/BATCO (cont)		DAYTON/BATCO (cont)	
COMPETITOR NUMBER	EUCLID NUMBER	COMPETITOR NUMBER	EUCLID NUMBER	COMPETITOR NUMBER	EUCLID NUMBER
1330	E-2398	13864	E-10197	1493	E-1106
133052	E-6000A	1390	E-4800	1497	E-1107
1331	E-2398	1391	E-2522	1499	E-2723
133116	E-6000A	1392	E-2724	1500	E-2218
1335	E-752	1392	E-2725	1500	E-541
1339	E-2398	1393	E-5124	15002	E-9047
1339	E-757	1394	E-5125	1503	E-1808
1341	E-1402	1400	E-609	1509	E-2218
1343	E-980	1401	E-1112A	1509	E-541
1345	E-1400	1402	E-512	1510	E-530
1346	E-2768	1404	E-2119	16119081	E-3518
1346	E-3490B	1404	E-502	18H01456	E-4078
1348	E-1418	1406	E-2119	2125	E-1108
1349	E-1428A	1417	E-2390	2132	E-957
1350	E-1583	1420	E-1337	2136	E-957
1352	E-1880B	1424	E-2119	2201	E-943
1354	E-545A	1424	E-502	2202	E-536
1355	E-544	14244	E-9041	2203	E-759
1356	E-2785	1430	E-3445	2204	E-807
1357	E-5122	1431	E-2029	2205	E-712
1358	E-5123	1432	E-1403	2206	E-667
1359	E-2768	1434	E-2766S	2207	E-662
1360	E-2804	1435	E-2773	2210	E-536
13-6010	E-6000A	1437	E-3424	2210	E-5512
1361	E-2805	1440	E-512	2211	E-667
1362	E-2475	1440	E-512S	2213	E-661
1363	E-3872	1441	E-512	2214	E-712
1364	E-1025	1442	E-609	2216	E-920
1364	E-2101	1443	E-1112A	2217	E-919
1369	E-2768	1447	E-5304	2218	E-2291
1369	E-3490B	1448	E-3711	2219	E-1893
13696	E-9063	1451	E-3869	2220	E-1567
1370	E-2767	1451	E-3870	222069	E-501
1371	E-3512	1452	E-5087	2224	E-2690A
1372	E-9069	1453	E-9061	2225	E-5127
137224	E-10828	1460	E-537	2227	E-961
1373	E-3437	1462	E-1269	2230	E-2380
1374	E-3437	1463	E-1269	2231	E-1271
1375	E-9643	1465	E-1416	2232	E-2551
13751	E-9643	1470	E-563	2233	E-3447
1376	E-979	1472	E-1113	2235	E-2389
1377	E-2770	1473	E-2391	2240	E-2670
1378	E-3481A	1475	E-3427	2241	E-2407
1379	E-3490B	1477	E-3874	2242	E-2408
1380	E-3873	1478	E-3871	2244	E-3877
1381	E-5088	1480	E-538	2246	E-6080
1382	E-7232	1482	E-801	2248	E-6076
1383	E-7232	1488	E-2401	2249	E-9783
1384	E-7238	1489	E-2392	2300	E-654
1385	E-7238	1490	E-579A	2304	E-1416A
1386	E-10197	14903	E-9042	2306	E-1272
13862	E-8907	1492	E-5093	2309	E-2406

COMPETITOR INTERCHANGE

DAYTON/BATCO (cont)

DAYTON/BATCO (cont)

DAYTON/BATCO (cont)

COMPETITOR NUMBER	EUCLID NUMBER
2310	E-2405
2312	E-1416
2313	E-2405
2314	E-1314
2315	E-5128
2316	E-3469
2317	E-2717
2318	E-3878
2319	E-3878
2326	E-3859
2350	E-564
2350	E-580
2353	E-1416A
2356	E-654
2400	E-864
2507	E-3775
2507	E-886
2508	E-3775
2508	E-886
3114	E-2104
31141	E-9788A
31142	E-9787A
3115	E-2103
3125	E-2104
3126	E-2103
3131	E-1318A
3131	E-1319A
3136	E-9593
3140	E-5476
3141	E-5476
31451	E-11897
3148	E-9590
3149	E-9591
3150	E-9592
3151	E-9593
3154	E-9596
3155	E-9597
3160	E-4934A
3161	E-5241A
3162	E-5240A
3180	E-5243A
3181	E-5244A
3182	E-5242A
3183	E-9601
3184	E-9602
3200	E-535
3201	E-661
320154U	E-7524
320159U	E-7526
320159UB	E-7526
320160U	E-7499
320169UB	E-7526

COMPETITOR NUMBER	EUCLID NUMBER
320174U	E-8656
320175U	E-7525
3202	E-1385
3205	E-1318A
3206	E-1571
3207	E-1577A
3207	E-4594
3208	E-2102
3209	E-1318A
3210	E-2517
3212	E-2361
321299	E-9321
3213	E-1314
3214	E-2695
3250	E-603
325181U	E-7499
325182U	E-7497
3258	E-1319A
3259	E-1319A
3260	E-1319A
3260	E-2477B
3261	E-1319A
3264	E-4594
3266	E-4593
3268	E-4586
3270	E-4594
3271	E-4593
3272	E-4587
3273	E-4586
329101U	E-7458
329102U	E-8919
329103U	E-7459
329104U	E-7507
329105U	E-8927
329106U	E-7483
329108U	E-9507
329109U	E-7477
329110U	E-7440
329111U	E-7439
329112U	E-7482
329113U	E-7464
329114U	E-7641
329115U	E-7430
329116U	E-7431
329117U	E-8650
329118U	E-7643
329119U	E-7644
329120U	E-7640
329121U	E-7527
329123U	E-7451
329124U	E-7451
329127U	E-7505

COMPETITOR NUMBER	EUCLID NUMBER
329128U	E-7471
329129U	E-7467
329130U	E-7508
329131U	E-7502
329132U	E-7503
329133U	E-7484
329134U	E-7504
329135U	E-7473
329136U	E-7472
329137U	E-7460
329138U	E-7461
329139U	E-8652
329141U	E-7469
329142U	E-7470
329143U	E-7468
329144U	E-7506
329145U	E-7466
329145U	E-7467
329147U	E-7462
329148U	E-7465
329149U	E-7448
329150U	E-8918
329151U	E-7507
329157U	E-7445
329177U	E-7484
329199U	E-11853
334206	E-937
334475	E-1307
334679	E-5529
334936	E-9575
392149U	E-7448
4047	E-9661
4050	E-9660
4051	E-9659
4052	E-9650
4057	E-9647
4064	E-9662
4090	E-3517
4091	E-3516
4100	E-4716
4103	E-2796
4104	E-1095
4105	E-1094
4108	E-9090
4109	E-9089
4110	E-684
4111	E-685
4116	E-2413
4117	E-2412
4132	E-2794
4133	E-2795
4142	E-9692A

COMPETITOR INTERCHANGE

DAYTON/BATCO (cont)		DAYTON/BATCO (cont)		DAYTON/BATCO (cont)	
COMPETITOR NUMBER	EUCLID NUMBER	COMPETITOR NUMBER	EUCLID NUMBER	COMPETITOR NUMBER	EUCLID NUMBER
4143	E-9691A	4210931	E-5529	4320	E-2411A
4144	E-4708B	4210931	E-5530	4321	E-6077
4145	E-4709B	4210932	E-5529	4322	E-3479
4150762	E-5058	4210961	E-9712	4327	E-2404
4150811	E-5130	4210962	E-9711	4328	E-2409
4150811	E-5138	4216	E-1410	4334	E-3478
4150812	E-5129	4217	E-1411	4338	E-9071
4150861	E-5061	4218	E-1420	4339	E-3473
4150862	E-5060	4219	E-1421	4340	E-3471
4150911	E-5067	4220	E-1423	4341	E-3472
4150912	E-5066	4221	E-1422	4345	E-3475
4150931	E-5132	4222	E-1393	4347	E-2733
4150932	E-5131	4223	E-1394	4347	E-3476
4150961	E-5134	4230941	E-9716	4350	E-5137
4150962	E-5133	4230942	E-9715	4351	E-5138
4151001	E-5136	4240	E-2492	4356	E-9076
4151002	E-5135	4240761	E-1089	4357	E-5482
4151111	E-5063	4240762	E-1090	4358	E-2411A
4151112	E-5062	4240901	E-4996	4359	E-9073
4156	E-1788	4240902	E-4995	4361	E-9074
4157	E-1789	4241	E-2493	4362	E-9075
4160811	E-9029	4260931	E-9065	4363	E-9077
4160812	E-9028	4260931	E-9066	4370861	E-2799
4160931	E-9031	4260932	E-9065	4370862	E-2800
4160932	E-9030	4260932	E-9066	4371021	E-9764
4160961	E-9033	4264	E-1776	4371022	E-9763
4160962	E-9032	4265	E-1775	4371051	E-4887
4161001	E-9035	4266	E-2799	4371052	E-4886
4161002	E-9034	4267	E-2800	4371121	E-9766
4168	E-2714A	4268	E-2786	4371122	E-9765
4180	E-1089	4269	E-2787	4371151	E-1775
4181	E-1090	4274	E-3524	4371152	E-1776
4190811	E-3461	4275	E-3523	4371251	E-2786
4190812	E-3460	4278	E-1564	4371252	E-2787
4190851	E-4917	4279	E-1563	4371311	E-4889
4190852	E-4916	4280	E-2100	4371312	E-4888
4190931	E-4919	4281	E-2099	4371351	E-4741
4190932	E-4918	4300	E-656	4371352	E-4740
4198	E-2108	4301	E-581	4371431	E-3524
4199	E-2107	4302	E-580	4371432	E-3523
4200771	E-4913	4303	E-719	4390861	E-5491
4200771	E-9694	4304	E-1565	4390862	E-5490
4200772	E-4912	4306	E-1408	4391051	E-9768
4200772	E-9693	4307	E-1782	4391052	E-9767
4200811	E-9696	4307	E-580	4391161	E-5493
4200812	E-9695	4308	E-1781	4391162	E-5492
4200961	E-9702	4309	E-1113	4391251	E-9770
4200962	E-9701	4310	E-526	4391252	E-9769
4202	E-2694	4314	E-910	4391441	E-9772
4203	E-2694	4315	E-1569	4391442	E-9771
4210851	E-9708	4318	E-4736	4410531	E-10864
4210852	E-9707	4319	E-3234	4410532	E-10863

COMPETITOR INTERCHANGE

DAYTON/BATCO (cont)

COMPETITOR NUMBER	EUCLID NUMBER
4410621	E-10860
4410622	E-10859
4410771	E-10861
4410772	E-10862
4450521	E-10896
4450522	E-10895
4450651	E-4707B
4450652	E-4705B
4450811	E-4706B
4450812	E-4707B
4450821	E-5056
4450822	E-5057
4450861	E-2478B
4450862	E-2479B
4450921	E-9688
4450921	E-9688A
4450922	E-9687A
4450922	E-9687A
4451031	E-1788
4451032	E-1789
4451051	E-2700B
4451052	E-2701B
4451121	E-1773C
4451122	E-1774C
4451151	E-1147C
4451152	E-1148C
4451171	E-4702B
4451172	E-4703B
4451221	E-2714A
4451222	E-2715A
4451251	E-4708B
4451252	E-4709B
4451371	E-9690A
4451371	E-9690A
4451372	E-9689A
4451372	E-9689A
4451501	E-9692A
4451501	E-9692A
4451502	E-9691A
4451502	E-9691A
4451561	E-4710B
4451562	E-4711B
4460821	E-9648
4460822	E-9647
4460851	E-9650
4460852	E-9649
4460921	E-9652
4460922	E-9651
4460951	E-9654
4460952	E-9653
4461051	E-9656
4461052	E-9655

DAYTON/BATCO (cont)

COMPETITOR NUMBER	EUCLID NUMBER
4461101	E-9658
4461102	E-9657
4461121	E-9660
4461121	E-9660
4461122	E-9659
44611311	E-9670
4461151	E-9662
4461152	E-9661
4461161	E-9664
4461162	E-9663
4461251	E-9668
4461252	E-9667
4461311	E-9670
4461312	E-9669
4461331	E-9672
4461332	E-9671
4461351	E-4732A
4461352	E-4733A
4461352	E-9673A
4461421	E-9676
4461422	E-9675
4461461	E-9678
4461462	E-9677
4461531	E-9682
4461532	E-9681
4480771	E-9646
4480772	E-9645
4481031	E-5505A
4481032	E-5504A
4481041	E-9656
4481042	E-9655
4481121	E-9660
4481121	E-9660
4481122	E-9659
4481122	E-9659
4481151	E-9662
4481152	E-9661
4481211	E-9666
4481212	E-9665
4481331	E-9672
4481332	E-9671
4481341	E-9674A
4481342	E-9673A
4481351	E-9674A
4481352	E-9673A
4481421	E-9676
4481422	E-9675
4481471	E-9680
4481472	E-9679
4481531	E-9682
4481532	E-9681
4506	E-5507

DAYTON/BATCO (cont)

COMPETITOR NUMBER	EUCLID NUMBER
4542321	E-10906
4542322	E-10905
4561741	E-9732
4561742	E-9731
4562041	E-9734
4562042	E-9733
4562301	E-11859
4562302	E-11858
4562351	E-9735
4562352	E-9736
4562411	E-10910
4562412	E-10909
4562631	E-11861
4562632	E-11860
4571561	E-9710
4571562	E-9709
4571631	E-4712
4571632	E-4713
4571651	E-686
4571652	E-687
4571741	E-2794
4571742	E-2795
4571761	E-4714
4571761	E-4714A
4571762	E-4715
4571762	E-4715A
4571841	E-688A
4571842	E-689
4571842	E-689A
4571861	E-2412
4571861	E-2412A
4571862	E-2413
4571862	E-2413A
4572041	E-1424A
4572041	E-556
4572042	E-1425A
4572042	E-557
4572111	E-684
4572112	E-685
4572241	E-690
4572241	E-9090
4572242	E-691
4572242	E-9089
4572301	E-4885
4572302	E-4884
4572351	E-1094
4572352	E-1095
4572411	E-4716
4572412	E-4717
4572441	E-2796
4572442	E-2797
4572571	E-4718

COMPETITOR INTERCHANGE

DAYTON/BATCO (cont)		DAYTON/BATCO (cont)		DAYTON/BATCO (cont)	
COMPETITOR NUMBER	EUCLID NUMBER	COMPETITOR NUMBER	EUCLID NUMBER	COMPETITOR NUMBER	EUCLID NUMBER
4572572	E-4719	4631741	E-9752	4742361	E-9060
4572651	E-7218	4631742	E-9751	4742362	E-9059
4572652	E-7217	4631811	E-9750	4772041	E-2108
4574741	E-2794	4631812	E-9749	4772042	E-2107
4581741	E-9726	4631901	E-9266	4782031	E-1393
4581742	E-9725	4631902	E-9265	4782032	E-1394
4582041	E-3855	4632051	E-9268	4782231	E-2492
4582042	E-3854	4632052	E-9267	4782232	E-2493
4582271	E-6885	4632131	E-9270	4811621	E-1564
4582272	E-6884	4632132	E-9269	4811622	E-1563
4582351	E-3857	4632211	E-9272	4812121	E-2100
4582352	E-3856	4632212	E-9271	4812122	E-2099
4591741	E-5517	4632321	E-9274	4812401	E-3862
4591742	E-5516	4632322	E-9273	4812402	E-3861
4592041	E-5519	4632401	E-9278	4821621	E-9762
4592042	E-5518	4632402	E-9277	4821622	E-9761
4592301	E-6102	4632631	E-9280	4832121	E-4891
4592302	E-6101	4632632	E-9279	4832122	E-4890
4592351	E-5521	4642041	E-9754	4871121	E-11867
4592352	E-5520	4642042	E-9753	4871122	E-11866
4592411	E-9728	4642131	E-9756	4881731	E-2448A
4592412	E-9727	4642132	E-9755	4881732	E-2447A
4601741	E-5523	4642211	E-9758	4882041	E-2450A
4601742	E-5522	4642212	E-9757	4882042	E-2449A
4602041	E-5525	4642321	E-9760	4882421	E-2452A
4602042	E-5524	4642322	E-9759	4882422	E-2451A
4602301	E-9099	4671641	E-10918	4891731	E-2442B
4602302	E-9098	4671642	E-10917	4891732	E-2441B
4602351	E-5527	4672031	E-10920	4892041	E-2444B
4602352	E-5526	4672032	E-10919	4892042	E-2443B
4602411	E-9101	4672121	E-10922	4892421	E-2446B
4602412	E-9100	4672122	E-10921	4892422	E-2445B
4602701	E-9730	4672231	E-10924	4911731	E-5507
4602702	E-9729	4672232	E-10923	4911732	E-5506
4611901	E-9744	4672341	E-10926	4912041	E-5509
4611902	E-9743	4672342	E-10925	4912042	E-5508
4612051	E-5097	4672471	E-10928	4912421	E-5511
4612052	E-5096	4672472	E-10927	4912422	E-5510
4612121	E-1410	4672651	E-10930	4931731	E-5507
4612122	E-1411	4672652	E-10929	4931732	E-5506
4612211	E-9746	4711951	E-2694	4932041	E-5509
4612212	E-9745	4711952	E-2693	4932042	E-5508
4612321	E-1422	4712371	E-4720	4932421	E-5511
4612322	E-1423	4712372	E-4721	4932422	E-5510
4612401	E-1420	4722021	E-4722	4942041	E-4901
4612402	E-1421	4722022	E-4723	4942042	E-4900
4612461	E-2792	4731941	E-5495	4952041	E-3517
4612462	E-2793	4731942	E-5494	4952042	E-3516
4612651	E-9748	4732361	E-5496	4952331	E-9088
4612652	E-9747	4732362	E-5497	4952332	E-9087
4631621	E-9264	4741941	E-9058	5201	E-940HD
4631622	E-9263	4741942	E-9057	5202	E-612HD

COMPETITOR INTERCHANGE

DAYTON/BATCO (cont)

DAYTON/BATCO (cont)

DAYTON/BATCO (cont)

COMPETITOR NUMBER	EUCLID NUMBER
5203	E-612HD
5210	E-2307
5214	E-4904S
5224	E-2668
5225	E-2669
5233	E-2763
5234	E-2760
5237	E-2459HD
5238	E-2458HD
5240	E-1574HD
5250	E-2091
5251	E-5498
5260	E-612HD
5261	E-940HD
5262	E-2458HD
5263	E-2459HD
5264	E-1574HD
7103	E-1457
7105	E-2689
7107	E-1139
7115	E-3495
7121	E-2522
7123	E-3525
7134	E-1140
7136	E-1458
7137	E-2476
7138	E-2476
7150	E-2140
7151	E-1261
7152	E-2141
7153	E-2142
7163	E-2484
7168	E-3492
7169	E-2484
7173	E-3994
717338	E-10197
7174	E-3995
7179	E-5532
7187	E-3499
7191	E-3997
7192	E-3998
7193	E-3999
7200	E-5537
7201	E-5538
7210	E-2135
7211	E-2134
7212	E-1137
7213	E-1136
7214	E-2137
7215	E-2136
7216	E-2139
7217	E-2138

COMPETITOR NUMBER	EUCLID NUMBER
7230	E-3996
7231	E-3997
7232	E-3998
7233	E-3999
7246	E-5541
7256	E-5540
7260	E-2193
7270	E-5540
7524	E-2552
7535	E-2163
7537	E-2745
7551	E-2154
7552	E-2155
7553	E-2156
7554	E-2153
7570	E-2281
7574	E-1214
7585	E-1216
7586	E-1217
7587	E-1215
7590	E-1218
7595	E-1230
7600	E-2161
7601	E-2162
771394	E-1112A
7900	E-1128
7906	E-1262
7907	E-1735
7909	E-2290
7930	E-2015
7931	E-2015
81003	E-1816S
8100305	E-1816HD
8100305	E-4515PHD
8100360	E-1816SHD
8100360	E-4515PHD
81004	E-1816SHD
81006	E-2121
8100600	E-2121
8100660	E-2121HD
81035	E-1816SHD
81035	E-4515PHD
8104200	E-1887ASHD
8104200	E-4311EHD-N
8104230	E-2820
81047	E-1816S
81047	E-4515P
8104700	E-10875
8105100	E-5306
8105105	E-3782
81053	E-2820
81073	E-2030HD

COMPETITOR NUMBER	EUCLID NUMBER
8107300	E-2030HD
8107400	E-2402HD
8107401	E-3373HD
8107500	E-1357A
8107500	E-2403HD
8107501	E-3374HD
81076	E-2126
8107600	E-2126
81077	E-2286
8107700	E-2286
8108110	E-2676
8108260	E-1607HD
8108300	E-2675HD
8108400	E-2713
81088	E-2769S
8108801	E-2769S
8108801	E-4515Q-N
8108805	E-2769S
8108805	E-4515Q-N
8108810	E-6999S
8108812	E-3895S
8108812	E-4515U
8108815	E-6999S
8108817	E-3895S
8108817	E-4515U
8108845	E-6999SHD
8108847	E-3895SHD
8108847	E-4515UHD
8108865	E-2769HD
8108865	E-2769SHD
8108865	E-4515QHD-N
8108875	E-2769HD
8108875	E-4515QHD-N
8109000	E-4880S
8109030	E-4880SHD
8109100	E-3710S
8109100	E-4515X
8109105	E-3710S
8109105	E-4515X
8109130	E-3710HD
8109130	E-4515XHD
8109134	E-3710HD
8109134	E-4515XHD
8109135	E-3710SHD
8109135	E-4515XHD
8109165	E-3710HD
8109165	E-3710SHD
8109165	E-4515XHD
8109300	E-3484
8109500	E-5499
8109560	E-5499
8109600	E-2821

COMPETITOR INTERCHANGE

DAYTON/BATCO (cont)	
COMPETITOR NUMBER	EUCLID NUMBER
8109800	E-3992
8109830	E-3518
8109900	E-3291
8110200	E-2740
8110700	E-1308T
8110700	E-4691
8110800	E-4692
81109	E-4692
81111	E-3869
8111100	E-1308Q
8111100	E-3869
8111102	E-1308Q
8111102	E-7899
8111200	E-1308Q
8111200	E-7899
8111300	E-1308E
8111300	E-5139
81115	E-5086
8111500	E-5086
8111600	E-9644
8111630	E-9644
81122	E-1887AHD
81122	E-4311EHD-N
81124	E-2121HD
81126	E-2769HD
81126	E-4515QHD-N
81127	E-4880SHD
81136	E-3710HD
81136	E-3710SHD
81136	E-4515XHD
8113700	E-9142
8114000	E-7231
8114200	E-7237
8114800	E-4709ES-N
8114800	E-5481A
8114900	E-10756
8114920	E-10760
8115400	E-8925
8115600	E-9052
8115700	E-9048
8115800	E-8923
81160	E-9064
8116000	E-4702-KT
8116000	E-9064
8116200	E-5515
8125102	E-10866A
8125300	E-10870
81301	E-2088A
8130100	E-2363
8130101	E-2363
8130122	E-1357A
8130132	E-2089

DAYTON/BATCO (cont)	
COMPETITOR NUMBER	EUCLID NUMBER
8130200	E-2086B
8130300	E-9791HD
8130301	E-9791HD
81306	E-2382
8130600	E-2282
8130600	E-2382
8130601	E-3520A
8130610	E-6078
8130611	E-9079HD
81308	E-2089
8130800	E-2089
8130800	E-2123
81311	E-2363
81318	E-3993B
8131800	E-3993B
81321	E-2287
8132100	E-2287
8132103	E-2087
8132111	E-2680
8132300	E-2469
81325	E-2680
8132800	E-9790A
8132803	E-9790A
8132850	E-9790A
81330	E-2122
81331	E-2090
8133100	E-2090
8133101	E-2122
8133150	E-2090-2
8133151	E-2122-2
81341	E-2469
8134100	E-2526
81351	E-2125
8135100	E-2125
8135110	E-9053
81361	E-3876
8136100	E-3876
81364	E-2696A
8136400	E-2696A
81366	E-2494
8136600	E-2494
81368	E-3468A
8136800	E-3468A
81369	E-3446
8136900	E-3446
8137000	E-3353A
8137100	E-3354
8137300	E-9080
8137500	E-5140
81376	E-3520A
8137800	E-7235
8140500	E-10846

DAYTON/BATCO (cont)	
COMPETITOR NUMBER	EUCLID NUMBER
8140600	E-10868
8140601	E-10871
81700	E-6999S
81701	E-6999SHD
81702	E-2769S
81702	E-4515Q-N
81703	E-2769SHD
81703	E-4515QHD-N
81704	E-3895SHD
81704	E-4515UHD
81709	E-1887ASHD
81709	E-4311EHD-N
81711	E-4880SHD
81713	E-3710SHD
81713	E-4515XHD
81716	E-1816S
81716	E-4515P
81717	E-1816SHD
81717	E-4515PHD
81850	E-2086B
81900	E-7212A
8190020	E-7212A
8190921	E-1909
8190921	E-7214A
8190922	E-7213A
8191021	E-7213A
81919	E-5543
8191902	E-5543
8193200	E-2157
8193205	E-1934
8193303	E-2158
81934	E-2746
SEENOTE	E-4594
SEENOTE	E-7232
SEENOTE	E-7238
SEENOTE	E-943
DEXTER	
COMPETITOR NUMBER	EUCLID NUMBER
03418800	E-10921
03418801	E-10917
03418803	E-10923
03418804	E-10919
03418805	E-10925
03418809	E-10929
03418811	E-10927
03418900	E-10922
03418901	E-10918
03418903	E-10924
03418904	E-10920
03418905	E-10926
03418909	E-10930

COMPETITOR INTERCHANGE

DEXTER (cont)		EATON (cont)		EATON (cont)	
COMPETITOR NUMBER	EUCLID NUMBER	COMPETITOR NUMBER	EUCLID NUMBER	COMPETITOR NUMBER	EUCLID NUMBER
03418911	E-10928	1003017	E-2801	123574	E-1816S
3418800	E-10921	1003817	E-1400	123939	E-1816SHD
3418801	E-10917	1003817	E-2785	124305	E-2121
3418803	E-10923	1003831	E-2802	125030	E-4721
3418804	E-10919	1003832	E-2803	125031	E-4720
3418805	E-10925	1003999	E-5122	125034	E-2693
3418809	E-10929	1005006	E-2821	125035	E-2694
3418811	E-10927	100503	E-5137	125042	E-4723
3418900	E-10922	1005202	E-5137	125043	E-4722
3418901	E-10918	1005203	E-5138	125766	E-2402HD
3418903	E-10924	1005204	E-3421A	126131	E-2769S
3418904	E-10920	1005840	E-5126	126131	E-4515Q-N
3418905	E-10926	1005846	E-5128	126496	E-4880S
3418909	E-10930	1006500	E-5124	126861	E-3710S
3418911	E-10928	1006530	E-5127	127258	E-1357A
40164	E-9025	1006534	E-5125	127623	E-2088A
40165	E-9026	1006562	E-5123	127808	E-2125
40174	E-10878	1006724	E-5058	127808	E-5501
40320	E-10878	1006725	E-5059	128353	E-2382
40321	E-10876	1006726	E-5129	128719	E-2363
40322	E-10877	1006727	E-5130	129449	E-2469
K7110100	E-2469	1006728	E-5133	129814	E-2680
K7113500	E-2287	1006729	E-5134	130180	E-2122
K7113600	E-2769HD	1006730	E-5060	130545	E-2090
EATON		1006731	E-5061	130910	E-5140
COMPETITOR NUMBER	EUCLID NUMBER	1006864	E-5062	131275	E-2125
039074	E-2217A	1006865	E-5063	131275	E-5501
039074	E-595	1006866	E-5131	131520	E-596A
039075	E-596A	1006867	E-5132	16915	E-689
1000035	E-536	1006940	E-5135	178056	E-2478B
1000087	E-2800	1006941	E-5136	178422	E-2479B
1000088	E-2799	1008006	E-5066	178787	E-2799
1000091	E-2804	1008007	E-5067	179152	E-2800
1000092	E-2805	1008047	E-1416A	180248	E-1147C
1000382	E-2803	1008220	E-5127	180613	E-1148C
1000406	E-2475	1008306	E-5139	180978	E-1775
1000462	E-2807	100831	E-2802	181344	E-1776
1000463	E-2807	1008325	E-5140	182439	E-2786
1000839	E-4888	1008347	E-2696A	182805	E-2787
1000840	E-4889	1008412	E-2690A	183170	E-686
1001238	E-1887AHD	100869	E-1781	183535	E-687
1001238	E-1887ASHD	101234	E-1782	183900	E-688A
100138	E-3234	101964	E-656	184266	E-689A
1001580	E-3523	102330	E-1113	184631	E-2412A
1001581	E-3524	102330	E-564	184996	E-2413A
1001955	E-2819	102695	E-580	18504	E-9650
1002248	E-2690A	103425	E-1565	18505	E-9649
1002254	E-3520A	104521	E-526	18516	E-9660
1002262	E-2695	104886	E-1569	18517	E-9659
1002279	E-2405	105617	E-2411A	185361	E-2693
1003000	E-667	105982	E-3479	185361	E-5494
		106713	E-3478	185727	E-2694

COMPETITOR INTERCHANGE

EATON (cont)		EATON (cont)		EATON (cont)	
COMPETITOR NUMBER	EUCLID NUMBER	COMPETITOR NUMBER	EUCLID NUMBER	COMPETITOR NUMBER	EUCLID NUMBER
185727	E-5495	2-2123	E-1418	314147	E-10244
186092	E-1393	2-2124	E-2767	314147	E-10244S
186457	E-1394	2-2125	E-5122	317166	E-6924B
186822	E-1424A	22126	E-609	3-2106	E-5138
187188	E-1425A	2-2127	E-1112A	32144	E-5093
188283	E-2449A	2-2128	E-512	3-2147	E-759
188649	E-2450A	2-2129	E-2390	3-2149	E-536
189014	E-684	2-2131	E-2773	3-2150	E-1567
189379	E-685	2-2132	E-3711	3-2151	E-2380
189744	E-1410	2-2133	E-1269	3-2152	E-1271
190110	E-1411	2-2134	E-564	3-2153	E-2407
190475	E-2492	22135	E-2391	3-2154	E-2408
190840	E-2493	2-2136	E-527	3-2155	E-535
191205	E-1422	2-2137	E-801	3-2156	E-1318A
191571	E-1423	2-2138	E-2392	3-2157	E-1571
191936	E-1094	2-2139	E-579A	3-2158	E-1577A
191936	E-4716	2-2141	E-920	3-2159	E-2102
192301	E-1095	2-2142	E-1893	3-2160	E-2517
192301	E-4717	22143	E-2389	3-2161	E-2361
193397	E-2451A	2-2260	E-596A	3-2162	E-1314
193762	E-2452A	22261	E-2396	3-2163	E-536
194127	E-2796	23470	E-1781	3-2164	E-5127
194493	E-2797	23570	E-1781	3-2165	E-654
194858	E-9659	2-3685	E-2475	3-2166	E-1272
195223	E-9660	2-3685	E-2785	3-2167	E-2405
197049	E-2443B	2-3688	E-2802	3-2168	E-2406
197415	E-2444B	2-3689	E-2804	3-2169	E-1416
197780	E-2445B	2806234	E-5477	32172	E-1416
198145	E-2446B	2806235	E-10197	3-2173	E-5128
198510	E-1563	2806380	E-5482	3-2174	E-3234
198876	E-1564	2807928	E-564	3-2175	E-5137
199971	E-2099	2807929	E-801	3-2176	E-1781
200337	E-2100	2808058	E-3007A	3-2177	E-1782
219316	E-1424A	2808058	E-3227	3-2179	E-656
219317	E-1425A	2808058	E-5478	3-2180	E-1113
2-2107	E-2177	2809506	E-1893	3-2180	E-564
2-2108	E-2217A	2809507	E-920	3-2181	E-580
2-2108	E-595	2809512	E-747	3-2183	E-1565
2-2109	E-2395	2809513	E-2767	3-2186	E-526
2-2110	E-3421A	2818278	E-10197	3-2187	E-1569
2-2111	E-539	294446	E-2551	3-2189	E-2411A
2-2112	E-3227	295269	E-2679A	3-2190	E-3479
2-2113	E-3007A	295634	E-2526	3-2192	E-3478
2-2114	E-2399	295999	E-3520A	3-2706	E-2551
2-2115	E-747	296272	E-719	3-2711	E-719
2-2116	E-5123	296730	E-2087	3-2714	E-2690A
2-2117	E-545A	297095	E-2287	3-2715	E-2695
2-2118	E-1880B	297368	E-2690A	3-2716	E-910
2-2119	E-3228	297733	E-2695	32717	E-2405
2-2120	E-2768	298099	E-910	34528	E-1782
2-2121	E-2398	298921	E-2696A	35428	E-1782
2-2122	E-1428A	314146	E-10760	35430	E-9055

COMPETITOR INTERCHANGE

EATON (cont)

EATON (cont)

EATON (cont)

COMPETITOR NUMBER	EUCLID NUMBER
35431	E-9056
35455	E-4740
35456	E-4741
39074	E-2217A
39074	E-595
39075	E-596A
40547	E-9763
40548	E-9764
40864	E-1416A
43943	E-580
44672E	E-937
4514EZT	E-3304
4515ET	E-2241
4515EZFX	E-3920
4515EZT	E-2778
4524EZT	E-3303
45530	E-9765
45531	E-9766
4591S	E-2394
518401	E-8925
519132	E-8923
5-2238	E-1816S
52238B	E-1816S
5-2239	E-1816SHD
52239B	E-1816SHD
5-2240	E-2121
52240B	E-2121
5-2242	E-5139
52242B	E-5139
52243	E-1887ASHD
52243B	E-1887ASHD
5-2244	E-2402HD
52244B	E-2402HD
5-2245	E-2769S
52245B	E-2769S
52245B	E-4515Q-N
5-2246	E-4880S
52246B	E-4880S
5-2247	E-3710S
52247B	E-3710S
5-3319	E-8925
5-3321	E-8923
5-3387	E-4691
5-3690	E-2820
54142	E-1777
54152	E-1777
54153	E-1778
543238	E-4691
5808330	E-5481A
5808330B	E-5481A
61576	E-612HD
61941	E-2458HD

COMPETITOR NUMBER	EUCLID NUMBER
6-2248	E-1357A
6-2249	E-2088A
62250	E-2086B
6-2251	E-2382
6-2252	E-2363
62253	E-3993B
6-2254	E-2469
6-2255	E-2680
6-2256	E-2122
6-2257	E-2090
6-2258	E-5140
6-2259	E-2125
6-2259	E-5501
62306	E-1574HD
6-2708	E-2679A
62709	E-2469
6-2709	E-2526
6-2710	E-3520A
6-2712	E-2087
6-2713	E-2287
6-2718	E-2696A
63402	E-612HD
63767	E-940HD
64132	E-2760
651992	E-2475
651992	E-2785
65228	E-2763
653087	E-2802
653453	E-2804
653907	E-2820
655429	E-4740
655794	E-4741
65593	E-2668
656160	E-4886
656525	E-4887
657620	E-4888
657985	E-4889
658350	E-5129
658715	E-5130
659081	E-5133
659446	E-5134
65959	E-2669
659811	E-5131
660176	E-5132
660542	E-5135
660907	E-5136
66324	E-2307
70306	E-1776
70307	E-1775
70308	E-4886
70309	E-4887
70325	E-1025

COMPETITOR NUMBER	EUCLID NUMBER
70325	E-2101
70326	E-1418
71306	E-2787
71307	E-2786
72387	E-2478B
72388	E-2479B
7-2389	E-2799
7-2390	E-2800
72393	E-1147C
72394	E-1148C
7-2395	E-1775
7-2396	E-1776
72398	E-2715A
7-2399	E-2786
7-2400	E-2787
7-2401	E-686
7-2402	E-687
72403	E-688
7-2403	E-688A
72404	E-689
7-2404	E-689A
72405	E-2412
7-2405	E-2412A
72406	E-2413
7-2406	E-2413A
7-2407	E-2693
7-2407	E-5494
7-2408	E-2694
7-2408	E-5495
7-2409	E-1393
7-2410	E-1394
72411	E-1424A
72412	E-1425A
72415	E-2449A
72416	E-2450A
7-2417	E-684
7-2418	E-685
7-2419	E-1410
7-2420	E-1411
7-2421	E-2492
7-2422	E-2493
7-2423	E-1422
7-2424	E-1423
7-2425	E-1094
7-2425	E-4716
7-2426	E-1095
7-2426	E-4717
72427	E-1420
72428	E-1421
72429	E-2451A
72430	E-2452A
7-2431	E-2796

COMPETITOR INTERCHANGE

EATON (cont)		EATON (cont)		EATON (cont)	
COMPETITOR NUMBER	EUCLID NUMBER	COMPETITOR NUMBER	EUCLID NUMBER	COMPETITOR NUMBER	EUCLID NUMBER
7-2432	E-2797	78500	E-2125	808073	E-9768
72433	E-9659	78500	E-5501	808078	E-5494
72433	E-9659	78560	E-747	808078	E-9763
72434	E-9660	78580	E-1400	808079	E-5495
72434	E-9660	78580	E-1428A	808105	E-6956
72435	E-9661	78580	E-2785	808113	E-6918A
72437	E-2441B	78925	E-5123	808149	E-6918A
72438	E-2442B	79291	E-545A	808151	E-6919A
72439	E-2443B	79656	E-1880B	808152	E-6903A
72440	E-2444B	79903	E-1416A	808153	E-6934
72441	E-2445B	79933	E-2807	808154	E-6928
72442	E-2446B	80021	E-3228	808160	E-6900A
7-2443	E-1563	80386	E-2768	808161	E-6923B
7-2444	E-1564	804017	E-3234	808162	E-6924B
7-2447	E-2099	804286	E-4078	808163	E-6918A
7-2448	E-2100	804365	E-1778	808164	E-6906A
7-3694	E-4740	805442	E-1778	808165	E-6907A
7-3695	E-4741	805460	E-2819	808166	E-6925B
7-3696	E-4886	805677	E-2474	808167	E-6933
7-3697	E-4887	805678	E-1777	808168	E-6905A
7-3700	E-4888	805679	E-9509	808169	E-6927B
7-3701	E-4889	805682	E-9054	808170	E-6946
7-3702	E-5129	805897	E-1778	808171	E-6927B
7-3703	E-5130	806229	E-5480	808172	E-6936
7-3704	E-5133	806230	E-5480	808173	E-6940
7-3705	E-5134	806234	E-5477	808174	E-6942
7-3706	E-5131	806235	E-10197	808175	E-6944
7-3707	E-5132	806380	E-5482	808176	E-6924B
7-3708	E-5135	806526	E-5492	808177	E-6923B
7-3709	E-5136	806527	E-5493	808178	E-6927B
75301	E-5138	806654	E-5496	808179	E-6925B
75638	E-2177	806655	E-5497	808180	E-6924B
76003	E-2217A	807286	E-2693	808181	E-6912
76003	E-595	807287	E-2694	808182	E-6913
76293	E-9765	807304	E-4721	808184	E-6902A
76294	E-9766	807305	E-4720	808290	E-9769
76369	E-2395	80752	E-2398	808291	E-9770
76734	E-3421A	807685	E-9027	808330	E-5481A
77099	E-539	807858	E-9767	808354	E-6936
77464	E-3227	807859	E-9768	808362	E-6936
77830	E-3007A	807862	E-9771	808382	E-6936
7806526	E-5492	807863	E-9772	808688	E-6924B
7806527	E-5493	807928	E-564	808708	E-5490
7806654	E-4721	807929	E-801	808709	E-5491
7806654	E-5496	807930	E-9046	809068	E-9047
7806655	E-4720	807931	E-9043	809507	E-920
7806655	E-5497	808058	E-5478	809512	E-747
7808708	E-5490	808064	E-10913	809513	E-2767
7808709	E-5491	808065	E-10914	809610	E-10892
7810538	E-9057	808068	E-10911	809713	E-2807
7810539	E-9058	808069	E-10912	810025	E-9059
78195	E-2399	808072	E-9767	810026	E-9060

COMPETITOR INTERCHANGE

EATON (cont)

EATON (cont)

EATON (cont)

COMPETITOR NUMBER	EUCLID NUMBER
810213	E-9048
810214	E-9040
810292	E-8907
810316	E-9041
810390	E-9044
810392	E-9042
810530	E-9045
810538	E-9057
810539	E-9058
81117	E-1428A
811406	E-10915
811407	E-10916
812118	E-9052
812992	E-9038
813005	E-9036
813480	E-9030
813481	E-9031
813482	E-9032
813483	E-9033
813486	E-9028
813487	E-9029
813494	E-9034
813495	E-9035
813648	E-6944
813649	E-6942
813650	E-6947
813651	E-6946
813652	E-6940
813653	E-6936
813655	E-6940
813656	E-6928
813657	E-6934
81482	E-1418
815626	E-9039
815810	E-6951A
815811	E-6918A
815812	E-6919A
815813	E-6914A
815814	E-6900A
815815	E-6907A
815816	E-6906A
815817	E-6902A
815818	E-6982
815819	E-6981
815820	E-6903A
815821	E-6905A
816077	E-9140
817009	E-10761
817017	E-9037
818278	E-10197
818426	E-9763
81847	E-2767

COMPETITOR NUMBER	EUCLID NUMBER
818569	E-9027
818570	E-9027
819705	E-10270
819706	E-10271
819708	E-10273
819718	E-9036
819725	E-10198
819784	E-10273
820007	E-538
820007	E-801
820008	E-910
820009	E-580
820012	E-502
820063	E-527
820064	E-654
820073	E-2107
820074	E-2108
820083	E-4716
820084	E-4717
820087	E-4719
820088	E-4718
820092	E-1403
820095	E-526
820102	E-1789
820103	E-1788
820108	E-1788
820110	E-1416
820111	E-1416A
820112	E-712
820114	E-3473
820164	E-1400
820165	E-1406
820165	E-2208
820173	E-1398
820182	E-1113
820183	E-536
820185	E-1385
820196	E-1112A
820202	E-2109
820239	E-2492
820240	E-2493
820243	E-2493
820244	E-2492
820249	E-1393
820250	E-1394
820276	E-1402
8-2068	E-612HD
8-2069	E-2458HD
8-2070	E-1574HD
8-2071	E-2091
82072	E-5498
8-2073	E-612HD

COMPETITOR NUMBER	EUCLID NUMBER
8-2074	E-940HD
8-2075	E-2760
8-2078	E-2763
8-2079	E-2668
8-2080	E-2669
8-2081	E-2307
821231	E-3975
821233	E-1269
821233	E-1426
821233	E-537
821616	E-937
82213	E-5122
822157	E-2493
822158	E-2492
823141	E-9141
825422	E-9059
825424	E-9057
82943	E-1112A
83308	E-512
83674	E-2390
84404	E-2773
84769	E-3711
85135	E-1269
85500	E-564
86230	E-527
86596	E-801
86961	E-2392
87326	E-579A
88057	E-920
88422	E-1893
89695	E-2474
90276	E-759
91007	E-536
91372	E-1567
91737	E-2380
92103	E-1271
92468	E-2407
92833	E-2408
93198	E-535
93564	E-1318A
93929	E-1571
94294	E-1577A
94659	E-2102
95025	E-2517
95390	E-2361
95755	E-1314
96120	E-536
96486	E-5127
96851	E-654
97216	E-1272
974584	E-11982
974642	E-11980

COMPETITOR INTERCHANGE

EATON (cont)		EATON (cont)		EATON (cont)	
COMPETITOR NUMBER	EUCLID NUMBER	COMPETITOR NUMBER	EUCLID NUMBER	COMPETITOR NUMBER	EUCLID NUMBER
97581	E-2405	B169147	E-687	B6154	E-2218
97947	E-2406	B169148	E-686	B6154	E-541
98312	E-1416	B16915	E-689	B866	E-1402
99773	E-5128	B16915	E-689A	C2718	E-2696A
ACF00266800X	E-9061	B169155	E-4717	E1559	E-541
B1211	E-563	B169156	E-4716	E1581	E-536
B12121	E-656	B169159	E-4719	E1599	E-541
B1213	E-579A	B16916	E-688	E1661	E-527
B1214	E-538	B16916	E-688A	E1662	E-654
B1214	E-801	B169160	E-4718	E1736	E-1416A
B1215	E-910	B16919	E-691	E1738	E-712
B1216	E-580	B1705	E-1403	E5396	E-4719
B1217	E-773	B1713	E-2218	EB1000035	E-536
B1219	E-501	B1713	E-541	EB1000091	E-2804
B1220	E-2176	B17131	E-530	EB1000092	E-2805
B1220	E-500	B1716	E-526	EB1001580	E-3523
B1221	E-564	B17351	E-1789	EB1001581	E-3524
B1223	E-502	B17352	E-1788	EB1003017	E-2801
B12232	E-503	B1736	E-1416A	EB1005840	E-5126
B128310	E-690	B1738	E-712	EB1006724	E-5058
B1283100	E-688	B1740	E-3473	EB1006725	E-5059
B1283100	E-688A	B18301B	E-1398	EB1006730	E-5060
B1283101	E-691	B1969	E-504	EB1006731	E-5061
B1283102	E-690	B2010	E-1400	EB1006864	E-5062
B12839	E-691	B2011	E-2208	EB1006865	E-5063
B128399	E-689	B20121B	E-1398	EB1008006	E-5066
B128399	E-689A	B2019	E-1113	EB1008007	E-5067
B13231	E-864	B2021	E-536	EB125030	E-4721
B1559	E-2218	B2023	E-2119	EB125031	E-4720
B1559	E-541	B2028A	E-1385	EB805442	E-1778
B1581	E-536	B206023	E-2493	EB805460	E-2819
B15931	E-957	B206024	E-2492	EB805677	E-2474
B1599	E-541	B20603	E-1394	EB805678	E-1777
B1661	E-527	B206037	E-1394	EB820073	E-2107
B1662	E-654	B206038	E-1393	EB820074	E-2108
B1688A	E-3775	B20604	E-1393	EB820083	E-4716
B1688A	E-886	B206055	E-2493	EB820084	E-4717
B16911	E-2107	B206056	E-2492	EB820102	E-1788
B169110	E-690	B2076	E-1112A	EB820108	E-1789
B1691131	E-2107	B2154	E-2109	ES807772	E-8924
B1691132	E-2108	B22061B	E-2684	F169125	E-1095
B169117	E-685	B246022	E-2493	F169126	E-4885
B169118	E-684	B24603	E-1393	L229	E-3524
B16912	E-2108	B246037	E-1393	M1561	E-671
B169125	E-1095	B246037	E-1394	R2138	E-2091
B169126	E-1094	B246038	E-1393	X4212	E-3975
B169145	E-2413	B24604	E-1394	X6562	E-1269
B169145	E-689	B246055	E-2493	X6562	E-1426
B169145	E-689A	B246056	E-2492	X6562	E-537
B169146	E-2412	B246085	E-1393		
B169146	E-688	B246086	E-1394		
B169146	E-688A	B264038	E-1394		

COMPETITOR INTERCHANGE

FRUEHAUF		FRUEHAUF (cont)		FRUEHAUF (cont)	
COMPETITOR NUMBER	EUCLID NUMBER	COMPETITOR NUMBER	EUCLID NUMBER	COMPETITOR NUMBER	EUCLID NUMBER
102570	E-773	ACA003265	E-943	APA09981	E-9761
219148	E-656	ACC001996902	E-2121	APA09982	E-9762
219156	E-538	ACC001996903	E-4880S	AXA000068	E-920
219157	E-603	ACC001996903	E-4880SHD	AXA000403001	E-4586
219158	E-656	ACC001996923	E-3710HD	AXA000413900	E-1567
219160	E-526	ACC001996923	E-3710S	AXA000417001	E-1565
219162	E-502	ACC-005227-001	20415541009	AXA000418001	E-1569
219179	E-564	ACC005963900	E-1597A	AXA000420001	E-1563
219179PKG	E-564	ACD002193005	E-4891	AXA000420002	E-1564
219292	E-581	ACD002193006	E-4890	AXA000420003	E-2099
219293	E-580	ACD002193PK5	E-4891	AXA000420004	E-2100
219295	E-1269	ACD002193PK6	E-4890	AXA000420005	E-3862
219295	E-1426	ACD002227001	E-1580	AXA000420006	E-3861
219295	E-537	ACD002232001	E-1582	AXA000420900	E-2090
219296	E-563	ACD002232PK1	E-1582	AXA000429900	E-1571
219297	E-579A	ACD002233001	E-1581	AXA000429PKG	E-1571
219299	E-2218	ACD002285900	E-1577A	AXA000432001	E-580
219299	E-541	ACD002287001	E-1583	AXA000449001	E-1574HD
219300	E-500	ACD21935	E-4891	AXA001011001	E-1574HD
219310	E-1880B	ACD21936	E-4890	AXA0413900	E-1567
219310	E-545A	ACD22331	E-1581	AXA04201	E-1563
219311	E-543	ACD2285900	E-1577A	AXA04202	E-1564
219316	E-1425A	ACE006184001	E-2685	AXA04203	E-2099
219316	E-557	ACE009909001	E-2773	AXA04204	E-2100
219317	E-1424A	ACE009910001	E-523	AXA04205	E-3862
219317	E-556	ACE009911001	E-3228	AXA04206	E-3861
253395	E-527	ACE009911EX1	E-3228	AXA0429900	E-1571
254253	E-579A	ACE009911PKG	E-3228	FSP00602009	E-937
305680	E-685	ACE009911PKG	E-3490B	FSP00602PK9	E-937
305680900	E-2122	ACF000015001	E-1574HD	MBCBK0010	E-3710SHD
305681	E-684	ACF000015PK1	E-1574S-BK	MBCBK0011	E-4880SHD
330673	E-512	ACF000015PK1	E-1574HD	MBCBK0012	E-4880SHD
330733	E-2177	ACF001328001	E-3227	MBCBK0013	E-2121HD
330733	E-523	ACF003079001	E-2767	MBCBK0015	E-2286
330734	E-539	ACF003079PK1	E-2767	MBCBK0020	E-2769S
514958001	E-2685	ACF-003323-001	20415502021	MBCBK0021	E-3895S
514961900	E-2685	ACF003378001	E-3711	MBCBK0022	E-1816SHD
515147	E-536	ACF003379001	E-3920	MBCBK0024	E-3484
515148	E-535	ACF003380001	E-3713	MBCBK0030	E-1887ASHD
530596	E-943	ACF003380001	E-3714	MEY805460	E-2819
578322	E-609	ACF003380002	E-3714	MEY808708	E-5490
580443	E-1425A	ACF004021001	E-4587	MEY808709	E-5491
580443	E-557	ACF004022001	E-4587	MFAKPLOCK900	E-702A
580444	E-1424A	ACF004024001	E-4586	MHS010562	E-937
580444	E-556	ACF004024900	E-4594	MRM014250001	E-3975
583015	E-747	ACF004024902	E-4593	MRM01425001D	E-3975
61608	E-535	ACF-004362-001	E-2778	MRM01425001S	E-3975
81042	E-1887ASHD	ACF006414001	E-3490B	MRM0T5495	E-937
966691	E-3775	ACF13281	E-3227	MRMT5495D	E-937
966691	E-886	ACF40221	E-4593	MRMT5495S	E-937
966692	E-3775	APA000998001	E-9761	MRS008000	E-2769HD
966692	E-886	APA000998002	E-9762	MRS008000	E-2769S

COMPETITOR INTERCHANGE

FRUEHAUF (cont)		GUNITE		HALDEX (cont)	
COMPETITOR NUMBER	EUCLID NUMBER	COMPETITOR NUMBER	EUCLID NUMBER	COMPETITOR NUMBER	EUCLID NUMBER
MRS009001	E-1816HD	4009	E-537	40010100	E-6925B
MRS009001	E-1816SHD	4010	E-563	40010101	E-6927B
MRS061112	E-2442B	4011	E-579A	40010102	E-6923B
MRS061113	E-2441B	4023	E-544	40010103	E-6924B
MRS061878	E-1425A	AS1000	E-6923B	40010104	E-6918A
MRS061879	E-1424A	AS1000	E-6936	40010105	E-6914A
MRS062099	E-4900	AS1001	E-6925B	40010106	E-6919A
MRS062100	E-4901	AS1001	E-6942	40010140	E-6925B
MSA40010002	E-6907A	AS1003	E-6940	40010143	E-6924B
MSA40010211	E-6944	AS1003/04	E-6924B	40010144	E-6918A
MSA40010212	E-6942	AS100304	E-6924B	40010145	E-6914A
MSA40010214	E-6946	AS1004	E-6944	40010146	E-6919A
MSA40010215	E-6940	AS3001	E-9132	40010155	E-10892
MWC-B00612	E-6000A	AS3003	E-9135	40010156	E-10893
MWCX02156	E-6000A	E11398	E-11398	40010200	E-6942
SEENOTE	E-4587	HR612K	20416062003	40010201	E-6944
SEENOTE	E-943	NAR801001	E-11395	40010202	E-6936
GMC		R801001	E-11395	40010203	E-6940
COMPETITOR NUMBER	EUCLID NUMBER	R801073	E-11401	40010204	E-6946
15906936	E-8650	HALDEX		40010205	E-6947
2005774	E-7439	COMPETITOR NUMBER	EUCLID NUMBER	40010206	E-6936
2009342	E-2111A	10037	E-2307	40010211	E-6944
2009342	E-500	1850	E-612HD	40010212	E-6942
2009343	E-501	18500	E-612HD	40010213	E-6947
2095075	E-2214	18501	E-612HD	40010214	E-6946
2095075	E-505	18502	E-612HD	40010215	E-6940
2101124	E-526	18510	E-940HD	40010216	E-6936
2101126	E-564	18511	E-940HD	40010301	E-6928
2250099	E-504	18531	E-2458HD	40010303	E-6934
2277334	E-1781	18534	E-2459HD	40010304	E-6932
2291517	E-1089	18535	E-1574HD	40010305	E-6933
2291518	E-1090	18536	E-1574HD	40010306	E-6928
2295423	E-512	18536	E-1574HD	40010307	E-6934
2295551	E-2177	1855000	E-612HD	40010402	E-6951A
2295551	E-523	2100	E-612HD	40013000	E-6933
2305192	E-535	2300	E-612HD	40020211	E-11921
2309474	E-536	300634AC	E-10158	40020212	E-11922
2326940	E-2217A	300634AD	E-10158	40020213	E-11923
2326940	E-595	324095	E-2745	40020214	E-11924
2326941	E-596A	3300	E-2458HD	40020215	E-11925
2356111	E-586	40010001	E-6900A	40020216	E-11926
3772283	E-1337	40010002	E-6907A	40910051	E-6914A
3772284	E-1304	40010003	E-6906A	40910070	E-6918A
3772285	E-1305	40010004	E-6902A	40910071	E-6914A
3772286	E-980	40010005	E-6903A	40910085	E-6940
3774253	E-979	40010008	E-6905A	40910091	E-6919A
652443	E-538	40010009	E-6912	40910108	E-6903A
658049	E-580	40010010	E-6913	40910110	E-6934
702727	E-7440	40010011	E-6927B	40910111	E-6928
		40010012	E-6924B	40910114	E-6906A
		40010040	E-6982	40910115	E-6907A
		40010041	E-6981	40910124	E-6914A

COMPETITOR INTERCHANGE

HALDEX (cont)		HALDEX (cont)		HALDEX (cont)	
COMPETITOR NUMBER	EUCLID NUMBER	COMPETITOR NUMBER	EUCLID NUMBER	COMPETITOR NUMBER	EUCLID NUMBER
40910128	E-6900A	40910385	E-6902A	40910659	E-6902A
40910146	E-6918A	40910386	E-6944	40910673	E-6942
40910151	E-6933	40910391	E-6900A	40910675	E-6936
40910164	E-6913	40910392	E-6936	40910683	E-6944
40910165	E-6912	40910393	E-6936	40910749	E-6933
40910168	E-6905A	40910394	E-6940	41002	E-2478B
40910172	E-6900A	40910395	E-6940	41002	E-2479B
40910174	E-6905A	40910396	E-6942	41003	E-2478B
40910176	E-6913	40910397	E-6942	41003	E-2479B
40910177	E-6912	40910398	E-6944	41010	E-1789
40910211	E-6928	40910399	E-6944	41011	E-1788
40910218	E-6946	40910404	E-6925B	41014	E-1774C
40910222	E-6905A	40910410	E-6923B	41015	E-1773C
40910223	E-6903A	40910416	E-6927B	41016	E-1148C
40910224	E-6900A	40910417	E-6924B	41017	E-1147C
40910228	E-6905A	40910418	E-6928	41022	E-4705B
40910228	E-6919A	40910430	E-6944	41023	E-4707B
40910230	E-6936	40910432	E-6947	41024	E-4707B
40910231	E-6936	40910442	E-6914A	41025	E-4706B
40910232	E-6940	40910443	E-6918A	41026	E-2800
40910233	E-6940	40910444	E-6919A	41027	E-2799
40910234	E-6942	40910455	E-6914A	41028	E-2479B
40910235	E-6942	40910465	E-6902A	41029	E-2478B
40910238	E-6924B	40910466	E-6905A	41032	E-4886
40910240	E-6927B	40910471	E-6944	41033	E-4887
40910245	E-6928	40910472	E-6942	41034	E-2701B
40910249	E-6906A	40910473	E-6947	41035	E-2700B
40910250	E-6907A	40910474	E-6946	41036	E-4703B
40910257	E-6903A	40910475	E-6940	41037	E-4702B
40910258	E-6905A	40910476	E-6936	41040	E-2715A
40910279	E-6928	40910490	E-6932	41041	E-2714A
40910282	E-6932	40910491	E-6933	41042	E-2787
40910287	E-6914A	40910492	E-6928	41043	E-2786
40910288	E-6918A	40910493	E-6934	41044	E-4709B
40910298	E-6910	40910495	E-6900A	41045	E-4708B
40910299	E-6911	40910496	E-6902A	41046	E-4888
40910304	E-6912	40910497	E-6906A	41047	E-4889
40910305	E-6913	40910498	E-6907A	41048	E-4740
40910309	E-6951A	40910499	E-6903A	41049	E-4741
40910319	E-6902A	40910502	E-6905A	41050	E-3523
40910325	E-6906A	40910504	E-6914A	41051	E-3524
40910326	E-6907A	40910505	E-6918A	41052	E-3855
40910351	E-6947	40910529	E-6942	41053	E-3854
40910352	E-6942	40910535	E-6981	41260	E-4710B
40910361	E-6902A	40910536	E-6982	41260	E-4711B
40910362	E-6905A	40910579	E-6918A	41261	E-4710B
40910363	E-6932	40910580	E-6919A	41261	E-4711B
40910364	E-6902A	40910581	E-6914A	41264	E-687
40910365	E-6936	40910584	E-6951A	41265	E-686
40910370	E-10892	40910627	E-6924B	41266	E-2795
409-10370	E-6903A	40910649	E-6924B	41267	E-2794
40910384	E-6905A	40910655	E-6933	41268	E-4713

COMPETITOR INTERCHANGE

HALDEX (cont)		HALDEX (cont)		HALDEX (cont)	
COMPETITOR NUMBER	EUCLID NUMBER	COMPETITOR NUMBER	EUCLID NUMBER	COMPETITOR NUMBER	EUCLID NUMBER
41269	E-4712	41559	E-9658	41767	E-5130
41276	E-2447A	41560	E-9659	41768	E-5131
41277	E-2448A	41560	E-9659	41769	E-5132
41278	E-4715	41561	E-9660	41770	E-4733A
41278	E-4715A	41561	E-9660	41771	E-4732A
41279	E-4714	41562	E-9661	41772	E-5135
41279	E-4714A	41563	E-9662	41772	E-9675
41284	E-689	41564	E-9667	41773	E-5136
41284	E-689A	41565	E-9668	41773	E-9676
41285	E-688	41566	E-9669	41781	E-9696
41285	E-688A	41567	E-9670	41782	E-9699
41292	E-2693	41568	E-9671	42710422	E-6956
41293	E-2694	41569	E-9672	42710543	E-6985
41504	E-2441B	41570	E-5133	42710548	E-6956
41505	E-2442B	41571	E-5134	42710553	E-10262
41506	E-1425A	41572	E-5135	42710554	E-10894
41507	E-1424A	41573	E-5136	42710558	E-427K
41510	E-3516	41584	E-9667	42710562	E-6966A
41511	E-3517	41662	E-9661	42710565	E-6967A
41512	E-2099	41663	E-9662	42710566	E-6983
41513	E-2100	41710	E-1394	42710567	E-6984
41514	E-685	41711	E-1393	452-10125	E-452A
41515	E-684	41714	E-2493	5600	E-1574HD
41518	E-691	41715	E-2492	6200	E-612HD
41519	E-690	41718	E-1423	6300	E-940HD
41522	E-1095	41719	E-1422	6500	E-612HD
41523	E-1094	41722	E-1421	6510	E-2458HD
41524	E-4717	41723	E-1420	6512	E-2459HD
41525	E-4716	41724	E-2793	65231	E-1147C
41526	E-2443B	41725	E-2792	65300	E-500
41527	E-2444B	41728	E-1563	65301	E-501
41528	E-1563	41729	E-1564	65302	E-1269
41529	E-1564	41730	E-2099	65303	E-537
41532	E-2449A	41731	E-2100	65304	E-563
41533	E-2450A	41752	E-2451A	65305	E-538
41542	E-4884	41753	E-2452A	65306	E-541
41543	E-4885	41754	E-2797	65307	E-502
41544	E-4721	41755	E-2796	65308	E-503
41545	E-4720	41756	E-4719	65309	E-543
41546	E-4717	41757	E-4718	65310	E-544
41547	E-4716	41758	E-2445B	65311	E-527
41548	E-4723	41759	E-2446B	65313	E-564
41549	E-4722	41760	E-1776	65314	E-504
41550	E-9650	41761	E-1775	65318	E-526
41551	E-9649	41761	E-1776	65320	E-1418
41552	E-9651	41762	E-1411	65322	E-1148C
41553	E-9652	41763	E-1410	65323	E-1214
41554	E-9653	41764	E-2413	65325	E-773
41555	E-9654	41764	E-2413A	65326	E-523
41556	E-9655	41765	E-2412	65327	E-539
41557	E-9656	41765	E-2412A	65328	E-512
41558	E-9657	41766	E-5129	65329	E-536

COMPETITOR INTERCHANGE

HALDEX (cont)		HALDEX (cont)		HALDEX (cont)	
COMPETITOR NUMBER	EUCLID NUMBER	COMPETITOR NUMBER	EUCLID NUMBER	COMPETITOR NUMBER	EUCLID NUMBER
65330	E-535	65424	E-537	66646	E-2361
65331	E-579A	65425	E-671	66647	E-795
65332	E-1424A	65428	E-752	66679	E-1497
65332	E-556	65430	E-595	66680	E-1486
65333	E-1425A	65431	E-595	66681	E-3994
65333	E-557	65431	E-596A	66683	E-2390
65337	E-545A	65434	E-661	66691	E-3469
65338	E-581	65435	E-781	66692	E-3471
65339	E-580	65437	E-712	66693	E-3476
65340	E-656	65439	E-512	66697	E-3472
65344	E-609	65440	E-609	66699	E-3479
65351	E-747	65441	E-667	66735	E-1816SHD
65352	E-654	65444	E-757	66735	E-4515PHD
65356	E-2241	65448	E-919	66740	E-2122
65357	E-2685	65449	E-1880B	66740(2)	E-2122
65358	E-801	65450	E-1428A	66825	E-796
65359	E-807	65450	E-2785	66829	E-2412
65360	E-1025	65452	E-910	66829	E-2412A
65363	E-957	65453	E-1777	66829	E-688
65364	E-1095	65454	E-1139	66829	E-688A
65365	E-1094	65456	E-1778	66830	E-2413
65366	E-920	65470	E-586	66830	E-2413A
65368	E-943	65473	E-2015	66830	E-689
65369	E-1112A	65476	E-2102	66830	E-689A
65370	E-1563	65491	E-2405	66831	E-2670
65371	E-1564	65494	E-2406	66836	E-5123
65372	E-1893	65561	E-1106	66841	E-3424
65373	E-1113	65565	E-603	66859	E-2409
65374	E-719	65732	E-1893	66861	E-2769S
65375	E-2291	66439	E-1137	66862	E-2773
65376	E-3227	66440	E-1136	66863	E-2767
65377	E-1565	66447	E-1458	66864	E-2768
65378	E-1567	66544	E-1106	66865	E-4880S
65379	E-1569	66547	E-937	66866	E-2766S
65380	E-1571	66549	E-1318A	66867	E-2769SHD
65383	E-1416	66552	E-603	66869	E-2391
65384	E-759	66553	E-1410	66870	E-2392
65385	E-1140	66554	E-1411	66871	E-2395
65387	E-5541	66555	E-1788	66872	E-2396
65391	E-1128	66556	E-1789	66873	E-2389
65397	E-1136	66561	E-1108	66875	E-4880SHD
65398	E-1137	66563	E-654	66886	E-979
65400	E-1216	66565	E-3490B	6689	E-2409
65401	E-1217	66610	E-3511	66890	E-2716
65404	E-2153	66612	E-3512	66890	E-3447
65409	E-1215	66632	E-1304	66891	E-2717
65412	E-1230	66634	E-1402	66892	E-2720
65414	E-1497	66635	E-757	66894	E-2723
65417	E-2522	66636	E-1400	66898	E-2732
65421	E-608	66640	E-1140	66899	E-2733
65422	E-530	66643	E-980	66900	E-2734
65423	E-5093	66645	E-1577A	66901	E-2177

COMPETITOR INTERCHANGE

HALDEX (cont)		HALDEX (cont)		HALDEX (cont)	
COMPETITOR NUMBER	EUCLID NUMBER	COMPETITOR NUMBER	EUCLID NUMBER	COMPETITOR NUMBER	EUCLID NUMBER
66902	E-2217A	67362	E-2695	C63113	E-9789
66902	E-595	67363	E-1416A	C63137	E-4594
66903	E-3007A	67364	E-2690A	C63140	E-6076
66913	E-3710S	67365	E-1426	C63142	E-9783
66914	E-3710SHD	67366	E-2672	C63143	E-2477B
66915	E-3711	67368	E-1337	C63146	E-9076
66917	E-5139	67369	E-2726	C63148	E-9077
66918	E-5140	67370	E-2443B	C63150	E-3876
66919	E-4691	67371	E-2444B	C63153	E-9075
66920	E-3468A	67374	E-1781	C63157	E-9074
66922	E-3446	67379	E-2778	C63158	E-9072
66923	E-4692	67488	E-5305	C63163	E-5482
66926	E-3291	67489	E-5304	C63164	E-6077
67018	E-2551	67492	E-2398	C63165	E-9071
67313	E-2740	68872	E-2396	C63166	E-9073
67314	E-2713	BE22010	E-10158	C63465	E-9071
67315	E-1816S	BE22040	E-10158	C65300	E-500
67316	E-2121	C552331	E-6988A	C65301	E-501
67317	E-1816S	C63001	E-5478	C65302	E-1269
67317	E-4515P	C63005	E-10198	C-65305	E-538
67319	E-1887ASHD	C63006	E-5125	C65306	E-541
67319	E-4311EHD-N	C63007	E-5124	C65307	E-502
67324	E-2090	C63015	E-5477	C65311	E-527
67324(2)	E-2090	C63018	E-5089	C65313	E-564
67325	E-2123	C63022	E-2176	C65318	E-526
67326	E-2125	C63026	E-505	C65320	E-1418
67326(2)	E-2125	C63027	E-504	C65327	E-539
67327	E-2086B	C63029	E-3231	C65329	E-536
67327(2)	E-2086B	C63030	E-595	C65331	E-579A
67328	E-2088A	C63032	E-796	C65338	E-580
67328	E-2088AHD	C63037	E-2101	C65339	E-581
67328(2)	E-2088A	C63042	E-2745	C65340	E-656
67329	E-1357A	C63043	E-9063	C65344	E-609
67331	E-2087	C63045	E-9069	C65351	E-747
67332	E-2287	C63047	E-8907	C65352	E-654
67332(2)	E-2287	C63051	E-9038	C65358	E-801
67334	E-2382	C63054	E-9037	C65359	E-807
67334(2)	E-2382	C63058	E-5088	C65366	E-920
67335	E-3353A	C63060	E-10197	C65368	E-943
67336	E-3354	C63067	E-5087	C65369	E-1112A
67352	E-1816S	C63073	E-3445	C65372	E-1893S
67352	E-3354	C63083	E-530	C65373	E-1113
67352	E-4515P	C63084	E-1893	C65374	E-719
67353	E-2680	C63091	E-9042	C65375	E-2291
67353(2)	E-2680	C63097	E-2401	C65376	E-3227
67354	E-2696A	C63101	E-537	C65377	E-1565
67354(2)	E-2696A	C63102	E-563	C65378	E-1567
67356	E-2675HD	C63103	E-1426	C65379	E-1569
67357	E-1607HD	C63104	E-3877	C65380	E-1571
67358	E-2517	C63107	E-5512	C65381	E-5095
67359	E-1314	C63109	E-667	C65383	E-1416
67361	E-1385	C63112	E-6080	C65384	E-759

COMPETITOR INTERCHANGE

HALDEX (cont)		HALDEX (cont)		HALDEX (cont)	
COMPETITOR NUMBER	EUCLID NUMBER	COMPETITOR NUMBER	EUCLID NUMBER	COMPETITOR NUMBER	EUCLID NUMBER
C65414	E-2163	C66699	E-3479	C67447	E-1582
C65434	E-661	C66751	E-2029	C67448	E-1581
C65435	E-2215	C66752	E-1107	C67457	E-3234
C65437	E-712	C66753	E-1025	C67466	E-3483
C65448	E-919	C66753	E-1497	C67467	E-3482
C65449	E-1880B	C66755	E-773	C67470	E-3228
C65450	E-1428A	C66831	E-2670	C67471	E-2399
C65452	E-910	C66834	E-3421A	C67473	E-2390
C65470	E-586	C66835	E-5122	C67474	E-2391
C65476	E-2102	C66836	E-5123	C67475	E-2392
C65488	E-2404	C66837	E-5127	C67476	E-2389
C65491	E-2405	C66838	E-5128	C67487	E-2396
C65494	E-2406	C66839	E-5137	C67488	E-5305
C65561	E-1106	C66840	E-5138	C67489	E-5304
C65565	E-603	C66841	E-3424	C67490	E-2395
C65700	E-4736	C66842	E-3437	C67492	E-2398
C65750	E-3859	C66843	E-3874	C67502	E-2109
C66421	E-3991	C66847	E-3427	C67786	E-2475
C66425	E-1140	C66849	E-757	C67804	E-1408
C66447	E-1458	C66852	E-2411A	C69611	E-3870
C66455	E-2476	C66853	E-3872	C69612	E-3871
C66549	E-1318A	C66854	E-3873	CQ3373HD	E-3373HD
C66563	E-1416A	C66859	E-2409	CQ36543	E-9133
C66606	E-2805	C66862	E-2773	CQ36551	E-9132
C66607	E-2804	C66863	E-2767	CQ36552	E-9132
C66608	E-2802	C66864	E-2768	CQ36562	E-9135
C66609	E-2803	C66879	E-2798	CQ36572	E-9135
C66610	E-3511	C66880	E-2770	CQ62766	E-3876
C66611	E-3513	C66886	E-979	CQ62767	E-5086
C66612	E-3512	C66890	E-2716	CQ65446	E-10760
C66614	E-543	C66891	E-2717	CQ65477	E-10244
C66632	E-1304	C66894	E-2723	CQ65477	E-4709ES2-N
C66633	E-1305	C66895	E-2724	CQ65478	E-8923
C66643	E-980	C66896	E-2725	CQ65479	E-8925
C66645	E-1577A	C66898	E-2732	CQ65481	E-5481A
C66646	E-2361	C66899	E-2733	CQ65501	E-5501
C66647	E-795	C66901	E-2177	CQ65515	E-5515
C66649	E-1403	C66910	E-512	CQ65517	E-3989AHD
C66650	E-1406	C66911	E-523	CQ65519	E-7231
C66651	E-937	C66915	E-3711	CQ65520	E-7237
C66652	E-1402	C67001	E-3478	CQ65521	E-5499
C66653	E-1400	C67018	E-2551	CQ65642	E-9064
C66654	E-3975	C67320	E-9643	CQ66735	E-1816HD
C66690	E-3447	C67358	E-2517	CQ66735	E-1816SHD
C66691	E-3469	C67361	E-1385	CQ66735	E-4515PHD
C66692	E-3471	C67362	E-2695	CQ66740	E-2122
C66693	E-3476	C67366	E-3914	CQ66742	E-2157
C66695	E-3474	C67368	E-1337	CQ66743	E-2159
C66695	E-3475	C67369	E-2726	CQ66744	E-3525
C66696	E-3473	C67374	E-1781	CQ66759	E-4800
C66697	E-3472	C67375	E-1782	CQ66861	E-2769S
C66698	E-5093	C67446	E-1583	CQ66867	E-2769HD

COMPETITOR INTERCHANGE

HALDEX (cont)		HALDEX (cont)		HALDEX (cont)	
COMPETITOR NUMBER	EUCLID NUMBER	COMPETITOR NUMBER	EUCLID NUMBER	COMPETITOR NUMBER	EUCLID NUMBER
CQ66867	E-2769SHD	CQ67383	E-5307	CS40118	E-5529
CQ66875	E-4880SHD	CQ67384	E-2089	CS40119	E-5530
CQ66887	E-9644	CQ67385	E-2679A	CS40120	E-9715
CQ66889	E-9070	CQ67385	E-2679AHD	CS40121	E-9716
CQ66913	E-3710S	CQ67386	E-3520A	CS40122	E-4919
CQ669130	E-2158	CQ67387	E-3993B	CS40126	E-4991
CQ66914	E-3710HD	CQ67388	E-2126	CS40127	E-4992
CQ66914	E-3710SHD	CQ67394	E-2286	CS40132	E-9065
CQ669140	E-2159	CQ67395	E-3484	CS40133	E-9066
CQ66917	E-5139	CQ67396	E-5306	CS40134	E-9067
CQ66918	E-5140	CQ67397	E-2030HD	CS40134	E-9067A
CQ66919	E-4691	CQ67398	E-2402HD	CS40135	E-9068A
CQ66920	E-3468A	CQ67399	E-2121HD	CS40135	E-9068A
CQ66922	E-3446	CQ67401	E-4880S	CS40138	E-5057
CQ66923	E-4692	CQ67405	E-9281	CS40139	E-5056
CQ66926	E-3291	CQ67406	E-2821	CS40140	E-9689A
CQ66927	E-7212A	CQ67407	E-3518	CS40140	E-9689A
CQ66928	E-7213A	CQ67408	E-3992	CS40141	E-9690A
CQ66929	E-7214A	CQ67410	E-2494	CS40141	E-9690A
CQ66929B	E-7212A	CQ67411	E-2526	CS40152	E-9663
CQ66939	E-5094A	CQ67412	E-9053	CS40153	E-9664
CQ66940	E-5513	CQ67413	E-9080	CS40160	E-9677
CQ66941	E-6078	CQ67414	E-9791HD	CS40161	E-9678
CQ66947	E-9141	CQ67416	E-9079HD	CS40164	E-9681
CQ66948	E-9039	CQ67435	E-1816S	CS40165	E-9682
CQ67128	E-9078HD	CQ67435	E-4515P	CS40172	E-9645
CQ67313	E-2740	CQ67437	E-10756	CS40173	E-9646
CQ67314	E-2713	CQ67503	E-2403HD	CS40174	E-9649
CQ67316	E-2121	CQ67503B	E-2403HD	CS40175	E-9650
CQ67317	E-1816S	CQ67505	E-3374HD	CS40176	E-5504A
CQ67317	E-4515P	CQ67506	E-9282	CS40177	E-5505A
CQ67319	E-1887ASHD	CQ67899	E-7899	CS40178	E-9655
CQ67319	E-4311EHD-N	CQ68875	E-4880SHD	CS40179	E-9656
CQ67324	E-2090	CQ69001	E-3869	CS40182	E-9659
CQ67325	E-2123	CQ69002	E-3782	CS40183	E-9660
CQ67326	E-2125	CQ69003	E-6879	CS40184	E-9661
CQ67327	E-2086B	CQ69004	E-3801	CS40185	E-9662
CQ67328	E-2086B	CQ69006	E-9283	CS40186	E-9671
CQ67328	E-2088A	CQ69007	E-11981	CS40187	E-9672
CQ67328	E-2088AHD	CS40100	E-3460	CS40192	E-9675
CQ67329	E-1357A	CS40101	E-3461	CS40193	E-9676
CQ67331	E-2087	CS40102	E-4918	CS40194	E-9679
CQ67332	E-2287	CS40106	E-9695	CS40195	E-9680
CQ67334	E-2363	CS40107	E-9695	CS40196	E-9677
CQ67334	E-2382	CS40108	E-9697	CS40197	E-9678
CQ67335	E-3353A	CS40109	E-9698	CS40198	E-9681
CQ67336	E-3354	CS40110	E-9701	CS40199	E-9682
CQ67353	E-2680	CS40111	E-9702	CS41010	E-1789
CQ67354	E-2696A	CS40112	E-9713	CS41011	E-1788
CQ67356	E-2675HD	CS40113	E-9714	CS41014	E-1774C
CQ67357	E-1607HD	CS40116	E-9707	CS41015	E-1773C
CQ67382	E-2469	CS40117	E-9708	CS41016	E-1148C

COMPETITOR INTERCHANGE

HALDEX (cont)

COMPETITOR NUMBER	EUCLID NUMBER
CS41017	E-1147C
CS41022	E-4705B
CS41023	E-4707B
CS41024	E-4707B
CS41025	E-4706B
CS41026	E-2800
CS41027	E-2799
CS41028	E-2479B
CS41029	E-2478B
CS41032	E-4886
CS41033	E-4887
CS41034	E-2701B
CS41035	E-2700B
CS41036	E-4703B
CS41037	E-4702B
CS41040	E-2715A
CS41041	E-2714A
CS41042	E-2787
CS41043	E-2786
CS41044	E-4709B
CS41045	E-4708B
CS41046	E-4888
CS41047	E-4889
CS41048	E-4740
CS41049	E-4741
CS41050	E-3523
CS41051	E-3524
CS41052	E-3855
CS41053	E-3854
CS41104	E-4900
CS41105	E-4901
CS41106	E-3516
CS41107	E-3517
CS41108	E-9087
CS41109	E-9088
CS41110	E-5506
CS41111	E-5507
CS41112	E-5508
CS41113	E-5509
CS41114	E-5510
CS41115	E-5511
CS41150	E-9653
CS41151	E-9654
CS41152	E-9663
CS41153	E-9664
CS41154	E-9667
CS41155	E-9668
CS41156	E-9669
CS41157	E-9670
CS41158	E-9651
CS41159	E-9652
CS41160	E-9657

HALDEX (cont)

COMPETITOR NUMBER	EUCLID NUMBER
CS41161	E-9658
CS41162	E-2413
CS41162	E-2413A
CS41163	E-2412
CS41163	E-2412A
CS41164	E-3856
CS41165	E-3857
CS41166	E-7217
CS41167	E-7218
CS41168	E-7219
CS41169	E-7220
CS41172	E-9647
CS41173	E-9648
CS41260	E-4710B
CS41260	E-4711B
CS41261	E-4710B
CS41261	E-4711B
CS41264	E-687
CS41265	E-686
CS41266	E-2795
CS41267	E-2794
CS41268	E-4713
CS41269	E-4712
CS41276	E-2447A
CS41277	E-2448A
CS41278	E-4715
CS41278	E-4715A
CS41279	E-4714
CS41279	E-4714A
CS41284	E-689
CS41284	E-689A
CS41285	E-688
CS41285	E-688A
CS41292	E-2693
CS41293	E-2694
CS41330	E-9743
CS41331	E-9744
CS41332	E-5096
CS41333	E-5097
CS41334	E-9745
CS41335	E-9746
CS41336	E-9747
CS41337	E-9748
CS41338	E-9263
CS41339	E-9264
CS41340	E-9265
CS41341	E-9266
CS41342	E-9267
CS41343	E-9268
CS41344	E-9269
CS41345	E-9270
CS41346	E-9271

HALDEX (cont)

COMPETITOR NUMBER	EUCLID NUMBER
CS41347	E-9272
CS41348	E-9273
CS41349	E-9274
CS41350	E-9275
CS41351	E-9276
CS41352	E-9277
CS41353	E-9278
CS41354	E-9279
CS41355	E-9280
CS41358	E-9755
CS41359	E-9756
CS41360	E-9757
CS41361	E-9758
CS41362	E-9759
CS41363	E-9760
CS41380	E-9709
CS41381	E-9710
CS41388	E-5516
CS41389	E-5517
CS41390	E-5520
CS41391	E-5521
CS41392	E-9727
CS41393	E-9728
CS41394	E-9741
CS413941	E-5521
CS41395	E-9742
CS41396	E-9096
CS41397	E-9097
CS41398	E-5522
CS41399	E-5523
CS41400	E-5524
CS41401	E-5525
CS41402	E-9098
CS41403	E-9099
CS41404	E-5526
CS41405	E-5527
CS41408	E-9100
CS41409	E-9101
CS41414	E-9731
CS41415	E-9732
CS41416	E-9733
CS41417	E-9734
CS41420	E-9735
CS41421	E-9736
CS41424	E-5129
CS41425	E-5130
CS41428	E-9028
CS41429	E-9029
CS41438	E-9030
CS41439	E-9031
CS41440	E-9032
CS41441	E-9033

COMPETITOR INTERCHANGE

HALDEX (cont)		HALDEX (cont)		HALDEX (cont)	
COMPETITOR NUMBER	EUCLID NUMBER	COMPETITOR NUMBER	EUCLID NUMBER	COMPETITOR NUMBER	EUCLID NUMBER
CS41442	E-9034	CS41532	E-2449A	CS41753	E-2452A
CS41443	E-9035	CS41533	E-2450A	CS41754	E-2797
CS41444	E-11862	CS41542	E-4884	CS41755	E-2796
CS41445	E-11863	CS41543	E-4885	CS41756	E-4719
CS41446	E-9765	CS41544	E-4721	CS41757	E-4718
CS41447	E-9766	CS41545	E-4720	CS41758	E-2445B
CS41448	E-9055	CS41546	E-4717	CS41759	E-2446B
CS41449	E-9056	CS41547	E-4716	CS41760	E-1776
CS41450	E-5490	CS41548	E-4723	CS41761	E-1775
CS41451	E-5491	CS41549	E-4722	CS41761	E-1776
CS41454	E-9767	CS41550	E-9650	CS41762	E-1411
CS41455	E-9768	CS41551	E-9649	CS41763	E-1410
CS41458	E-5492	CS41552	E-9651	CS41768	E-5131
CS41459	E-5493	CS41553	E-9652	CS41769	E-5132
CS41460	E-9769	CS41554	E-9653	CS41770	E-4733A
CS41461	E-9770	CS41555	E-9654	CS41771	E-4732A
CS41466	E-9771	CS41556	E-9655	CS41772	E-5135
CS41467	E-9772	CS41557	E-9656	CS41772	E-9675
CS41474	E-2107	CS41558	E-9657	CS41773	E-5136
CS41475	E-2108	CS41559	E-9658	CS41773	E-9676
CS41476	E-5494	CS41560	E-9659	CS41906	E-9703
CS41477	E-5495	CS41560	E-9659	CS41907	E-9704
CS41478	E-5496	CS41561	E-9660	CS41910	E-4910A
CS41479	E-5497	CS41561	E-9660	CS41911	E-4911A
CS41480	E-9057	CS41562	E-9661	CS52315	E-6991A
CS41481	E-9058	CS41563	E-9662	CS52316	E-6992A
CS41482	E-9059	CS41564	E-9667	CS52320	E-6994A
CS41483	E-9060	CS41565	E-9668	CS52321	E-6993A
CS41488	E-9761	CS41566	E-9669	CS52325	E-6996A
CS41489	E-9762	CS41567	E-9670	CS52326	E-6995A
CS41492	E-3861	CS41568	E-9671	CS52330	E-6987A
CS41493	E-3862	CS41569	E-9672	CS52331	E-6988A
CS41504	E-2441B	CS41570	E-5133	CS52335	E-6989A
CS41505	E-2442B	CS41571	E-5134	CS52336	E-6990A
CS41506	E-1425A	CS41572	E-5135	CS52346	E-10780A
CS41507	E-1424A	CS41573	E-5136	CS52347	E-10779A
CS41512	E-2099	CS41692	E-9727	CS52349	E-10781A
CS41513	E-2100	CS41710	E-1394	CS52350	E-10783A
CS41514	E-685	CS41711	E-1393	CS52358	E-10784A
CS41515	E-684	CS41714	E-2493	CS52362	E-10786A
CS41518	E-691	CS41715	E-2492	CS52364	E-10785A
CS41518	E-9089	CS41718	E-1423	CS52365	E-10788A
CS41519	E-690	CS41719	E-1422	CS52366	E-10787A
CS41519	E-9090	CS41722	E-1421	CS66679	E-1497
CS41522	E-1095	CS41723	E-1420	E2769SHDR	E-2769SHD
CS41523	E-1094	CS41724	E-2793	KN44041	E-1574S-BK
CS41524	E-4717	CS41725	E-2792	KN44041	E-1574HD
CS41525	E-4716	CS41728	E-1563	KN44051	E-2458S-BK
CS41526	E-2443B	CS41729	E-1564	KN44051	E-2458HD
CS41527	E-2444B	CS41730	E-2099	KN44061	E-2459S-BK
CS41528	E-1563	CS41731	E-2100	KN44061	E-2459HD
CS41529	E-1564	CS41752	E-2451A	KN47001	E-612S-BK

COMPETITOR INTERCHANGE

HALDEX (cont)		HERCULES (cont)		HERCULES (cont)	
COMPETITOR NUMBER	EUCLID NUMBER	COMPETITOR NUMBER	EUCLID NUMBER	COMPETITOR NUMBER	EUCLID NUMBER
KN47001	E-612HD	H10006L	E-5057	H10037R	E-4702B
KN47011	E-940S-BK	H10007R	E-5056	H10037R	E-4703B
KN47012	E-6113	H10010	E-1788	H10038L	E-9709
KN47081	E-612HD	H10010L	E-1789	H10039R	E-9710
KN47081	E-612HD	H10011	E-1789	H10042	E-2786
KN48031	E-4904S	H10011R	E-1788	H10042L	E-2787
KN49010	E-2763	H10012L	E-9687A	H10043	E-2787
KN49020	E-2760	H10013R	E-9688A	H10043R	E-2786
KN51000	E-2091	H10014	E-1773C	H10044	E-4708B
KN52060	E-9105	H10014L	E-1774C	H10044L	E-4709B
KN52070	E-940HD	H10015	E-1774C	H10045	E-4709B
KN52080	E-1574HD	H10015R	E-1773C	H10045R	E-4708B
KN52100	E-612HD	H10016	E-1147C	H10046	E-4888
KN53000	E-6110	H10016L	E-1148C	H10046L	E-4888
KN53010	E-6109	H10017	E-1148C	H10047	E-4889
KN55001	E-9102	H10017R	E-1147C	H10047R	E-4889
N2943	E-2091	H10018L	E-9689A	H10052	E-3523
WKH1EZ	E-3710SHD	H10018L	E-9689A	H10052L	E-3523
WKH1EZFX	E-3710SHD	H10019L	E-9690A	H10052L	E-9765
WKH1EZT	E-2769SHD	H10019L	E-9690A	H10053	E-3524
WKH1J	E-1887ASHD	H10019R	E-9690A	H10053R	E-3524
HENDRICKSON TURNER		H10020	E-4892	H10054	E-4740
COMPETITOR NUMBER	EUCLID NUMBER	H10020L	E-4892	H10054L	E-4740
A22885	E-11451	H10021	E-4893	H10055	E-4741
B28898	E-11449	H10021R	E-4893	H10055R	E-4741
S208061L	E-10899	H10022	E-4705B	H10056L	E-9055
S208061R	E-10900	H10022L	E-4705B	H10057R	E-9056
S213991	E-6944	H10023	E-4707B	H10100L	E-1411
S213992	E-6942	H10023R	E-4704B	H10101R	E-1410
S22885	E-11451	H10023R	E-4707B	H10124L	E-5516
S22898	E-11449	H10024	E-4706B	H10125R	E-5517
S23752	E-2769HD	H10024L	E-4707B	H10126L	E-5518
S23974	E-11450	H10025	E-4707B	H10127R	E-5519
S23974	E-11450HD	H10025R	E-4706B	H10128L	E-6101
S-23974/2	E-11450HD-2	H10026	E-2799	H10129R	E-6102
S239742	E-11450HD-2	H10026L	E-2800	H10130L	E-5520
S246361L	E-11866	H10027	E-2800	H10131R	E-5521
S246361R	E-11867	H10027R	E-2799	H10148L	E-10863
S26348	E-11897	H10028L	E-9763	H10148L	E-9707
S28890	E-11897	H10029R	E-9764	H10149R	E-9708
HERCULES		H10030L	E-9765	H10150L	E-9096
COMPETITOR NUMBER	EUCLID NUMBER	H10031R	E-9766	H10151R	E-9097
H10002	E-2478B	H10032	E-4886	H10152L	E-5522
H10002L	E-2479B	H10032L	E-4886	H10153R	E-5523
H10003	E-2479B	H10033	E-4887	H10154L	E-3854
H10003R	E-2478B	H10033R	E-4887	H10154L	E-5524
H10004	E-2701B	H10034L	E-9691A	H10155R	E-3855
H10004L	E-2701B	H10035R	E-9692A	H10155R	E-5525
H10005	E-2700B	H10036	E-4702B	H10156L	E-9098
H10005R	E-2700B	H10036L	E-4702B	H10157R	E-9099
		H10036L	E-4703B	H10158L	E-3856
		H10037	E-4703B	H10158L	E-5526

COMPETITOR INTERCHANGE

HERCULES (cont)		HERCULES (cont)		HERCULES (cont)	
COMPETITOR NUMBER	EUCLID NUMBER	COMPETITOR NUMBER	EUCLID NUMBER	COMPETITOR NUMBER	EUCLID NUMBER
H10159R	E-3857	H10218L	E-5492	H10370L	E-3516
H10159R	E-5527	H10219R	E-5493	H10371R	E-3517
H10162L	E-9100	H10220L	E-9769	H10372L	E-9087
H10163R	E-9101	H10221R	E-9770	H10373R	E-9088
H10166L	E-9729	H10222L	E-9771	H10380L	E-4900
H10167R	E-9730	H10223R	E-9772	H10381R	E-4901
H10168L	E-9731	H10224L	E-9057	H10400L	E-9647
H10169R	E-9732	H10225R	E-9058	H10401R	E-9648
H10170L	E-9733	H10226L	E-9059	H10402L	E-9659
H10171R	E-9734	H10227R	E-9060	H10403R	E-9660
H10172L	E-9735	H10228L	E-5494	H10404L	E-9663
H10173R	E-9736	H10229R	E-5495	H10405R	E-9664
H10174L	E-9737	H10230L	E-5496	H10414L	E-10306A
H10175R	E-9738	H10231R	E-5497	H10415R	E-10307A
H10176L	E-10909	H10232L	E-11866	H10416L	E-9096
H10177R	E-10910	H10233R	E-11867	H10416L	E-9725
H10180L	E-9759	H10250	E-2714A	H10417R	E-9097
H10181R	E-9760	H10250L	E-2715A	H10417R	E-9726
H10182L	E-4912	H10251	E-2715A	H10418L	E-3854
H10183R	E-4913	H10251R	E-2714A	H10419R	E-3855
H10184L	E-3460	H10260	E-4711B	H10420L	E-6884
H10184L	E-3461	H10260L	E-4711B	H10421R	E-6885
H10185R	E-3461	H10261	E-4710B	H10422L	E-3856
H10186L	E-4916	H10261R	E-4710B	H10423R	E-3857
H10186L	E-9697	H10264	E-686	H10424L	E-9098
H10187R	E-4917	H10264L	E-687	H10425R	E-9099
H10187R	E-9698	H10265	E-687	H10426L	E-9100
H10188L	E-4918	H10265R	E-686	H10427R	E-9101
H10188L	E-9699	H10266	E-2794	H10430L	E-10911
H10189R	E-4919	H10266L	E-2795	H10431R	E-10912
H10189R	E-9700	H10267	E-2795	H10450L	E-9263
H10190L	E-4936	H10267R	E-2794	H10451R	E-9264
H10191R	E-4937	H10268	E-4712	H10452L	E-9751
H10192L	E-9703	H10268L	E-4713	H10453R	E-9752
H10193R	E-9704	H10269	E-4713	H10454L	E-9749
H10193R	E-9704	H10269R	E-4712	H10455R	E-9750
H10198L	E-5529	H10276	E-2447A	H10464L	E-9273
H10199R	E-5530	H10276L	E-2447A	H10465R	E-9274
H10200L	E-9711	H10277	E-2448A	H10480L	E-9753
H10201R	E-9712	H10277R	E-2448A	H10481R	E-9754
H10202L	E-9713	H10278	E-4715A	H10482L	E-9755
H10203R	E-9714	H10278L	E-4715A	H10483R	E-9756
H10204L	E-9715	H10279	E-4714A	H10484L	E-9757
H10205R	E-9716	H10279R	E-4714A	H10485R	E-9758
H10206L	E-9717	H10284	E-689A	H10486L	E-9759
H10207R	E-9718	H10284L	E-689A	H10487R	E-9760
H10214L	E-5490	H10285	E-688A	H10498L	E-10913
H10215R	E-5491	H10285R	E-688A	H10499R	E-10914
H10216L	E-5492	H10292	E-2693	H10500L	E-10915
H10216L	E-9767	H10292L	E-2693	H10501R	E-10916
H10217R	E-5493	H10293	E-2694	H10504	E-2441B
H10217R	E-9768	H10293R	E-2694	H10504L	E-2441B

COMPETITOR INTERCHANGE

HERCULES (cont)

COMPETITOR NUMBER	EUCLID NUMBER
H10505	E-2442B
H10505R	E-2442B
H10506	E-1424A
H10506L	E-1425A
H10507	E-1425A
H10507R	E-1424A
H10508	E-2107
H10509	E-2108
H10512	E-2099
H10512L	E-2099
H10513	E-2100
H10513R	E-2099
H10513R	E-2100
H10514	E-684
H10514L	E-685
H10515	E-685
H10515R	E-684
H10516	E-690
H10516L	E-691
H10517	E-691
H10517R	E-690
H10522	E-1094
H10522L	E-1095
H10523	E-1095
H10523R	E-1094
H10524	E-1420
H10525	E-1421
H10526	E-2443B
H10526L	E-2443B
H10527	E-2444B
H10527R	E-2444B
H10528	E-1563
H10528L	E-1563
H10529	E-1564
H10529R	E-1564
H10532	E-2449A
H10532L	E-2449A
H10533	E-2450A
H10533R	E-2450A
H10542	E-4884
H10542L	E-4884
H10542L	E-9089
H10543	E-4885
H10543R	E-4885
H10543R	E-9090
H10544	E-4720
H10544L	E-4721
H10545	E-4721
H10545R	E-4720
H10546	E-4716
H10546L	E-1095
H10546L	E-4717

HERCULES (cont)

COMPETITOR NUMBER	EUCLID NUMBER
H10547	E-4717
H10547R	E-1094
H10547R	E-4716
H10548	E-4722
H10548L	E-4723
H10549	E-4723
H10549R	E-4722
H10550	E-9649
H10550L	E-9649
H10550L	E-9650
H10551	E-9650
H10551R	E-9649
H10551R	E-9650
H10552	E-9651
H10552L	E-9651
H10553	E-9652
H10553R	E-9652
H10554	E-9654
H10554L	E-9654
H10555	E-9653
H10555R	E-9653
H10556	E-9655
H10556L	E-9655
H10557	E-9656
H10557R	E-9656
H10558	E-9657
H10558L	E-9657
H10559	E-9658
H10559R	E-9658
H10560	E-9659
H10560L	E-9659
H10561	E-9660
H10561R	E-9660
H10562	E-9661
H10562L	E-9661
H10563	E-9662
H10563R	E-9662
H10564	E-9667
H10564L	E-9667
H10565	E-9668
H10565R	E-9668
H10566	E-9669
H10566L	E-9669
H10567	E-9670
H10567R	E-9670
H10568	E-9672
H10568L	E-9671
H10569	E-9671
H10569R	E-9672
H10570L	E-4884
H10570L	E-9089
H10571R	E-4885

HERCULES (cont)

COMPETITOR NUMBER	EUCLID NUMBER
H10571R	E-9090
H10572L	E-7217
H10573R	E-7218
H10574L	E-7219
H10575R	E-7220
H10600L	E-5058
H10601R	E-5059
H10602L	E-5129
H10603R	E-5130
H10606L	E-5060
H10607R	E-5061
H10608L	E-5066
H10609R	E-5067
H10610L	E-5131
H10611R	E-5132
H10612L	E-5133
H10613R	E-5134
H10614L	E-5135
H10615R	E-5136
H10616L	E-5062
H10617R	E-5063
H10710	E-1393
H10711	E-1394
H10752	E-2451A
H10752L	E-2451A
H10753	E-2452A
H10753R	E-2452A
H10754	E-2796
H10754L	E-2797
H10755	E-2797
H10755R	E-2796
H10756	E-4718
H10756L	E-4719
H10757	E-4719
H10757R	E-4718
H10758	E-2445B
H10758L	E-2445B
H10759	E-2446B
H10759R	E-2446B
H10760	E-1775
H10760L	E-1776
H10761	E-1776
H10761R	E-1775
H10764	E-2412A
H10764L	E-2413A
H10765	E-2413A
H10765R	E-2412A
H10770	E-4733A
H10770L	E-4733A
H10770L	E-9673A
H10771	E-4732A
H10771R	E-4732A

COMPETITOR INTERCHANGE

HERCULES (cont)		HERCULES (cont)		HERCULES (cont)	
COMPETITOR NUMBER	EUCLID NUMBER	COMPETITOR NUMBER	EUCLID NUMBER	COMPETITOR NUMBER	EUCLID NUMBER
H10771R	E-9674A	H10864L	E-11550	H12033R	E-11867
H10772	E-9676	H10864L	E-11551	H12034L	E-11864
H10772L	E-9675	H10865R	E-11550	H12035R	E-11865
H10773	E-9675	H10865R	E-11551	H2001	E-6991A
H10773R	E-9676	H10868L	E-11567	H2002	E-6992A
H10774L	E-9677	H10869R	E-11566	H2003	E-6993A
H10775R	E-9678	H10878L	E-10901	H2004	E-6994A
H10776L	E-9681	H10879R	E-10902	H2062	E-6944
H10777R	E-9682	H10882L	E-10903	H2063	E-6942
H10778L	E-9683	H10883R	E-10904	H3030	E-10936
H10779R	E-9684	H10886L	E-10905	H3031	E-10946
H10812	E-3861	H10887R	E-10906	H3033	E-4738A
H10812L	E-3861	H10890L	E-10907	H3034	E-4739
H10813	E-3862	H10891R	E-10908	H3035	E-9590
H10813R	E-3862	H10920L	E-1090	H3036	E-9591
H10814L	E-4890	H10921R	E-1089	H3037	E-9592
H10815R	E-4891	H10924L	E-4991	H3038	E-9593
H10818L	E-9761	H10925R	E-4992	H3039	E-9594
H10819R	E-9762	H10926L	E-4993	H3040	E-10932
H10830L	E-9028	H10927R	E-4994	H3041	E-10937
H10831R	E-9029	H10928L	E-4995	H3042	E-9592
H10832L	E-9030	H10929R	E-4996	H3045	E-10931
H10833R	E-9031	H10930L	E-4997	H3050	E-9596
H10834L	E-9032	H10936L	E-10899	H3051	E-9597
H10835R	E-9033	H10937R	E-10900	H3053	E-10933
H10836L	E-9034	H10986L	E-10917	H3054	E-10934
H10837R	E-9035	H10987R	E-10918	H3056	E-4934A
H10840L	E-11521	H10990L	E-10919	H3057	E-5241A
H10841R	E-11520	H10991R	E-10920	H3058	E-5240A
H10842L	E-11523	H10992L	E-10921	H3059	E-5243A
H10843R	E-11522	H10993R	E-10922	H3060	E-5244A
H10844L	E-9065	H10994L	E-10923	H3061	E-5242A
H10845R	E-9065	H10995R	E-10924	H3062	E-9598
H10845R	E-9066	H10996L	E-10925	H3064	E-9600
H10846L	E-9067A	H10997R	E-10926	H3065	E-10944
H10847R	E-9068A	H10998L	E-10927	H3067	E-10943
H10848L	E-11538	H10999R	E-10928	H3068	E-10939
H10848L	E-11539	H11000L	E-10863	H3069	E-9601
H10849R	E-11538	H11001R	E-10864	H3070	E-9602
H10849R	E-11539	H11002L	E-10859	H3072	E-10940
H10850L	E-11548	H11003R	E-10860	H3073	E-10942
H10850L	E-11549	H11008L	E-10862	H3074	E-10945
H10851R	E-11548	H11009R	E-10861	H3102	E-8906
H10851R	E-11549	H11024L	E-11527	H3103	E-10947
H10854L	E-5506	H11025R	E-11526	H3901	E-4935
H10855R	E-5507	H11028L	E-10895	H8602	E-759
H10856L	E-5508	H11029R	E-10896	H8643	E-1357A
H10857R	E-5509	H11034L	E-9067A	H8644	E-2363
H10858	E-5510	H11035R	E-9068A	H8645	E-2382
H10858L	E-5510	H12000L	E-10929	H8646	E-2086B
H10859	E-5511	H12001R	E-10930	H8648	E-2125
H10859R	E-5511	H12032L	E-11866	H8649	E-2090

COMPETITOR INTERCHANGE

HERCULES (cont)

COMPETITOR NUMBER	EUCLID NUMBER
H8650	E-2122
H8652	E-2287
H8655	E-2469
H8656	E-2087
H8657	E-2089
H8660	E-2291
H8661	E-2670
H8681	E-2088A
H8682	E-2469
H8683	E-3520A
H8684	E-2696A
H8685Z	E-2680
H8686	E-2679A
H8688	E-3468A
H8696	E-1318A
H8707	E-3993B
H8712	E-2494
H8714	E-2104
H8742	E-5140
H8743	E-3446
H8746	E-5501
H8746Z	E-10897
H8766	E-5513
H8772M	E-9078HD
H8783	E-6076
H8788	E-6078
H8792	E-9790A
H8793	E-9053
HCK1407	E-2090
HCK1410	E-2287
HCK1419	E-3520A
HCK1425	E-3993B
HCK1437	E-9790A
HCK1442HD	E-9079HD
HCK1443	E-6078
HQ10002L	E-2479B
HQ10003R	E-2478B
HQ10004L	E-2701B
HQ10005R	E-2700B
HQ10012L	E-9687A
HQ10013R	E-9688A
HQ10014L	E-1774C
HQ10015R	E-1773C
HQ10016L	E-1148C
HQ10017R	E-1147C
HQ10018L	E-9689A
HQ10019R	E-9690A
HQ10022L	E-4705B
HQ10023R	E-4704B
HQ10024L	E-4707B
HQ10025R	E-4706B
HQ10034L	E-9691A

HERCULES (cont)

COMPETITOR NUMBER	EUCLID NUMBER
HQ10035R	E-9692A
HQ10036L	E-4703B
HQ10037R	E-4702B
HQ10044L	E-4709B
HQ10045R	E-4708B
HQ10260L	E-4711B
HQ10261R	E-4710B
HQ10276L	E-2447A
HQ10277R	E-2448A
HQ10278L	E-4715A
HQ10279R	E-4714A
HQ10284L	E-689A
HQ10285R	E-688A
HQ10300L	E-9645
HQ10301R	E-9646
HQ10302L	E-9649
HQ10303R	E-9650
HQ10304L	E-5504A
HQ10305R	E-5505A
HQ10306L	E-9655
HQ10307R	E-9656
HQ10308L	E-11543
HQ10309R	E-11542
HQ10310L	E-9659
HQ10311R	E-9660
HQ10312L	E-9661
HQ10313R	E-9662
HQ10316L	E-9671
HQ10317R	E-9672
HQ10318L	E-4733A
HQ10318L	E-9673A
HQ10319R	E-4732A
HQ10319R	E-9674A
HQ10320L	E-4733A
HQ10320L	E-9673A
HQ10321R	E-4732A
HQ10321R	E-9674A
HQ10322L	E-9675
HQ10323R	E-9676
HQ10324L	E-9679
HQ10325R	E-9680
HQ10326L	E-11581
HQ10327R	E-11580
HQ10328L	E-9681
HQ10329R	E-9682
HQ10330L	E-10306A
HQ10331R	E-10307A
HQ10332L	E-11585
HQ10333R	E-11584
HQ10334L	E-11603
HQ10335R	E-11602
HQ10336L	E-9677

HERCULES (cont)

COMPETITOR NUMBER	EUCLID NUMBER
HQ10337R	E-9678
HQ10338L	E-11517
HQ10339R	E-11516
HQ10340L	E-9663
HQ10341R	E-9664
HQ10342L	E-9683
HQ10343R	E-9684
HQ10344L	E-9647
HQ10345R	E-9648
HQ10346L	E-9651
HQ10347R	E-9652
HQ10348L	E-9657
HQ10349R	E-9658
HQ10350L	E-5506
HQ10351R	E-5507
HQ10352L	E-5508
HQ10353R	E-5509
HQ10354L	E-5510
HQ10355R	E-5511
HQ10356L	E-9667
HQ10357R	E-9668
HQ10358L	E-9669
HQ10359R	E-9670
HQ10360L	E-9653
HQ10361R	E-9654
HQ10362L	E-9665
HQ10363R	E-9666
HQ10364L	E-2441B
HQ10365R	E-2442B
HQ10366L	E-2443B
HQ10367R	E-2444B
HQ10368L	E-2445B
HQ10369R	E-2446B
HQ10374L	E-11513
HQ10375R	E-11512
HQ10376L	E-11515
HQ10377R	E-11514
HQ10378L	E-11519
HQ10379R	E-11518
HQ10382L	E-11525
HQ10383R	E-11524
HQ10384L	E-11527
HQ10385R	E-11526
HQ10386L	E-11529
HQ10387R	E-11528
HQ10388L	E-11531
HQ10389R	E-11530
HQ10390L	E-11533
HQ10391R	E-11532
HQ10392L	E-11535
HQ10393R	E-11534
HQ10396L	E-11545

COMPETITOR INTERCHANGE

HERCULES (cont)	
COMPETITOR NUMBER	EUCLID NUMBER
HQ10397R	E-11544
HQ10398L	E-11547
HQ10399R	E-11546
HQ10506L	E-1425A
HQ10507R	E-1424A
HQ10522L	E-5520
HQ10523R	E-5521
HQ10532L	E-2449A
HQ10533R	E-2450A
HQ10752L	E-2451A
HQ10753R	E-2452A
HQ10764L	E-2413A
HQ10765R	E-2412A
KIT#1	E-4515QHD-N
KIT#1A	E-4515UHD
KIT#2	E-1887AHD
KIT#2	E-1887ASHD
KIT#2	E-4311EHD-N
KIT#3	E-3710HD
KIT#3	E-4515XHD
HOLLAND HITCH	
COMPETITOR NUMBER	EUCLID NUMBER
1471301	E-8652
16045	E-7451
16049	E-8652
219160X	E-526
330733	E-2177
330733	E-523
330733X	E-2177
330733X	E-523
ACD21935	E-4891
ACD21936	E-4890
ACD2285900	E-1577A
ACF13281	E-3227
ACF30791	E-2767
ACF33781	E-3711
ACF4024900	E-4594
ACF64141	E-3490B
APA09981	E-9761
APA09982	E-9762
AXA0068	E-920
AXA0068X	E-920
AXA0413900	E-1567
AXA0417	E-1565
AXA04171	E-1565
AXA0418	E-1569
AXA04181	E-1569
AXA04201	E-1563
AXA04202	E-1564
AXA04203	E-2099
AXA04204	E-2100

HOLLAND HITCH (cont)	
COMPETITOR NUMBER	EUCLID NUMBER
AXA04205	E-3862
AXA04206	E-3861
GL0303010	E-702A
KP-AAR-880	E-700
KPT809F	E-700
XA16045	E-7451
XA2016	E-9568
XB00112	E-7450
XB00122	E-8927
LELAND	
COMPETITOR NUMBER	EUCLID NUMBER
1010MS	10-10S
1012M	10-12B
107MS	10-7S
108MS	10-8S
109MS	10-9S
208MS	20-8S
209M	20-9B
209MS	20-9S
2370	E-3490S
2918	E-5303A
4-4.5M	4-4.5B
445M	4-4.5B
4515AQHD	E-2769SHD
4515AQHD	E-4515QHD-N
4515AQM	E-6999SHD
74M	7-4B
75M	7-5B
76MS	7-6S
77MS	7-7S
78M	7-8B
810MS	8-10S
86MS	8-6S
87MS	8-7S
88MS	8-8S
89M	8-9B
8X18	E-7044
E3116	E-5511
E9052	E-9052
K104	E-2679A
K105	E-2286
K106	E-2126
K108	E-2090
K109	E-1816SHD
K109	E-4515PHD
K110	E-2820
K112	E-3525
K116	E-1816SHD
K116	E-4515PHD
K117	E-2769S
K117	E-4515Q-N

LELAND (cont)	
COMPETITOR NUMBER	EUCLID NUMBER
K118	E-4880S
K119	E-1887ASHD
K119	E-4311EHD-N
K123	E-2287
K125	E-3895S
K125	E-4515U
K127	E-4880S
K128	E-2769SHD
K128	E-4515QHD-N
K128A	E-6999SHD
K128K	E-2769HD
K128K	E-2769SHD
K128K	E-4515QHD-N
K130	E-2740
K131	E-3353A
K132	E-2713
K133	E-3354
K134	E-3291
K135	E-3710S
K135	E-4515X
K136	E-3710SHD
K136	E-4515XHD
K137	E-3782
K138	E-2089
K139	E-2123
K140	E-2125
K141	E-2696A
K144	E-2469
K144	E-2526
K145	E-2469
K145	E-2469-2
K146	E-2087
K147	E-2494
K148	E-2363
K149	E-2363
K151	E-2680
K152	E-2679A
K154	E-3484
K157	E-2469
K161	E-2088A
K162	E-2679A
K165	E-4078
K23	E-7213A
K23	E-7214A
K235	E-2157
K236	E-2159
K24	E-7213A
K256	E-3520A
K257	E-3520A
K259	E-4800
K26	E-3525
K26(2)	E-3525

COMPETITOR INTERCHANGE

LELAND (cont)

COMPETITOR NUMBER	EUCLID NUMBER
K260	E-1308T
K260	E-4691
K263	E-1308E
K263	E-5139
K264	E-5140
K265	E-6879
K266	E-2121
K268	E-2088A
K268	E-2088AHD
K269	E-3520A
K270	E-3520A
K272	E-3468A
K273	E-3446
K274	E-3518
K275	E-2821
K277	E-3373HD
K278	E-3993B
K279	E-3782
K280	E-3710S
K280	E-4515X
K280A	E-3710S
K280A	E-4515X
K281	E-3992
K282	E-1308Q
K282	E-3869
K282	E-7899
K283	E-1308Q
K283	E-3869
K284	E-2522
K285	E-3876
K286	E-4692
K288	E-3374HD
K289	E-3989AHD
K289	E-9078HD
K289(2)	E-9078HD
K292	E-9644
K293	E-5086
K295	E-4709ES-N
K295	E-5481A
K296	E-5501
K297	E-7231
K299	E-7237
K30	E-1493
K30	E-1495
K30	E-1496
K301	E-7235
K303	E-3895S
K303	E-4515U
K304	E-3895SHD
K304	E-4515UHD
K305	E-5515
K306	E-2769S

LELAND (cont)

COMPETITOR NUMBER	EUCLID NUMBER
K306	E-4515Q-N
K307	E-9048
K308	E-2746
K309	E-8923
K309K	E-3710S
K309K	E-4515X
K309K	E-8923
K31	E-2157
K310	E-9080
K311	E-2746
K312	E-9053
K313	E-9079HD
K314	E-2287
K315	E-3710S
K315	E-4515X
K316	E-3801
K318	E-4702-KT
K318	E-9064
K318K	E-4702-KT
K318K	E-9064
K31Z	E-2157
K32	E-2159
K321	E-6999S
K322	E-8925
K323	E-7214A
K324	E-7213A
K325	E-7212A
K326	E-9142
K328	E-3710S
K328	E-4515X
K329	E-2769SHD
K329	E-4515QHD-N
K330	E-3710S
K330	E-4515X
K330	E-8923
K332	E-2769SHD
K332	E-4515QHD-N
K334	E-9644
K335	E-9281
K336	E-9283
K338	E-9282
K339	E-2769HD
K339	E-2769S
K339	E-4515QHD-N
K340	E-9790A
K343	E-2287
K344	E-2287
K345	E-2469
K346	E-2087
K348	E-2287
K348	E-9790A
K352	E-2402HD

LELAND (cont)

COMPETITOR NUMBER	EUCLID NUMBER
K353	E-10875
K354	E-3710HD
K354	E-4515XHD
K355	E-9790A-2
K356	E-9141
K357	E-2125
K358	E-9039
K359	E-2125
K360	E-2696A
K361	E-9791HD
K362	E-4692
K363	E-9079HD
K366	E-9070
K367	E-3993B
K368	E-2088AHD
K369	E-10875
K373	E-10756
K374	E-11493
K375	E-10244
K375	E-4709ES2-N
K376	E-10760
K42	E-1887ASHD
K42	E-4311EHD-N
K43	E-2121
K45	E-1816SHD
K45	E-4515PHD
K46	E-1607HD
K48	E-2086B
K48(2)	E-2086B
K481	E-11450
K481	E-11450HD
K49	E-2088A
K494	E-11910
K50	E-2403HD
K503	E-11897
K505	E-9790A
K506	E-9791HD
K51	E-1357A
K515	E-11981
K52	E-2122
K52(2)	E-2122
K53	E-2382
K53(2)	E-2382
K60	E-1816S
K60	E-4515P
K61	E-1607HD
K62	E-2030HD
K63	E-7212A
K64	E-2158
K67	E-5542
K69	E-2402HD
K70	E-2769S

COMPETITOR INTERCHANGE

LELAND (cont)		LELAND (cont)		LELAND (cont)	
COMPETITOR NUMBER	EUCLID NUMBER	COMPETITOR NUMBER	EUCLID NUMBER	COMPETITOR NUMBER	EUCLID NUMBER
K70	E-4515Q-N	L1047	E-5532	L1289	E-2241
K70A	E-6999S	L1049	E-5537	L1290	E-5239
K75	E-1816HD	L105	E-1269	L1292	E-2689
K75	E-1816S	L1065	E-1497	L1293	E-2405
K75	E-4515PHD	L1066	E-1486	L1294	E-2407
K76	E-4880S	L1072	E-1788	L1295	E-2406
K77	E-2675HD	L1073	E-1789	L1296	E-2408
K79	E-2089	L1074	E-1410	L1297	E-2411A
K79	E-2123	L1075	E-1411	L1298	E-2442B
K80	E-2125	L109	E-537	L1299	E-2441B
K81	E-2086B	L110	E-563	L1300	E-2281
K82	E-2088A	L111	E-538	L1301	E-2282
K82	E-2088AHD	L112	E-541	L1305	E-2670
K83	E-2696A	L113	E-502	L1307	E-1314
K84	E-2287	L114	E-503	L1308	E-2458HD
K86	E-2089	L115	E-543	L1317	E-2484
K87	E-2469	L116	E-544	L1321	E-2685
K87	E-2526	L1178	E-3994	L1356	E-759
K88	E-2090	L118	E-527	L1368	E-2390
K89	E-2469	L1183	E-5540	L1369	E-2391
K90	E-2087	L1184	E-5540	L137	E-526
K9001	E-1816HD	L1188	E-2484	L1370	E-2392
K9001	E-4515PHD	L1190	E-1580	L1371	E-2409
K91	E-2494	L1191	E-1577A	L1372	E-2404
K93	E-1357A	L1193	E-688	L1373	E-2389
K94	E-2122	L1193	E-688A	L1377	E-2760
K95	E-2363	L1194	E-689	L1380	E-2763
K95	E-2679A	L1194	E-689A	L1383	E-9069
K97	E-2382	L1198	E-2104	L1384	E-2492
K98	E-2679A	L1199	E-2102	L1385	E-2493
K98	E-2679AHD	L120	E-564	L1412	E-2478B
K99	E-2680	L1202	E-1775	L1413	E-2479B
L100	E-500	L1203	E-1776	L1416	E-2766S
L101	E-501	L1204	E-1773C	L1417	E-2767
L1010	E-1214	L1205	E-1774C	L1418	E-2768
L1011	E-1215	L1209	E-1403	L144A	E-583X
L1012	E-2162	L1209	E-2126	L144C	E-635X
L1013	E-2161	L1212	E-1307	L144E	E-797X
L1014	E-1230	L124	E-504	L144F	E-636X
L1015	E-2164	L1275	E-2091	L144G	E-628X
L1017	E-2015	L1278	E-2401	L144H	E-798X
L1019	E-2193	L1279	E-2398	L145	E-773
L1020	E-2522	L128	E-2214	L1475	E-2672
L1020(2)	E-2522	L128	E-505	L1476	E-2444B
L1023	E-2100	L1280	E-2395	L1477	E-2443B
L1024	E-2099	L1281	E-2396	L1478	E-2778
L103	E-10814	L1282	E-2393	L1482	E-3441
L1034	E-1402	L1282	E-2393A	L149	E-523
L1035	E-1400	L1283	E-2394	L1496	E-2773
L1039	E-1457	L1283	E-2394A	L1498	E-1893
L1040	E-5239	L1286	E-1140	L1499	E-5532
L1046	E-3492	L1288	E-2684	L151	E-539

COMPETITOR INTERCHANGE

LELAND (cont)

LELAND (cont)

LELAND (cont)

COMPETITOR NUMBER	EUCLID NUMBER
L152	E-512
L1533	E-2177
L1534	E-2217A
L1535	E-2399
L1536	E-759
L1537	E-3007A
L1539	E-7043
L158	E-586
L1585	E-2390
L1594	E-1385
L1597	E-2690A
L1598	E-2695
L1599	E-2208
L1600	E-1406
L1602	E-2474
L1603	E-2475
L1605	E-1398
L1606	E-3234
L1608	E-1781
L1609	E-1782
L1610	E-9077
L1611	E-2405
L1612	E-1565
L1617	E-2694
L1618	E-2693
L1619	E-2786
L1620	E-2787
L1621	E-2801
L1622	E-2802
L1623	E-2803
L1624	E-2804
L1625	E-2805
L1627	E-2109
L1628	E-2108
L1629	E-2107
L1630	E-2785
L1631	E-2799
L1632	E-2800
L1633	E-3473
L1641	E-2551
L1642	E-2477B
L1643	E-2686
L1644	E-2687
L1645	E-4902
L1646	E-3511
L1648	E-2459HD
L1649	E-1319A
L1650	E-2476
L1651	E-2448A
L1652	E-2447A
L1653	E-2452A
L1654	E-2451A

COMPETITOR NUMBER	EUCLID NUMBER
L1655	E-2450A
L1656	E-2449A
L1657	E-2446B
L1658	E-2445B
L166	E-536
L1662	E-3859
L1669	E-2740
L167	E-535
L1670	E-2723
L1671	E-2724
L1672	E-979
L1673	E-2725
L1674	E-2724
L1674	E-2726
L1675	E-2798
L1676	E-2728
L168	E-579A
L1680	E-2732
L1681	E-2733
L1683	E-1337
L1684	E-2714A
L1685	E-2715A
L1686	E-2716
L1687	E-2717
L1689	E-2712
L1691	E-3421A
L1693	E-2770
L1695	E-1583
L1696	E-1582
L1697	E-1581
L1706	E-2552
L1708	E-2154
L1709	E-2155
L1710	E-2156
L1711	E-2517
L1716	E-2176
L1717	E-2215
L1718	E-2103
L1719	E-1408
L1720	E-4992
L1721	E-4991
L1724	E-3473
L1726	E-654
L1727	E-536
L1728	E-654
L1729	E-1314
L173	E-1424A
L173	E-556
L1730	E-2361
L1732	E-3438
L1733	E-3439
L1734	E-3437

COMPETITOR NUMBER	EUCLID NUMBER
L1736	E-3424
L1737	E-3461
L1738	E-3460
L1739	E-4919
L174	E-1425A
L174	E-557
L1740	E-4918
L1743	E-3471
L1744	E-3469
L1745	E-3474
L1746	E-3447
L1747	E-3476
L1748	E-3475
L1751	E-3427
L1753	E-3472
L1755	E-1106
L1764	E-2164
L1765	E-2163
L1766	E-2380
L1767	E-1271
L1768	E-1272
L1769	E-2745
L1770	E-1416
L1782	E-2101
L1783	E-2111A
L1784	E-2119
L179	E-545A
L1790	E-2307
L182X	E-608
L183	E-530
L1901	E-1901
L1902	E-1902
L1903	E-1903
L1904	E-1904
L1905	E-1905
L1906	E-1906
L1907	E-1907
L1908	E-1908
L1909	E-1909
L1910	E-1910
L1911	E-1911
L1912	E-1912
L1913	E-1913
L1914	E-1914
L1915	E-1915
L1916	E-1916
L1917	E-1917
L1918	E-1918
L1919	E-1919
L192	E-581
L1920	E-1920
L1921	E-1921

COMPETITOR INTERCHANGE

LELAND (cont)		LELAND (cont)		LELAND (cont)	
COMPETITOR NUMBER	EUCLID NUMBER	COMPETITOR NUMBER	EUCLID NUMBER	COMPETITOR NUMBER	EUCLID NUMBER
L1922	E-1922	L2349	E-5498	L2459	E-4705B
L1923	E-1923	L235	E-687	L2464	E-4996
L1924	E-1924	L2351	E-3481A	L2465	E-4995
L1925	E-1925	L2352	E-3483	L2466	E-4720
L1926	E-1926	L2353	E-3482	L2467	E-4721
L1927	E-1927	L2354	E-3304	L2468	E-9744
L1928	E-1928	L2355	E-3303	L2469	E-9743
L1929	E-1929	L2356	E-9090	L2470	E-5097
L193	E-580	L2357	E-9089	L2471	E-5096
L1930	E-1930	L2363	E-3920	L2472	E-9746
L1931	E-1931	L2364	E-3711	L2473	E-9745
L1932	E-1932	L2366	E-5303A	L2476	E-9748
L1933	E-1933	L2367	E-5305	L2477	E-9747
L1934	E-1934	L2368	E-5304	L2480	E-3524
L1935	E-1935	L2369	E-9054	L2481	E-3523
L1936	E-1936	L2370	E-3490B	L2482	E-4889
L1937	E-1937	L2370	E-3490S	L2483	E-4888
L1941	E-1597A	L2379	E-4891	L2484	E-9766
L1942	E-2644	L238	E-609	L2485	E-9765
L1943	E-2644	L2380	E-4890	L2486	E-4887
L1944	E-1362	L2381	E-2656	L2487	E-4886
L1948	E-2654	L2382	E-2690A	L2488	E-9764
L1949	E-2655	L2399	E-2819	L2489	E-9763
L196	E-612HD	L240	E-501	L2493	E-940HD
L202	E-656	L2400	E-2687	L2494	E-4904S
L203	E-602	L2403	E-5057	L250	E-595
L2035	E-1778	L2404	E-5056	L251	E-596A
L2036	E-2668	L242	E-603	L260	E-10812
L2037	E-2669	L2435	E-6075	L261	E-2412
L2047	E-3522	L2438	E-4714	L261	E-2412A
L2048	E-3417	L2438	E-4714A	L261	E-688
L2089	E-2796	L2439	E-4715	L261	E-688A
L2090	E-2797	L2439	E-4715A	L262	E-2413
L2098	E-3228	L2440	E-2794	L262	E-2413A
L2100	E-1308	L2441	E-2795	L262	E-689
L219	E-632	L2442	E-9710	L262	E-689A
L224	E-684	L2443	E-9709	L263	E-633X
L225	E-685	L2446	E-9692A	L264	E-634X
L228	E-3524	L2447	E-9691A	L266	E-661
L229	E-3523	L2448	E-9690A	L2670	E-3713
L2338	E-9662	L2448	E-9690A	L2671	E-3714
L2339	E-9661	L2449	E-9689A	L2707	E-4594
L234	E-686	L2449	E-9689A	L2711	E-4587
L2340	E-9660	L2450	E-4708B	L2712	E-4586
L2340	E-9660	L2451	E-4709B	L2714	E-4593
L2341	E-9659	L2452	E-4702B	L2796	E-7218
L2341	E-9659	L2453	E-4703B	L2797	E-7217
L2342	E-9676	L2454	E-2700B	L2803	E-2729
L2343	E-9675	L2455	E-2701B	L2804	E-2729
L2346	E-3491	L2456	E-4706B	L2805	E-4785
L2347	E-3517	L2457	E-4707B	L2808	E-5126
L2348	E-3516	L2458	E-4707B	L2811	E-3421A

COMPETITOR INTERCHANGE

LELAND (cont)

LELAND (cont)

LELAND (cont)

COMPETITOR NUMBER	EUCLID NUMBER
L2820	E-10864
L2821	E-10863
L2825	E-5122
L2826	E-3421A
L2827	E-5125
L2828	E-5124
L2829	E-5123
L2830	E-5128
L2831	E-5127
L2832	E-5137
L2833	E-5138
L2834	E-5130
L2835	E-5129
L2836	E-5136
L2837	E-5135
L2838	E-5134
L2839	E-5133
L2843	E-9643
L2846	E-4911A
L2847	E-4910A
L2854	E-1318A
L2856	E-1140
L2858	E-3512
L2859	E-3513
L2868	E-9648
L2869	E-9647
L2870	E-9650
L2871	E-9649
L2872	E-9656
L2873	E-9655
L2874	E-9654
L2875	E-9653
L2876	E-9658
L2877	E-9657
L2878	E-9660
L2879	E-9659
L2880	E-9668
L2881	E-9667
L2882	E-9670
L2883	E-9669
L2884	E-9672
L2885	E-9671
L2886	E-4732A
L2887	E-4733A
L2888	E-4732A
L2889	E-4733A
L2890	E-9678
L2891	E-9677
L2897	E-3855
L2898	E-3854
L2900	E-4736
L2902	E-9268

COMPETITOR NUMBER	EUCLID NUMBER
L2903	E-9267
L2904	E-9272
L2905	E-9271
L2908	E-9274
L2909	E-9273
L2910	E-9278
L2911	E-9277
L2912	E-9280
L2913	E-9279
L2914	E-9270
L2915	E-9269
L2916	E-2393A
L2917	E-2394A
L2918	E-5303A
L2919	E-9266
L2920	E-9265
L2926	E-656
L2927	E-3478
L2928	E-3479
L2929	E-5528
L2930	E-3870
L2931	E-3872
L2932	E-3869
L2932	E-3873
L2933	E-3874
L2934	E-3871
L2938	E-3878
L2939	E-3877
L294	E-781
L2940	E-9076
L2941	E-2405
L2942	E-6080
L2943	E-3231
L2944	E-9075
L2945	E-9073
L2947	E-2411A
L2948	E-4885
L2949	E-4884
L2950	E-3823
L2951	E-5092
L2952	E-5087
L2953	E-5088
L2954	E-5089
L2957	E-10828
L296	E-3421A
L2960	E-5477
L2961	E-5478
L2962	E-10197
L2963	E-5482
L2966	E-5495
L2967	E-5494
L2968	E-5497

COMPETITOR NUMBER	EUCLID NUMBER
L2969	E-5496
L297	E-3421A
L2970	E-5491
L2971	E-5490
L2974	E-5493
L2975	E-5492
L2976	E-9770
L2977	E-9769
L2981	E-5480
L2982	E-7230
L2985	E-2805
L299	E-662
L2992	E-7236
L3003	E-6991A
L3004	E-6992A
L3005	E-6993A
L3006	E-6994A
L3007	E-6995A
L3008	E-6996A
L3009	E-6987A
L3010	E-6989A
L3011	E-5503
L3012	E-8922
L3013	E-8924
L3014	E-9025
L3015	E-9026
L3016	E-9027
L3017	E-9040
L3018	E-9043
L3019	E-9044
L3020	E-3920
L3021	E-9045
L3022	E-9046
L3023	E-9041
L3024	E-9047
L3025	E-9042
L3026	E-4722
L3027	E-4723
L3028	E-7211
L3029	E-5512
L303	E-712
L3030	E-5523
L3031	E-5522
L3032	E-9061
L3033	E-6076
L3034	E-9664
L3035	E-9663
L3036	E-4901
L3037	E-4900
L3038	E-9646
L3039	E-9645
L304	E-714

COMPETITOR INTERCHANGE

LELAND (cont)		LELAND (cont)		LELAND (cont)	
COMPETITOR NUMBER	EUCLID NUMBER	COMPETITOR NUMBER	EUCLID NUMBER	COMPETITOR NUMBER	EUCLID NUMBER
L3040	E-4594	L3099	E-9661	L3174	E-9036
L3041	E-9071	L3100	E-9672	L3175	E-9038
L3042	E-6076	L3101	E-9671	L3182	E-3775
L3043	E-6078	L3102	E-4732A	L3183	E-9069
L3044	E-5527	L3102	E-9674A	L3192	E-9033
L3045	E-5526	L3103	E-4733A	L3193	E-9032
L3046	E-9099	L3103	E-9673A	L3194	E-9031
L3047	E-9098	L3104	E-9674A	L3195	E-9030
L3050	E-11562	L3105	E-9673A	L3200	E-9058
L3051	E-11563	L3106	E-9676	L3201	E-9057
L3052	E-5537	L3107	E-9675	L3202	E-9060
L3053	E-5531	L3108	E-9680	L3203	E-9059
L3054	E-5539	L3109	E-9679	L321	E-512
L3055	E-3997	L3110	E-9682	L3224	E-9783
L3056	E-3859	L3111	E-9681	L3225	E-9102
L3057	E-6077	L3112	E-5507	L3228	E-4594
L3058	E-9072	L3113	E-5506	L324	E-747
L3058	E-9074	L3114	E-5509	L3240	E-9097
L3059	E-6988A	L3115	E-5508	L3241	E-9096
L3063	E-9133	L3116	E-5511	L3244	E-9029
L3064	E-9132	L3117	E-5510	L3245	E-9028
L3065	E-6987A	L3118	E-8907	L3246	E-9657
L3065	E-6988A	L3123	E-9135	L3247	E-9658
L3066	E-6989A	L3124	E-9742	L3248	E-9032
L3066	E-6990A	L3125	E-9741	L3249	E-9034
L3067	E-2768	L3126	E-9643	L3249	E-9035
L3068	E-9074	L3127	E-9789	L3254	E-9754
L3069	E-9063	L3130	E-9274	L3255	E-9753
L3070	E-9062	L3131	E-9273	L326	E-795
L3072	E-5525	L3132	E-9270	L3260	E-9756
L3073	E-5524	L3133	E-9269	L3261	E-9755
L3076	E-9768	L3134	E-9278	L3264	E-9758
L3077	E-9767	L3135	E-9277	L3265	E-9757
L3078	E-10912	L3136	E-9268	L3268	E-10902
L3079	E-10911	L3137	E-9267	L3269	E-10901
L3082	E-9708	L3138	E-9272	L327	E-796
L3083	E-9707	L3139	E-9271	L3272	E-10904
L3084	E-5530	L3140	E-9266	L3273	E-10903
L3085	E-5529	L3141	E-9265	L3274	E-10908
L3086	E-9716	L3142	E-9280	L3275	E-10907
L3087	E-9715	L3143	E-9279	L3276	E-10906
L3088	E-9066	L3144	E-9056	L3277	E-10905
L3089	E-9065	L3145	E-9055	L3282	E-9732
L3090	E-5505A	L3146	E-9792A	L3283	E-9731
L3091	E-5504A	L3148	E-2398	L3284	E-11859
L3092	E-9656	L3160	E-9095A	L3285	E-11858
L3093	E-9655	L3161	E-10949A	L3286	E-9734
L3094	E-11540	L3161	E-6993A	L3287	E-9733
L3095	E-11541	L3170	E-9760	L3288	E-9736
L3096	E-9660	L3171	E-9759	L3289	E-9735
L3097	E-9659	L3172	E-9140	L329	E-654
L3098	E-9662	L3173	E-9037	L3290	E-5521

COMPETITOR INTERCHANGE

LELAND (cont)

LELAND (cont)

LELAND (cont)

COMPETITOR NUMBER	EUCLID NUMBER
L3291	E-5520
L3292	E-5517
L3293	E-5516
L3294	E-9772
L3295	E-9771
L330	E-667
L3300	E-10913
L3301	E-10914
L3302	E-9264
L3303	E-9263
L3304	E-9276
L3305	E-9275
L3306	E-9728
L3307	E-9727
L331	E-5093
L3310	E-9101
L3311	E-9100
L3312	E-9714
L3313	E-9713
L3314	E-9762
L3315	E-9761
L3318	E-3862
L3319	E-3861
L3319	E-3862
L3320	E-10910
L3321	E-10909
L3322	E-9696
L3323	E-9695
L3324	E-9702
L3325	E-9701
L3326	E-9698
L3327	E-9697
L333	E-537
L3330	E-9684
L3331	E-9683
L3334	E-9682
L3335	E-9681
L3338	E-9677
L3339	E-9678
L334	E-671
L3340	E-11584
L3341	E-11585
L3342	E-9068A
L3342	E-9067
L3342	E-9067A
L3342	E-9068A
L3343	E-9067A
L3344	E-10307A
L3345	E-10306A
L3346	E-9088
L3347	E-9087
L3348	E-11522

COMPETITOR NUMBER	EUCLID NUMBER
L3349	E-11523
L3350	E-9650
L3351	E-9649
L3352	E-10950A
L3354	E-10876
L3355	E-10877
L3357	E-10878
L3363	E-9071
L3364	E-9077
L3369	E-10198
L3370	E-9038
L3373	E-10761
L3376	E-9730
L3377	E-9729
L3378	E-11861
L3379	E-11860
L3380	E-5519
L3381	E-5518
L3392	E-9740
L3393	E-9739
L3398	E-9652
L3399	E-9651
L3400	E-10916
L3401	E-10915
L3402	E-9670
L3403	E-9671
L3406	E-9738
L3407	E-9737
L3414	E-9657
L3415	E-9658
L3416	E-9654
L3417	E-9653
L3418	E-9666
L3419	E-9665
L3436	E-9648
L3437	E-9647
L344	E-719
L3444	E-11867
L3445	E-11866
L346	E-2087
L3482	E-9668
L3483	E-9667
L3484	E-11446
L3485	E-11445
L3488	E-10924
L3489	E-10923
L3490	E-11532
L3491	E-11533
L3492	E-11551
L3493	E-11550
L3496	E-9764
L3497	E-9763

COMPETITOR NUMBER	EUCLID NUMBER
L3521	E-11880
L3522	E-10784A
L3523	E-11879
L3524	E-11877
L3528	E-10780A
L3529	E-10779A
L3530	E-10786A
L3531	E-10785A
L3533	E-10782A
L3534	E-10781A
L3536	E-10788A
L3537	E-10787A
L3538	E-10783A
L3546	E-10922
L3547	E-10921
L3548	E-10930
L3549	E-10929
L3550	E-10918
L3551	E-10917
L3574	E-9664
L3575	E-9663
L3578	E-9694
L3579	E-9693
L3580	E-9704
L3598	E-6102
L3599	E-6101
L3600	E-10928
L3601	E-10927
L3630	E-11863
L3631	E-11862
L375	E-752
L385	E-757
L386	E-690
L386	E-9090
L387	E-691
L389	E-759
L392	E-2684
L393	E-2241
L395	E-2685
L397	E-801
L402	E-807
L415	E-961
L417	E-1025
L421	E-937
L425	E-1808
L428	E-1304
L429	E-1305
L430	E-10838
L438	E-1108
L440	E-947
L441	E-864
L443	E-959

COMPETITOR INTERCHANGE

LELAND (cont)	
COMPETITOR NUMBER	EUCLID NUMBER
L445	E-1813
L455	E-1106
L464	E-979
L465	E-980
L467	E-910
L507	E-1147C
L508	E-1148C
L509	E-1107
L512A	E-583X
L512A	E-911X
L512C	E-635X
L512C	E-912X
L512E	E-797X
L512E	E-915X
L512F	E-636X
L512F	E-913X
L512G	E-628X
L512G	E-914X
L512H	E-798X
L512H	E-916X
L513	E-998X
L514	E-917X
L515	E-999X
L516	E-918X
L517	E-957
L556	E-3775
L556	E-886
L562	E-612HD
L566	E-10836
L573	E-10818
L574	E-10826
L579	E-1140
L580	E-1094
L581	E-1095
L594	E-920
L595	E-919
L599	E-759
L728	E-2029
L733	E-1422
L734	E-1423
L735	E-1420
L736	E-1421
L738	E-3775
L738	E-886
L752	E-943
L754	E-3424
L755	E-5541
L756	E-2522
L760	E-3995
L762	E-3997
L764	E-1128
L773	E-1261

LELAND (cont)	
COMPETITOR NUMBER	EUCLID NUMBER
L781	E-1136
L782	E-1137
L784	E-1777
L785	E-1778
L787	E-1139
L788	E-1112A
L811	E-937
L827	E-1880B
L835	E-1428A
L838	E-1563
L839	E-1564
L841	E-1574HD
L845	E-940HD
L888	E-1893
L888	E-1893S
L889	E-1113
L891	E-2291
L894	E-3227
L895	E-1565
L896	E-1567
L897	E-1569
L898	E-1571
L900	E-1394
L901	E-1393
L902	E-4716
L903	E-4717
L913	E-1318A
L964	E-1489
L966	E-1416A
L967	E-1418
L968	E-1458
L970	E-1218
L971	E-1216
L972	E-1217
L975	E-2153
L985	E-1261
SA1218	E-937
SA1257	E-1307
SA1464	E-3975
SA1818	E-1107
SA2705	E-2130
SA2706	E-1600
SB1702	E-3523
SB2490	E-9704
SB2490	E-9704
W451	E-563
W498	E-6000A
W538	E-6000A
W697	20416062003
WT3	E-5833
WT4	E-5834
WT5	E-5205

LELAND (cont)	
COMPETITOR NUMBER	EUCLID NUMBER
WT6	E-5208
WT7	E-5207
WT8	E-5206
MERITOR	
COMPETITOR NUMBER	EUCLID NUMBER
08-008411	E-6000A
1107D56	E-3475
1125P640	E-2361
1199A3719	E-2672
1199A3719	E-3914
1199A625	E-2111A
1199A625	E-2176
1199A625	E-500
1199B626	E-773
1199G3725	E-3421A
1199J3910	E-505
1199K3911	E-504
1199M637	E-2214
1199M637	E-505
1199U3765	E-3511
1199Z910	E-504
1205B2004	E-3995
1205C2005	E-3994
1205G761	E-3859
1205K193	E-563
1205M1105	E-1416
1205N430	E-603
1205N924	E-1272
1205Q2123	E-2405
1205U1451	E-2405
1205V1452	E-2406
1205V1556	E-654
1205X726	E-1314
1218C107	E-3513
1218G85	E-747
1218L90	E-538
1218M43	E-538
1218Z52	E-10834
1225A443	E-920
1225A781	E-2380
1225A833	E-2407
1225B496	E-1893
1225B496	E-8938
1225B834	E-2408
1225C939	E-3474
1225F266	E-2218
1225F266	E-541
1225G449	E-919
1225G631	E-2380
1225J218	E-662
1225J634	E-1271

COMPETITOR INTERCHANGE

MERITOR (cont)		MERITOR (cont)		MERITOR (cont)	
COMPETITOR NUMBER	EUCLID NUMBER	COMPETITOR NUMBER	EUCLID NUMBER	COMPETITOR NUMBER	EUCLID NUMBER
1225L1208	E-536	1229S435	E-10857	1718D134	E-2522
1225L1208	E-5512	1229S747	E-10843	1718D134	E-3869
1225M897	E-3447	1229T1164	E-10851	1718Y103	E-539
1225N1158	E-6080	1229T1554	E-10842	1718Y103	E-5478
1225N378	E-536	1229T3166	E-527	1725H8	E-10839
1225P640	E-2361	1229T4102	E-9077	1725V22	E-10813
1225R1058	E-2361	1229V1504	E-3869	1727N40	E-1128
1225R1136	E-3877	1229V1504	E-3874	1746U47	E-10811
1225R512	E-667	1229V1556	E-3427	1759M13	E-512
1225S1267	E-920	1229X1116	E-801	1759Z26	E-3445
1225U151	E-712	1229X2260	E-9071	1779B1172	E-523
1225U827	E-920	1229X2936	E-10845	1779C81	E-2215
1225U827	E-920S	1229X3118	E-2411A	1779C81	E-781
1225X336	E-667	1229Z1118	E-526	1779D82	E-586
1225X440	E-10836	1245E161	E-10829	1779J1024	E-3859
1225X804	E-2551	1245E164	E-10829	1779J114	E-10812
1229A1119	E-1569	1245N144	E-10819	1779K63	E-3421A
1229A4135	E-9073	1246C627	E-3482	1779L116	E-10838
1229B1848	E-1113	1246F1020	E-3482	1779Q433	E-1262
1229B236	E-3471	1246G475	E-501	1779R18	E-2177
1229B4136	E-9074	1246L350	E-10828	1779R18	E-523
1229C4137	E-9075	1246R382	E-10822	1779U593	E-10824
1229D108	E-10817	1246S227	E-501	1779X180	E-10823
1229D2942	E-5093	1259B262	E-3424	1829P198	E-2724
1229D3124	E-1569	1259G163	E-503	2120X6732	E-10864
1229E1565	E-10831	1259J218	E-1112A	2205P1004	E-3869
1229E811	E-3473	1259K219	E-2119	2205P1004	E-3871
1229E837	E-656	1259L194	E-10835	2210A4265	E-9687A
1229F1566	E-10832	1259L90	E-502	2210A5357S	E-4708B
1229F1618	E-3477	1259N1132	E-2119	2210A5721	E-4707B
1229F2502	E-2411A	1259N1132	E-502	2210A6007	E-4715
1229-F-4686	E-9071	1259N170	E-609	2210A6319	E-685
1229G1099	E-5091	1259P1134	E-512	2210A6319S	E-685
1229G1463	E-656	1259P198	E-10825	2210A6345	E-4884
1229G1567	E-10833	1259Q251	E-512	2210A6943	E-9661
1229G2971	E-1113	1259Q251	E-512S	2210A6995	E-9671
1229H866	E-526	1259R200	E-1112A	2210A7099	E-9659
1229J3130	E-5095	1259R252	E-502	2210A7515	E-9657
1229J4092	E-9076	1259R252	E-503	2210A7619	E-11571
1229J868	E-564	1259R252BK	E-502	2210A7645	E-9677
1229M1105	E-527	1259R252BULK	E-502	2210A7671	E-9681
1229M221	E-1106	1259S201	E-2119	2210A7697	E-11587
1229N2250	E-3478	1259T280	E-512	2210A7749	E-11599
1229P302	E-3472	1259U281	E-502	2210A8217	E-11536
1229Q277	E-3476	1259U281	E-503	2210B5358	E-4709B
1229Q2851	E-4736	1259V308	E-5087	2210B5722	E-4705B
1229Q433	E-1113	1259W205	E-10820	2210B6008	E-4714
1229Q771	E-581	1259X1012	E-3869	2210B6866	E-5507
1229R122	E-580	1259X1012	E-3870	2210B6866B40	E-5507
1229R4100	E-6077	1259X76	E-10814	2210B6866S	E-5507
1229S2697	E-3479	1299G1099	E-5091	2210B7412	E-11516
1229S4101	E-9072	1705M143	E-654	2210B7464	E-11528

COMPETITOR INTERCHANGE

MERITOR (cont)		MERITOR (cont)		MERITOR (cont)	
COMPETITOR NUMBER	EUCLID NUMBER	COMPETITOR NUMBER	EUCLID NUMBER	COMPETITOR NUMBER	EUCLID NUMBER
2210B7542	E-9664	2210E5543S	E-5056	2210G6189	E-4900
2210B7568	E-9668	2210E5673	E-4936	2210G6845	E-3461
2210B7594	E-9672	2210E5673S	E-4936	2210G6845	E-9696
2210BC6867	E-5506	2210E5725	E-2714A	2210G6871	E-5508
2210C5359S	E-1147C	2210E5725S	E-2714A	2210G7417	E-11519
2210C5619	E-4918	2210E5803	E-4995	2210G7443	E-9651
2210C5619S	E-4918	2210E5803S	E-4995	2210G7469	E-11531
2210C6035	E-9660	2210E6167	E-9087	2210G7547	E-11553
2210C6035S	E-9660	2210E6531	E-5529	2210H2946	E-9090
2210C6165	E-3516	2210E6531	E-5530	2210H5338	E-9647
2210C6399	E-4716	2210E6739	E-9715	2210H5416	E-9663
2210C6399S	E-4716	2210E6739S	E-9715	2210H5546	E-9687A
2210C6737	E-5529	2210E6843	E-4913	2210H5546	E-9687A
2210C6737S	E-5529	2210E6843	E-9694	2210H5728	E-4994
2210C6867	E-5506	2210E6869	E-5510	2210H5728S	E-4994
2210C6867B40	E-5506	2210E7493	E-9655	2210H6014	E-4900
2210C6867S	E-5506	2210E7597	E-11567	2210H6170	E-4901
2210C7413	E-11517	2210E7649	E-11575	2210H6482	E-9713
2210C7465	E-11529	2210E7675	E-11583	2210H6820	E-5505A
2210C7543	E-9663	2210E7701	E-11589	2210H6976	E-9065
2210C7569	E-9667	2210E7727	E-11595	2210H7418	E-11520
2210C7595	E-9671	2210E8403	E-11644	2210H7496	E-11538
2210C7959	E-11959	2210F3594	E-556	2210H7522	E-9660
2210C8219	E-11638	2210F4790	E-4913	2210H7522	E-9660
2210D1434	E-688	2210F5414B30	E-1425A	2210H7626	E-9676
2210D1434	E-688A	2210F5544	E-5057	2210H7652	E-9680
2210D5360S	E-1148C	2210F5674	E-4937	2210H7730	E-11596
2210D5620	E-4919	2210F5674S	E-4937	2210H7782	E-11602
2210D5620S	E-4919	2210F5726	E-2715A	2210J2558	E-2412
2210D6036S	E-9659	2210F5726S	E-2715A	2210J2948	E-691
2210D6166	E-3517	2210F5804	E-4996	2210J2948	E-9089
2210D6400	E-4717	2210F5804S	E-4996	2210J3104	E-9690A
2210D6400S	E-4717	2210F6068	E-9088	2210J6484	E-9714
2210D6530	E-5529	2210F6168	E-9088	2210J6614	E-9707
2210D6738	E-5530	2210F6740	E-9716	2210J6822	E-5504A
2210D6738S	E-5529	2210F6740S	E-9716	2210J6978	E-9066
2210D6738S	E-5530	2210F6844	E-3460	2210J7420	E-11521
2210D6842	E-4912	2210F6844	E-9695	2210J7498	E-11539
2210D6842	E-9693	2210F6870	E-5509	2210J7524	E-9659
2210D6868	E-5511	2210F7416	E-11518	2210J7524	E-9659
2210D7492	E-9656	2210F7442	E-9652	2210J7628	E-9675
2210D7596	E-11566	2210F7468	E-11530	2210J7654	E-9679
2210D7648	E-11574	2210F7546	E-11552	2210J7732	E-11597
2210D7674	E-11582	2210F8404	E-11645	2210J7784	E-11603
2210D7700	E-11588	2210G3595	E-557	2210K2559	E-2413
2210D7726	E-11594	2210G4791	E-4912	2210K3105	E-9689A
2210D8220	E-11639	2210G5545	E-9688	2210K5393	E-9684
2210E1435	E-689	2210G5545	E-9688A	2210K5445	E-9678
2210E1435	E-689A	2210G5727	E-4993	2210K5549	E-9692A
2210E5413B30	E-1424A	2210G5727S	E-4993	2210K5549	E-9692A
2210E5439S	E-9650	2210G6013	E-4901	2210K6615	E-9708
2210E5543	E-5056	2210G6169	E-4900	2210K7005	E-9684

COMPETITOR INTERCHANGE

MERITOR (cont)		MERITOR (cont)		MERITOR (cont)	
COMPETITOR NUMBER	EUCLID NUMBER	COMPETITOR NUMBER	EUCLID NUMBER	COMPETITOR NUMBER	EUCLID NUMBER
2210K7343	E-11512	2210N7190	E-9679	2210R5556	E-3461
2210K7395	E-9646	2210N7450	E-9066	2210R5556S	E-3461
2210K7473	E-11532	2210N7502	E-11543	2210R5608S	E-9704
2210K7499	E-11540	2210N7684	E-10306A	2210R5712	E-4715
2210K7551	E-9666	2210N7788	E-11605	2210R6492	E-9715
2210K7603	E-4732A	2210P2564	E-4714	2210R6518	E-9712
2210K7837	E-4732A	2210P5840	E-9645	2210R6726	E-9714
2210K7837	E-9674A	2210P6412	E-1425A	2210R6752	E-9718
2210L5446S	E-9677	2210P6412	E-557	2210R6856	E-9699
2210L5550	E-9691A	2210P6542	E-9717	2210R7428	E-11522
2210L5550	E-9691A	2210P6958	E-9656	2210R7454	E-9068A
2210L5836	E-4911A	2210P6984	E-9676	2210R7454	E-9067
2210L6746	E-9711	2210P7374	E-11514	2210R7454	E-9067A
2210L7006	E-9683	2210P7426	E-9650	2210R7636	E-11572
2210L7266	E-11561	2210P7452	E-11526	2210R7688	E-9684
2210L7344	E-11513	2210P7478	E-11534	2210R7714	E-11590
2210L7396	E-9645	2210P7530	E-11548	2210R7766	E-11600
2210L7474	E-11533	2210P7582	E-11562	2210R7844	E-11558
2210L7500	E-11541	2210P7608	E-11568	2210R8156	E-2441B
2210L7552	E-9665	2210P7660	E-11576	2210R8182	E-11969
2210L7604	E-4733A	2210P7842	E-11544	2210S2489	E-687
2210L7838	E-4733A	2210P8284	E-11635	2210S4465	E-9692A
2210L7838	E-9673A	2210Q4905	E-10863	2210S4907	E-10859
2210L8176	E-11640	2210Q5399	E-4912	2210S5375	E-2700B
2210L8332	E-11628	2210Q5399S	E-4912	2210S5453	E-4911A
2210M1573	E-688	2210Q5555	E-3460	2210S5453S	E-4911A
2210M1573	E-688A	2210Q5555S	E-3460	2210S5973	E-3460
2210M2483	E-1424A	2210Q5607S	E-9703	2210S6493	E-9716
2210M2483	E-556	2210Q5711	E-4714	2210S6727	E-10895
2210M4329B40	E-2441B	2210Q5711S	E-4714	2210S6857	E-9700
2210M5343	E-9678	2210Q6517	E-9711	2210S7429	E-11523
2210M5837	E-4910A	2210Q6543	E-9718	2210S7455	E-9068A
2210M6747	E-9712	2210Q6725	E-9713	2210S7455	E-9067
2210M6851	E-9697	2210Q6751	E-9717	2210S7455	E-9068A
2210M7189	E-9680	2210Q6985	E-9675	2210S7637	E-11573
2210M7449	E-9065	2210Q7375	E-11515	2210S7689	E-9683
2210M7501	E-11542	2210Q7427	E-9649	2210S7715	E-11591
2210M7683	E-10307A	2210Q7453	E-11527	2210S7767	E-11601
2210M7787	E-11604	2210Q7479	E-11535	2210S7845	E-11559
2210M8177	E-11641	2210Q7531	E-11549	2210S8157	E-2444B
2210M8333	E-11629	2210Q7583	E-11563	2210S8183	E-11610
2210N1574	E-689	2210Q7609	E-11569	2210S8287	E-11624
2210N1574	E-689A	2210Q7661	E-11577	2210T2490	E-684
2210N2484	E-1425A	2210Q7843	E-11545	2210T4466	E-9691A
2210N2484	E-557	2210Q8155	E-2442B	2210T4908	E-10860
2210N2562	E-4715	2210Q8155B40	E-2442B	2210T5246	E-3516
2210N5838	E-9646	2210Q8181	E-11968	2210T5376	E-2701B
2210N6410	E-1424A	2210Q9659	E-9655	2210T5454	E-4910A
2210N6410	E-556	2210R2488	E-686	2210T5454S	E-4910A
2210N6592	E-5509	2210R4906	E-10864	2210T5974	E-3461
2210N6852	E-4917	2210R5400	E-4913	2210T6728	E-10896
2210N6852	E-9698	2210R5400S	E-4913	2210T6962	E-9674A

COMPETITOR INTERCHANGE

MERITOR (cont)		MERITOR (cont)		MERITOR (cont)	
COMPETITOR NUMBER	EUCLID NUMBER	COMPETITOR NUMBER	EUCLID NUMBER	COMPETITOR NUMBER	EUCLID NUMBER
2210T7430	E-11524	2210V8316	E-11623	2210Y5719S	E-4703B
2210T7456	E-9654	2210V8342	E-11633	2210Y5953	E-4917
2210T7482	E-5505A	2210V8394	E-11627	2210Y6317	E-687
2210T7534	E-11550	2210W2805	E-1090	2210Y6863	E-9704
2210T7560	E-11554	2210W5353	E-1773C	2210Y6863	E-9704
2210T7586	E-9670	2210W5379	E-9690A	2210Y7071	E-9681
2210T7586	E-9684	2210W5379	E-9690A	2210Y7227	E-9659
2210T7664	E-11578	2210W5405	E-1090	2210Y7409	E-9647
2210T8158	E-2443B	2210W5405S	E-1090	2210Y7565	E-11557
2210T8184	E-11611	2210W5535	E-10861	2210Y7591	E-11565
2210T8288	E-11625	2210W5535S	E-10861	2210Y8085	E-2412A
2210U2491	E-685	2210W5639S	E-2478B	2210Y8215	E-11618
2210U4909	E-10864	2210W5665	E-4997	2210Y8345	E-11612
2210U4909	E-10895	2210W5665S	E-4997	2210Z2340	E-557
2210U5247	E-3517	2210W5717S	E-4706B	2210Z4264	E-9688
2210U5325	E-9660	2210W6731	E-10863	2210Z4992	E-3461
2210U5325S	E-9660	2210W6731	E-9707	2210Z5382S	E-2701B
2210U5533	E-2412	2210W6861	E-4937	2210Z5668	E-4992
2210U5611S	E-4916	2210W6861	E-9702	2210Z5668S	E-4992
2210U5637	E-4710B	2210W7511	E-11547	2210Z5720	E-4702B
2210U6573	E-5507	2210W7537	E-9661	2210Z6318	E-684
2210U6963	E-9673A	2210W7537B40	E-9661	2210Z6318S	E-684
2210U7431	E-11525	2210W7615	E-4910A	2210Z6344	E-4885
2210U7457	E-9653	2210W7667	E-11581	2210Z6942	E-9662
2210U7483	E-5504A	2210W7693	E-11585	2210Z6994	E-9672
2210U7485	E-11537	2210W7719	E-11593	2210Z7098	E-9660
2210U7535	E-11551	2210W8265	E-11630	2210Z7514	E-9658
2210U7561	E-11555	2210W8317	E-11608	2210Z7618	E-11570
2210U7587	E-9669	2210W8395	E-11642	2210Z7644	E-9678
2210U7665	E-11579	2210X5354	E-1774C	2210Z7670	E-9682
2210U8159	E-2446B	2210X5380	E-9689A	2210Z7696	E-11585
2210U8315	E-11622	2210X5380	E-9689A	2210Z7696	E-11586
2210U8341	E-11632	2210X5406	E-1089	2210Z7748	E-11598
2210U8393	E-11626	2210X5406S	E-1089	2210Z8086	E-2413A
2210V2804	E-1089	2210X5536	E-10862	2210Z8216	E-11619
2210V4910	E-10896	2210X5536S	E-10862	2210Z8346	E-11613
2210V5326	E-9659	2210X5718S	E-4707B	2247X128	E-5089
2210V5326S	E-9659	2210X5952	E-4916	2257M1001	E-2522
2210V5534	E-2413	2210X6316	E-686	2258B704	E-3481A
2210V5612S	E-4917	2210X6732	E-9708	2258E1123	E-3869
2210V6860	E-4936	2210X6862	E-9703	2258E1123	E-3873
2210V6860	E-9701	2210X7070	E-9682	2258E499	E-10849
2210V7484	E-11536	2210X7226	E-9660	2258E629	E-1140
2210V7510	E-11546	2210X7408	E-9648	2258G579	E-3437
2210V7536	E-9662	2210X7564	E-11556	2258H1126	E-3869
2210V7536B40	E-9662	2210X7590	E-11564	2258J1440	E-10818
2210V7536F	E-9662	2210X8266	E-11631	2258J400	E-10826
2210V7614	E-4911A	2210X8318	E-11609	2258K1181	E-3872
2210V7666	E-11580	2210X8396	E-11643	2258K349	E-543
2210V7692	E-11584	2210Y2339	E-556	2258K401	E-10818
2210V7718	E-11592	2210Y5667	E-4991	2258L1234	E-9063
2210V8160	E-2445B	2210Y5667S	E-4991	2258P354	E-545A

COMPETITOR INTERCHANGE

MERITOR (cont)		MERITOR (cont)		MERITOR (cont)	
COMPETITOR NUMBER	EUCLID NUMBER	COMPETITOR NUMBER	EUCLID NUMBER	COMPETITOR NUMBER	EUCLID NUMBER
2258Q615	E-2767	3236A1249	E-3775	A13275U593	E-6940
2258R349	E-543	3236A1249	E-886	A13275U593S	E-6924B
2258R590	E-3512	3236B1250	E-3775	A13275U593S	E-6940
2258S1033	E-7211	3236B1250	E-886	A13275V594	E-6923B
2258S643	E-9069	3256L12	E-1928	A13275V594	E-6936
2258T124	E-3481A	3256N1028	E-1919	A13275V594S	E-6923B
2258U619	E-2768	3256Q131	E-1914	A13275V594S	E-6936
2258U619	E-3490B	3264E1279	E-11934	A13275W595	E-6924B
2258V256	E-2398	3264R1292	E-11935	A13275W595	E-6940
2258V256	E-757	3280Y8189	E-5531	A13275W595S	E-6924B
2258W803	E-3490B	3288T5844	E-2477B	A13275W595S	E-6940
2258X804	E-5088	3299B3824	E-2477B	A13275Z598	E-6923B
2258Y1273	E-9643	3299C4189	E-2193	A13275Z598	E-6936
2258Z416	E-1880B	3299H3102	E-1319A	A13275Z598S	E-6923B
2297A5123	E-2135	3299U1061	E-2477B	A13275Z598S	E-6936
2297A5331	E-2137	3736M793	E-2735A	A1-3722J686	E-10809
2297B418	E-1136	3736N326	E-2735A	A1-3722R824	E-10810
2297B5332	E-2136	5X180	E-537	A1705K219	E-3995
2297C2863	E-5537	5X640	E-537	A1705M221	E-5532
2297C419	E-1137	A11705K219	E-3994	A1705W127	E-5532
2297C5021	E-3483	A1199D2526	E-1318A	A1779M195	E-5541
2297C5333	E-2139	A1205D2110	E-3878	A1779W283	E-2015
2297D2370	E-2484	A1205F136	E-10848	A213222G2165	E-9062
2297D2864	E-5538	A1205P1602	E-3469	A213222M2223	E-9062
2297E3983	E-3483	A1205S1943	E-1269	A21705M221	E-5532
2297N2874	E-3499	A1205V1556	E-654	A2-2297-U-4597	E-5539
2297T5350	E-2138	A1225D420	E-943	A2247C1017	E-2140
2297T7222	E-11741	A1225V438	E-943	A2247D1018	E-1261
2297U4571	E-2015	A12297M6461	E-11432	A2247E1019	E-2141
2297V246	E-2819	A1-3105Q1213	E-11952	A2247F1020	E-2142
2297W5327	E-2135	A13222B1952	E-4902	A2297B5670	E-5540
2297X5328	E-2134	A13236A1249	E-3775	A-2297-K-1051	E-9321
2297Y5329	E-1137	A13236A1249	E-886	A2297L3158	E-2484
2297Z5330	E-1136	A13236C1823	E-11943	A2297V2882	E-3492
2758Q43	E-1458	A13236Q2123	E-11940	A23264P1082	E-11937
2758W127	E-2476	A13264J114	E-11941	A23275A599	E-6927B
2760J10	E-1735	A13275A599	E-6924B	A23275A599	E-6944
2760U21	E-1735	A13275A599	E-6940	A23275A599S	E-6927B
2797B418	E-1136	A13275A599S	E-6924B	A23275A599S	E-6944
2797C133	E-5537	A13275A599S	E-6940	A23275B600	E-6925B
2797C419	E-1137	A13275B600	E-6923B	A23275B600	E-6942
2797D134	E-5538	A13275B600	E-6936	A23275B600S	E-6925B
2797F422	E-2136	A13275B600S	E-6923B	A23275B600S	E-6942
2797G423	E-2137	A13275B600S	E-6936	A23275C601	E-6927B
2797H424	E-2138	A13275C601	E-6924B	A23275C601	E-6940
2797J426	E-2139	A13275C601	E-6940	A23275C601S	E-6927B
2797X414	E-2134	A13275C601S	E-6924B	A23275C601S	E-6940
2797Y415	E-2135	A13275C601S	E-6940	A23275T592	E-6925B
3105B210	E-3007A	A13275T592	E-6923B	A23275T592	E-6944
3105L194	E-3007A	A13275T592	E-6936	A23275T592S	E-6925B
3105R200	E-3007A	A13275T592S	E-6923B	A23275U593	E-6927B
3222S71	E-2685	A13275U593	E-6924B	A23275U593	E-6944

COMPETITOR INTERCHANGE

MERITOR (cont)		MERITOR (cont)		MERITOR (cont)	
COMPETITOR NUMBER	EUCLID NUMBER	COMPETITOR NUMBER	EUCLID NUMBER	COMPETITOR NUMBER	EUCLID NUMBER
A23275U593S	E-6927B	A3222P978	E-2241	KIT1105B	E-7214A
A23275U593S	E-6944	A3222Q1837	E-5528	KIT1106B	E-7212A
A23275V59	E-6942	A3222R876	E-2241	KIT1125	E-6879
A23275V594	E-6925B	A3222S1293	E-2778	KIT1129	E-3525
A23275V594S	E-6925B	A3222S1527	E-3491	KIT1164	E-7212A
A23275V594S	E-6942	A3222S1735	E-5092	KIT1191	E-5543
A23275W595	E-6927B	A3222S2021	E-1139	KIT1759	E-1319A
A23275W595	E-6944	A3222T1346	E-3522	KIT6003	E-10870
A23275W595S	E-6927B	A3222V1088	E-3495	KIT8000	E-2769HD
A23275W595S	E-6944	A3222V1348	E-9780	KIT8000	E-2769S
A23275X596	E-2459S-BK	A3222X1142	E-2684	KIT8000A	E-2769S
A23275X596	E-2459HD	A3222Z2288	E-10854	KIT8000BK	E-2769HD
A23275Z598	E-6925B	A3264C1381	E-11936	KIT8000BK	E-2769S
A23275Z598	E-6942	A3264S227	E-11938	KIT8000BULK	E-2769HD
A23275Z598S	E-6942	A3275J686	E-5498	KIT8000HD	E-2769HD
A2375W595	E-6927B	A3275X596	E-2458S-BK	KIT8000HD	E-2769SHD
A24-3722P406	E-10805	A3275X596	E-2458HD	KIT8000HDBK	E-2769HD
A253222V1244	E-4902	A3280U8185	E-3996	KIT8000HDBK	E-2769SHD
A2747G111	E-2140	A3280V8186	E-3997	KIT8000HDBULK	E-2769HD
A2747H112	E-1261	A3280W8187	E-3998	KIT8000MB	E-6999S
A2747J114	E-2141	A3280X8188	E-3999	KIT8000MBA	E-6999S
A2747K115	E-2142	A3299G1541	E-535	KIT8000MBBK	E-6999S
A293275Z1144S	E-6924B	A3299T5844	E-2477B	KIT8000MBBULK	E-6999S
A293275Z1144S	E-6940	A33275E1149S	E-6924B	KIT8000MBHD	E-6999SHD
A3105D1148	E-9784	A33275E1149S	E-6940	KIT8000MBHDBK	E-6999SHD
A3105K219	E-9783	A333F2346	20416062003	KIT8004	E-3484
A3105L1078	E-6076	A333F3022	20416062003	KIT8014	E-3895S
A3105V282	E-1318A	A3722B80	E-2686	KIT8014HD	E-3895SHD
A313722D368	E-10804	A3722D82	E-2687	KIT8022	E-3876
A31705M221	E-5532	A3722E681	E-1457	KIT8023	E-536
A3211A833	E-957	A3722K167	E-3441	KIT8023	E-654
A3222A1717	E-2685	A3722L64	E-2684	KIT8026HD	E-5086
A3222A2159	E-11456	A3722N66	E-2241	KIT8029	E-3869
A3222C1381	E-3304	A3722S71	E-2685	KIT8033	E-5513
A3222D1356	E-3417	A3722T254	E-5239	KIT8033A	E-5513
A3222D2006	E-5503	A3722T358	E-2689	KIT8037	E-9070
A3222D2110	E-11453	A3722U385	E-3441	KIT8042	E-3993B
A3222E1383	E-3303	A3722V360	E-1139	KIT8043	E-2086B
A3222E2111	E-11454	A3736W907	E-11939	KIT8046	E-2088A
A3222F1072	E-3439	A4-3222M1157	E-10803	KIT8046	E-2088AHD
A3222F1982	E-5528	A43264T228	E-11942	KIT8048	E-3520A
A3222F2112	E-11455	A43275X596	E-2458S-BK	KIT8048	E-3989AHD
A-3222-G-1541	E-3304	A43275X596	E-2458HD	KIT8058	E-9078HD
A3222J1440	E-3823	A463275Z1144S	E-6927B	KIT8078	E-9079HD-2
A3222J1570	E-3522	A463275Z1144S	E-6944	KIT8078A	E-9078HD
A3222J2272	E-10850	A63275B1146S	E-6923B	KIT8078A	E-9079
A3222K1103	E-3438	A63275B1146S	E-6936	KIT8078A	E-9079HD
A3222K2169	E-10844	A63275C1147S	E-6923B	KIT8081	E-9644
A3222L1572	E-5239	A63275C1147S	E-6936	KIT8087	E-10243
A3222M2223	E-9062	A693275G501	E-940S-BK	KIT8092	E-3876
A3222N1496	E-6075	A913222S1293	E-2778	KIT8289	E-6078
A3222P2200	E-10847	KIT1105B	E-7213A	KIT8314	E-6078

COMPETITOR INTERCHANGE

MERITOR (cont)

COMPETITOR NUMBER	EUCLID NUMBER
KIT8821	E-5513
KIT8824HD	E-9064
KIT8883	E-11904
KIT9000	E-1816HD
KIT9000	E-1816S
KIT9001	E-1816HD
KIT9001	E-1816SHD
KIT9003	E-2675HD
KIT9004	E-1607HD
KIT9006LHB	E-7213A
KIT9006RHB	E-7214A
KIT9020	E-2522
KIT9033	E-943
KIT9034	E-2670
KIT9035	E-2679A
KIT9035	E-2679AHD
KIT9036	E-2291
KIT9037	E-1357A
KIT9078	E-2086B
KIT9094	E-4691
KIT9094A	E-6879
KIT9179	E-3518
KIT9300	E-3446
KIT9304	E-3468A
KIT9406	E-2675HD
KIT9408	E-3992
KIT9409	E-1607HD
KIT9424	E-4692
KIT9425	E-4800
KIT969	E-2363
KIT970	E-2282
KIT970	E-2382
KIT971	E-2679A
MKT1308E	E-1308E
MKT1308Q	E-1308Q
MKT1308T	E-1308T
MKT4515P	E-4515P
MKT4515PHD	E-4515PHD
MKT4515U	E-4515U
MKT4515UHD	E-4515UHD
MKT4515X	E-4515X
MKT4515XHD	E-4515XHD
MPS2003	E-1735
MPS2003	E-2290
MPS2663	E-2119
N14	E-2522
N15	E-2522
R000943	E-943
R0010931	E-10931
R0010932	E-10932
R0010933	E-10933
R0010934	E-10934

MERITOR (cont)

COMPETITOR NUMBER	EUCLID NUMBER
R0010936	E-10936
R0010937	E-10937
R0010939	E-10939
R0010940	E-10940
R0010942	E-10942
R0010943	E-10943
R0010944	E-10944
R0010945	E-10945
R0010946	E-10946
R0010947	E-10947
R0011003	E-11003
R0011051	E-11051
R001108	E-1108
R0011445	E-11445
R0011446	E-11446
R001250	E-1250
R001362	E-1362
R001597A	E-1597A
R001901	E-1901
R001902	E-1902
R001904	E-1904
R001905	E-1905
R001906	E-1906
R001907	E-1907
R001908	E-1908
R001909	E-1909
R001910	E-1910
R001911	E-1911
R001912	E-1912
R001913	E-1913
R001914	E-1914
R001915	E-1915
R001916	E-1916
R001917	E-1917
R001918	E-1918
R001919	E-1919
R001920	E-1920
R001921	E-1921
R001922	E-1922
R001923	E-1923
R001924	E-1924
R001925	E-1925
R001926	E-1926
R001927	E-1927
R001928	E-1928
R001929	E-1929
R001930	E-1930
R001931	E-1931
R001936	E-1936
R002091	E-2091
R002123	E-2123
R002307	E-2307

MERITOR (cont)

COMPETITOR NUMBER	EUCLID NUMBER
R002652	E-2652
R002654	E-2654
R003371	E-3371
R003372	E-3372
R003520AHD	E-3520AHD
R003863A	E-3863A
R003909	E-3909
R003910	E-3910
R003911	E-3911
R004737A	E-4737A
R004738A	E-4738A
R004739	E-4739
R004934A	E-4934A
R004935	E-4935
R005205	E-5205
R005206	E-5206
R005207	E-5207
R005208	E-5208
R005240A	E-5240A
R005241A	E-5241A
R005242A	E-5242A
R005243A	E-5243A
R005244A	E-5244A
R005476	E-5476
R005833	E-5833
R005834	E-5834
R005850	E-5850
R005851	E-5851
R005854	E-5854
R005855	E-5855
R005856	E-5856
R005901	E-6000A
R006000	E-6000A
R006038	E-6038
R006040	E-6040
R006137	E-6137
R00632	E-632
R007651	E-7651
R007653	E-7653
R00864	E-864
R008906	E-8906
R009095	E-9095A
R009136	E-9136
R009139	E-9139
R009319	E-9319
R009320	E-9320
R009575	E-9575
R00959	E-959
R009590	E-9590
R009591	E-9591
R009592	E-9592
R009593	E-9593

COMPETITOR INTERCHANGE

MERITOR (cont)		MERITOR (cont)		MERITOR (cont)	
COMPETITOR NUMBER	EUCLID NUMBER	COMPETITOR NUMBER	EUCLID NUMBER	COMPETITOR NUMBER	EUCLID NUMBER
R009594	E-9594	R307505	E-7505	R507008	E-3710HD
R009596	E-9596	R307506	E-7506	R507008	E-3710S
R009597	E-9597	R307507	E-7507	R507008BK	E-3710S
R009598	E-9598	R307508	E-7508	R507008BULK	E-3710S
R009599	E-9599	R307524	E-7524	R507010	E-3710HD
R009600	E-9600	R307525	E-7525	R507010	E-3710SHD
R009601	E-9601	R307526	E-7526	R507010BK	E-3710SHD
R009602	E-9602	R307527	E-7527	R507010BULK	E-3710SHD
R009787A	E-9787A	R307640	E-7640	R507011	E-2121
R009788A	E-9788A	R307641	E-7641	R507012	E-2121HD
R009791HD	E-9791HD	R307643	E-7643	R507014	E-2030HD
R1308E	E-5126	R307644	E-7644	R507015	E-2402HD
R301107	E-1107	R308650	E-8650	R507057	E-5481A
R301307	E-1307	R308652	E-8652	R507057BK	E-5481A
R301600	E-1600	R308656	E-8656	R507057BULK	E-5481A
R302130	E-2130	R308918	E-8918	R507061	E-8923
R302644	E-2644	R308919	E-8919	R507062	E-8925
R303975	E-3975	R308927	E-8927	R507063	E-5515
R30700	E-700	R309321	E-9321	R507064	E-10244
R307430	E-7430	R30937	E-937	R507064	E-10244S
R307431	E-7431	R309506	E-9506	R507067	E-1812
R307439	E-7439	R309507	E-9507	R507068	E-1357A
R307440	E-7440	R309575	E-9575	R507068	E-2403HD
R307445	E-7445	R401493	E-1493	R507069	E-2676
R307448	E-7448	R401495	E-1495	R507070	E-2713
R307450	E-7450	R4023969	E-1495	R507071	E-2740
R307451	E-7451	R402726	E-2726	R507072	E-2821
R307458	E-7458	R404078	E-4078	R507073	E-3291
R307459	E-7459	R4049624	E-1493	R507074	E-3373HD
R307460	E-7460	R40FC004395	E-2726	R507075	E-3374HD
R307461	E-7461	R40H1456	E-4078	R507076	E-3782
R307462	E-7462	R4311	E-1778	R507077	E-3801
R307463	E-7463	R4515	E-2778	R507078	E-5306
R307464	E-7464	R4515F3	E-3920	R507079	E-5499
R307465	E-7465	R4515F5	E-6075	R507080	E-7231
R307466	E-7466	R4515P	E-2241	R507081	E-7237
R307467	E-7467	R467390	E-7390	R507082	E-7238
R307468	E-7468	R4701	E-2778	R507083	E-9039
R307469	E-7469	R4707	E-5503	R507084	E-9048
R307470	E-7470	R4708F	E-8922	R507085	E-9052
R307471	E-7471	R4708R	E-8924	R507086	E-9141
R307472	E-7472	R4709	E-5480	R507087	E-9142
R307473	E-7473	R507000	E-2126	R507088	E-9281
R307477	E-7477	R507002	E-1887AHD	R507089	E-9282
R307482	E-7482	R507002	E-1887ASHD	R507090	E-9283
R307483	E-7483	R507002BK	E-1887ASHD	R507092	E-10756
R307484	E-7484	R507002BULK	E-1887ASHD	R507093	E-10757
R307497	E-7497	R507003	E-2820	R507094	E-10760
R307499	E-7499	R507004	E-5139	R507095	E-10875
R307502	E-7502	R507005	E-2286	R507096	E-11493
R307503	E-7503	R507006	E-4880S	R508000	E-2769S
R307504	E-7504	R507007	E-4880SHD	R508000BK	E-2769S

COMPETITOR INTERCHANGE

MERITOR (cont)		MERITOR (cont)		MERITOR (cont)	
COMPETITOR NUMBER	EUCLID NUMBER	COMPETITOR NUMBER	EUCLID NUMBER	COMPETITOR NUMBER	EUCLID NUMBER
R508000BULK	E-2769S	R517510	E-5477	R567022	E-8907
R508001	E-2769SHD	R527001	E-1581	R567023	E-752
R508001BK	E-2769SHD	R527002	E-3227	R567024	E-544
R508001BULK	E-2769SHD	R527003	E-2109	R567027	E-2804
R508002	E-6999S	R537001	E-2390	R567028	E-2805
R508002BK	E-6999S	R537003	E-1403	R567501	E-5122
R508002BULK	E-6999S	R537004	E-2773	R567502	E-1418
R508003	E-6999SHD	R537005	E-3711	R567503	E-10197
R508003BK	E-6999SHD	R537005	E-3711S	R567505	E-10198
R508003BULK	E-6999SHD	R537006	E-2029	R567507	E-10761
R508004	E-3484	R547001	E-2401	R567526	E-11980
R508014	E-3895S	R547003	E-2391	R570004	E-9047
R508014BK	E-3895S	R547004	E-2392	R570005	E-530
R508014BULK	E-3895S	R547006	E-1107	R577001	E-2389
R508015	E-3895SHD	R547007	E-1808	R577001	E-2399
R508015BK	E-3895SHD	R547008	E-1893S	R587001	E-937
R508015BULK	E-3895SHD	R547010	E-5304	R607001	E-1094
R508029	E-3869	R547011	E-5305	R607002	E-1095
R508030	E-7899	R547013	E-1813	R607003	E-1393
R508053	E-9644	R547015	E-947	R607004	E-1394
R508824	E-9064	R547019	E-2723	R607005	E-1410
R509000	E-1816HD	R547020	E-2725	R607006	E-1411
R509000	E-1816S	R547021	E-2726	R607007	E-1420
R5090001	E-1816SHD	R547022	E-2798	R607008	E-1421
R509000BK	E-1816S	R547023	E-1337	R607009	E-1422
R509000BULK	E-1816S	R547024	E-9041	R607010	E-1423
R509001	E-1816HD	R547025	E-9042	R607011	E-1563
R509001	E-1816SHD	R547028	E-9061	R607012	E-1564
R509001BK	E-1816SHD	R547029	E-714	R607015	E-1775
R509001BULK	E-1816SHD	R547030	E-608	R607016	E-1776
R509094	E-4691	R547032	E-671	R607017	E-1788
R509095	E-6879	R547033	E-1426	R607018	E-1789
R509406	E-2675HD	R557001	E-2389	R607019	E-2099
R509408	E-3992	R567001	E-2101	R607019	E-2100
R509409	E-1607HD	R567001	E-2785	R607020	E-2099
R517001	E-3421A	R567002	E-1583	R607020	E-2100
R517002	E-1582	R567003	E-1400	R607021	E-2107
R517003	E-2395	R567004	E-1402	R607021	E-2108
R517005	E-1406	R567005	E-2398	R607022	E-2107
R517005	E-2208	R567006	E-1428A	R607022	E-2108
R517006	E-2217A	R567008	E-3228	R607023	E-2492
R517006	E-595	R567009	E-5123	R607024	E-2493
R517006K	E-2217A	R567010	E-3490B	R607025	E-2693
R517010	E-1304	R567011	E-1025	R607025	E-2694
R517011	E-1305	R567011	E-2101	R607026	E-2693
R517012	E-9043	R567012	E-9037	R607026	E-2694
R517013	E-9044	R567013	E-9038	R607027	E-2714A
R517014	E-9045	R567014	E-979	R607028	E-2715A
R517016	E-2802	R567015	E-2770	R607029	E-2786
R517017	E-2803	R567016	E-980	R607030	E-2787
R517506	E-2396	R567017	E-2475	R607031	E-2794
R517509	E-596A	R567020	E-9046	R607032	E-2795

COMPETITOR INTERCHANGE

MERITOR (cont)		MERITOR (cont)		MERITOR (cont)	
COMPETITOR NUMBER	EUCLID NUMBER	COMPETITOR NUMBER	EUCLID NUMBER	COMPETITOR NUMBER	EUCLID NUMBER
R607033	E-2796	R607083	E-2412	R607122	E-9029
R607034	E-2797	R607083	E-2412A	R607123	E-9034
R607035	E-2799	R607084	E-2413	R607124	E-9035
R607036	E-2800	R607084	E-2413A	R607125	E-4888
R607037	E-3523	R607085	E-9688	R607126	E-4889
R607037	E-3524	R607085	E-9688A	R607127	E-5058
R607038	E-3523	R607086	E-9687A	R607128	E-5059
R607038	E-3524	R607086	E-9687A	R607129	E-5129
R607039	E-4712	R607087	E-9692A	R607130	E-5130
R607040	E-4713	R607087	E-9692A	R607131	E-5133
R607041	E-4716	R607088	E-9691A	R607132	E-5134
R607042	E-4717	R607088	E-9691A	R607133	E-5060
R607043	E-4718	R607089	E-4710B	R607134	E-5061
R607044	E-4719	R607090	E-4711B	R607135	E-5062
R607045	E-4720	R607091	E-2478B	R607136	E-5063
R607046	E-4721	R607092	E-2479B	R607137	E-5131
R607047	E-4722	R607093	E-4714A	R607138	E-5132
R607048	E-4723	R607093	E-4715A	R607139	E-5135
R607049	E-4740	R607094	E-4714A	R607140	E-5136
R607050	E-4741	R607094	E-4715A	R607143	E-5066
R607051	E-690	R607095	E-4706B	R607144	E-5067
R607052	E-691	R607096	E-4707B	R607147	E-9763
R607055	E-4885	R607097	E-4702B	R607148	E-9764
R607056	E-4884	R607097	E-4703B	R607149	E-9765
R607057	E-4886	R607098	E-4702B	R607150	E-9766
R607058	E-4887	R607098	E-4703B	R607151	E-9767
R607063	E-688A	R607099	E-4704B	R607152	E-9768
R607064	E-689A	R607099	E-4707B	R607153	E-9769
R607065	E-2448A	R607100	E-4705B	R607154	E-9770
R607066	E-2447A	R607101	E-689	R607155	E-9771
R607067	E-2452A	R607101	E-689A	R607156	E-9772
R607068	E-2451A	R607102	E-688	R607161	E-3862
R607069	E-2450A	R607102	E-688A	R607162	E-3861
R607070	E-2449A	R607103	E-9055	R607163	E-9761
R607071	E-1773C	R607104	E-9056	R607164	E-9762
R607072	E-1774C	R607105	E-5492	R607165	E-5096
R607073	E-4708B	R607106	E-5493	R607166	E-5097
R607074	E-4709B	R607107	E-5496	R607167	E-2793
R607075	E-1147C	R607108	E-5497	R607168	E-2792
R607075B40	E-1147C	R607109	E-5494	R607169	E-3854
R607076	E-1148C	R607110	E-5495	R607170	E-3855
R607076B40	E-1148C	R607111	E-5490	R607171	E-3856
R607077	E-2700B	R607112	E-5491	R607172	E-3857
R607078	E-2701B	R607113	E-9059	R607173	E-5516
R607079	E-9690A	R607114	E-9060	R607174	E-5517
R607079	E-9690A	R607115	E-9057	R607175	E-5518
R607080	E-9689A	R607116	E-9058	R607176	E-5519
R607080	E-9689A	R607117	E-9030	R607177	E-5520
R607081	E-1424A	R607118	E-9031	R607178	E-5521
R607081	E-556	R607119	E-9032	R607179	E-5522
R607082	E-1425A	R607120	E-9033	R607180	E-5523
R607082	E-557	R607121	E-9028	R607181	E-5524

COMPETITOR INTERCHANGE

MERITOR (cont)		MERITOR (cont)		MERITOR (cont)	
COMPETITOR NUMBER	EUCLID NUMBER	COMPETITOR NUMBER	EUCLID NUMBER	COMPETITOR NUMBER	EUCLID NUMBER
R607182	E-5525	R607234	E-9738	R607292	E-10924
R607183	E-5526	R607235	E-9739	R607293	E-10925
R607184	E-5527	R607236	E-9740	R607294	E-10926
R607185	E-6101	R607237	E-9741	R607295	E-10927
R607186	E-6102	R607238	E-9742	R607296	E-10928
R607187	E-6103	R607239	E-9743	R607297	E-10929
R607188	E-6104	R607240	E-9744	R607298	E-10930
R607189	E-6884	R607241	E-9745	R607315	E-11856
R607190	E-6885	R607242	E-9746	R607316	E-11857
R607191	E-7217	R607243	E-9747	R607317	E-11858
R607192	E-7218	R607244	E-9748	R607318	E-11859
R607193	E-7219	R607245	E-9751	R607319	E-11860
R607194	E-7220	R607246	E-9752	R607320	E-11861
R607195	E-9096	R607247	E-9753	R607321	E-11862
R607196	E-9097	R607248	E-9754	R607322	E-11863
R607197	E-9098	R607249	E-9755	R607323	E-11864
R607198	E-9099	R607250	E-9756	R607324	E-11865
R607199	E-9100	R607251	E-9757	R607325	E-11866
R607200	E-9101	R607252	E-9758	R607326	E-11867
R607201	E-9263	R607253	E-9759	R615000	E-2494
R607202	E-9264	R607254	E-9760	R615001	E-2469
R607203	E-9265	R607261	E-4886	R615001	E-2526
R607204	E-9266	R607262	E-4887	R615002	E-2125
R607205	E-9267	R607263	E-4890	R615003	E-2089
R607206	E-9268	R607264	E-4891	R615004	E-2696A
R607207	E-9269	R607265	E-9750	R615005	E-2090
R607208	E-9270	R607266	E-9749	R615006	E-2122
R607209	E-9271	R607267	E-10899	R615007	E-2680
R607210	E-9272	R607268	E-10900	R615008	E-2287
R607211	E-9273	R607269	E-10901	R615009	E-2087
R607212	E-9274	R607270	E-10902	R615010	E-2469
R607213	E-9275	R607271	E-10903	R615011	E-3353A
R607214	E-9276	R607272	E-10904	R615012	E-3354
R607215	E-9277	R607273	E-10905	R615013	E-5140
R607216	E-9278	R607274	E-10906	R615014	E-5307
R607217	E-9279	R607275	E-10907	R615015	E-5501
R607218	E-9280	R607276	E-10908	R615016	E-7235
R607219	E-9709	R607277	E-10909	R615018	E-9053
R607220	E-9710	R607278	E-10910	R615019	E-9790A
R607221	E-9725	R607279	E-10911	R615020	E-9791
R607222	E-9726	R607280	E-10912	R615021	E-10897
R607223	E-9727	R607281	E-10913	R615022	E-9791HD
R607224	E-9728	R607282	E-10914	R615023	E-11450
R607225	E-9729	R607283	E-10915	R615024	E-11450HD
R607226	E-9730	R607284	E-10916	R615025	E-11897
R607227	E-9731	R607285	E-10917	R615026	E-11981
R607228	E-9732	R607286	E-10918	R617001	E-661
R607229	E-9733	R607287	E-10919	R617001	E-759
R607230	E-9734	R607288	E-10920	R617002	E-2102
R607231	E-9735	R607289	E-10921	R617003	E-759
R607232	E-9736	R607290	E-10922	R617004	E-536
R607233	E-9737	R607291	E-10923	R617005	E-2690A

COMPETITOR INTERCHANGE

MERITOR (cont)		MERITOR (cont)		MERITOR (cont)	
COMPETITOR NUMBER	EUCLID NUMBER	COMPETITOR NUMBER	EUCLID NUMBER	COMPETITOR NUMBER	EUCLID NUMBER
R617006	E-2695	R670002	E-1215	R700030	E-10877
R617007	E-1571	R670003	E-1216	R700031	E-10878
R617008	E-2517	R670004	E-1217	R700455	E-2728
R617009	E-1577A	R670005	E-1218	R700458	E-2729
R617011	E-2732	R670006	E-1230	R700512	E-4785
R617012	E-2716	R670007	E-1493	R704311	E-1778
R617015	E-9792A	R670008	E-1495	R704317	E-1777
R627001	E-1408	R670009	E-1496	R704515	E-3920
R627002	E-1565	R670010	E-1497	R704516	E-3920
R627005	E-1782	R670011	E-2153	R704536	E-2393
R627006	E-1781	R670012	E-2154	R704536	E-2393A
R627007	E-3473	R670013	E-2155	R704551	E-3714
R627008	E-1416A	R670014	E-2156	R704552	E-3713
R627009	E-1385	R670015	E-2157	R704591	E-2394
R627011	E-719	R670016	E-2158	R704595	E-2712
R627012	E-3234	R670017	E-2159	R704605	E-1489
R627014	E-910	R670018	E-2161	R704876	E-2241
R627015	E-2405	R670019	E-2162	R780200	E-9136
R627016	E-910	R670020	E-2163	R801001	E-11395
R627017	E-1569	R670021	E-2281	R801002	E-11396
R627018	E-1416	R670022	E-2282	R801003	E-11397
R627019	E-1314	R670023	E-2552	R801040	E-6991A
R627022	E-602	R670024	E-2745	R801041	E-11398
R627023	E-961	R670025	E-2746	R801041	E-6992A
R627024	E-2404	R670027	E-1486	R801042	E-11399
R627025	E-2409	R670029	E-1217	R801042	E-6991A
R627026	E-2717	R700001	E-1398	R801043	E-6992A
R627027	E-2720	R700004	E-1580	R801044	E-6991A
R627028	E-2733	R700005	E-2393	R801045	E-6924B
R627029	E-5127	R700006	E-2393A	R801045	E-6940
R627030	E-5128	R700007	E-2394A	R801045	E-6992A
R627031	E-5137	R700008	E-2474	R801046	E-6991A
R627032	E-5138	R700009	E-2801	R801047	E-6991A
R627033	E-5482	R700010	E-2819	R801048	E-6992A
R627034	E-9789	R700011	E-5303A	R801049	E-6991A
R627039	E-2734	R700012	E-5500	R801050	E-6992A
R627043	E-10800	R700013	E-7230	R801069	E-6993A
R627044	E-10801	R700014	E-7236	R801070	E-6994A
R630002	E-2103	R700015	E-9025	R801071	E-6993A
R630003	E-2104	R700016	E-9026	R801072	E-11400
R630006	E-4586	R700017	E-9027	R801072	E-6994A
R630007	E-4587	R700018	E-9036	R801073	E-11401
R630008	E-4593	R700019	E-9040	R801073	E-6994A
R630009	E-4594	R700021	E-9054	R801074	E-11402
R630010	E-9600	R700022	E-9140	R801074	E-6993A
R630011	E-9598	R700023	E-9509	R801075	E-6993A
R630012	E-9599	R700024	E-10270	R801076	E-11403
R657001	E-807	R700025	E-10271	R801076	E-6994A
R657002	E-759	R700026	E-10273	R801077	E-6993A
R657003	E-1567	R700027	E-10762	R801078	E-6993A
R657005	E-667	R700028	E-10763	R801079	E-11404
R670001	E-1214	R700029	E-10876	R801079	E-6994A

COMPETITOR INTERCHANGE

MERITOR (cont)

MERITOR (cont)

MERITOR (cont)

COMPETITOR NUMBER	EUCLID NUMBER
R801080	E-6994A
R801081	E-6994A
R801082	E-6994A
R801083	E-6994A
R801084	E-6994A
R801085	E-6994A
R801086	E-6993A
R801087	E-6993A
R801088	E-6994A
R801100	E-6995A
R801101	E-11405
R801101	E-6996A
R801102	E-11406
R801102	E-6995A
R801700	E-11432
R802070	E-11407
R802071	E-11408
R802260	E-6991A
R802261	E-6991A
R802262	E-6991A
R802263	E-6991A
R802270	E-6991A
R802271	E-6991A
R802276	E-6991A
R802277	E-6991A
R802280	E-6923B
R802280	E-6991A
R802281	E-6923B
R802281	E-6936
R802281	E-6991A
R802290	E-6992A
R802291	E-6992A
R802292	E-6992A
R802293	E-6992A
R802300	E-6992A
R802301	E-6992A
R802302	E-6992A
R802303	E-6992A
R802310	E-6992A
R802311	E-6992A
R802312	E-6992A
R802313	E-6992A
R802314	E-6992A
R802315	E-6992A
R802316	E-11409
R802316	E-6992A
R802317	E-11410
R802317	E-6992A
R802318	E-6992A
R802319	E-6992A
R802320	E-6992A
R802321	E-6992A

COMPETITOR NUMBER	EUCLID NUMBER
R802330	E-6992A
R802331	E-6992A
R802332	E-11411
R802332	E-6992A
R802333	E-11412
R802333	E-6924B
R802333	E-6940
R802333	E-6992A
R802350	E-6991A
R802351	E-6991A
R802354	E-6991A
R802355	E-6991A
R802356	E-6923B
R802356	E-6936
R802356	E-6991A
R802357	E-6923B
R802357	E-6936
R802357	E-6991A
R802360	E-6992A
R802361	E-6992A
R802362	E-6992A
R802363	E-6992A
R802370	E-6992A
R802371	E-6992A
R802380	E-11413
R802381	E-11414
R802400	E-6993A
R802401	E-6993A
R802402	E-6993A
R802403	E-6993A
R802410	E-6993A
R802411	E-6993A
R802412	E-6993A
R802413	E-6993A
R802414	E-6993A
R802415	E-6993A
R802416	E-6925B
R802416	E-6993A
R802417	E-6942
R802417	E-6993A
R802420	E-6994A
R802421	E-6994A
R802422	E-6994A
R802423	E-6994A
R802430	E-6994A
R802431	E-6994A
R802432	E-6994A
R802433	E-6994A
R802440	E-6994A
R802441	E-6994A
R802442	E-6994A
R802443	E-6994A

COMPETITOR NUMBER	EUCLID NUMBER
R802444	E-11415
R802444	E-6927B
R802444	E-6944
R802444	E-6994A
R802445	E-11416
R802445	E-6927B
R802445	E-6944
R802445	E-6994A
R802446	E-11417
R802446	E-6994A
R802447	E-11418
R802447	E-6994A
R802448	E-6994A
R802449	E-6994A
R802450	E-6994A
R802451	E-6994A
R802452	E-6994A
R802453	E-6994A
R802462	E-11419
R802462	E-6994A
R802463	E-11420
R802463	E-6994A
R802470	E-6994A
R802471	E-6994A
R802480	E-6993A
R802481	E-6993A
R802482	E-6993A
R802483	E-6993A
R802486	E-11421
R802486	E-6993A
R802487	E-11422
R802487	E-6993A
R802488	E-6993A
R802489	E-6993A
R802490	E-11423
R802490	E-6925B
R802490	E-6942
R802490	E-6993A
R802491	E-11424
R802491	E-6925B
R802491	E-6942
R802491	E-6993A
R802492	E-6993A
R802493	E-6993A
R802500	E-6994A
R802501	E-6994A
R802502	E-6994A
R802503	E-6994A
R802504	E-6994A
R802505	E-6994A
R802510	E-6994A
R802511	E-6994A

COMPETITOR INTERCHANGE

MERITOR (cont)		MERITOR (cont)		NAVISTAR	
COMPETITOR NUMBER	EUCLID NUMBER	COMPETITOR NUMBER	EUCLID NUMBER	COMPETITOR NUMBER	EUCLID NUMBER
R802512	E-11403	R806505	E-6982	109112R1	E-4740
R802512	E-6927B	R810018	E-11428A	109113R1	E-4741
R802512	E-6944	R810019	E-11430A	109519R1	E-1148C
R802513	E-11902	R810020	E-11898	109520R1	E-1147C
R802513	E-6927B	R810021	E-11900	11040R1	E-1090
R802513	E-6940	R810022	E-11899	110540R1	E-1090
R802513	E-6994A	R810023	E-11901	110541R1	E-1089
R802610	E-6996A	R810024	E-11427A	110542R2	E-3477
R802611	E-6996A	R810025	E-11429A	122407R1	E-536
R802616	E-6995A	R810300	E-10262	126402R1	E-539
R802617	E-6995A	R810302	E-6983	126403R1	E-512
R802620	E-6995A	R810303	E-6984	126404R1	E-523
R802621	E-6995A	R810305	E-6985	131048	E-3975
R802630	E-6996A	R810308	E-6967A	13611VA	E-3427
R802631	E-6996A	R822000	E-612S-BK	138808R2	E-527
R802656	E-6992A	R822001	E-940S-BK	139856R1	E-3421A
R802657	E-6992A	R822003	E-2458S-BK	141063R1	E-512
R802666	E-11425	R822004	E-2459S-BK	142739R1	E-3445
R802666	E-6992A	R822005	E-2668	142917R1	E-2217A
R802667	E-11426	R822006	E-2669	142917R1	E-595
R802667	E-6992A	R822007	E-1574S-BK	142918R1	E-596A
R804000	E-6944	R822009	E-4904S	142919R3	E-1428A
R806001	E-6951A	R822011	E-2760	150544R1	E-4707B
R806002	E-10892	R822014	E-2763	153156R1	E-4702B
R806003	E-10893	R822019	E-4904S	153157R1	E-4708B
R806005	E-6932	R823000	E-612HD	1617829C1	E-6000A
R806006	E-6933	R823000	E-612HD	1691529C1	E-536
R806007	E-6928	R823001	E-940HD	185843R1	E-580
R806008	E-6934	R823002	E-2458HD	2001106R1	E-7643
R806009	E-6900A	R823003	E-2459HD	207184R1	E-1147C
R806010	E-6902A	R823008	E-1574HD	207184R1	E-1148C
R806011	E-6903A	R824000	E-612S-BK	207185R1	E-1147C
R806012	E-6905A	R824009	E-4904S	20966R1	E-1314
R806013	E-6942	R825009	E-9105	212085R1	E-1773C
R806014	E-6946	R825020	E-9102	212086R1	E-1774C
R806015	E-6936	R991006	E-1319A	225260R92	E-9321
R806016	E-6918A	RV31010S	10-10S	228884R1	E-3472
R806017	E-6919A	RV-3107	10-7S	239664C1	E-1137
R806018	E-6914A	RV-3108S	10-8S	258009C2	E-1128
R806019	E-6944	RV-377	7-7S	258024C1	E-5541
R806020	E-6947	RV-387	8-7S	259726C1	E-4708B
R806021	E-6940	RV-388	8-8S	264621C1	E-1458
R806022	E-6924B	RV-876	7-6S	264630C91	E-5532
R806023	E-6923B	S156	E-2522	265162C1	E-4711B
R806024	E-6925B	S265D	E-579A	266303C1	E-1140
R806025	E-6905A	S843	E-773	268439C1	E-1262
R806026	E-6927B	WA14	E-2522	270203C1	E-7644
R806500	E-6912	WA15	E-2522	295610C1	E-2476
R806501	E-6913	WA15Z	E-2522	303844C1	E-5537
R806502	E-6906A			303845C1	E-5538
R806503	E-6907A			3212934R	E-801
R806504	E-6981			327185C91	E-3995

COMPETITOR INTERCHANGE

NAVISTAR (cont)		NAVISTAR (cont)		NAVISTAR (cont)	
COMPETITOR NUMBER	EUCLID NUMBER	COMPETITOR NUMBER	EUCLID NUMBER	COMPETITOR NUMBER	EUCLID NUMBER
327187C1	E-2137	56109R1	E-543	IT271194	E-1577A
327188C1	E-2136	56110R1	E-686	IT271196	E-2695
329665C1	E-1136	56111R1	E-687	IT271197	E-2361
330855C1	E-2134	56115R1	E-581	IT271198	E-1571
330856C1	E-2135	56116R1	E-580	IT271200	E-535
340210C91	E-1261	56119R98	E-535	IT271208	E-1314
352680C91	E-654	56121R2	E-654	IT281231	E-807
358224C91	E-2140	56121R3	E-654	IT281232	E-759
361716C91	E-2141	585958C1	E-1775	IT281233	E-536
385957C1	E-1776	588992C91	E-9662	IT281234	E-667
385958C1	E-1775	588993C91	E-9661	IT281235K	E-943
385960C1	E-1418	590173C91	E-1773C	IT281237	E-1567
417488C1	E-3859	590665	E-4937	IT281243	E-2670
429284R1	E-1398	590666	E-4936	IT281252	E-2380
430394C1	E-2714A	59174C91	E-1774C	IT281253	E-1271
430395C1	E-2715A	596301C91	E-3439	IT281255	E-2291
431566C1	E-2787	62322R1	E-1880B	IT281257	E-661
431567C1	E-2786	62322R1	E-545A	IT281258	E-602
462421C1	E-4886	62333R1	E-544	IT291267	E-1272
462422C1	E-4887	67678R1	E-1781	IT291270	E-654
462424C1	E-2475	69339R1	E-526	IT291301	E-526
472697C1	E-7483	69340R1	E-603	IT291302	E-1569
472958C1	E-512	753997C93	E-7484	IT291308	E-581
472976C1	E-1428A	88119R1	E-526	IT291309	E-564
474497C9	E-2804	95373R2	E-662	IT291322	E-1565
474498C1	E-2805	966152R1	E-2701B	IT291326	E-2409
474546C1	E-2119	966153R1	E-2700B	IT301358	E-1318A
474546C1	E-502	966197R1	E-920	IT301362	E-603
478888C91	E-2290	974401R1	E-1425A	IT30A	E-2769SHD
482438C1	E-3424	97999R1	E-1782	IT311405	E-4739
487473C1	E-3437	983622R1	E-747	IT311430	E-4934A
487479C1	E-3499	987395R1	E-7482	IT321426	E-781
487480C91	E-3492	IT14A	E-1816SHD	IT321428	E-2177
491688C1	E-1140	IT15527	E-1112A	IT321430	E-1582
492283C1	E-2768	IT15542	E-2766S	IT321436	E-505
493186C1	E-3513	IT15543	E-2773	IT321441	E-595
501788C1	E-3523	IT16561	E-920	IT321441A	E-795
501789C1	E-3524	IT192A	E-1607HD	IT331476	E-886
506673C1	E-4888	IT19853	E-1880B	IT331476A	E-886
506674C1	E-4889	IT19856	E-2768	IT341525	E-801
56098R1	E-2218	IT19857	E-2101	IT341529	E-539
56098R1	E-541	IT19859	E-1418	IT341530	E-3227
56102R1	E-2111A	IT19860	E-2767	IT341531	E-1581
56102R1	E-500	IT19863	E-1583	IT341532	E-3007A
56103R1	E-501	IT19875	E-2785	IT351576	E-537
56104R1	E-502	IT2025	E-4890	IT351577	E-563
56105R1	E-579A	IT2026	E-4891	IT351580	E-1113
56106R1	E-1269	IT2029	E-2693	IT351581	E-2391
56106R1	E-1426	IT2030	E-2694	IT351582	E-1269
56106R1	E-537	IT20883	E-2109	IT437032	E-2287
56107R1	E-563	IT21929	E-1580	IT437033	E-2469
56108R1	E-538	IT2307	E-2307	IT437034	E-2086B

COMPETITOR INTERCHANGE

NAVISTAR (cont)	
COMPETITOR NUMBER	EUCLID NUMBER
IT437036	E-1357A
IT437037	E-2382
IT437038	E-2122
IT437039	E-2090
IT437044	E-2363
IT5528	E-5528
NWRA	
COMPETITOR NUMBER	EUCLID NUMBER
X2156	E-6000A
SIRCO	
COMPETITOR NUMBER	EUCLID NUMBER
333B	E-6000A
411	E-6000A
4311EHD	E-1887ASHD
4311EHD	E-4311EHD-N
45154707Q	E-2769S
45154707QHD	E-2769SHD
45154707QM	E-3895SHD
4515Q	E-4515Q-N
4515QHD	E-4515QHD-N
4515QMM	E-3895S
4515QMM	E-4515U
4515QMMHD	E-3895SHD
4515QMMHD	E-4515UHD
4515X	E-4515X
4515XHD	E-3710SHD
4515XHD	E-4515XHD
583X	E-583X
628X	E-628X
634X	E-634X
635X	E-635X
636X	E-636X
700	E-700
702	E-702A
807	E-807
8501	E-1269
9012	E-1597A
999X	E-999X
ARK	E-4800
B011	E-563
B052	E-595
B053	E-2802
B054	E-1582
B111	E-538
B120	E-2766S
B122	E-5087
B132	E-2396
B133	E-2395
B134	E-3482
B135	E-3483

SIRCO (cont)	
COMPETITOR NUMBER	EUCLID NUMBER
B151	E-539
B152	E-596A
B154	E-2803
B161	E-3007A
B161B	E-3007A
B211	E-541
B211S	E-2218
B216	E-2390
B217	E-5304
B218	E-5305
B220	E-2767
B221	E-5088
B230	E-3472
B251	E-512
B251	E-512S
B251	E-523
B256	E-757
B262	E-3424
B277	E-3711
B277	E-3711S
B302	E-2768
B307	E-2398
B308	E-3481A
B311	E-502
B347	E-9069
B348	E-9643
B349	E-3490B
B350	E-8907
B358	E-2399
B362	E-2389
B377	E-2773
B379	E-527
B380	E-2392
B392	E-2391
B423	E-747
B424	E-1403
B425	E-1406
B426	E-1402
B427	E-1400
B429	E-937
B430	E-10239
B430K	E-5477
B431	E-5478
B432A	E-10197
B433	E-9037
B434	E-10198
B436	E-9038
B495	E-920
B495	E-920S
B495S	E-920
B498	E-3227
B499	E-501

SIRCO (cont)	
COMPETITOR NUMBER	EUCLID NUMBER
B500	E-500
B501	E-1269
B501	E-1426
B556	E-3427
B562	E-5123
B579	E-3437
B586	E-586
B595	E-919
B595S	E-919
B611	E-781
B667	E-667
B669	E-5093
B707	E-3993B
B717	E-2717
B725	E-3421A
B728	E-1880B
B728	E-1880S
B769	E-1418
B770	E-2805
B793	E-801
B793A	E-9076
B794	E-9076
B795	E-2720
B800	E-10800
B801	E-10801
B805	E-9789
B806	E-11449
B807	E-807
B811	E-3473
B823	E-2723
B824	E-2724
B825	E-2725
B826	E-2726
B829	E-2724
B829	E-2725
B829	E-2726
B832	E-609
B8600	E-536
B8600A	E-536
B8600A	E-5512
B8601	E-661
B8602	E-759
B8603	E-535
B8604	E-526
B8605	E-581
B8606	E-2102
B8606A	E-9792A
B8607	E-580
B8608	E-656
B8609	E-654
B861	E-579A
B8610	E-564

COMPETITOR INTERCHANGE

SIRCO (cont)		SIRCO (cont)		SIRCO (cont)	
COMPETITOR NUMBER	EUCLID NUMBER	COMPETITOR NUMBER	EUCLID NUMBER	COMPETITOR NUMBER	EUCLID NUMBER
B8611	E-719	B8653P	E-2287	B8705A	E-2087
B8612	E-1416	B8655	E-2469	B8707	E-3993B
B8612A	E-1416A	B8655A	E-2469	B8707A	E-3993B-2
B8613	E-1272	B8655A	E-2469-2	B8708A	E-2088A
B8614	E-1271	B8655Z	E-5307	B871	E-9643
B8615	E-2380	B8655ZA	E-5307-2	B8712	E-2494
B8616	E-1385	B8656	E-2087	B8712A	E-2494
B8619	E-1565	B8656A	E-2087	B8713	E-603
B8620	E-1567	B8656A	E-2087-2	B8714	E-2104
B8621	E-1314	B8657	E-2089	B8718	E-3478
B8622	E-1569	B8657A	E-2089	B8719	E-3479
B8623	E-1571	B8660	E-2291	B872	E-3421A
B8624	E-1577A	B8660	E-2670	B8721	E-2405
B8625	E-2405	B8661	E-2291	B8722	E-3234
B8626	E-2406	B8661	E-2670	B8725	E-4594
B8627	E-2408	B8662	E-1307	B8725A	E-4594
B8628	E-2407	B8663	E-1308	B8726	E-4593
B8629	E-1782	B8665	E-2551	B8727	E-4587
B8630	E-1781	B868	E-1581	B8727	E-4593
B8631	E-2404	B8681	E-2088A	B8727A	E-4587
B8632	E-2409	B8681A	E-2088A	B8727B	E-4587
B8633	E-2411A	B8681HD	E-2088AHD	B8728	E-4586
B8634	E-910	B8681HDA	E-2088AHD-2	B8733	E-2103
B8634A	E-9077	B8682	E-2469	B8735	E-1319A
B8635	E-943	B8682	E-2526	B8736	E-2477B
B8636	E-2361	B8682A	E-2526	B8736A	E-2477B
B8643	E-1357A	B8683	E-3520A	B8740	E-2125
B8643A	E-1357A	B8683A	E-3520A	B8741	E-3993B
B8644	E-2363	B8683A	E-3520A-2	B8741A	E-3993B
B8644A	E-2363	B8683HD	E-3520AHD	B8742	E-5140
B8645	E-2382	B8683HDA	E-3520AHD-2	B8742A	E-5140-2
B8645A	E-2382	B8684	E-2696A	B8743	E-3446
B8646	E-2086B	B8684A	E-2696A	B8743A	E-3446-2
B8646A	E-2086B	B8684A	E-2696A-2	B8744	E-3876
B8646A	E-2086B-2	B8685	E-2680	B8744A	E-3876-2
B8647	E-2089	B8685A	E-2680	B8745	E-5094A
B8647	E-2123	B8685Z	E-2680	B8746	E-5501
B8647A	E-2123	B8685ZA	E-2680-2	B8746A	E-5501-2
B8648	E-2125	B8686	E-2679A	B8746Z	E-10897
B8648A	E-2125	B8686HD	E-2679AHD	B8747HD	E-3989AHD
B8648A	E-2125-2	B8688	E-2695	B8747HDA	E-3989AHD
B8649	E-2090	B8689	E-5093	B8747HDA	E-3989AHD-2
B8649A	E-2090	B869	E-1583	B8750	E-5127
B8649A	E-2090-2	B8690	E-3859	B8751	E-5128
B8650	E-2122	B8691	E-4736	B8752	E-5137
B8650A	E-2122	B8696	E-1318A	B8753	E-5138
B8650A	E-2122-2	B8696HD	E-1318AHD	B8754	E-3447
B8651	E-2087	B8697	E-1408	B8755	E-3469
B8652	E-2287	B8698	E-2690A	B8756	E-3471
B8652A	E-2287-2	B8699	E-2517	B8757	E-3476
B8653	E-2287	B870	E-2770	B8758	E-3475
B8653A	E-2469	B8702A	E-2363	B8760	E-3877

COMPETITOR INTERCHANGE

SIRCO (cont)		SIRCO (cont)		SIRCO (cont)	
COMPETITOR NUMBER	EUCLID NUMBER	COMPETITOR NUMBER	EUCLID NUMBER	COMPETITOR NUMBER	EUCLID NUMBER
B8761	E-3878	B973	E-3513	C413L	E-2413
B8762	E-5095	B974	E-543	C413L	E-2413A
B8763	E-5482	B981	E-1428A	C420R	E-1420
B8764	E-3991	B982	E-2804	C421L	E-1421
B8766	E-5513	B983	E-2475	C422R	E-1422
B8771	E-9080	B988	E-1113	C423L	E-1423
B8772M	E-9078	B999	E-5122	C424R	E-1424A
B8773M	E-9079	BB604	E-526	C425L	E-1425A
B8773MHD	E-9079HD	BK145FM	E-10866A	C426R	E-9650
B8773MHDA	E-9079HD-2	BK145R	E-10870	C427L	E-9649
B8781	E-9071	BP100	E-10818	C441L	E-2441B
B8782	E-6080	BP104	E-10814	C442R	E-2442B
B8783	E-6076	BP105	E-10812	C443L	E-2443B
B8784	E-6077	BP106	E-10826	C443R	E-2443B
B8785	E-9072	BP107	E-10834	C444R	E-2444B
B8786	E-9074	BP108	E-10836	C445L	E-2445B
B8787	E-9075	BP109	E-10838	C446R	E-2446B
B8788	E-6078	BP110	E-10835	C478R	E-2478B
B8790	E-9791	C083L	E-9681	C479L	E-2479B
B8790HD	E-9791HD	C084R	E-9682	C519R	E-5523
B8792	E-9790A	C085L	E-9677	C520L	E-5524
B8792A	E-9790A-2	C087L	E-5508	C521R	E-5525
B8793	E-9053	C089L	E-9089	C522R	E-9660
B8794	E-11450	C090R	E-9090	C524L	E-9659
B8794HD	E-11450HD	C091L	E-5506	C526L	E-5526
B8794HDA	E-11450HD-2	C092R	E-5507	C527R	E-5527
B8795	E-7235	C094R	E-1094	C536R	E-9662
B887	E-1112A	C095L	E-1095	C537L	E-9661
B888	E-1893S	C096L	E-9096	C563L	E-1563
B888D	E-8938	C097R	E-9097	C564R	E-1564
B888S	E-1893	C098L	E-9098	C594R	E-9672
B888T	E-1362	C099R	E-9099	C595L	E-9671
B898	E-2798	C100R	E-2100	C608R	E-11867
B901	E-537	C101L	E-2099	C609L	E-11866
B911	E-2177	C102L	E-9100	C645L	E-9645
B922	E-2672	C103R	E-9101	C646R	E-9646
B923	E-3511	C107L	E-2107	C647L	E-9647
B924	E-5089	C108R	E-2108	C648R	E-9648
B941	E-523	C147R	E-1147C	C651L	E-9651
B942	E-2217A	C148L	E-1148C	C652R	E-9652
B942B	E-2217S	C185L	E-9683	C653L	E-9653
B950	E-3870	C186R	E-9684	C654R	E-9654
B951	E-3871	C349L	E-9659	C655L	E-9655
B952	E-3872	C349L	E-9659	C656R	E-9656
B953	E-3869	C350R	E-9660	C657L	E-9657
B953	E-3873	C350R	E-9660	C658R	E-9658
B954	E-3874	C351L	E-9661	C663L	E-9663
B956	E-9063	C352R	E-9662	C664R	E-9664
B960	E-2411A	C410R	E-1410	C665L	E-9665
B961	E-9073	C411L	E-1411	C666R	E-9666
B971	E-545A	C412R	E-2412	C667L	E-9667
B972	E-3512	C412R	E-2412A	C668R	E-9668

COMPETITOR INTERCHANGE

SIRCO (cont)

COMPETITOR NUMBER	EUCLID NUMBER
C669L	E-9669
C670R	E-9670
C675L	E-9675
C676R	E-9676
C677L	E-9677
C678R	E-9678
C679L	E-9679
C680R	E-9680
C681L	E-9681
C682R	E-9682
C683L	E-9683
C684R	E-9684
C686R	E-686
C687L	E-687
C693L	E-2693
C694R	E-2694
C702R	E-4702B
C703L	E-4703B
C706R	E-4706B
C707L	E-4707B
C708R	E-4708B
C709L	E-4709B
C710R	E-4710B
C711L	E-4711B
C714R	E-4714
C715L	E-4715
C716R	E-4716
C717L	E-4717
C720R	E-4720
C721L	E-4721
C724L	E-9725
C725R	E-9726
C730R	E-9672
C731L	E-9671
C737L	E-9737
C738R	E-9738
C750L	E-9693
C751R	E-9694
C752L	E-9695
C753R	E-9696
C754L	E-9697
C755R	E-9698
C756L	E-9699
C757R	E-9700
C759L	E-9759
C760R	E-9760
C761L	E-9703
C762R	E-9704
C763L	E-9701
C764R	E-9702
C773R	E-1773C
C774L	E-1774C

SIRCO (cont)

COMPETITOR NUMBER	EUCLID NUMBER
C775R	E-1775
C776L	E-1776
C799R	E-2799
C800L	E-2800
C884L	E-4884
C885R	E-4885
C931L	E-9731
C932R	E-9732
C933L	E-9733
C934R	E-9734
C935L	E-9735
C936R	E-9736
C972L	E-9729
C973R	E-9730
EF1	E-1308E
EF1	E-5139
EF2	E-10760
EK1HD	E-1887AHD
EK1HD	E-1887ASHD
EK1HD	E-4311EHD-N
EK1HDS	E-1887ASHD
EK2	E-2821
EK3	E-3801
EKINT	E-1887ASHD
EKINT	E-4311EHD-N
EQ1	E-8925
ES1	E-4709ES-N
ES1	E-5481A
ES2	E-10244S
ES2	E-4709ES2-N
ES3	E-9141
ES4	E-9039
EX1	E-8923
FF1	E-7231
FF1S	E-7232
FK1	E-2121
FK1HD	E-2121HD
FR1	E-7237
FR1S	E-7238
K3	E-11318
K3	E-4709ES-N
K4	E-11319
K4	E-4709ES2-N
LB1	E-2402HD
LB10	E-10756
LB11	E-10757
LB2	E-3373HD
LB3	E-3484
LB3D	E-10875
LB4	E-2126
LB5	E-2286
LB6	E-3782

SIRCO (cont)

COMPETITOR NUMBER	EUCLID NUMBER
LB7	E-5306
LB8	E-9283
LB9	E-9281
M12WK10611	E-1420
MF1	E-9644
MF2	E-9644
MF3	E-9070
MK1	E-2675HD
MK1HD	E-2675HD
MK2	E-5086
QK1	E-2769S
QK1	E-4515Q-N
QK1A	E-6999SHD
QK1HD	E-2769SHD
QK1HD	E-4515QHD-N
QK1MPHD	E-2769HD
QK1MPHD	E-4515QHD-N
QK2	E-3895S
QK2	E-4515U
QK-2	E-6999S
QK2HD	E-3895SHD
QK2HD	E-4515UHD
QK2HD	E-6999SHD
QK2S	E-3895S
QK2S	E-4515U
QK2SHD	E-3895SHD
QK2SHD	E-4515UHD
QK8	E-6999S
QK8A	E-6999S
QK8HD	E-6999SHD
QKINT	E-2769HD
QKINT	E-4515QHD-N
RC1	E-3468A
RF1	E-4691
RF1ARK	E-1308T
RF1ARK	E-4691
RF1ARKS	E-4691
RF2ARK	E-6879
RF3	E-1308Q
RF3	E-3869
RF3A	E-1308Q
RF3A	E-7899
RF5	E-4702-KT
RF5	E-9064
RK1	E-3518
RK2	E-3992
S2001	E-9133
S2002	E-9133
S2010A	E-612S-BK
S2012A	E-1574S-BK
S2019A	E-2459S-BK
S2020A	E-940S-BK

COMPETITOR INTERCHANGE

SIRCO (cont)	
COMPETITOR NUMBER	EUCLID NUMBER
S2021A	E-612HD
S2022A	E-2458S-BK
S2023	E-5498
S2024	E-9102
S2025	E-2091
S2026	E-4904S
SA10100	E-6925B
SA10101	E-6927B
SA10102	E-6923B
SA10103	E-6924B
SA10144	E-6918A
SA10211	E-6944
SA10212	E-6942
SA10214	E-6946
SA10215	E-6940
SA10216	E-6936
SA10305	E-6933
SA10306	E-6928
SA21102	E-6992A
SA21103	E-6991A
SA21953	E-10950A
SA22102	E-6994A
SA22103	E-6993A
SA22953	E-10949A
SA23106	E-6995A
SA24100	E-6987A
SA25100	E-6989A
SA41100	E-10780A
SA41106	E-10782A
SA42100	E-10779A
SA42106	E-10781A
SA43106	E-10783A
SK1	E-5499
SR1005	E-3975
SR1011	E-937
TK4	E-1816S
TK4	E-4515P
TK4HD	E-1816SHD
TK4HD	E-4515PHD
TK4MPHD	E-1816HD
TK4MPHD	E-4515PHD
TK7	E-1607HD
TK7HD	E-1607HD
TK7HD10	E-1607HD
WF1	E-3291
XK1	E-4880S
XK1HD	E-4880SHD
XK3	E-3710S
XK3	E-4515X
XK3HD	E-3710SHD
XK3HD	E-4515XHD
XK3MPHD	E-3710HD

SIRCO (cont)	
COMPETITOR NUMBER	EUCLID NUMBER
XK3MPHD	E-4515XHD
XK3S	E-3895S
XK3S	E-4515U
XKINT	E-3710HD
XKINT	E-4515XHD
XL1	E-5515
SLOAN	
COMPETITOR NUMBER	EUCLID NUMBER
2010	E-612S-BK
2011	E-2458S-BK
2012	E-1574S-BK
2013	E-2091
2020	E-940S-BK
2021R	E-2459S-BK
2023	E-940S-BK
2029	E-2459S-BK
2031	E-2458S-BK
2045	E-2669
2046	E-2668
2066	E-2459S-BK
2089	E-940S-BK
2096	E-2458S-BK
421128	E-10158
STANDARD FORGE	
COMPETITOR NUMBER	EUCLID NUMBER
102102002	E-864
200999002	E-1108
200999010	E-957
201116001	E-2241
201118	E-2684
201130	E-2685
201132001	E-5239
201140	E-2394
201142	E-2393
201144	E-5500
202100166L	E-687
202100166R	E-686
202100175L	E-2795
202100175R	E-2794
202100185L	E-2413A
202100-185L	E-689A
202100185R	E-2412A
202100-185R	E-688A
202100-187L	E-2413A
202100-187R	E-2412A
202100205L	E-1424A
202100205L	E-1425A
202100205L	E-557
202100205R	E-1424A
202100205R	E-1425A

STANDARD FORGE (cont)	
COMPETITOR NUMBER	EUCLID NUMBER
202100205R	E-556
202100236L	E-1095
202100236R	E-1094
202100242L	E-4716
202100242R	E-4717
202100245L	E-2797
202100245R	E-2796
202103206L	E-5096
202103206L	E-5097
202103206R	E-5096
202103206R	E-5097
202103213L	E-1411
202103213LH	E-1411
202103213R	E-1410
202103213RH	E-1410
202103233L	E-1423
202103233LH	E-1423
202103233R	E-1422
202103233RH	E-1422
202103241L	E-1421
202103241LH	E-1421
202103241R	E-1420
202103241RH	E-1420
202103247L	E-2793
202103247R	E-2792
203100001	E-502
203100002	E-503
203102001	E-512
203105003	E-2029
203106	E-609
203108	E-2390
203109	E-1112A
203112001	E-2390
203113001	E-5304
203205003	E-2029
204100001	E-2176
204100001	E-500
204101001	E-2177
204101001	E-523
204102	E-5303A
204104	E-504
204105	E-586
204108001	E-2395
205100001	E-501
205107001	E-2396
206100001	E-947
207100	E-2399
207102	E-747
208102	E-1880B
208102	E-545A
208104	E-544
208105	E-1025

COMPETITOR INTERCHANGE

STANDARD FORGE (cont)

COMPETITOR NUMBER	EUCLID NUMBER
208105	E-2101
208106	E-2398
208106	E-5305
208106	E-757
209108001	E-2104
209999018	E-2104
209999019	E-2103
211102001	E-3775
211102001	E-886
212101	E-612HD
212102	E-612HD
212111	E-2091
212116	E-612HD
21404	E-910
214100	E-801
214102	E-527
214103	E-539
214106	E-538
214107	E-2392
400101	E-773
400102	E-797X
400103	E-579A
400143	E-633X
400144	E-634X
402101	E-1107
403101	E-563
403104	E-1106
403105	E-719
403107	E-564
403108	E-656
403112	E-1408
403147	E-2391
403149	E-2409
403150	E-2404
405101	E-2218
405101	E-541
405102	E-530
405106	E-667
405109	E-661
405123	E-602
405125	E-535
405126	E-536
405128	E-2102
405129	E-759
405131	E-2389
405133	E-807
408100	E-654
408101	E-1416
408103	E-654
409100	E-1269
409100	E-1426
409100	E-537

STANDARD FORGE (cont)

COMPETITOR NUMBER	EUCLID NUMBER
4500	E-1808
999195205	E-4737A
999195206	E-4738A
999197	E-2401
UB1126	E-602
UB1165	E-3775
UB1165	E-886
UB1172	E-3775
UB1172	E-886
UB2212	E-1808
UB2223L	E-1421
UB2223R	E-1420
UB2264L	E-1411
UB2264R	E-1410
UB2304	E-1813
UB2415L	E-1423
UB2415R	E-1422
UB30031	E-1813
UB3012	E-947
UB4500	E-1808
UB5102	E-3775
UB5102	E-886
TRAILMOBILE	
COMPETITOR NUMBER	EUCLID NUMBER
11516	E-747
11882	E-609
12241	E-1893
12608	E-1140
15108	E-943
15109	E-943
15174	E-1402
15193	E-937
15276	E-1112A
15305	E-2477B
15333	E-3995
15405	E-612HD
15408	E-1113
15409	E-1893
15846	E-691
15847	E-690
16101	E-1140
16857	E-937
17037	E-1094
17038	E-1095
17186	E-526
17274	E-1137
17275	E-1136
17345	E-1261
17374	E-1137
17375	E-1136
17A2366	E-1574HD

TRAILMOBILE (cont)

COMPETITOR NUMBER	EUCLID NUMBER
17A2366B	E-1574HD
19050	E-2522
19060	E-5541
19065	E-1262
19079	E-2522
19085	E-1272
19089	E-2380
19090	E-1271
19094	E-1424A
19095	E-1425A
19096	E-1319A
19116	E-545A
19118	E-656
19132	E-523
19142	E-2241
19145	E-2522
19161	E-504
19170	E-503
19171	E-781
19172	E-586
19245	E-1735
19249	E-1128
21K141	E-2696A
21K145	E-2469
21K151	E-2680
21K62	E-2030HD
21L1074	E-1410
21L1075	E-1411
21L1194	E-689
21L1194	E-689A
21L1204	E-1774C
21L1205	E-1773C
21L1299	E-2441B
21L1498	E-1893
21L1648	E-2459HD
21L1653	E-2452A
21L1654	E-2451A
21L1655	E-2450A
21L1656	E-2449A
21L2441	E-2795
21L261	E-2412
21L261	E-2412A
21L261	E-688
21L261	E-688A
21L262	E-2413
21L262	E-2413A
21L262	E-689
21L262	E-689A
21L263	E-633X
21L438	E-1108
221425001	E-3975
22T5495	E-937

COMPETITOR INTERCHANGE

TRAILMOBILE (cont)		TRAILMOBILE (cont)		TRAILMOBILE (cont)	
COMPETITOR NUMBER	EUCLID NUMBER	COMPETITOR NUMBER	EUCLID NUMBER	COMPETITOR NUMBER	EUCLID NUMBER
23197	E-1425A	381493	E-1493	382089	E-2089
23197	E-557	381563	E-1563	382090	E-2090
3-23-2	E-1107	381564	E-1564	382091	E-2091
3-23-3	E-1107	381565	E-1565	382098	E-2098
36179933	E-6000A	381567	E-1567	382099	E-2099
36-2028	0415541009	381569	E-1569	382100	E-2100
37080	E-545A	381571	E-1571	382102	E-2102
37081	E-656	381574HD	E-1574HD	382103	E-2103
37084	E-502	381577A	E-1577A	382104	E-2104
37090	E-563	381597A	E-1597A	382111A	E-2111A
37096	E-501	381600	E-1600	382119	E-2119
37338	E-1107	381773B	E-1773C	382122	E-2122
37462	E-537	381774B	E-1774C	382123	E-2123
37703	E-1107	381775	E-1775	382125	E-2125
37811	E-580	381776	E-1776	382126	E-2126
37824	E-541	381816HD	E-1816HD	382130	E-2130
37825	E-2111A	381816S	E-1816S	382153	E-2153
37825	E-500	381816SHD	E-1816SHD	382155	E-2155
37829	E-564	381880B	E-1880B	382157	E-2157
381089	E-1089	381887AHD	E-1887AHD	382177	E-2177
381090	E-1090	381887ASHD	E-1887ASHD	382193	E-2193
381094	E-1094	381901	E-1901	382217A	E-2217A
381095	E-1095	381902	E-1902	382282	E-2282
381108	E-1108	381904	E-1904	382286	E-2286
381112	E-1112A	381906	E-1906	382287	E-2287
381113	E-1113	381908	E-1908	382290	E-2290
381136	E-1136	381909	E-1909	382291	E-2291
381137	E-1137	381910	E-1910	382307	E-2307
381147B	E-1147C	381912	E-1912	382361	E-2361
381148B	E-1148C	381913	E-1913	382363	E-2363
381214	E-1214	381914	E-1914	382382	E-2382
381250	E-1250	381915	E-1915	382390	E-2390
381261	E-1261	381917	E-1917	382393A	E-2393A
381314	E-1314	381919	E-1919	382394	E-2394
381318A	E-1318A	381920	E-1920	382394A	E-2394A
381319A	E-1319A	381921	E-1921	382395	E-2395
381357	E-1357A	381922	E-1922	382396	E-2396
381362	E-1362	381923	E-1923	382398	E-2398
381385	E-1385	381924	E-1924	382399	E-2399
381408	E-1408	381925	E-1925	382402HD	E-2402HD
381410	E-1410	381926	E-1926	382403HD	E-2403HD
381411	E-1411	381927	E-1927	382405	E-2405
381416	E-1416	381932	E-1932	382407	E-2407
381416A	E-1416A	381935	E-1935	382408	E-2408
381418	E-1418	381936	E-1936	382411A	E-2411A
381420	E-1420	382015	E-2015	382412	E-2412
381421	E-1421	382029	E-2029	382412	E-2412A
381422	E-1422	382030HD	E-2030HD	382441A	E-2441B
381423	E-1423	382086B	E-2086B	382442A	E-2442B
381424	E-1424A	382087	E-2087	382443A	E-2443B
381425	E-1425A	382088A	E-2088A	382444A	E-2444B
381428A	E-1428A	382088AHD	E-2088AHD	382445A	E-2445B

COMPETITOR INTERCHANGE

TRAILMOBILE (cont)		TRAILMOBILE (cont)		TRAILMOBILE (cont)	
COMPETITOR NUMBER	EUCLID NUMBER	COMPETITOR NUMBER	EUCLID NUMBER	COMPETITOR NUMBER	EUCLID NUMBER
382446A	E-2446B	383007A	E-3007A	383993B	E-3993B
382449	E-2449A	383227	E-3227	383994	E-3994
382450	E-2450A	383228	E-3228	383995	E-3995
382451	E-2451A	383231	E-3231	384586	E-4586
382452	E-2452A	383234	E-3234	384587	E-4587
382458HD	E-2458HD	383347	E-9655	384593	E-4593
382459HD	E-2459HD	383349	E-9659	384594	E-4594
382469	E-2469	383349	E-9659	384691	E-4691
382477A	E-2477B	383350	E-9660	384702A	E-4702B
382477B	E-2477B	383350	E-9660	384703A	E-4703B
382478A	E-2478B	383351	E-9661	384704A	E-4707B
382479A	E-2479B	383352	E-9662	384705A	E-4705B
382494	E-2494	383353A	E-3353A	384708A	E-4708B
382517	E-2517	383373HD	E-3373HD	384709A	E-4709B
382526	E-2526	383379	E-3379	384715	E-4715
382644	E-2644	383421A	E-3421A	384715	E-4715A
382652	E-2652	383437	E-3437	384716	E-4716
382654	E-2654	383439	E-3439	384717	E-4717
382669	E-2669	383446	E-3446	384718	E-4718
382670	E-2670	383473	E-3473	384719	E-4719
382679A	E-2679A	383479	E-3479	384720	E-4720
382680	E-2680	383482	E-3482	384721	E-4721
382690A	E-2690A	383484	E-3484	384722	E-4722
382693	E-2693	383490B	E-3490B	384723	E-4723
382694	E-2694	383491	E-3491	384730	E-9672
382695	E-2695	383516	E-3516	384731	E-9671
382696A	E-2696A	383520A	E-3520A	384732	E-4732A
382700A	E-2700B	383523	E-3523	384733	E-4733A
382701A	E-2701B	383524	E-3524	384734	E-9676
382723	E-2723	383525	E-3525	384736	E-4736
382724	E-2724	383680	E-2680	384738A	E-4738A
382725	E-2725	383710	E-3710HD	384739	E-4739
382726	E-2726	383710HD	E-3710HD	384740	E-4740
382733	E-2733	383710S	E-3710S	384741	E-4741
382739	E-2739	383710SHD	E-3710SHD	384800	E-4800
382746	E-2746	383711	E-3711	384880S	E-4880S
382763	E-2763	383775	E-3775	384880SHD	E-4880SHD
382766	E-2766S	383782	E-3782	384884	E-4884
382767	E-2767	383854	E-3854	384885	E-4885
382768	E-2768	383855	E-3855	384886	E-4886
382769	E-2769HD	383856	E-3856	384887	E-4887
382769HD	E-2769HD	383857	E-3857	384890	E-4890
382769S	E-2769S	383861	E-3861	384891	E-4891
382769SHD	E-2769SHD	383862	E-3862	384894	E-9667
382792	E-2792	383863	E-3863A	384895	E-9668
382793	E-2793	383869	E-3869	384897	E-9650
382794	E-2794	383872	E-3872	384904	E-4904S
382795	E-2795	383873	E-3873	384995	E-4995
382796	E-2796	383895SHD	E-3895SHD	384996	E-4996
382797	E-2797	383975	E-3975	38502	E-502
382807	E-2807	383989	E-3989AHD	38512	E-512
382821	E-2821	383989AHD	E-3989AHD	385126	E-5126

COMPETITOR INTERCHANGE

TRAILMOBILE (cont)		TRAILMOBILE (cont)		TRAILMOBILE (cont)	
COMPETITOR NUMBER	EUCLID NUMBER	COMPETITOR NUMBER	EUCLID NUMBER	COMPETITOR NUMBER	EUCLID NUMBER
385139	E-5139	386080	E-6080	389096	E-9096
385140	E-5140	386081	E-5510	389097	E-9097
385205	E-5205	386082	E-5511	389098	E-9098
385206	E-5206	386101	E-6101	389099	E-9099
385207	E-5207	386102	E-6102	38912X	E-912X
38523	E-523	38612HD	E-612HD	38913X	E-913X
38526	E-526	386137	E-6137	38919	E-919
38527	E-527	38632	E-632	389265	E-9265
385303A	E-5303A	38635X	E-635X	389266	E-9266
385305	E-5305	38654	E-654	389283	E-9283
385306	E-5306	38656	E-656	38937	E-937
385307	E-5307	38661	E-661	38940HD	E-940HD
38535	E-535	38667	E-667	38943	E-943
38536	E-536	38684	E-684	38957	E-957
38539	E-539	38685	E-685	38959	E-959
38545A	E-545A	386879	E-6879	39286	E-2177
385478	E-5478	386884	E-6884	39286	E-523
385481	E-5481A	386885	E-6885	39647	E-539
385498	E-5498	386902A	E-6902A	40727	E-1139
385504	E-5504A	386905A	E-6905A	40733	E-581
385505	E-5505A	386906A	E-6906A	42922	E-536
385510	E-5510	386907A	E-6907A	42929	E-603
385511	E-5511	386914A	E-6914A	43287	E-535
385518	E-5518	386918A	E-6918A	44750	E-543
385519	E-5519	386928	E-6928	46946	E-512
385522	E-5522	386933	E-6933	50BZF23C	E-1107
385523	E-5523	386936	E-6936	7001621	E-920
385524	E-5524	386942	E-6942	7001622	E-919
385525	E-5525	386946	E-6946	70017236	E-1424A
385527	E-5527	38719	E-719	70017237	E-1425A
385528	E-5528	387212A	E-7212A	70017238	E-684
385529	E-5529	387213A	E-7213A	70017239	E-685
385530	E-5530	387214A	E-7214A	70017242	E-1094
385541	E-5541	387217	E-7217	70017243	E-1095
385543	E-5543	387218	E-7218	70017244	E-1147C
38579A	E-579A	387219	E-7219	70017245	E-1148C
38580	E-580	387220	E-7220	70017246	E-1563
38581	E-581	387232	E-7232	70017247	E-1564
385834	E-5834	387237	E-7237	70017258	E-1112A
385850	E-5850	38747	E-747	70017259	E-2769S
385854	E-5854	38752	E-752	70017290	E-1816S
385855	E-5855	387527	E-7527	70017307	E-4880S
385856	E-5856	38759	E-759	70017332	E-2100
38586	E-586	38781	E-781	70017333	E-2099
38595	E-595	387899	E-7899	700660	E-1269
38596A	E-596A	38795	E-795	7007107	E-937
386000	E-6000A	38801	E-801	7007121	E-1565
38602	E-602	38807	E-807	7007140	E-2766S
38603	E-603	38886	E-886	7007141	E-2767
386038	E-6038	389036	E-9036	7007142	E-2768
386076	E-6076	389091	E-5506	7007144	E-2411A
386078	E-6078	389092	E-5507	7007147	E-3007A

COMPETITOR INTERCHANGE

TRAILMOBILE (cont)		TRAILMOBILE (cont)		TRAILMOBILE (cont)	
COMPETITOR NUMBER	EUCLID NUMBER	COMPETITOR NUMBER	EUCLID NUMBER	COMPETITOR NUMBER	EUCLID NUMBER
7007159	E-609	7007260	E-3710SHD	70077	E-2088A
7007169	E-2090	7007261	E-1887ASHD	70077	E-2088AHD
7007171	E-4723	700727	E-541	700772	E-1569
7007172	E-4722	7007272	E-5507	700773	E-654
7007174	E-3471	7007273	E-5506	70078	E-2122
7007175	E-4721	7007274	E-5511	70079	E-2382
7007176	E-4720	7007275	E-5510	700794	E-564
7007178	E-2405	700728	E-801	700795	E-1880B
7007180	E-910	7007282	E-5526	700795	E-3490B
7007181	E-2695	7007283	E-5527	700796	E-656
7007183	E-1428A	7007286	E-9079HD	700797	E-595
7007187	E-2693	7007287	E-11910	700798	E-596A
7007188	E-2694	7007289	E-9100	700799	E-1428A
700719	E-539	700729	E-1113	700816	E-1597A
7007190	E-3227	7007290	E-9101	70099206	E-702A
7007191	E-2773	7007291	E-9761	7-12-1	E-502
7007192	E-1314	7007292	E-9762	7-12-28	E-512
7007195	E-2696A	7007293	E-5524	7-12-31	E-747
7007196	E-3710SHD	7007294	E-5525	7-12-32	E-609
7007197	E-1893	7007295	E-9733	7-13-17	E-603
7007198	E-3711	7007296	E-9734	7-18-1	E-563
7007199	E-2769SHD	7007297	E-9735	7-18-8	E-539
700720	E-523	7007298	E-9736	7-22-3	E-541
7007201	E-1816SHD	700730	E-1095	7-23-3	E-2111A
7007202	E-4880SHD	700731	E-1094	7-23-3	E-500
7007203	E-2121	700732	E-536	7-23-7	E-2177
7007205	E-2690A	700733	E-2291	7-23-7	E-523
7007206	E-2177	700734	E-943	7-24-1	E-501
7007207	E-3007A	700735	E-535	7-25-2	E-537
7007209	E-3520A	700736	E-603	7-27-3	E-564
700721	E-545A	700737	E-2361	7-3-11	E-1139
7007214	E-2122	700738	E-526	7333	E-538
7007218	E-4593	700739	E-1416	7334	E-526
7007218	E-4594	70074	E-1887ASHD	7342	E-773
7007219	E-4594	700740	E-581	7344	E-773
700722	E-747	700741	E-580	7-5-105	E-9090
7007224	E-4880S	700746	E-500	7-5-106	E-9089
7007225	E-3490B	700747	E-544	75107	E-2442B
7007226	E-6000A	700749	E-1140	75108	E-2441B
7007227	E-1318A	700751	E-1418	75111	E-2444B
700723	E-957	700753	E-512	75112	E-2443B
7007235	E-2769S	700756	E-537	75113	E-2446B
7007237	E-1887ASHD	700758	E-563	75114	E-2445B
7007238	E-3710S	70076	E-2086B	7-5-63	E-1425A
7007239	E-2769SHD	700760	E-1269	7-5-63	E-557
700725	E-502	700761	E-2670	7564L	E-1425A
7007255	E-2769S	700762	E-1567	7564L	E-557
7007256	E-2769SHD	700764	E-1571	7564R	E-1424A
7007257	E-6999SHD	700765	E-661	7564R	E-556
7007258	E-1816S	700766	E-1318A	7-6-17	E-536
7007259	E-3710S	700767	E-2102	7-6-18	E-535
700726	E-920	700768	E-1577A	7-6-33	E-1893

COMPETITOR INTERCHANGE

TRAILMOBILE (cont)	
COMPETITOR NUMBER	EUCLID NUMBER
7781	E-579A
7-8-1	E-545A
7-8-22	E-543
7-8-34	E-1140
7-9-1	E-656
7-9-11	E-581
7-9-3	E-580
7A13	E-957
7A251	E-886
7A3108	E-2685
7A3109	E-5239
7A3123	E-2241
7A3127	E-2778
7A3128	E-1778
7A3130	E-3522
7A3132	E-3920
7A395	E-2241
7A396	E-2684
CB21102	E-6992A
CB21103	E-6991A
CB22102	E-6994A
CB22103	E-6993A
CB23102	E-6996A
CB23106	E-6995A
RWKIT8000	E-2769S
RWKIT9000	E-1816HD

TRAMEC	
COMPETITOR NUMBER	EUCLID NUMBER
52010	E-612S-BK
52010	E-612HD
52011R	E-2760
52012R	E-2763
52016L	E-2669
52016R	E-2668
52017	E-2091
52028	E-2458HD
52110	E-612HD
52128	E-2458S-BK
52128	E-2458HD
52128	E-612HD
52210	E-940HD
52228	E-2459S-BK
52228	E-2459HD
52310	E-2091
52328	E-2458S-BK
52328	E-2458HD
52337	E-1574HD
52411	E-4904S
54002R	E-684
54003L	E-685
54004R	E-1094

TRAMEC (cont)	
COMPETITOR NUMBER	EUCLID NUMBER
54005L	E-1095
54006R	E-1424A
54007L	E-1425A
54008R	E-688
54008R	E-688A
54009L	E-689
54009L	E-689A
54010R	E-2794
54011L	E-2795
54012R	E-2796
54013L	E-2797
54014L	E-2441B
54015R	E-2442B
54016L	E-2443B
54017R	E-2444B
54018L	E-2445B
54019R	E-2446B
54020L	E-1563
54021R	E-1564
54022L	E-2099
54023R	E-2100
54024L	E-1789
54024R	E-1788
54025L	E-1789
54026R	E-686
54027L	E-687
54028R	E-690
54029L	E-691
54030R	E-1393
54031L	E-1394
54032R	E-1410
54033L	E-1411
54034R	E-1420
54035L	E-1421
54036R	E-1422
54037L	E-1423
54038R	E-2494
54039L	E-2493
54040R	E-1147C
54041L	E-1148C
54042R	E-1773C
54043L	E-1774C
54044R	E-1775
54045L	E-1776
54046R	E-2478B
54047L	E-2479B
54048R	E-2799
54049L	E-2800
54050R	E-2450A
54051L	E-2449A
54052R	E-2694
54053L	E-2693

TRAMEC (cont)	
COMPETITOR NUMBER	EUCLID NUMBER
54056R	E-2448A
54057L	E-2447A
54058R	E-2452A
54059L	E-2451A
54060L	E-9659
54060L	E-9659
54061R	E-9660
54061R	E-9660
54062L	E-9661
54063R	E-9662
54064L	E-9657
54065R	E-9658
54068R	E-2792
54069L	E-2793
54070L	E-3516
54071R	E-3517
54088R	E-2700B
54089L	E-2701B
54092R	E-2786
54093L	E-2787
54094L	E-3524
54094R	E-3523
59000	E-702A

WAGNER	
COMPETITOR NUMBER	EUCLID NUMBER
31944	E-2715A
31945	E-2714A
4595	E-2712
80414	E-2798
80433	E-3421A
911002	E-2121
911004	E-2675HD
911005	E-2769S
911007	E-2769SHD
911008	E-1607HD
911010	E-1887ASHD
911011	E-1887AHD
911012	E-2820
911015	E-3710S
911016	E-3710SHD
911017	E-4880S
911018	E-4880SHD
911019	E-1816S
911020	E-1816SHD
911030	E-5139
911031	E-4691
911032	E-3869
914000	E-2177
914001	E-2215
914002	E-3914
914003	E-523

COMPETITOR INTERCHANGE

WAGNER (cont)

COMPETITOR NUMBER	EUCLID NUMBER
FE80429	E-2729
FE83177	E-2728
FE88633	E-2729

COMPETITOR NUMBER	EUCLID NUMBER
----------------------	------------------

COMPETITOR NUMBER	EUCLID NUMBER
----------------------	------------------

NUMERICAL PARTS LISTING

Part No.	Page	Part No.	Page	Part No.	Page	Part No.	Page
4-4.5B.....	1-153	E-541.....	1-138	E-910.....	1-262	E-1318A.....	1-237
4-4B.....	1-153	E-543.....	1-146	E-911X.....	1-152	E-1318AHD.....	1-237
4-5B.....	1-153	E-544.....	1-144	E-912X.....	1-152	E-1319A.....	1-235
4-6B.....	1-153	E-545A.....	1-144	E-913X.....	1-152	E-1337.....	1-124
4-7B.....	1-153	E-556.....	1-179, E-195	E-914X.....	1-152	E-1357A.....	1-221
5-4B.....	1-153	E-557.....	1-179, E-195	E-915X.....	1-152	E-1362.....	2-2
5-5B.....	1-153	E-563.....	1-129	E-916X.....	1-152	E-1385.....	1-245
5-6B.....	1-153	E-564.....	1-255	E-917X.....	1-152	E-1393.....	1-179, 1-199
5-12B.....	1-153	E-579A.....	1-135	E-918X.....	1-152	E-1394.....	1-179, 1-199
7-4B.....	1-153	E-580.....	1-256	E-919.....	1-140	E-1398.....	1-156
7-5B.....	1-153	E-581.....	1-255	E-920.....	1-140	E-1400.....	1-141
7-6B.....	1-153	E-583X.....	1-152	E-920S.....	1-140	E-1402.....	1-141
7-6S.....	1-153	E-586.....	1-118	E-937.....	1-133	E-1403.....	1-127
7-7B.....	1-153	E-595.....	1-120	E-940HD.....	1-265	E-1406.....	1-117
7-7S.....	1-153	E-596A.....	1-122	E-940S-BK.....	1-265	E-1408.....	1-259
7-8B.....	1-153	E-602.....	1-244	E-943.....	1-242	E-1410.....	1-180, 1-204
7-9B.....	1-153	E-603.....	1-236	E-947.....	1-123	E-1411.....	1-180, 1-204
7-10B.....	1-153	E-608.....	1-127	E-957.....	1-163	E-1416.....	1-250
7-12B.....	1-153	E-609.....	1-124	E-959.....	1-163	E-1416A.....	1-251
7-16B.....	1-153	E-612HD.....	1-264	E-961.....	1-241	E-1418.....	1-149
8-6B.....	1-153	E-612S-BK.....	1-264	E-979.....	1-143	E-1420.....	1-182, 1-204
8-6S.....	1-153	E-628X.....	1-152	E-980.....	1-143	E-1421.....	1-182, 1-204
8-7B.....	1-153	E-632.....	1-163	E-998X.....	1-152	E-1422.....	1-181, 1-204
8-7S.....	1-153	E-633X.....	1-152	E-999X.....	1-152	E-1423.....	1-181, 1-204
8-8B.....	1-153	E-634X.....	1-152	E-1025.....	1-141	E-1424A.....	1-180, 1-196
8-8S.....	1-153	E-635X.....	1-152	E-1089.....	1-172, 1-187	E-1425A.....	1-180, 1-196
8-9B.....	1-153	E-636X.....	1-152	E-1090.....	1-172, 1-187	E-1426.....	1-129
8-9S.....	1-153	E-654.....	1-252	E-1094.....	1-181, 1-196	E-1428A.....	1-147
8-10B.....	1-153	E-656.....	1-260	E-1095.....	1-181, 1-196	E-1428S.....	1-147
8-10S.....	1-153	E-661.....	1-244	E-1106.....	1-128	E-1457.....	1-157, 1-304
8-12B.....	1-153	E-662.....	1-241	E-1107.....	1-132	E-1458.....	1-148, 1-305
10-7S.....	1-153	E-667.....	1-243	E-1108.....	1-163	E-1486.....	1-296
10-8B.....	1-153	E-671.....	1-128	E-1112A.....	1-125	E-1489.....	1-157
10-8S.....	1-153	E-684.....	1-180, 1-198	E-1113.....	1-137	E-1493.....	1-299
10-9B.....	1-153	E-685.....	1-180, 1-198	E-1115.....	1-264	E-1495.....	1-299
10-9S.....	1-153	E-686.....	1-177, 1-197	E-1116.....	1-264	E-1496.....	1-299
10-10B.....	1-153	E-687.....	1-177, 1-197	E-1128.....	1-306	E-1497.....	1-148, 1-299
10-10S.....	1-153	E-688.....	1-179, 1-197	E-1136.....	1-302	E-1563.....	1-178, 1-201
10-12B.....	1-153	E-688A.....	1-179, 1-189	E-1137.....	1-302	E-1564.....	1-178, 1-201
20-8B.....	1-153	E-689.....	1-179, 1-197	E-1139.....	1-157, 1-304	E-1565.....	1-257
20-8S.....	1-153	E-689A.....	1-179, 1-189	E-1140.....	1-149, 1-305	E-1567.....	1-247
20-9B.....	1-153	E-690.....	1-181, 1-196	E-1147C.....	1-175, 1-189	E-1569.....	1-262
20-9S.....	1-153	E-691.....	1-181, 1-196	E-1148C.....	1-175, 1-189	E-1571.....	1-246
20-10B.....	1-153	E-700.....	3-1	E-1214.....	1-298	E-1574HD.....	1-265
E-427K.....	1-274	E-702A.....	3-1	E-1215.....	1-300	E-1574S-BK.....	1-265
E-452A.....	1-274	E-702A-KA.....	3-1	E-1216.....	1-300	E-1577A.....	1-246
E-500.....	1-120	E-712.....	1-242	E-1217.....	1-300	E-1580.....	1-156
E-501.....	1-122	E-714.....	1-123	E-1218.....	1-299	E-1581.....	1-133
E-502.....	1-126	E-719.....	1-257	E-1230.....	1-298	E-1582.....	1-117
E-503.....	1-127	E-747.....	1-151	E-1250.....	2-2	E-1583.....	1-142
E-504.....	1-121	E-752.....	1-142	E-1261.....	1-304	E-1597A.....	2-4, 2-5, 2-6
E-505.....	1-121	E-757.....	1-141, 1-142	E-1262.....	1-306	E-1600.....	2-11
E-512.....	1-125	E-759.....	1-244	E-1269.....	1-130	E-1607HD.....	1-108
E-512S.....	1-126	E-773.....	1-135	E-1271.....	1-242	E-1735.....	1-306
E-523.....	1-117	E-781.....	1-117	E-1272.....	1-250	E-1773C.....	1-175, 1-189
E-526.....	1-262	E-795.....	1-120	E-1304.....	1-121	E-1774C.....	1-175, 1-189
E-527.....	1-130	E-796.....	1-120	E-1305.....	1-122	E-1775.....	1-175, 1-188
E-530.....	1-138	E-797X.....	1-152	E-1307.....	1-139	E-1776.....	1-175, 1-188
E-535.....	1-246	E-798X.....	1-152	E-1308.....	1-139	E-1777.....	1-159
E-536.....	1-243	E-801.....	1-131, 1-261	E-1308E.....	1-80	E-1778.....	1-159
E-537.....	1-129	E-807.....	1-244	E-1308Q.....	1-82	E-1781.....	1-254
E-538.....	1-131	E-864.....	1-163	E-1308QMA.....	1-82	E-1782.....	1-254
E-539.....	1-134	E-886.....	1-165	E-1314.....	1-251	E-1788.....	1-174, 1-197

NUMERICAL PARTS LISTING

Part No.	Page	Part No.	Page	Part No.	Page	Part No.	Page
E-1789	1-174, 1-197	E-2090-2	1-224	E-2380	1-247	E-2654	2-1, 2-12
E-1808	1-137	E-2091	1-265	E-2382	1-226	E-2655	2-8
E-1812	1-79	E-2098	2-2	E-2389	1-139	E-2656	2-1
E-1813	1-127	E-2099	1-180, 1-201	E-2390	1-125	E-2670	1-249
E-1816HD	1-113	E-2100	1-180, 1-201	E-2391	1-137	E-2672	1-118
E-1816S	1-111	E-2101	1-142	E-2392	1-130	E-2675HD	1-106
E-1816SHD	1-112	E-2102	1-245	E-2393	1-157	E-2676	1-104
E-1880B	1-145, 1-148	E-2103	1-235	E-2393A	1-156	E-2679A	1-226
E-1880S	1-145	E-2104	1-235	E-2394	1-157	E-2679AHD	1-227
E-1887AHD	1-90	E-2107	1-179, 1-196	E-2394A	1-156	E-2680	1-227
E-1887ASHD	1-91	E-2108	1-179, 1-196	E-2395	1-119	E-2680-2	1-227
E-1893	1-139	E-2109	1-151	E-2396	1-122	E-2684	1-161
E-1893S	1-139	E-2111A	1-119	E-2398	1-142	E-2685	1-160
E-1894	1-296	E-2119	1-126	E-2399	1-151	E-2686	1-161
E-1901	2-4, 2-5	E-2121	1-93	E-2401	1-132	E-2687	1-161
E-1902	2-4, 2-5	E-2121HD	1-94	E-2402HD	1-78	E-2689	1-157, 1-304
E-1903	2-4, 2-5	E-2122	1-224	E-2403HD	1-73	E-2690A	1-247
E-1904	2-4, 2-5	E-2122-2	1-225	E-2404	1-259	E-2693	1-179, 1-199
E-1905	2-4, 2-5	E-2123	1-225	E-2405	1-253	E-2694	1-179, 1-199
E-1906	2-4, 2-5	E-2125	1-215	E-2406	1-252	E-2695	1-246
E-1907	2-4, 2-5	E-2125-2	1-216	E-2407	1-248	E-2696A	1-227
E-1908	2-4, 2-5	E-2126	1-74	E-2408	1-247	E-2696A-2	1-228
E-1909	2-4, 2-5	E-2130	2-11	E-2409	1-256	E-2700B	1-174, 1-189
E-1910	2-4, 2-5	E-2134	1-302	E-2411A	1-256	E-2701B	1-174, 1-189
E-1911	2-4, 2-5	E-2135	1-302	E-2412	1-179, 1-198	E-2712	1-159
E-1912	2-4, 2-5	E-2136	1-302	E-2412A	1-179, 1-189	E-2713	1-86
E-1913	2-4, 2-5	E-2137	1-302	E-2413	1-179, 1-198	E-2714A	1-176, 1-190
E-1914	2-4, 2-5	E-2138	1-302	E-2413A	1-179, 1-189	E-2715A	1-176, 1-190
E-1915	2-4, 2-5	E-2139	1-302	E-2441B	1-178, 1-203	E-2716	1-242
E-1916	2-4, 2-5	E-2140	1-304	E-2442B	1-178, 1-203	E-2717	1-251
E-1917	2-4, 2-5	E-2141	1-304	E-2443B	1-180, 1-203	E-2720	1-261
E-1918	2-4, 2-5	E-2142	1-304	E-2444B	1-180, 1-203	E-2723	1-131
E-1919	2-4, 2-5	E-2153	1-298	E-2445B	1-182, 1-203	E-2724	1-136
E-1920	2-4, 2-5	E-2154	1-298	E-2446B	1-182, 1-203	E-2725	1-135
E-1921	2-4, 2-5	E-2155	1-298	E-2447A	1-178, 1-203	E-2726	1-136
E-1922	2-4, 2-5	E-2156	1-298	E-2448A	1-178, 1-203	E-2728	1-159
E-1923	2-4, 2-5	E-2157	1-299	E-2449A	1-180, 1-203	E-2729	1-159
E-1924	2-4, 2-5	E-2158	1-299	E-2450A	1-180, 1-203	E-2732	1-241
E-1925	2-4, 2-5	E-2159	1-299	E-2451A	1-182, 1-203	E-2733	1-253
E-1926	2-4, 2-5	E-2161	1-296	E-2452A	1-182, 1-203	E-2734	1-260
E-1927	2-4, 2-5	E-2162	1-296	E-2458HD	1-265	E-2735A	1-166
E-1928	2-4, 2-5	E-2163	1-149, 1-297	E-2458S-BK	1-265	E-2739	2-2
E-1929	2-4, 2-5	E-2164	1-296	E-2459HD	1-265	E-2740	1-84
E-1930	2-4, 2-5	E-2176	1-119	E-2459S-BK	1-265	E-2745	1-149, 1-297
E-1931	2-4, 2-5	E-2177	1-116	E-2469	1-211	E-2746	1-300
E-1932	2-4, 2-5	E-2193	1-306	E-2469-2	1-211	E-2766S	1-123
E-1933	2-4, 2-5	E-2208	1-116	E-2474	1-159	E-2767	1-150
E-1934	2-4, 2-5	E-2214	1-119	E-2475	1-147	E-2768	1-141
E-1935	2-4, 2-5	E-2215	1-116	E-2476	1-149, 1-305	E-2769HD	1-101
E-1936	2-4, 2-5	E-2217A	1-119	E-2477B	1-235	E-2769S	1-102
E-1937	2-4, 2-5	E-2217S	1-119	E-2478B	1-173, 1-189	E-2769SHD	1-103
E-2015	1-300, 1-306	E-2218	1-138	E-2479B	1-173, 1-189	E-2770	1-143
E-2029	1-127	E-2241	1-161	E-2484	1-301	E-2773	1-124
E-2030HD	1-78	E-2281	1-296	E-2492	1-181, 1-199	E-2778	1-162
E-2086B	1-219	E-2282	1-296	E-2493	1-181, 1-199	E-2785	1-147
E-2086B-2	1-220	E-2286	1-74	E-2494	1-212	E-2786	1-176, 1-188
E-2087	1-222	E-2287	1-225	E-2517	1-245	E-2787	1-176, 1-188
E-2087-2	1-222	E-2287-2	1-225	E-2522	1-305	E-2792	1-182, 1-204
E-2088A	1-222	E-2290	1-306	E-2526	1-212	E-2793	1-182, 1-204
E-2088AHD	1-222	E-2291	1-249	E-2551	1-241	E-2794	1-178, 1-197
E-2088AHD-2	1-223	E-2307	1-266	E-2552	1-329	E-2795	1-178, 1-197
E-2089	1-224	E-2361	1-245	E-2644	2-6, 2-11	E-2796	1-182, 1-198
E-2090	1-224	E-2363	1-226	E-2652	2-11	E-2797	1-182, 1-198

NUMERICAL PARTS LISTING

Part No.	Page	Part No.	Page	Part No.	Page	Part No.	Page
E-2798	1-129	E-3512	1-147	E-4311EHD-N	1-92	E-4891	1-180, 1-201
E-2799	1-173, 1-188	E-3513	1-151	E-4515P	1-113	E-4892	1-172, 1-197
E-2800	1-173, 1-188	E-3516	1-180, 1-202	E-4515PHD	1-115	E-4893	1-172, 1-197
E-2801	1-162	E-3517	1-180, 1-202	E-4515QHD-N	1-100	E-4900	1-180, 1-202
E-2802	1-121	E-3518	1-115	E-4515QMBHD-N	1-101	E-4901	1-180, 1-202
E-2803	1-123	E-3520A	1-228	E-4515QMB-N	1-100	E-4902	1-162
E-2804	1-148	E-3520A-2	1-228	E-4515Q-N	1-99	E-4904S	1-264
E-2805	1-150	E-3520AHD	1-229	E-4515U	1-110	E-4910A	1-177, 1-193
E-2807	1-166	E-3520AHD-2	1-229	E-4515UHD	1-110	E-4911A	1-177, 1-193
E-2819	1-159	E-3522	1-161	E-4515X	1-97	E-4912	1-172, 1-185
E-2820	1-91	E-3523	1-177, 1-188	E-4515XHD	1-98	E-4913	1-172, 1-185
E-2821	1-114	E-3524	1-177, 1-188	E-4586	1-238	E-4916	1-172, 1-185
E-3007A	1-133	E-3525	1-306	E-4587	1-238	E-4917	1-172, 1-185
E-3227	1-134	E-3710HD	1-95	E-4593	1-238	E-4918	1-173, 1-185
E-3228	1-145	E-3710S	1-96	E-4594	1-238	E-4919	1-173, 1-185
E-3231	1-119	E-3710SHD	1-97	E-4691	1-84	E-4934A	1-239
E-3234	1-260	E-3711	1-124	E-4692	1-86	E-4935	1-240
E-3291	1-85	E-3711S	1-124	E-4702B	1-175, 1-189	E-4936	1-174, 1-185
E-3303	1-161	E-3713	1-160	E-4702-KT	1-81	E-4937	1-174, 1-185
E-3304	1-161	E-3714	1-160	E-4703B	1-175, 1-189	E-4961A	1-132
E-3353A	1-217	E-3775	1-166	E-4704B	1-172, 1-189	E-4991	1-173, 1-187
E-3354	1-217	E-3782	1-77	E-4705B	1-172, 1-189	E-4992	1-173, 1-187
E-3371	2-4, 2-5	E-3801	1-92	E-4706B	1-172, 1-189	E-4993	1-173, 1-187
E-3372	2-4, 2-5	E-3823	1-161	E-4707B	1-172, 1-189	E-4994	1-173, 1-187
E-3373HD	1-76	E-3854	1-180, 1-208	E-4708B	1-176, 1-189	E-4995	1-173, 1-187
E-3374HD	1-73	E-3855	1-180, 1-208	E-4709ES2-N	1-89	E-4996	1-173, 1-187
E-3379	2-2	E-3856	1-181, 1-208	E-4709ES-N	1-87	E-5056	1-172, 1-190
E-3417	1-161	E-3857	1-181, 1-208	E-4709B	1-176, 1-189	E-5057	1-172, 1-190
E-3421A	1-118	E-3859	1-253	E-4710B	1-177, 1-189	E-5058	1-173, 1-185
E-3424	1-128	E-3861	1-182, 1-201	E-4711B	1-177, 1-189	E-5059	1-173, 1-185
E-3427	1-137	E-3862	1-182, 1-201	E-4712	1-178, 1-197	E-5060	1-173, 1-184
E-3437	1-143	E-3863A	2-1	E-4713	1-178, 1-197	E-5061	1-173, 1-184
E-3438	1-158	E-3869	1-82	E-4714	1-179, 1-197	E-5062	1-175, 1-184
E-3439	1-158	E-3870	1-128	E-4714A	1-179, 1-190	E-5063	1-175, 1-184
E-3441	1-159	E-3871	1-132	E-4715	1-179, 1-198	E-5066	1-173, 1-184
E-3445	1-128	E-3872	1-143	E-4715A	1-179, 1-189	E-5067	1-173, 1-184
E-3446	1-217	E-3873	1-150	E-4716	1-182, 1-198	E-5086	1-105
E-3446-2	1-2198	E-3874	1-136	E-4717	1-182, 1-198	E-5087	1-123
E-3447	1-241	E-3876	1-218	E-4718	1-182, 1-198	E-5088	1-150
E-3460	1-172, 1-185	E-3876-2	1-218	E-4719	1-182, 1-198	E-5089	1-118
E-3461	1-172, 1-185	E-3877	1-241	E-4720	1-181, 1-199	E-5092	1-161
E-3468A	1-216	E-3878	1-250	E-4721	1-181, 1-199	E-5093	1-261
E-3469	1-250	E-3895S	1-109	E-4722	1-179, 1-200	E-5094A	1-230
E-3471	1-258	E-3895SHD	1-109	E-4723	1-179, 1-200	E-5095	1-253
E-3472	1-258	E-3909	2-7	E-4732A	1-176, 1-192	E-5096	1-180, 1-204
E-3473	1-258	E-3910	2-7	E-4733A	1-176, 1-192	E-5097	1-180, 1-204
E-3474	1-253	E-3911	2-7	E-4736	1-261	E-5122	1-149
E-3475	1-257	E-3914	1-116	E-4737A	1-239	E-5123	1-142
E-3476	1-257	E-3920	1-160	E-4738A	1-239	E-5124	1-134
E-3477	1-258	E-3975	1-136	E-4739	1-240	E-5125	1-134
E-3478	1-258	E-3989AHD	1-229	E-4740	1-176, 1-188	E-5126	1-158
E-3479	1-257	E-3989AHD-2	1-230	E-4741	1-176, 1-188	E-5127	1-241
E-3481A	1-142	E-3991	1-252	E-4785	1-159	E-5128	1-250
E-3482	1-122	E-3992	1-114	E-4800	1-83	E-5129	1-172
E-3483	1-120	E-3993B	1-214	E-4880S	1-94	E-5130	1-172
E-3484	1-75	E-3993B-2	1-215	E-4880SHD	1-95	E-5131	1-173, 1-184
E-3490B	1-146	E-3994	1-303	E-4884	1-181, 1-198	E-5132	1-173, 1-184
E-3490S	1-146	E-3995	1-303	E-4885	1-181, 1-198	E-5133	1-174, 1-184
E-3491	1-156	E-3996	1-301	E-4886	1-174	E-5134	1-174, 1-184
E-3492	1-301	E-3997	1-301	E-4887	1-174	E-5135	1-174, 1-184
E-3495	1-157, 1-304	E-3998	1-301	E-4888	1-176, 1-188	E-5136	1-174, 1-184
E-3499	1-301	E-3999	1-301	E-4889	1-176, 1-188	E-5137	1-255
E-3511	1-117	E-4078	1-135	E-4890	1-180, 1-201	E-5138	1-255

NUMERICAL PARTS LISTING

Part No.	Page	Part No.	Page	Part No.	Page	Part No.	Page
E-5139	1-81	E-5530	1-173, 1-186	E-6918A	1-271	E-8906	1-240
E-5140	1-218	E-5531	1-301	E-6919A	1-271	E-8907	1-146
E-5140-2	1-219	E-5532	1-303	E-6923B	1-271	E-8922	1-160
E-5205	2-10	E-5538	1-302	E-6924B	1-271	E-8923	1-92
E-5206	2-10	E-5539	1-303	E-6925B	1-271	E-8924	1-160
E-5207	2-10	E-5540	1-303	E-6927B	1-271	E-8925	1-93
E-5208	2-10	E-5541	1-303	E-6928	1-271	E-8927	3-1
E-5239	1-161	E-5542	1-307	E-6932	1-272	E-8938	1-139
E-5240A	1-239	E-5543	1-307	E-6933	1-271	E-9025	1-156
E-5241A	1-239	E-5544	1-308	E-6934	1-272	E-9026	1-156
E-5242A	1-239	E-5545	1-308	E-6936	1-272	E-9027	1-158
E-5243A	1-239	E-5833	2-9	E-6940	1-272	E-9028	1-172, 1-184
E-5244A	1-239	E-5834	2-9	E-6942	1-272	E-9029	1-172, 1-184
E-5303A	1-158	E-5850	2-8	E-6944	1-272	E-9030	1-173, 1-184
E-5304	1-123	E-5851	2-8	E-6946	1-272	E-9031	1-173, 1-184
E-5305	1-150	E-5854	2-8	E-6947	1-272	E-9032	1-174, 1-184
E-5306	1-77	E-5855	2-8	E-6951A	1-270, 1-271	E-9033	1-174, 1-184
E-5307	1-212	E-5856	2-8	E-6956	1-275	E-9034	1-174, 1-184
E-5307-2	1-213	E-5857	2-9	E-6966A	1-275	E-9035	1-174, 1-184
E-5476	1-238	E-5859	2-9	E-6967A	1-275	E-9036	1-158
E-5477	1-116	E-6038	2-8	E-6981	1-270	E-9037	1-142
E-5478	1-134	E-6039	2-14	E-6982	1-270	E-9038	1-143
E-5480	1-160	E-6040	2-14	E-6983	1-275	E-9039	1-86
E-5481A	1-88	E-6041	2-15	E-6984	1-275	E-9040	1-160
E-5482	1-258	E-6061	2-3	E-6985	1-274	E-9041	1-126
E-5490	1-173, 1-188	E-6064	2-12	E-6987A	1-293	E-9042	1-135
E-5491	1-173, 1-188	E-6065	2-12	E-6988A	1-293	E-9043	1-121
E-5492	1-175, 1-188	E-6066	2-12	E-6989A	1-293	E-9044	1-121
E-5493	1-175, 1-188	E-6067	2-12	E-6990A	1-293	E-9045	1-134
E-5494	1-179, 1-200	E-6068	2-12	E-6991A	1-293	E-9046	1-144
E-5495	1-179, 1-200	E-6069	2-12	E-6992A	1-293	E-9047	1-138
E-5496	1-182, 1-200	E-6070	2-13	E-6993A	1-293	E-9048	1-88
E-5497	1-182, 1-200	E-6071	2-13	E-6994A	1-293	E-9052	1-88
E-5499	1-115	E-6072	2-13	E-6995A	1-293	E-9053	1-231
E-5500	1-162	E-6073	2-13	E-6996A	1-293	E-9054	1-160
E-5501	1-215	E-6074	2-13	E-6999S	1-103	E-9055	1-177, 1-188
E-5501-2	1-215	E-6075	1-162	E-6999SHD	1-104	E-9056	1-177, 1-188
E-5503	1-162	E-6076	1-248	E-7043	1-153	E-9057	1-179, 1-200
E-5504A	1-174, 1-191	E-6077	1-259	E-7044	1-153	E-9058	1-179, 1-200
E-5505A	1-174, 1-191	E-6078	1-231	E-7211	1-305	E-9059	1-182, 1-200
E-5506	1-178, 1-203	E-6080	1-247	E-7212A	1-307	E-9060	1-182, 1-200
E-5507	1-178, 1-203	E-6101	1-181, 1-209	E-7213A	1-307	E-9061	1-124
E-5508	1-180, 1-203	E-6102	1-181, 1-209	E-7214A	1-308	E-9062	1-158
E-5509	1-180, 1-203	E-6103	1-182, 1-209	E-7217	1-182, 1-208	E-9063	1-143
E-5510	1-182, 1-203	E-6104	1-182, 1-209	E-7218	1-182, 1-208	E-9064	1-81
E-5511	1-182, 1-203	E-6109	1-265	E-7219	1-182, 1-208	E-9065	1-173, 1-187
E-5512	1-242	E-6110	1-265	E-7220	1-182, 1-208	E-9066	1-173, 1-187
E-5513	1-230	E-6113	1-265	E-7230	1-159	E-9067A	1-174, 1-187
E-5515	1-108	E-6137	2-4, 2-5	E-7231	1-85	E-9068A	1-174, 1-187
E-5516	1-178, 1-209	E-6879	1-83	E-7232	1-85	E-9069	1-146
E-5517	1-178, 1-209	E-6884	1-181, 1-208	E-7235	1-219	E-9070	1-107
E-5518	1-179, 1-209	E-6885	1-181, 1-208	E-7236	1-159	E-9071	1-258
E-5519	1-179, 1-209	E-6900A	1-270	E-7237	1-87	E-9072	1-257
E-5520	1-181, 1-209	E-6902A	1-270	E-7238	1-87	E-9073	1-260
E-5521	1-181, 1-209	E-6903A	1-270	E-7360	1-153	E-9074	1-256
E-5522	1-178, 1-209	E-6905A	1-270	E-7450	3-1	E-9075	1-259
E-5523	1-178, 1-209	E-6906A	1-270	E-7451	3-1	E-9076	1-260
E-5524	1-180, 1-209	E-6907A	1-270	E-7651	2-4	E-9077	1-263
E-5525	1-180, 1-209	E-6910	1-270	E-7652	2-4	E-9078	1-232
E-5526	1-181, 1-209	E-6911	1-270	E-7653	2-4	E-9078HD	1-232
E-5527	1-181, 1-209	E-6912	1-270	E-7654	2-4	E-9078HD-2	1-232
E-5528	1-158	E-6913	1-270	E-7899	1-83	E-9079	1-233
E-5529	1-173, 1-186	E-6914A	1-271	E-8652	3-1	E-9079HD	1-233

NUMERICAL PARTS LISTING

Part No.	Page	Part No.	Page	Part No.	Page	Part No.	Page
E-9079HD-2	1-233	E-9597	1-239	E-9702	1-174, 1-185	E-9784	1-248
E-9080	1-234	E-9598	1-239	E-9707	1-173, 1-186	E-9785A	1-236
E-9087	1-181, 1-202	E-9599	1-239	E-9708	1-173, 1-186	E-9786A	1-236
E-9088	1-181, 1-202	E-9600	1-239	E-9709	1-177, 1-208	E-9787A	1-236
E-9089	1-181, 1-198	E-9601	1-239	E-9710	1-177, 1-208	E-9788A	1-236
E-9090	1-181, 1-198	E-9602	1-239	E-9711	1-174, 1-186	E-9789	1-247
E-9095A	1-164	E-9643	1-146	E-9712	1-174, 1-186	E-9790A	1-213
E-9095AHD	1-164	E-9644	1-108	E-9713	1-172, 1-186	E-9790A-2	1-234
E-9096	1-178, 1-209	E-9645	1-172, 1-191	E-9714	1-172, 1-186	E-9791	1-234
E-9097	1-178, 1-209	E-9646	1-172, 1-191	E-9715	1-174, 1-186	E-9791HD	1-234
E-9098	1-182, 1-209	E-9647	1-172, 1-191	E-9716	1-174, 1-186	E-9792A	1-245
E-9099	1-182, 1-209	E-9648	1-172, 1-191	E-9717	1-174, 1-186	E-9793	2-14
E-9100	1-183, 1-209	E-9649	1-173, 1-191	E-9718	1-174, 1-186	E-9868	3-2
E-9101	1-183, 1-209	E-9650	1-173, 1-191	E-9725	1-178, 1-208	E-9868W	3-2
E-9102	1-264	E-9651	1-173, 1-191	E-9726	1-178, 1-208	E-10092A	1-295
E-9103	1-264	E-9652	1-173, 1-191	E-9727	1-183, 1-209	E-10093A	1-295
E-9104	1-264	E-9653	1-174, 1-191	E-9728	1-183, 1-209	E-10094A	1-295
E-9105	1-265	E-9654	1-174, 1-191	E-9729	1-183, 1-209	E-10095A	1-295
E-9106	1-265	E-9655	1-174, 1-191	E-9730	1-183, 1-209	E-10096A	1-295
E-9132	1-296	E-9656	1-174, 1-191	E-9731	1-177, 1-210	E-10097	1-299
E-9133	1-296	E-9657	1-175, 1-192	E-9732	1-177, 1-210	E-10097G	1-299
E-9135	1-296	E-9658	1-175, 1-192	E-9733	1-180, 1-210	E-10098	1-299
E-9136	2-2	E-9659	1-175, 1-192	E-9734	1-180, 1-210	E-10098G	1-299
E-9139	2-2	E-9660	1-175, 1-192	E-9735	1-181, 1-210	E-10158	3-2
E-9140	1-158	E-9661	1-175, 1-192	E-9736	1-181, 1-210	E-10197	1-147
E-9141	1-86	E-9662	1-175, 1-192	E-9737	1-183, 1-210	E-10198	1-150
E-9142	1-99	E-9663	1-175, 1-192	E-9738	1-183, 1-210	E-10239	1-117
E-9263	1-178, 1-205	E-9664	1-175, 1-192	E-9739	1-179, 1-209	E-10243	1-164
E-9264	1-178, 1-205	E-9665	1-176, 1-192	E-9740	1-179, 1-209	E-10244	1-89
E-9265	1-179, 1-205	E-9666	1-176, 1-192	E-9741	1-182, 1-209	E-10244S	1-89
E-9266	1-179, 1-205	E-9667	1-176, 1-192	E-9742	1-182, 1-209	E-10262	1-274
E-9267	1-180, 1-205	E-9668	1-176, 1-192	E-9743	1-179, 1-204	E-10270	1-160
E-9268	1-180, 1-205	E-9669	1-176, 1-192	E-9744	1-179, 1-204	E-10271	1-160
E-9269	1-180, 1-205	E-9670	1-176, 1-192	E-9745	1-180, 1-204	E-10272	1-160
E-9270	1-180, 1-205	E-9671	1-176, 1-192	E-9746	1-180, 1-204	E-10273	1-160
E-9271	1-180, 1-205	E-9672	1-176, 1-192	E-9747	1-182, 1-204	E-10306A	1-177, 1-193
E-9272	1-180, 1-205	E-9673A	1-176, 1-192	E-9748	1-182, 1-204	E-10307A	1-177, 1-193
E-9273	1-181, 1-205	E-9674A	1-176, 1-192	E-9749	1-179, 1-205	E-10756	1-75
E-9274	1-181, 1-205	E-9675	1-177, 1-193	E-9750	1-179, 1-205	E-10757	1-76
E-9275	1-181, 1-205	E-9676	1-177, 1-193	E-9751	1-178, 1-205	E-10760	1-90
E-9276	1-181, 1-205	E-9677	1-177, 1-193	E-9752	1-178, 1-205	E-10762	1-156
E-9277	1-182, 1-205	E-9678	1-177, 1-193	E-9753	1-180, 1-206	E-10763	1-156
E-9278	1-182, 1-205	E-9679	1-177, 1-193	E-9754	1-180, 1-206	E-10776	1-260
E-9279	1-182, 1-205	E-9680	1-177, 1-193	E-9755	1-180, 1-206	E-10779A	1-294
E-9280	1-182, 1-205	E-9681	1-177, 1-193	E-9756	1-180, 1-206	E-10780A	1-294
E-9281	1-76	E-9682	1-177, 1-193	E-9757	1-181, 1-206	E-10781A	1-294
E-9282	1-73	E-9683	1-177, 1-193	E-9758	1-181, 1-206	E-10782A	1-294
E-9283	1-77	E-9684	1-177, 1-193	E-9759	1-181, 1-206	E-10783A	1-294
E-9319	2-2	E-9687A	1-173, 1-189	E-9760	1-181, 1-206	E-10784A	1-294
E-9320	2-2	E-9688A	1-173, 1-189	E-9761	1-178, 1-201	E-10785A	1-294
E-9433	2-14	E-9689A	1-176, 1-189	E-9762	1-178, 1-201	E-10786A	1-294
E-9434	2-15	E-9690A	1-176, 1-189	E-9763	1-174, 1-188	E-10787A	1-294
E-9435	2-14	E-9691A	1-177, 1-189	E-9764	1-174, 1-188	E-10788A	1-294
E-9436	2-6	E-9692A	1-177, 1-189	E-9765	1-175, 1-188	E-10789A	1-294
E-9509	1-159	E-9693	1-172, 1-185	E-9766	1-175, 1-188	E-10800	1-257
E-9569	3-1	E-9694	1-172, 1-185	E-9767	1-175, 1-188	E-10801	1-259
E-9575	2-11	E-9695	1-172, 1-185	E-9768	1-175, 1-188	E-10802	1-157
E-9590	1-239	E-9696	1-172, 1-185	E-9769	1-176, 1-188	E-10803	1-157
E-9591	1-239	E-9697	1-173, 1-185	E-9770	1-176, 1-188	E-10804	1-157
E-9592	1-239	E-9698	1-173, 1-185	E-9771	1-177, 1-188	E-10805	1-157
E-9593	1-239	E-9699	1-173, 1-185	E-9772	1-177, 1-188	E-10809	1-157
E-9594	1-239	E-9700	1-173, 1-185	E-9780	1-161	E-10810	1-157
E-9596	1-239	E-9701	1-174, 1-185	E-9783	1-248	E-10811	1-152



NUMERICAL PARTS LISTING

Part No.	Page	Part No.	Page	Part No.	Page	Part No.	Page
E-10812	1-117	E-10887-BK	1-295	E-11319	1-89	E-11523	1-173, 1-187
E-10813	1-138	E-10888-BK	1-295	E-11395	1-268	E-11524	1-173, 1-191
E-10814	1-127	E-10889-BK	1-295	E-11396	1-268	E-11525	1-173, 1-191
E-10816	1-136	E-10890-BK	1-295	E-11397	1-268	E-11526	1-174, 1-191
E-10817	1-136	E-10891	1-295	E-11398	1-268	E-11527	1-174, 1-191
E-10818	1-142	E-10892	1-271	E-11399	1-268	E-11528	1-174, 1-191
E-10819	1-132	E-10893	1-271	E-11400	1-268	E-11529	1-174, 1-191
E-10820	1-127	E-10894	1-274	E-11401	1-268	E-11530	1-174, 1-191
E-10822	1-151	E-10895	1-172, 1-190	E-11402	1-268	E-11531	1-174, 1-191
E-10823	1-118	E-10896	1-172, 1-190	E-11403	1-268	E-11532	1-174, 1-191
E-10824	1-118	E-10897	1-214	E-11404	1-268	E-11533	1-174, 1-191
E-10825	1-127	E-10899	1-175, 1-195	E-11405	1-268	E-11534	1-174, 1-191
E-10826	1-142	E-10900	1-175, 1-195	E-11406	1-268	E-11535	1-174, 1-191
E-10828	1-140	E-10901	1-180, 1-207	E-11407	1-268	E-11536	1-174, 1-191
E-10829	1-132	E-10902	1-180, 1-207	E-11408	1-268	E-11537	1-174, 1-191
E-10831	1-137	E-10903	1-180, 1-207	E-11409	1-268	E-11538	1-174, 1-187
E-10832	1-137	E-10904	1-180, 1-207	E-11410	1-268	E-11539	1-174, 1-187
E-10833	1-137	E-10905	1-181, 1-207	E-11411	1-268	E-11540	1-175, 1-191
E-10834	1-131	E-10906	1-181, 1-207	E-11412	1-268	E-11541	1-175, 1-191
E-10835	1-127	E-10907	1-182, 1-207	E-11413	1-268	E-11542	1-175, 1-191
E-10836	1-140	E-10908	1-182, 1-207	E-11414	1-268	E-11543	1-175, 1-191
E-10838	1-118	E-10909	1-182, 1-210	E-11415	1-268	E-11544	1-175, 1-192
E-10839	1-138	E-10910	1-182, 1-210	E-11416	1-268	E-11545	1-175, 1-192
E-10841-AA	1-80	E-10911	1-176, 1-188	E-11417	1-268	E-11546	1-175, 1-192
E-10842	1-137	E-10912	1-176, 1-188	E-11418	1-268	E-11547	1-175, 1-192
E-10843	1-259	E-10913	1-177, 1-188	E-11419	1-268	E-11548	1-175, 1-187
E-10844	1-162	E-10914	1-177, 1-188	E-11420	1-268	E-11549	1-175, 1-187
E-10845	1-255	E-10915	1-177, 1-188	E-11421	1-268	E-11550	1-175, 1-187
E-10846	1-213	E-10916	1-177, 1-188	E-11422	1-268	E-11551	1-175, 1-187
E-10847	1-162	E-10917	1-178, 1-194	E-11423	1-268	E-11552	1-175, 1-192
E-10848	1-252	E-10918	1-178, 1-194	E-11424	1-268	E-11553	1-175, 1-192
E-10849	1-253	E-10919	1-179, 1-194	E-11425	1-268	E-11554	1-176, 1-192
E-10850	1-162	E-10920	1-179, 1-194	E-11426	1-268	E-11555	1-176, 1-192
E-10851	1-253	E-10921	1-180, 1-194	E-11427A	1-269	E-11556	1-176, 1-192
E-10854	1-162	E-10922	1-180, 1-194	E-11428A	1-269	E-11557	1-176, 1-192
E-10857	1-259	E-10923	1-181, 1-194	E-11429A	1-269	E-11558	1-176, 1-192
E-10859	1-172, 1-190	E-10924	1-181, 1-194	E-11430A	1-269	E-11559	1-176, 1-192
E-10860	1-172, 1-190	E-10925	1-181, 1-194	E-11432	1-269	E-11562	1-176, 1-192
E-10861	1-172, 1-190	E-10926	1-181, 1-194	E-11445	1-235	E-11563	1-176, 1-192
E-10862	1-172, 1-190	E-10927	1-182, 1-194	E-11446	1-235	E-11564	1-176, 1-192
E-10863	1-172, 1-190	E-10928	1-182, 1-194	E-11449	1-244	E-11565	1-176, 1-192
E-10864	1-172, 1-190	E-10929	1-183, 1-194	E-11450	1-220	E-11566	1-176, 1-187
E-10865	1-136	E-10930	1-183, 1-194	E-11450HD	1-220	E-11567	1-176, 1-187
E-10866-AA	1-80	E-10931	1-239	E-11450HD-2	1-220	E-11568	1-176, 1-193
E-10867	1-79	E-10932	1-239	E-11451	1-250	E-11569	1-176, 1-193
E-10868	1-213	E-10933	1-239	E-11453	1-158	E-11570	1-177, 1-193
E-10869	1-79	E-10934	1-239	E-11454	1-158	E-11571	1-177, 1-193
E-10870	1-79	E-10936	1-239	E-11455	1-158	E-11572	1-177, 1-193
E-10871	1-214	E-10937	1-239	E-11456	1-158	E-11573	1-177, 1-193
E-10872	1-214	E-10939	1-239	E-11493	1-85	E-11574	1-177, 1-193
E-10875	1-74	E-10940	1-239	E-11497	1-239	E-11575	1-177, 1-193
E-10876	1-156	E-10942	1-239	E-11512	1-172, 1-191	E-11576	1-177, 1-193
E-10877	1-156	E-10943	1-239	E-11513	1-172, 1-191	E-11577	1-177, 1-193
E-10878	1-156	E-10944	1-239	E-11514	1-172, 1-191	E-11578	1-178, 1-194
E-10879-BK	1-295	E-10945	1-239	E-11515	1-172, 1-191	E-11579	1-177, 1-193
E-10880-BK	1-295	E-10946	1-240	E-11516	1-172, 1-191	E-11580	1-177, 1-193
E-10881-BK	1-295	E-10947	1-240	E-11517	1-172, 1-191	E-11581	1-177, 1-193
E-10882-BK	1-295	E-10949A	1-293	E-11518	1-172, 1-191	E-11582	1-177, 1-193
E-10883-BK	1-295	E-10950A	1-293	E-11519	1-172, 1-191	E-11583	1-177, 1-193
E-10884-BK	1-295	E-10952	1-299	E-11520	1-172, 1-187	E-11584	1-179, 1-194
E-10885	1-295	E-11003	2-7	E-11521	1-172, 1-187	E-11585	1-179, 1-194
E-10886	1-295	E-11318	1-87	E-11522	1-173, 1-187	E-11586	1-178, 1-193

NUMERICAL PARTS LISTING

Part No.	Page	Part No.	Page	Part No.	Page	Part No.	Page
E-11587	1-178, 1-193	E-11873	1-294	E-15014	1-290	E-15073	1-291
E-11588	1-178, 1-193	E-11875	1-294	E-15015	1-289	E-15074	1-291
E-11589	1-178, 1-193	E-11877	1-294	E-15016	1-288, 1-289	E-15075	1-291
E-11590	1-178, 1-193	E-11879	1-294	E-15017	1-289	E-15076	1-291
E-11591	1-178, 1-193	E-11880	1-294	E-15018	1-289	E-15077	1-291
E-11592	1-178, 1-193	E-11881	1-294	E-15019	1-288	E-15078	1-291
E-11593	1-178, 1-193	E-11882	1-294	E-15020	1-288	E-15079	1-291
E-11594	1-178, 1-193	E-11883	1-294	E-15021	1-288	E-15080	1-291
E-11595	1-178, 1-193	E-11884	1-294	E-15022	1-288	E-15081	1-291
E-11596	1-178, 1-194	E-11885	1-294	E-15023	1-289	E-15082	1-291
E-11597	1-178, 1-194	E-11890	1-294	E-15024	1-288, 1-289	E-15083	1-291
E-11598	1-179, 1-194	E-11897	1-221	E-15025	1-289	E-824100	3-3
E-11599	1-179, 1-194	E-11898	1-269	E-15026	1-289	E-824101	3-3
E-11600	1-179, 1-194	E-11899	1-269	E-15027	1-290	E-824102	3-3
E-11601	1-179, 1-194	E-11900	1-269	E-15028	1-290	E-824104	3-3
E-11602	1-179, 1-194	E-11901	1-269	E-15029	1-290	E-824105	3-3
E-11603	1-179, 1-194	E-11902	1-268	E-15030	1-290	E-824106	3-3
E-11604	1-179, 1-194	E-11904	1-216	E-15031	1-290	KIT-4HD	1-106
E-11605	1-179, 1-194	E-11907	1-168	E-15032	1-290	KIT-4S	1-106
E-11608	1-173, 1-191	E-11910	1-211	E-15033	1-290	KIT-4SHD	1-107
E-11609	1-173, 1-191	E-11921	1-273	E-15034	1-290	KIT-5	1-98
E-11610	1-173, 1-191	E-11922	1-273	E-15035	1-290	R806000	1-278
E-11611	1-173, 1-191	E-11923	1-273	E-15036	1-288	R806001	1-276
E-11612	1-174, 1-191	E-11924	1-273	E-15037	1-288	R806002	1-276
E-11613	1-174, 1-191	E-11925	1-273	E-15038	1-288	R806003	1-276
E-11618	1-175, 1-192	E-11926	1-273	E-15039	1-288	R806004	1-276
E-11619	1-175, 1-192	E-11934	1-167	E-15040	1-289	R806005	1-278
E-11622	1-175, 1-192	E-11935	1-167	E-15041	1-289	R806006	1-278
E-11623	1-176, 1-193	E-11936	1-167	E-15042	1-290	R806007	1-278
E-11624	1-176, 1-192	E-11937	1-167	E-15043	1-290	R806008	1-278
E-11625	1-176, 1-192	E-11938	1-168	E-15044	1-290	R806009	1-277
E-11626	1-176, 1-192	E-11939	1-166	E-15045	1-290	R806010	1-277
E-11627	1-176, 1-192	E-11940	1-168	E-15046	1-290	R806011	1-277
E-11628	1-176, 1-192	E-11941	1-166	E-15047	1-290	R806012	1-277
E-11629	1-176, 1-192	E-11942	1-166	E-15048	1-290	R806013	1-278
E-11630	1-176, 1-192	E-11943	1-166	E-15049	1-290	R806014	1-278
E-11631	1-176, 1-192	E-11951	1-242	E-15050	1-290	R806015	1-278
E-11632	1-177, 1-193	E-11952	1-248	E-15051	1-289	R806016	1-276
E-11633	1-177, 1-193	E-11958	1-181, 1-202	E-15051	1-289	R806017	1-276
E-11638	1-177, 1-193	E-11959	1-181, 1-202	E-15051	1-290	R806018	1-276
E-11639	1-177, 1-193	E-11968	1-173, 1-187	E-15052	1-289	R806019	1-278
E-11640	1-178, 1-193	E-11969	1-173, 1-187	E-15052	1-290	R806020	1-278
E-11641	1-178, 1-193	E-11974	1-105	E-15053	1-288	R806021	1-278
E-11642	1-179, 1-194	E-11977	1-221	E-15054	1-288	R806022	1-276
E-11643	1-179, 1-194	E-11980	1-143	E-15055	1-288, 1-289,	R806023	1-276
E-11644	1-180, 1-194	E-11981	1-80		1-290	R806024	1-276
E-11645	1-180, 1-194	E-11982	1-159	E-15056	1-289, 1-290	R806025	1-277
E-11741	1-117	E-14539	1-75	E-15057	1-289, 1-290	R806026	1-276
E-11747	1-84	E-14657	1-150	E-15058	1-289, 1-290	R806500	1-277
E-11819	1-221	E-15000	1-289	E-15059	1-289, 1-290	R806501	1-277
E-11856	1-181, 1-210	E-15001	1-288, 1-289	E-15060	1-289, 1-290	R806502	1-277
E-11857	1-181, 1-210	E-15002	1-289	E-15061	1-291	R806503	1-277
E-11858	1-181, 1-210	E-15003	1-289	E-15062	1-291	R806504	1-277
E-11859	1-181, 1-210	E-15004	1-288	E-15063	1-291	R806505	1-277
E-11860	1-182, 1-210	E-15005	1-288	E-15064	1-291	R806507	1-278
E-11861	1-182, 1-210	E-15006	1-288	E-15065	1-291	R806508	1-278
E-11862	1-183, 1-210	E-15007	1-288	E-15066	1-291	R806521	1-281
E-11863	1-183, 1-210	E-15008	1-289	E-15067	1-291	R806522	1-281
E-11864	1-175, 1-195	E-15009	1-288, 1-289	E-15068	1-291	R806523	1-281
E-11865	1-175, 1-195	E-15010	1-289	E-15069	1-291	R806524	1-281
E-11866	1-175, 1-195	E-15011	1-289	E-15070	1-291	R806525	1-280
E-11867	1-175, 1-195	E-15012	1-290	E-15071	1-291	R806526	1-280
E-11872	1-294	E-15013	1-290	E-15072	1-291	R806527	1-279

NUMERICAL PARTS LISTING

Part No.	Page	Part No.	Page	Part No.	Page	Part No.	Page
R806528	1-280						
R806529	1-280						
R806530	1-281						
R806531	1-281						
R806532	1-280						
R806533	1-280						
R806534	1-281						
R806535	1-279						
R806536	1-279						
R806537	1-280						
R806538	1-280						
R806539	1-281						
R806540	1-281						
R806541	1-280						
R806542	1-281						
R806543	1-279						
R806544	1-280						
R806545	1-280						
R806546	1-281						
R806547	1-281						
R806548	1-279						
R806549	1-279						
R806550	1-281						
R806551	1-279						
R806552	1-280						
R806553	1-281						
R806554	1-280						
R806555	1-280						
R806556	1-279						
R806557	1-281						
R806558	1-281						
R806559	1-279						
R806560	1-279						
R806563	1-281						
R806564	1-281						
R810300	1-286						
R810301	1-284						
R810302	1-283						
R810303	1-284						
R810304	1-285						
R810305	1-285						
R810306	1-285						
R810307	1-284						
R810308	1-285						
R810309	1-286						
R810310	1-284						
R810311	1-284						
R810312	1-286						
R810313	1-285						
R810314	1-284						
R810315	1-286						
R810316	1-283						
R810317	1-282						
R810318	1-283						
R810319	1-282						
R810320	1-283						
R810321	1-282						
R810322	1-282						
R810323	1-282						
R810324	1-283						
R810325	1-282						
R810326	1-282						
R810327	1-283						

EUCLID AFTERMARKET PARTS WARRANTY

We warrant all new parts for one year from date of shipment to the buyer against defective material or workmanship (but not against damage caused by accident, abuse or improper installation, maintenance or repair) when such parts are used on vehicles the specifications of which have been approved by our Engineering Department.

As the exclusive remedy under this warranty, we will, at our option, repair or replace such parts free of charge, or take back the nonconforming parts and refund the monies paid by buyer for such parts, if found on examination by us to be nonconforming and if any necessary return charges are prepaid.

If it is necessary to return any parts under this warranty, buyer agrees not to make any deduction on account thereof from remittances on current accounts while claims are in the process of disposition. Any expense incurred without our consent for repairs or replacement will not be allowed.

THIS WARRANTY IS EXPRESSLY IN LIEU OF ALL OTHER WARRANTIES OR CONDITIONS, EXPRESS, IMPLIED OR STATUTORY, INCLUDING ANY IMPLIED WARRANTY OF MERCHANTABILITY OR FITNESS FOR PARTICULAR PURPOSE. IN NO EVENT SHALL SELLER BE LIABLE FOR INCIDENTAL OR CONSEQUENTIAL DAMAGES OF ANY NATURE.

Only genuine replacement parts are covered by this aftermarket parts warranty.



Meritor Heavy Vehicle Systems, LLC

7975 Dixie Highway
Florence, KY 41042 USA
USA 888-725-9355
Canada 800-387-3889

meritor.com
XpresswayPlus.com

Distributed by:

Information contained in this publication was in effect at the time the publication was approved for printing and is subject to change without notice or liability. Meritor reserves the right to revise the information presented or discontinue the production of parts at any time.

Litho in USA
Revised 4-12
100AB
©2012 Meritor, Inc.